

**SUZUKI**

***VZR1800***

**SERVICE MANUAL**



99500-39290-01E

## FOREWORD

This manual contains an introductory description on the SUZUKI VZR1800 and procedures for its inspection/service and overhaul of its main components.

Other information considered as generally known is not included.

Read the GENERAL INFORMATION section to familiarize yourself with the motorcycle and its maintenance. Use this section as well as other sections to use as a guide for proper inspection and service. This manual will help you know the motorcycle better so that you can assure your customers of fast and reliable service.

\* This manual has been prepared on the basis of the latest specifications at the time of publication. If modifications have been made since then, differences may exist between the content of this manual and the actual motorcycle.

\* Illustrations in this manual are used to show the basic principles of operation and work procedures. They may not represent the actual motorcycle exactly in detail.

\* This manual is written for persons who have enough knowledge, skills and tools, including special tools, for servicing SUZUKI motorcycles. If you do not have the proper knowledge and tools, ask your authorized SUZUKI motorcycle dealer to help you.

### **▲ WARNING**

Inexperienced mechanics or mechanics without the proper tools and equipment may not be able to properly perform the services described in this manual. Improper repair may result in injury to the mechanic and may render the motorcycle unsafe for the rider and passenger.

**SUZUKI MOTOR CORPORATION**

© COPYRIGHT SUZUKI MOTOR CORPORATION 2006

## GROUP INDEX

<b>GENERAL INFORMATION</b>	<b>1</b>
<b>PERIODIC MAINTENANCE</b>	<b>2</b>
<b>ENGINE</b>	<b>3</b>
<b>DRIVELINE/AXLE</b>	<b>4</b>
<b>FI SYSTEM DIAGNOSIS</b>	<b>5</b>
<b>FUEL SYSTEM AND THROTTLE BODY</b>	<b>6</b>
<b>EXHAUST SYSTEM</b>	<b>7</b>
<b>COOLING AND LUBRICATION SYSTEM</b>	<b>8</b>
<b>CHASSIS</b>	<b>9</b>
<b>ELECTRICAL SYSTEM</b>	<b>10</b>
<b>SERVICING INFORMATION</b>	<b>11</b>
<b>EMISSION CONTROL INFORMATION</b>	<b>12</b>
<b>WIRING DIAGRAM</b>	<b>13</b>

## HOW TO USE THIS MANUAL TO LOCATE WHAT YOU ARE LOOKING FOR:

1. The text of this manual is divided into sections.
2. The section titles are listed in the GROUP INDEX.
3. Holding the manual as shown at the right will allow you to find the first page of the section easily.
4. The contents are listed on the first page of each section to help you find the item and page you need.

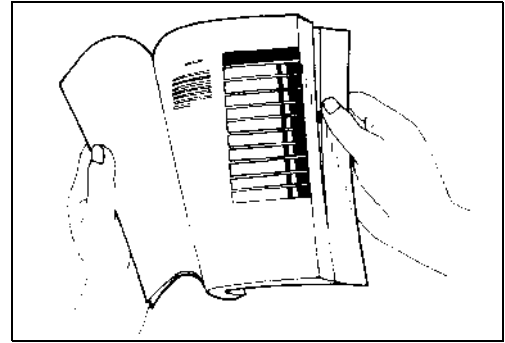

## COMPONENT PARTS AND WORK TO BE DONE

Under the name of each system or unit, is its exploded view. Work instructions and other service information such as the tightening torque, lubricating points and locking agent points, are provided.

Example: Front wheel

①	Brake disc
②	Dust seal
③	Bearing
④	Spacer
⑤	Collar
⑥	Front wheel
Ⓐ	Front axle
Ⓑ	Brake disc bolt





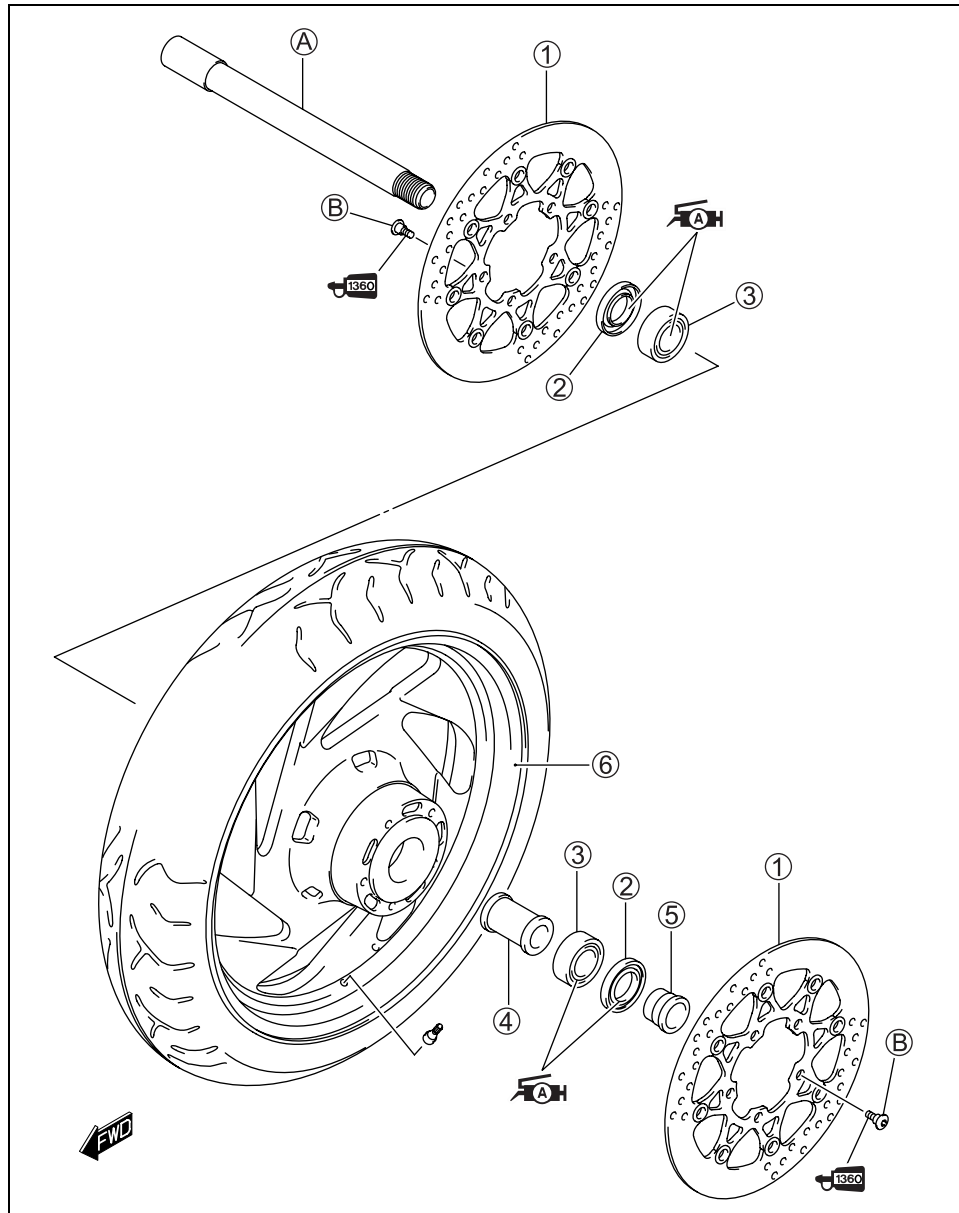















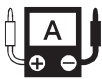

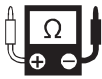
ITEM	N·m	kgf-m	lb-ft
Ⓐ	100	10.0	72.5
Ⓑ	23	2.3	16.5

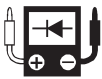

## SYMBOL

Listed in the table below are the symbols indicating instructions and other information necessary for servicing. The meaning of each symbol is also included in the table.

SYMBOL	DEFINITION	SYMBOL	DEFINITION
	Torque control required. Data beside it indicates specified torque.		Apply THREAD LOCK SUPER “1360” or equivalent. 99000-32130
	Apply oil. Use engine oil unless otherwise specified.		Use engine coolant or equivalent. 99000-99032-11X
	Apply molybdenum oil solution. (Mixture of engine oil and SUZUKI MOLY PASTE in a ratio of 1:1)		Use fork oil or equivalent. 99000-99044-L01
	Apply SUZUKI SUPER GREASE “A” or equivalent. 99000-25010		Apply or use brake fluid.
	Apply SUZUKI MOLY PASTE or equivalent. 99000-25140		Measure in voltage range.
	Apply SUZUKI SILICON GREASE or equivalent. 99000-25100		Measure in current range.
	Apply SUZUKI BOND “1215” or equivalent. 99000-31110		Measure in resistance range.
	Apply SUZUKI BOND “1207B” or equivalent. 99000-31140		Measure in diode test range.
	Apply THREAD LOCK SUPER “1303” or equivalent. 99000-32030		Measure in continuity test range.
	Apply THREAD LOCK SUPER “1322” or equivalent. 99000-32110		Use special tool.
	Apply THREAD LOCK “1342” or equivalent. 99000-32050		Indication of service data.



# ABBREVIATIONS USED IN THIS MANUAL

## A

ABDC	: After Bottom Dead Center
AC	: Alternating Current
ACL	: Air Cleaner, Air Cleaner Box
API	: American Petroleum Institute
ATDC	: After Top Dead Center
A/F	: Air Fuel Mixture

## B

BBDC	: Before Bottom Dead Center
BTDC	: Before Top Dead Center
B+	: Battery Positive Voltage

## C

CKP Sensor	: Crankshaft Position Sensor (CKPS)
CKT	: Circuit
CLP Switch	: Clutch Lever Position Switch (Clutch Switch)
CO	: Carbon Monoxide
CPU	: Central Processing Unit

## D

DC	: Direct Current
DMC	: Dealer Mode Coupler
DOHC	: Double Over Head Camshaft
DRL	: Daytime Running Light
DTC	: Diagnostic Trouble Code

## E

ECM	: Engine Control Module Engine Control Unit (ECU) (FI Control Unit)
ECT Sensor	: Engine Coolant Temperature Sensor (ECTS), Water Temp. Sensor (WTS)
EVAP	: Evaporative Emission
EVAP Canister	: Evaporative Emission Canister (Canister)
EXC System	: Exhaust Control System (EXCS)
EXC Valve	: Exhaust Control Valve (EXCV)
EXCV Actuator	: Exhaust Control Valve Actuator (EXCVA)

## F

FI	: Fuel Injection, Fuel Injector
FP	: Fuel Pump
FPR	: Fuel Pressure Regulator
FP Relay	: Fuel Pump Relay

## G

GEN	: Generator
GND	: Ground
GP Switch	: Gear Position Switch

## H

HC	: Hydrocarbons
----	----------------

## I

IAP Sensor	: Intake Air Pressure Sensor (IAPS) (MAP Sensor)
IAT Sensor	: Intake Air Temperature Sensor (IATS)
IG	: Ignition
ISC Valve	: Idle Speed Control Valve (ISCV)

## L

LCD	: Liquid Crystal Display
LED	: Light Emitting Diode (Malfunction Indicator Lamp)
LH	: Left Hand

## M

MAL-Code	: Malfunction Code (Diagnostic Code)
Max	: Maximum
MIL	: Malfunction Indicator Lamp (LED)
Min	: Minimum

## N

NOX	: Nitrogen Oxides
-----	-------------------

## **O**

OHC : Over Head Camshaft  
OPS : Oil Pressure Switch

## **P**

PCV : Positive Crankcase  
Ventilation (Crankcase Breather)

## **R**

RH : Right Hand  
ROM : Read Only Memory

## **S**

SAE : Society of Automotive Engineers  
SDS : Suzuki Diagnosis System  
STC System : Secondary Throttle Control System  
(STCS)  
STP Sensor : Secondary Throttle Position Sensor  
(STPS)  
ST Valve : Secondary Throttle Valve (STV)  
STV Actuator : Secondary Throttle Valve Actuator  
(STVA)

## **T**

TO Sensor : Tip-Over Sensor (TOS)  
TP Sensor : Throttle Position Sensor (TPS)

## WIRE COLOR

B	: Black	G	: Green	P	: Pink
Bl	: Blue	Gr	: Gray	R	: Red
Br	: Brown	Lbl	: Light blue	W	: White
Dg	: Dark green	Lg	: Light green	Y	: Yellow
Dgr	: Dark gray	O	: Orange		

B/Bl	: Black with Blue tracer	B/Br	: Black with Brown tracer
B/G	: Black with Green tracer	B/Lg	: Black with Light green tracer
B/R	: Black with Red tracer	B/W	: Black with White tracer
B/Y	: Black with Yellow tracer	Bl/B	: Blue with Black tracer
Bl/G	: Blue with Green tracer	Bl/R	: Blue with Red tracer
Bl/W	: Blue with White tracer	Bl/Y	: Blue with Yellow tracer
G/Bl	: Green with Blue tracer	G/B	: Green with Black tracer
G/W	: Green with White tracer	G/R	: Green with Red tracer
Gr/B	: Gray with Black tracer	G/Y	: Green with Yellow tracer
Gr/W	: Gray with White tracer	O/B	: Orange with Black tracer
O/G	: Orange with Green tracer	O/R	: Orange with Red tracer
O/W	: Orange with White tracer	O/Y	: Orange with Yellow tracer
P/B	: Pink with Black tracer	P/W	: Pink with White tracer
R/B	: Red with Black tracer	R/Bl	: Red with Blue tracer
R/G	: Red with Green tracer	W/Bl	: White with Blue tracer
R/Y	: Red with Yellow tracer	W/R	: White with Red tracer
W/B	: White with Black tracer	Y/B	: Yellow with Black tracer
W/G	: White with Green tracer	Y/G	: Yellow with Green tracer
Y/W	: Yellow with White tracer	Y/R	: Yellow with Red tracer

# GENERAL INFORMATION

1

## CONTENTS

<b>WARNING/CAUTION/NOTE</b> .....	<b>1- 2</b>
<b>GENERAL PRECAUTIONS</b> .....	<b>1- 2</b>
<b>SUZUKI VZR1800K6 ('06-MODEL)</b> .....	<b>1- 4</b>
<b>SERIAL NUMBER LOCATION</b> .....	<b>1- 4</b>
<b>FUEL, OIL AND ENGINE COOLANT RECOMMENDATION</b> .....	<b>1- 5</b>
<b>FUEL (FOR USA AND CANADA)</b> .....	<b>1- 5</b>
<b>FUEL (FOR OTHER COUNTRIES)</b> .....	<b>1- 5</b>
<b>ENGINE OIL (FOR USA)</b> .....	<b>1- 5</b>
<b>ENGINE OIL (FOR OTHER COUNTRIES)</b> .....	<b>1- 5</b>
<b>GEAR OIL (FINAL DRIVE GEAR OIL)</b> .....	<b>1- 5</b>
<b>BRAKE FLUID</b> .....	<b>1- 5</b>
<b>FRONT FORK OIL</b> .....	<b>1- 6</b>
<b>ENGINE COOLANT</b> .....	<b>1- 6</b>
<b>BREAK-IN PROCEDURES</b> .....	<b>1- 7</b>
<b>CYLINDER IDENTIFICATION</b> .....	<b>1- 7</b>
<b>INFORMATION LABELS</b> .....	<b>1- 8</b>
<b>SPECIFICATIONS</b> .....	<b>1- 9</b>
<b>DIMENSIONS AND DRY MASS</b> .....	<b>1- 9</b>
<b>ENGINE</b> .....	<b>1- 9</b>
<b>DRIVE TRAIN</b> .....	<b>1- 9</b>
<b>CHASSIS</b> .....	<b>1-10</b>
<b>ELECTRICAL</b> .....	<b>1-10</b>
<b>CAPACITIES</b> .....	<b>1-10</b>

## COUNTRY AND AREA CODES

The following codes stand for the applicable country(-ies) and area(-s).

CODE	COUNTRY or AREA	EFFECTIVE FRAME NO.
E-02	U.K.	JS1CA111200100001 –
E-03	U.S.A. (Except for California)	JS1VY53A 62100001 –
E-19	E.U.	JS1CA111100100001 –
E-19 (UF)	E.U.	JS1CA211100100001 –
E-24	Australia	JS1CA121300100001 –
E-28	Canada	JS1VY53A 62100001 –
E-33	California (U.S.A.)	JS1VY53A 62100001 –

## WARNING/CAUTION/NOTE

Please read this manual and follow its instructions carefully. To emphasize special information, the symbol and the words WARNING, CAUTION and NOTE have special meanings. Pay special attention to the messages highlighted by these signal words.

### **⚠ WARNING**

Indicates a potential hazard that could result in death or injury.

### **CAUTION**

Indicates a potential hazard that could result in motorcycle damage.

### *NOTE:*

*Indicates special information to make maintenance easier or instructions clearer.*

Please note, however, that the warnings and cautions contained in this manual cannot possibly cover all potential hazards relating to the servicing, or lack of servicing, of the motorcycle. In addition to the WARNINGS and CAUTIONS stated, you must use good judgement and basic mechanical safety principles. If you are unsure about how to perform a particular service operation, ask a more experienced mechanic for advice.

## GENERAL PRECAUTIONS

### **⚠ WARNING**

- \* Proper service and repair procedures are important for the safety of the service mechanic and the safety and reliability of the motorcycle.
- \* When 2 or more persons work together, pay attention to the safety of each other.
- \* When it is necessary to run the engine indoors, make sure that exhaust gas is forced outdoors.
- \* When working with toxic or flammable materials, make sure that the area you work in is well-ventilated and that you follow all of the material manufacturer's instructions.
- \* Never use gasoline as a cleaning solvent.
- \* To avoid getting burned, do not touch the engine, engine oil, radiator and exhaust system until they have cooled.
- \* After servicing the fuel, oil, water, exhaust or brake systems, check all lines and fittings related to the system for leaks.

**CAUTION**

- \* If parts replacement is necessary, replace the parts with Suzuki Genuine Parts or their equivalent.
  - \* When removing parts that are to be reused, keep them arranged in an orderly manner so that they may be reinstalled in the proper order and orientation.
  - \* Be sure to use special tools when instructed.
  - \* Make sure that all parts used in reassembly are clean. Lubricate them when specified.
  - \* Use the specified lubricant, bond, or sealant.
  - \* When removing the battery, disconnect the negative cable first and then the positive cable.
  - \* When reconnecting the battery, connect the positive cable first and then the negative cable, and replace the terminal cover on the positive terminal.
  - \* When performing service to electrical parts, if the service procedures do not require use of battery power, disconnect the negative cable from the battery.
  - \* When tightening the cylinder head or case bolts and nuts, tighten the larger sizes first. Always tighten the bolts and nuts diagonally from the inside toward outside and to the specified tightening torque.
  - \* Whenever you remove oil seals, gaskets, packing, O-rings, locking washers, self-locking nuts, cotter pins, circlips and certain other parts as specified, be sure to replace them with new ones. Also, before installing these new parts, be sure to remove any left over material from the mating surfaces.
  - \* Never reuse a circlip. When installing a new circlip, take care not to expand the end gap larger than required to slip the circlip over the shaft. After installing a circlip, always ensure that it is completely seated in its groove and securely fitted.
  - \* Use a torque wrench to tighten fasteners to the specified torque. Wipe off grease and oil if a thread is smeared with them.
  - \* After reassembling, check parts for tightness and proper operation.
- 
- \* To protect the environment, do not unlawfully dispose of used motor oil, engine coolant and other fluids: batteries and tires.
  - \* To protect Earth's natural resources, properly dispose of used motorcycle and parts.

## SUZUKI VZR1800K6 ('06-MODEL)

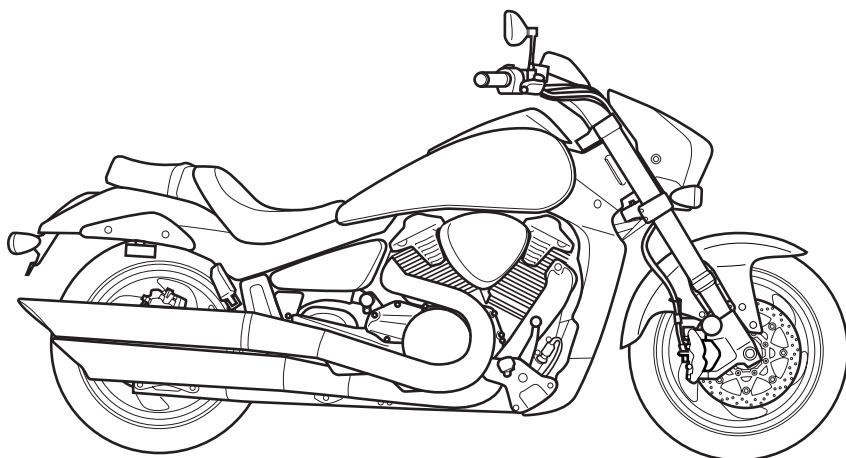

RIGHT SIDE

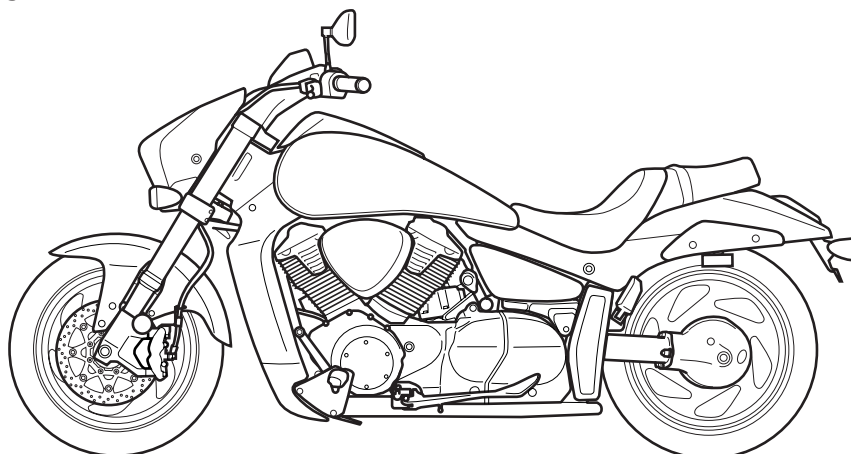

LEFT SIDE

- Difference between illustration and actual motorcycle may exist depending on the markets.

## SERIAL NUMBER LOCATION

The frame serial number or V.I.N. (Vehicle Identification Number) ① is stamped on the right side of the steering head pipe. The engine serial number ② is located on the right side of the crankcase. These numbers are required especially for registering the machine and ordering spare parts.

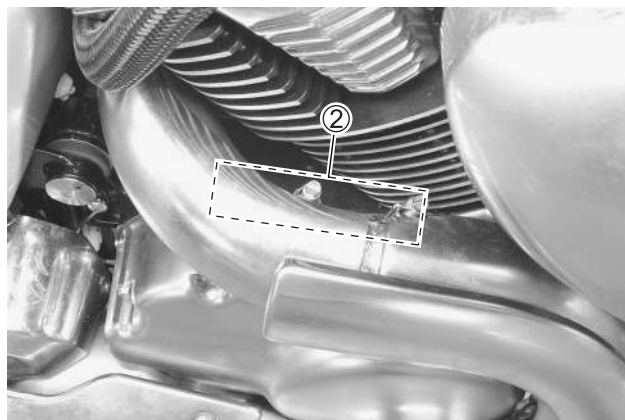

## FUEL, OIL AND ENGINE COOLANT RECOMMENDATION

### FUEL (FOR USA AND CANADA)

Use only unleaded gasoline of at least 90 pump octane (R/2 + M/2).

Gasoline containing MTBE (Methyl Tertiary Butyl Ether), less than 10% ethanol, or less than 5% methanol with appropriate cosolvents and corrosion inhibitor is permissible.

### FUEL (FOR OTHER COUNTRIES)

Gasoline used should be graded 95 octane (Research Method) or higher. Unleaded gasoline is recommended.

### ENGINE OIL (FOR USA)

Oil quality is a major contributor to your engine's performance and life. Always select good quality engine oil. Suzuki recommends the use of SUZUKI PERFORMANCE 4 MOTOR OIL or equivalent engine oil. Use of API SF/SG or SH/SJ with JASO MA.

Suzuki recommends the use of SAE 10W-40 engine oil. If SAE 10W-40 engine oil is not available, select an alternative according to the following chart.

### ENGINE OIL (FOR OTHER COUNTRIES)

Oil quality is a major contributor to your engine's performance and life. Always select good quality engine oil. Use of API SF/SG or SH/SJ with JASO MA.

Suzuki recommends the use of SAE 10W-40 engine oil. If SAE 10W-40 engine oil is not available, select an alternative according to the right chart.

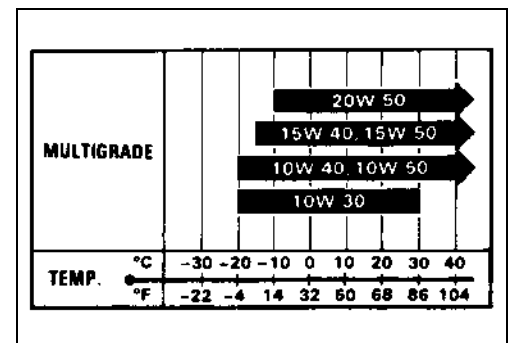

### GEAR OIL (FINAL DRIVE GEAR OIL)

Use SAE 90 hypoid gear oil which is rated GL-5 under API classification system. If you operate the motorcycle where ambient temperature is below 0 °C (32 °F), use SAE 80 hypoid gear oil.

### BRAKE FLUID

Specification and classification: DOT 4

#### **⚠ WARNING**

Since the brake system of this motorcycle is filled with a glycol-based brake fluid by the manufacturer, do not use or mix different types of fluid such as silicone-based and petroleum-based fluid for refilling the system, otherwise serious damage will result.

Do not use any brake fluid taken from old or used or unsealed containers.

Never re-use brake fluid left over from a previous servicing, which has been stored for a long period.



## FRONT FORK OIL

Use fork oil L01 or an equivalent fork oil.

## ENGINE COOLANT

Use an anti-freeze/engine coolant compatible with an aluminum radiator, mixed with distilled water only.

## WATER FOR MIXING

Use distilled water only. Water other than distilled water can corrode and clog the aluminum radiator.

## ANTI-FREEZE/ENGINE COOLANT

The engine coolant performs as a corrosion and rust inhibitor as well as anti-freeze. Therefore, the engine coolant should be used at all times even though the atmospheric temperature in your area does not go down to freezing point.

Suzuki recommends the use of SUZUKI COOLANT anti-freeze/engine coolant. If this is not available, use an equivalent which is compatible with an aluminum radiator.

## LIQUID AMOUNT OF WATER/ENGINE COOLANT

**Solution capacity (total): Approx. 2 700 ml (2.9/2.4 US/Imp qt)**

For engine coolant mixture information, refer to cooling system section in page 8-2.

### **CAUTION**

**Mixing of anti-freeze/engine coolant should be limited to 60%. Mixing beyond it would reduce its efficiency. If the anti-freeze/engine coolant mixing ratio is below 50%, rust inhabiting performance is greatly reduced. Be sure to mix it above 50% even though the atmospheric temperature does not go down to the freezing point.**

## BREAK-IN PROCEDURES

During manufacture only the best possible materials are used and all machined parts are finished to a very high standard but it is still necessary to allow the moving parts to “BREAK-IN” before subjecting the engine to maximum stresses. The future performance and reliability of the engine depends on the care and restraint exercised during its early life. The general rules are as follows.

- Keep to these break-in engine speed limits:

**Initial 800 km ( 500 miles): Below 3 500 r/min**

**Up to 1 600 km (1 000 miles): Below 5 500 r/min**

**Over to 1 600 km (1 000 miles): Below 7 500 r/min**

- Upon reaching an odometer reading of 1 600 km (1 000 miles) you can subject the motorcycle to full throttle operation.  
However, do not exceed 7 500 r/min at any time.

## CYLINDER IDENTIFICATION

The cylinders of this engine are identified as #1 and #2 cylinder, as counted from rear to front (as viewed by the rider on the seat.)



## INFORMATION LABELS

	VZR1800	VZR1800UF
① Noise label	A (For E-03, 24, 33)	
② Information label	A (For E-03, 28, 33)	
③ Vacuum hose routing label	A (For E-33)	
④ Fuel caution label	A (For E-02, 24)	
⑤ Fuel information label	A	A
⑥ Manual notice label	A (For E-03, 33)	
⑦ Tire information label	A	A
⑧ General warning label	A	A
⑨ ICES Canada label	A (For E-28)	
⑩ I.D. plate	A (Except E-02, 19, 24)	A
⑪ E-19 I.D. label		A
⑫ Safety plate	A (For E-03, 28, 33)	
⑬ Gearshift label	A	A

A: Attached

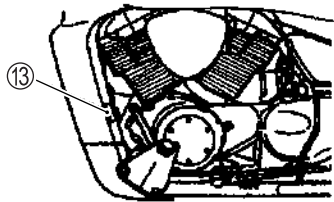

Engine (Left side)

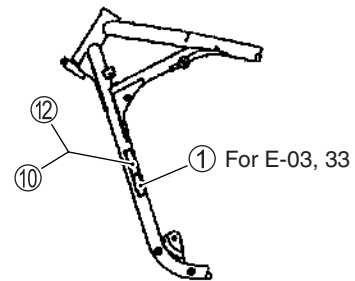

Frame pipe (Left side)

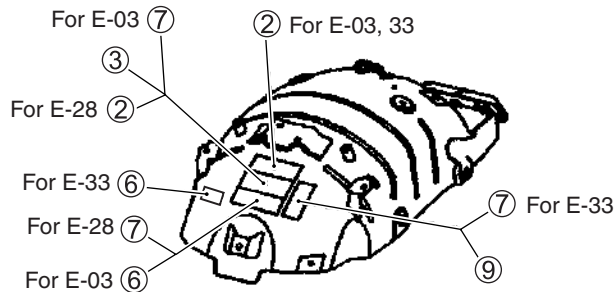

Rear fender (For E-03, 28, 33)

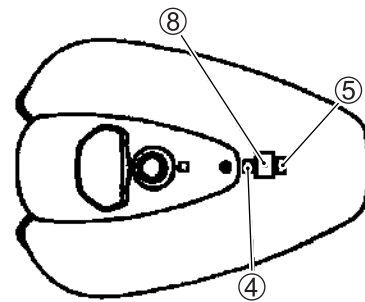

Fuel tank

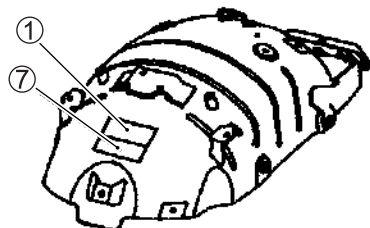

Rear fender (For E-24)

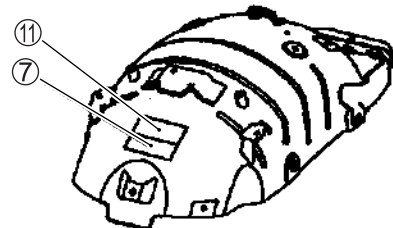

Rear fender (For E-02, 19)

## SPECIFICATIONS

### DIMENSIONS AND DRY MASS

Overall length .....	2 450 mm (96.5 in) .....	For E-03, 33
	2 480 mm (97.6 in) .....	For others
Overall width .....	875 mm (34.4 in)	
Overall height .....	1 185 mm (46.7 in)	
Wheelbase .....	1 710 mm (67.3 in)	
Ground clearance.....	130 mm (5.1 in)	
Seat height .....	705 mm (27.8 in)	
Dry mass .....	315 kg (694 lbs)	

### ENGINE

Type .....	4-stroke, liquid-cooled, DOHC, 54° degree, V-twin
Number of cylinders .....	2
Bore.....	112.0 mm (4.409 in)
Stroke.....	90.5 mm (3.563 in)
Displacement .....	1 783 cm <sup>3</sup> (108.8 cu. in)
Compression ratio .....	10.5 : 1
Fuel system.....	Fuel injection
Air cleaner .....	Non-woven fabric element
Starter system .....	Electric
Lubrication system .....	Semi-Dry sump
Idle speed.....	900 ± 100 r/min

### DRIVE TRAIN

Clutch .....	Wet multi-plate type
Transmission.....	5-speed constant mesh
Gearshift pattern .....	1-down, 4-up
Primary reduction ratio .....	1.757 (58/33)
Gear ratios, Low .....	2.187 (35/16)
2nd.....	1.400 (28/20)
3rd.....	1.038 (27/26)
4th.....	0.827 (24/29)
Top.....	0.685 (24/35)
Final reduction ratio.....	2.823 (18/17 × 32/12)
Drive system .....	Shaft drive

## CHASSIS

Front suspension .....	Inverted telescopic, coil spring, oil damped
Rear suspension .....	Link type, coil spring, oil damped
Front fork stroke .....	130 mm (5.1 in)
Rear wheel travel .....	118 mm (4.6 in)
Caster .....	31° 15'
Trail .....	124 mm (4.9 in)
Steering angle .....	37° (right & left)
Turning radius .....	3.3 m (10.8 ft)
Front brake .....	Disc brake, twin
Rear brake .....	Disc brake
Front tire size .....	130/70R18M/C 63V, tubeless
Rear tire size .....	240/40R18M/C 79V, tubeless

## ELECTRICAL

Ignition type .....	Electronic ignition (Transistorized)
Ignition timing .....	5° B.T.D.C at 900 r/min
Spark plug .....	NGK: CR8EK or DENSO: U24ETR
Battery .....	12 V 64.8 kC (18 Ah)/10 HR
Generator .....	Three-phase A.C. Generator
Main fuse .....	30 A
Fuse .....	10/10/10/15/15/15 A
Headlight .....	12 V 60/55 W (H4)
Position light .....	12 V 5 W ..... For E-02, 19, 24
Front turn signal/position light .....	12 V 21/5 W ..... For E-03, 28, 33
Front turn signal light .....	12 V 21 W ..... For the others
Rear turn signal light .....	12 V 21 W
License light .....	12 V 5 W
Brake light/Taillight .....	LED
Speedometer light .....	LED
Tachometer light .....	LED
Fuel level indicator light .....	LED
Turn signal indicator light .....	LED
Neutral indicator light .....	LED
High beam indicator light .....	LED
Coolant temperature/Oil pressure Indicator light .....	LED
FI indicator light .....	LED

## CAPACITIES

Fuel tank capacity .....	18.5 L (4.9/4.1 US/Imp gal) ..... For E-33
	19.5 L (5.2/4.3 US/Imp gal) ..... For the others
Engine oil, oil change .....	3 400 ml (3.6/3.0 US/Imp qt)
with filter change .....	3 600 ml (3.8/3.2 US/Imp qt)
overhaul .....	4 700 ml (5.0/4.1 US/Imp qt)
Final gear oil .....	200 – 220 ml (6.8/7.0 – 7.4/7.7 US/Imp oz)
Coolant .....	2.7 L (2.9/2.4 US/Imp qt)

These specifications are subject to change without notice.

# PERIODIC MAINTENANCE

## CONTENTS

<b>PERIODIC MAINTENANCE SCHEDULE</b> .....	<b>2- 2</b>
<b>PERIODIC MAINTENANCE CHART</b> .....	<b>2- 2</b>
<b>LUBRICATION POINTS</b> .....	<b>2- 3</b>
<b>MAINTENANCE AND TUNE-UP PROCEDURES</b> .....	<b>2- 4</b>
<b>AIR CLEANER</b> .....	<b>2- 4</b>
<b>EXHAUST PIPE BOLTS AND MUFFLER BOLTS</b> .....	<b>2- 6</b>
<b>EXHAUST CONTROL VALVE</b> .....	<b>2- 7</b>
<b>VALVE CLEARANCE</b> .....	<b>2- 8</b>
<b>SPARK PLUG</b> .....	<b>2-13</b>
<b>FUEL LINE</b> .....	<b>2-16</b>
<b>EVAPORATIVE EMISSION CONTROL SYSTEM (E-33 ONLY)</b> .....	<b>2-16</b>
<b>ENGINE OIL AND OIL FILTER</b> .....	<b>2-17</b>
<b>FINAL GEAR OIL</b> .....	<b>2-19</b>
<b>THROTTLE CABLE PLAY</b> .....	<b>2-19</b>
<b>PAIR (AIR SUPPLY) SYSTEM</b> .....	<b>2-19</b>
<b>THROTTLE VALVE SYNCHRONIZATION</b> .....	<b>2-20</b>
<b>COOLING SYSTEM</b> .....	<b>2-20</b>
<b>CLUTCH CABLE PLAY</b> .....	<b>2-22</b>
<b>BRAKE</b> .....	<b>2-23</b>
<b>TIRES</b> .....	<b>2-27</b>
<b>STEERING</b> .....	<b>2-28</b>
<b>FRONT FORK</b> .....	<b>2-28</b>
<b>REAR SUSPENSION</b> .....	<b>2-29</b>
<b>CHASSIS BOLTS AND NUTS</b> .....	<b>2-29</b>
<b>COMPRESSION PRESSURE CHECK</b> .....	<b>2-31</b>
<b>COMPRESSION TEST PROCEDURE</b> .....	<b>2-31</b>
<b>OIL PRESSURE CHECK</b> .....	<b>2-32</b>
<b>SDS CHECK</b> .....	<b>2-33</b>

## PERIODIC MAINTENANCE SCHEDULE

The chart below lists the recommended intervals for all the required periodic service work necessary to keep the motorcycle operating at peak performance and economy. Mileages are expressed in terms of kilometers, miles and time for your convenience.

**NOTE:**

More frequent servicing may be required on motorcycles that are used under severe conditions.

### PERIODIC MAINTENANCE CHART

Item	Interval	km	1 000	6 000	12 000	18 000	24 000
		miles	600	4 000	7 500	11 000	14 500
		months	2	12	24	36	48
Air cleaner element		—	I	I	R	I	
Exhaust pipe bolts and muffler bolts		T	—	T	—	T	
Exhaust control valve		I	—	I	—	I	
Valve clearance		—	—	—	—	I	
Spark plugs		—	I	R	I	R	
Fuel line		—	I	I	I	I	
Evaporative emission control system (E-33 only)		—	—	I	—	I	
Engine oil		R	R	R	R	R	
Engine oil filter		R	—	—	R	—	
Final gear oil		R	—	I	—	I	
Throttle cable play		I	I	I	I	I	
PAIR (air supply) system		—	—	I	—	I	
Throttle valve synchronization		I (E-33 only)	—	I	—	I	
Engine coolant		Replace every 2 years					
Radiator hose		—	I	I	I	I	
Clutch cable play		—	I	I	I	I	
Brakes		I	I	I	I	I	
Brake hoses		—	I	I	I	I	
		Replace every 4 years					
Brake fluid		—	I	I	I	I	
		Replace every 2 years					
Tires		—	I	I	I	I	
Steering		I	—	I	—	I	
Front fork		—	—	I	—	I	
Rear suspension		—	—	I	—	I	
Chassis bolts and nuts		T	T	T	T	T	

**NOTE:**

I = Inspect and clean, adjust, replace or lubricate as necessary

R = Replace

T = Tighten

## LUBRICATION POINTS

Proper lubrication is important for smooth operation and long life of each working part of the motorcycle. Major lubrication points are indicated below.

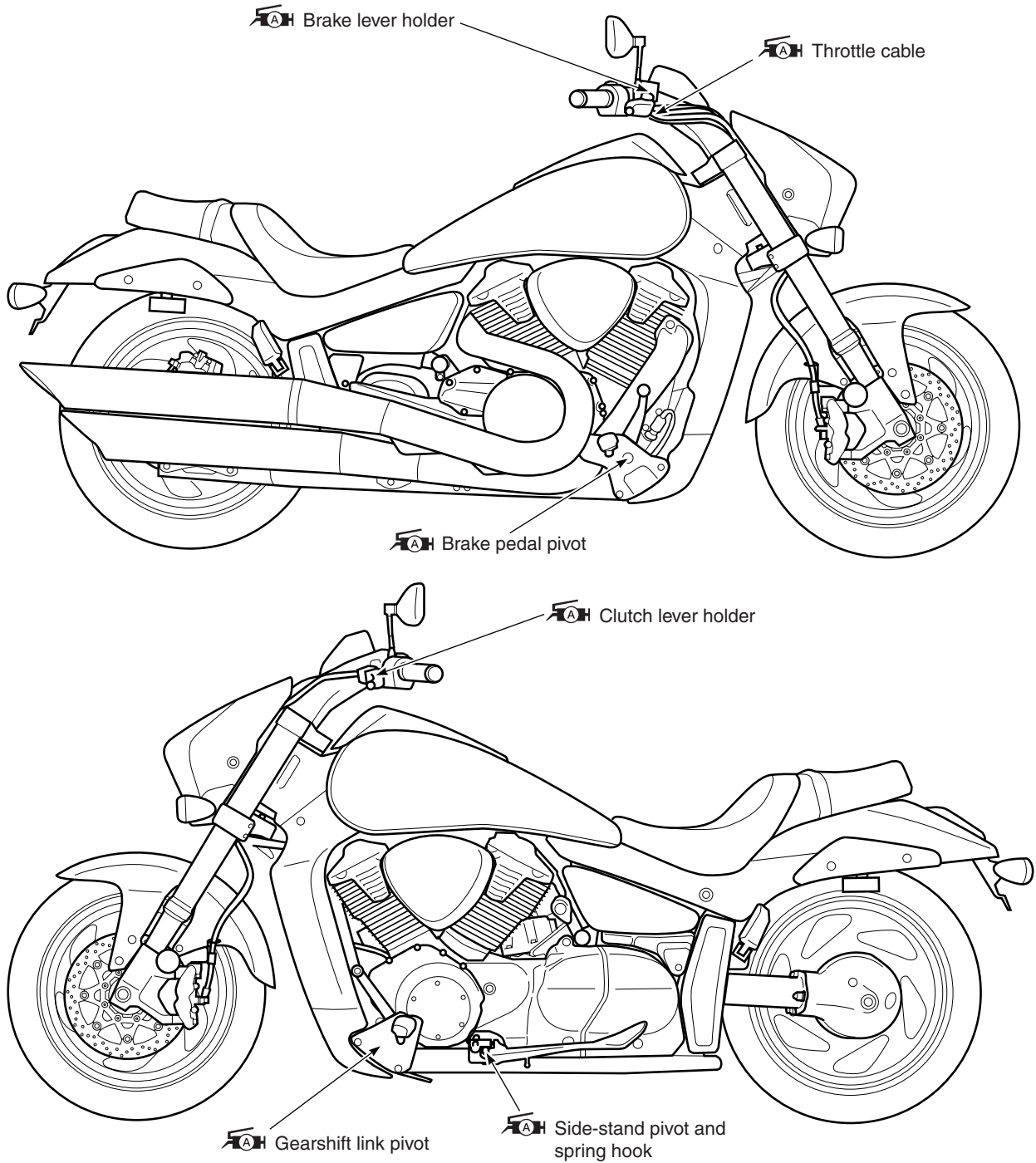

### NOTE:

- \* Before lubricating each part, clean off any rusty spots and wipe off any grease, oil, dirt or grime.
- \* Lubricate exposed parts which are subject to rust, with a rust preventative spray whenever the motorcycle has been operated under wet or rainy conditions.



## MAINTENANCE AND TUNE-UP PROCEDURES

This section describes the servicing procedures for each item of the Periodic Maintenance requirements.

### AIR CLEANER

**Inspect every 6 000 km (4 000 miles, 12 months) and replace every 18 000 km (11 000 miles, 36 months).**

- Remove the right and left air cleaner box bolts.

**NOTE:**

“☆” indicates hook location.

- Loosen the air cleaner box clamp screw and disconnect the drain tube ①.
- Remove the air cleaner box.

- Remove the air cleaner case ②.

- Remove the air cleaner element ③.

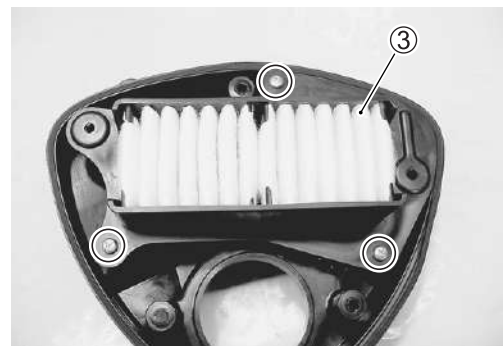
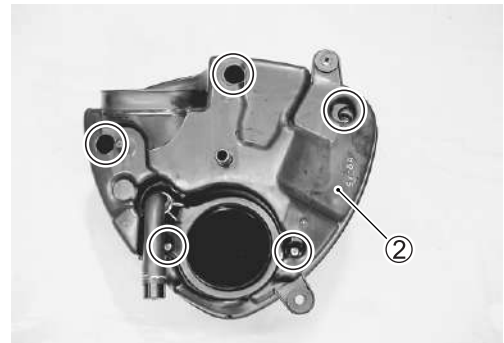
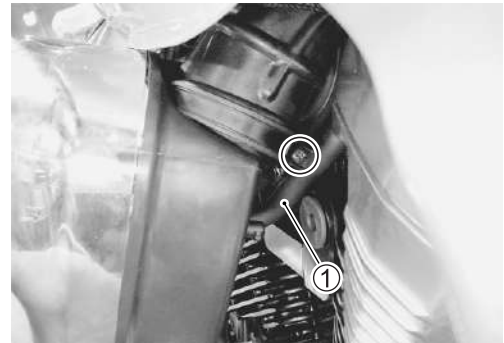
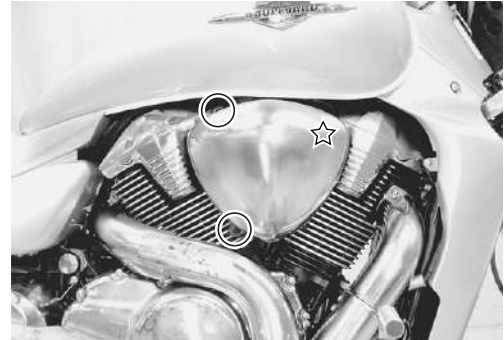

- Carefully use air hose to blow the dust from the cleaner element.

**CAUTION**

**Always use air pressure on the center air cleaner side of the air cleaner element. If air pressure is used on the other side, dirt will be forced into the pores of the air cleaner element thus restricting air flow through the air cleaner element.**

**NOTE:**

*If driving under dusty conditions, clean the air cleaner element more frequently. Make sure that the air cleaner is in good condition at all times. The life of the engine depends largely on this component.*

- Install the cleaned or new air cleaner element in the reverse order of removal.

**NOTE:**

*When cleaning the air cleaner element, drain water from the air cleaner by removing the drain plug.*



## EXHAUST PIPE BOLTS AND MUFFLER BOLTS

Tighten initially at 1 000 km (600 miles, 2 months) and every 12 000 km (7 500 miles, 24 months) thereafter.

- Tighten the exhaust pipe bolts, muffler mounting bolt and nut to the specified torque.

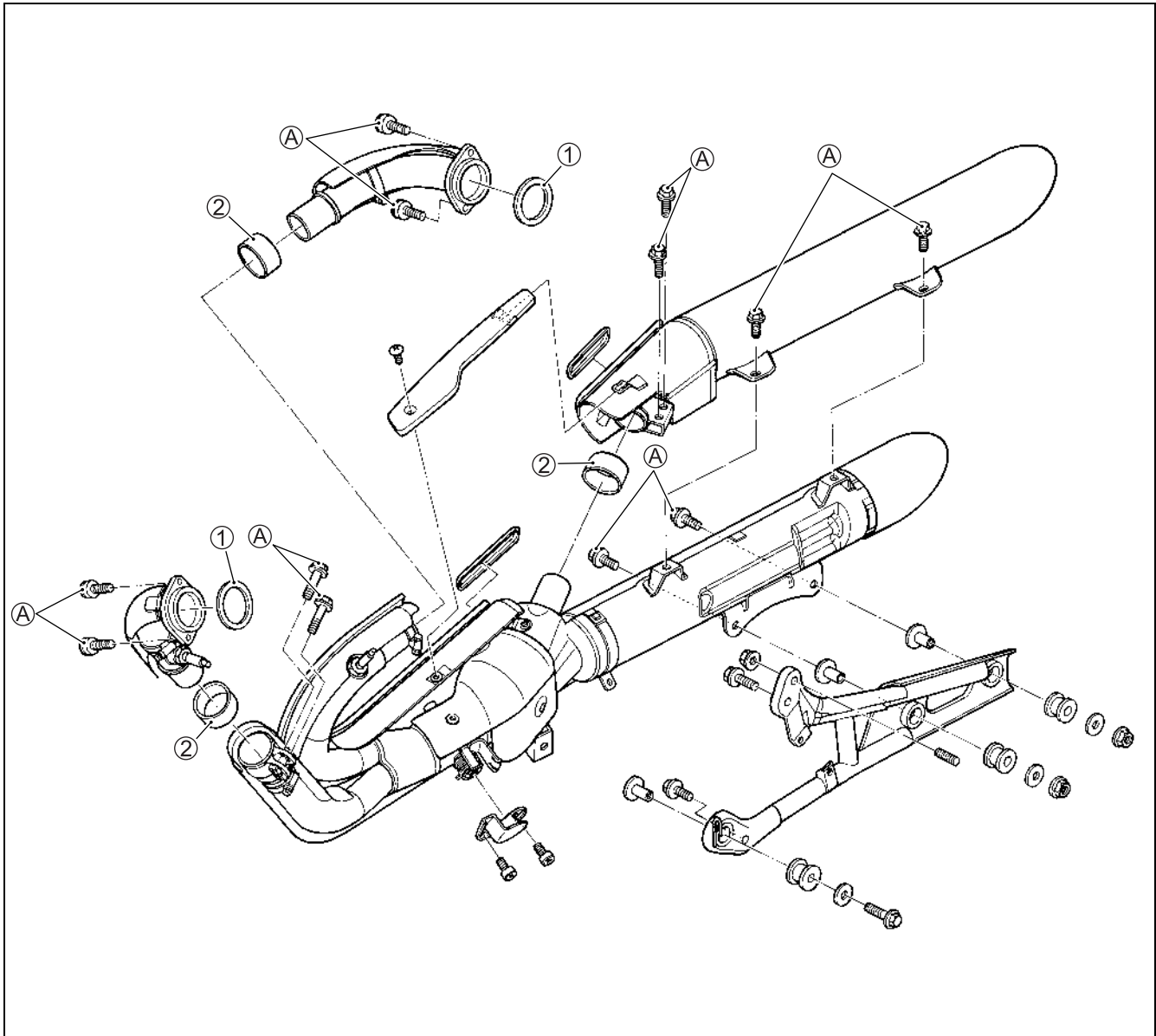

① Gasket      ② Exhaust pipe connector



ITEM	N·m	kgf·m	lb·ft
(A)	23	2.3	16.5

### CAUTION

Replace the gaskets and exhaust pipe connector with the new ones.

## EXHAUST CONTROL VALVE

Inspect initially at 1 000 km (600 miles, 2 months) and every 12 000 km (7 500 miles, 24 months) thereafter.

- Remove the rubber cover ①.
- Check the exhaust control valve actuator ② for its movement when the ignition switch is turned on. If the exhaust valve actuator does not move, check exhaust valve actuator electrical circuit and exhaust valve carbon sticking. Check the exhaust control cable play. (☞ 7-12)
- Remove the two bolts and cover.

- Check the lock nuts tightness. If the lock nuts are loose, adjust the cable play and tighten the lock nuts.

### NOTE:

Install the rubber cover ① correctly after inspecting it.

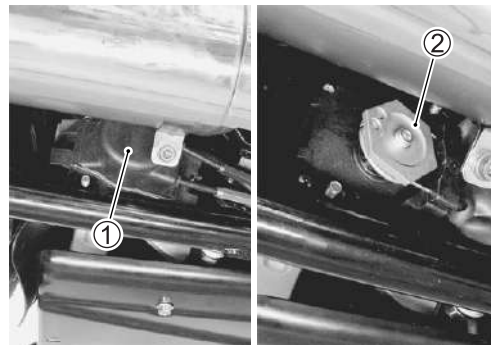

## VALVE CLEARANCE

Inspect every 24 000 km (14 500 miles, 48 months).

- Remove the frame side covers. (☞ 9-5)
- Remove the fuel tank. (☞ 6-3)
- Remove the frame head covers and radiator covers. (☞ 9-6)
- Remove the air cleaner chamber. (☞ 6-13)
- Remove the all spark plugs. (☞ 2-13)
- Remove the right and left cylinder head cover brackets. (☞ 3-14)
- Disconnect the PAIR hoses ①.
- Disconnect the lead wire ② from to frame.
- Remove the front and rear PAIR reed valve covers ③.
- Remove the cylinder head covers.

### NOTE:

Remove the front cylinder head cover to left side and rear cylinder head cover to right side.

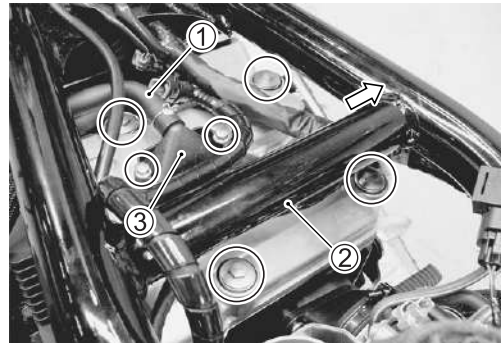
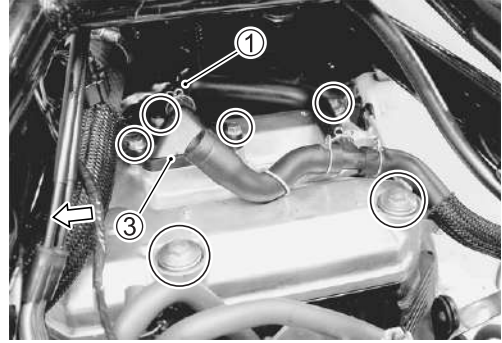

The valve clearance specification is different for intake and exhaust valves. Valve clearance must be checked and adjusted, 1) at the time of periodic inspection, 2) when the valve mechanism is serviced, and 3) when the camshafts are removed for servicing.

### DATA Valve clearance (when cold):

Standard: IN. : 0.09 – 0.16 mm (0.004 – 0.006 in)

EX. : 0.20 – 0.30 mm (0.008 – 0.012 in)

### NOTE:

- \* The tappet clearance should be taken when each cylinder is at Top Dead Center (TDC) of compression stroke.
- \* The cams (IN & EX) on the front cylinder at position A show the front cylinder at TDC of compression stroke.
- \* The cams (IN & EX) on the rear cylinder at position B show the rear cylinder at TDC of compression stroke.
- \* The clearance specification is for COLD state.
- \* To turn the crankshaft for clearance checking, be sure to use a wrench, and rotate in the normal running direction. All spark plugs should be removed.

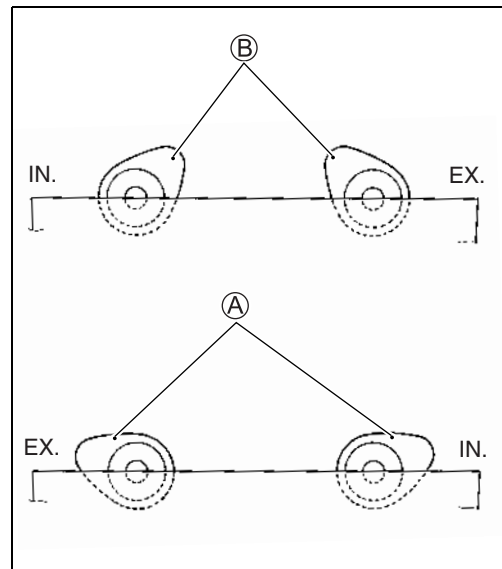



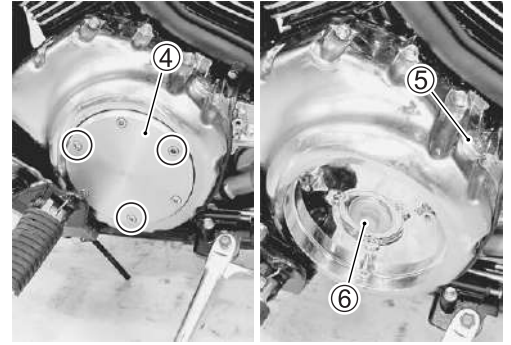

- Remove the secondary gear case cover. (☞ 3-6)
- Remove the generator cover cap ④, valve timing inspection plug ⑤ and generator cover plug ⑥.

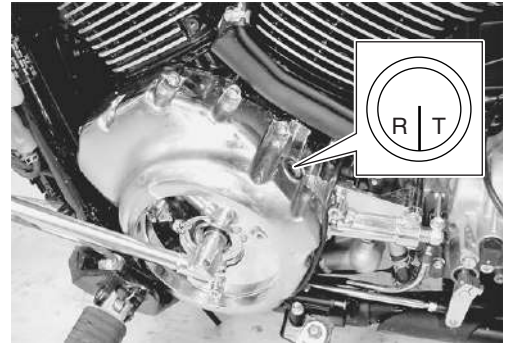

- Turn the crankshaft to set the #1 (Rear) cylinder at TDC of compression stroke. (Align the “R | T” line on the generator rotor to the center of valve timing inspection hole and also bring the camshafts to the position as shown in page 2-8.)



- To inspect the #1 (Rear) cylinder tappet clearance, use a thickness gauge between the tappet and the cam. If the clearance is out of specification, adjust it into the specified range.

 **09900-20803: Thickness gauge**

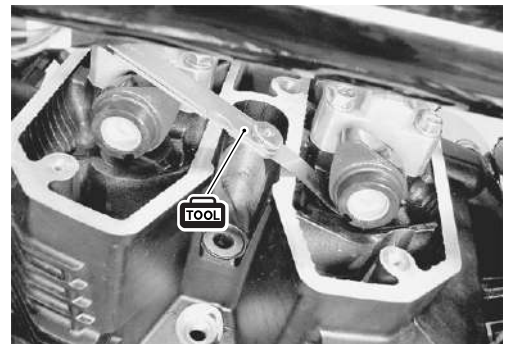

- Turn the crankshaft 486 degrees (1-1/3 turns) to set the #2 (Front) cylinder at TDC of compression stroke. (Align the “F | T” line on the generator rotor to the center of valve timing inspection hole and also bring the camshafts to the position as shown in page 2-8.)



- Inspect the #2 (Front) cylinder tappet clearance as the same manner of #1 (Rear) cylinder and adjust the clearance if necessary.

 **09900-20803: Thickness gauge**

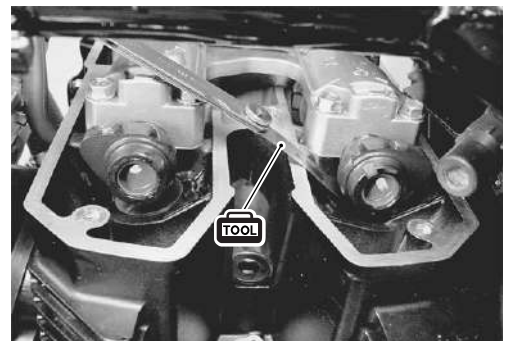

### VALVE CLEARANCE ADJUSTMENT

The clearance is adjusted by replacing the existing tappet shim by a thicker or thinner shim.

- Remove the intake or exhaust camshafts. (☞ 3-14 to -15 and 3-17 to -18)
- Remove the tappet and shim by fingers or magnetic hand.
- Check the figures printed on the shim. These figures indicate the thickness of the shim, as illustrated.
- Select a replacement shim that will provide a clearance within the specified range. For the purpose of this adjustment, a total of 25 sizes of tappet shim are available ranging from 2.30 to 3.50 mm in steps of 0.05 mm. Fit the selected shim to the valve stem end, with numbers toward tappet. Be sure to check shim size with micrometer to ensure its size. Refer to the tappet shim selection table (☞ 2-11 and -12) for details.

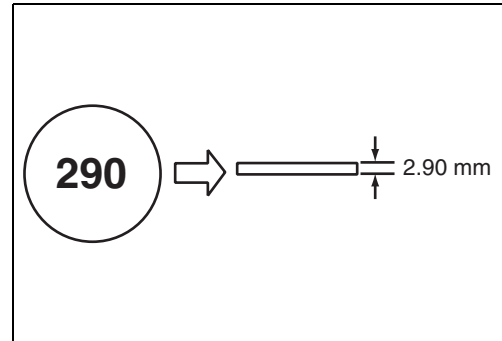
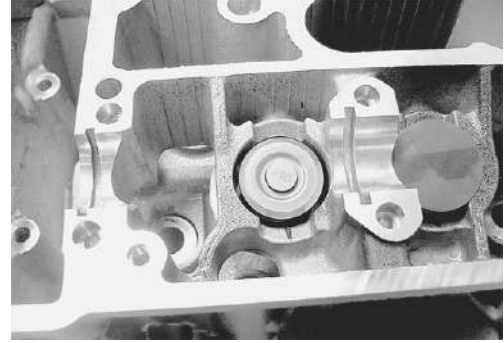

#### NOTE:

- \* Be sure to apply engine oil to tappet shim top and bottom faces.
- \* When seating the tappet shim, be sure the figure printed surface faces the tappet.

#### NOTE:

Reinstall the camshafts in the specified manner. (☞ 3-102 to -109)

- After replacing the tappet shim and camshafts, rotate the engine so that the tappet is depressed fully. This will squeeze out oil trapped between the shim and the tappet that could cause an incorrect measurement. Then check the clearance again to confirm that it is within the specified range.
- After finishing the valve clearance adjustment, reinstall the following items.
  - \* Cylinder head cover (☞ 3-109)
  - \* PAIR control solenoid valve (☞ 12-7)
  - \* Spark plug and plug cap (☞ 2-16)
  - \* Valve timing inspection plug and generator cover plug (☞ 3-111)

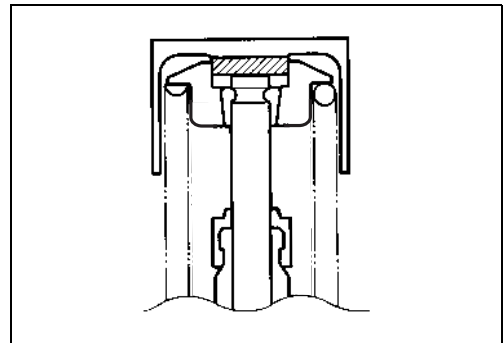

(INTAKE SIDE)

TAPPET SHIM SELECTION TABLE [INTAKE]  
TAPPET SHIM NO. (12892-41C00-XXX)

MEASURED TAPPET CLEARANCE (mm)	OPTION																TAPPET SHIM SET (12800-41810)															
	SUFFIX NO.	230	235	240	245	250	255	260	265	270	275	280	285	290	295	300	305	310	315	320	325	330	335	340	345	350						
0.00 - 0.04	2.30	2.35	2.40	2.45	2.50	2.55	2.60	2.65	2.70	2.75	2.80	2.85	2.90	2.95	3.00	3.05	3.10	3.15	3.20	3.25	3.30	3.35	3.40	3.45	3.50							
0.05 - 0.08	2.30	2.35	2.40	2.45	2.50	2.55	2.60	2.65	2.70	2.75	2.80	2.85	2.90	2.95	3.00	3.05	3.10	3.15	3.20	3.25	3.30	3.35	3.40	3.45	3.50							
0.09 - 0.16	2.35	2.40	2.45	2.50	2.55	2.60	2.65	2.70	2.75	2.80	2.85	2.90	2.95	3.00	3.05	3.10	3.15	3.20	3.25	3.30	3.35	3.40	3.45	3.50								
0.17 - 0.21	2.40	2.45	2.50	2.55	2.60	2.65	2.70	2.75	2.80	2.85	2.90	2.95	3.00	3.05	3.10	3.15	3.20	3.25	3.30	3.35	3.40	3.45	3.50									
0.22 - 0.26	2.45	2.50	2.55	2.60	2.65	2.70	2.75	2.80	2.85	2.90	2.95	3.00	3.05	3.10	3.15	3.20	3.25	3.30	3.35	3.40	3.45	3.50										
0.27 - 0.31	2.50	2.55	2.60	2.65	2.70	2.75	2.80	2.85	2.90	2.95	3.00	3.05	3.10	3.15	3.20	3.25	3.30	3.35	3.40	3.45	3.50											
0.32 - 0.36	2.55	2.60	2.65	2.70	2.75	2.80	2.85	2.90	2.95	3.00	3.05	3.10	3.15	3.20	3.25	3.30	3.35	3.40	3.45	3.50												
0.37 - 0.41	2.60	2.65	2.70	2.75	2.80	2.85	2.90	2.95	3.00	3.05	3.10	3.15	3.20	3.25	3.30	3.35	3.40	3.45	3.50													
0.42 - 0.46	2.65	2.70	2.75	2.80	2.85	2.90	2.95	3.00	3.05	3.10	3.15	3.20	3.25	3.30	3.35	3.40	3.45	3.50														
0.47 - 0.51	2.70	2.75	2.80	2.85	2.90	2.95	3.00	3.05	3.10	3.15	3.20	3.25	3.30	3.35	3.40	3.45	3.50															
0.52 - 0.56	2.75	2.80	2.85	2.90	2.95	3.00	3.05	3.10	3.15	3.20	3.25	3.30	3.35	3.40	3.45	3.50																
0.57 - 0.61	2.80	2.85	2.90	2.95	3.00	3.05	3.10	3.15	3.20	3.25	3.30	3.35	3.40	3.45	3.50																	
0.62 - 0.66	2.85	2.90	2.95	3.00	3.05	3.10	3.15	3.20	3.25	3.30	3.35	3.40	3.45	3.50																		
0.67 - 0.71	2.90	2.95	3.00	3.05	3.10	3.15	3.20	3.25	3.30	3.35	3.40	3.45	3.50																			
0.72 - 0.76	2.95	3.00	3.05	3.10	3.15	3.20	3.25	3.30	3.35	3.40	3.45	3.50																				
0.77 - 0.81	3.00	3.05	3.10	3.15	3.20	3.25	3.30	3.35	3.40	3.45	3.50																					
0.82 - 0.86	3.05	3.10	3.15	3.20	3.25	3.30	3.35	3.40	3.45	3.50																						
0.87 - 0.91	3.10	3.15	3.20	3.25	3.30	3.35	3.40	3.45	3.50																							
0.92 - 0.96	3.15	3.20	3.25	3.30	3.35	3.40	3.45	3.50																								
0.97 - 1.01	3.20	3.25	3.30	3.35	3.40	3.45	3.50																									
1.02 - 1.06	3.25	3.30	3.35	3.40	3.45	3.50																										
1.07 - 1.11	3.30	3.35	3.40	3.45	3.50																											
1.12 - 1.16	3.35	3.40	3.45	3.50																												
1.17 - 1.21	3.40	3.45	3.50																													
1.22 - 1.26	3.45	3.50																														
1.27 - 1.31	3.50																															
1.32 - 1.36																																

SPECIFIED CLEARANCE/NO ADJUSTMENT REQUIRED

**HOW TO USE THIS CHART:**  
 I. Measure tappet clearance. "ENGINE IS COLD"  
 II. Measure present shim size.  
 III. Match clearance in vertical column with present shim size in horizontal column.

**EXAMPLE**  
 Tappet clearance is 0.23 mm  
 Present shim size 2.70 mm  
 Shim size to be used 2.80 mm



(EXHAUST SIDE)

TAPPET SHIM SELECTION TABLE [EXHAUST]  
TAPPET SHIM NO. (12892-41C00-XXX)

MEASURED TAPPET CLEARANCE (mm)	OPTION																TAPPET SHIM SET (12800-41810)															
	230	235	240	245	250	255	260	265	270	275	280	285	290	295	300	305	310	315	320	325	330	335	340	345	350							
0.00 - 0.04					2.30	2.35	2.40	2.45	2.50	2.55	2.60	2.65	2.70	2.75	2.80	2.85	2.90	2.95	3.00	3.05	3.10	3.15	3.20	3.25	3.30							
0.05 - 0.09				2.30	2.35	2.40	2.45	2.50	2.55	2.60	2.65	2.70	2.75	2.80	2.85	2.90	2.95	3.00	3.05	3.10	3.15	3.20	3.25	3.30	3.35							
0.10 - 0.14			2.30	2.35	2.40	2.45	2.50	2.55	2.60	2.65	2.70	2.75	2.80	2.85	2.90	2.95	3.00	3.05	3.10	3.15	3.20	3.25	3.30	3.35	3.40							
0.15 - 0.19		2.30	2.35	2.40	2.45	2.50	2.55	2.60	2.65	2.70	2.75	2.80	2.85	2.90	2.95	3.00	3.05	3.10	3.15	3.20	3.25	3.30	3.35	3.40	3.45							
0.20 - 0.30																																
0.31 - 0.35	2.40	2.45	2.50	2.55	2.60	2.65	2.70	2.75	2.80	2.85	2.90	2.95	3.00	3.05	3.10	3.15	3.20	3.25	3.30	3.35	3.40	3.45	3.50	3.50								
0.36 - 0.40	2.45	2.50	2.55	2.60	2.65	2.70	2.75	2.80	2.85	2.90	2.95	3.00	3.05	3.10	3.15	3.20	3.25	3.30	3.35	3.40	3.45	3.50	3.50	3.50								
0.41 - 0.45	2.50	2.55	2.60	2.65	2.70	2.75	2.80	2.85	2.90	2.95	3.00	3.05	3.10	3.15	3.20	3.25	3.30	3.35	3.40	3.45	3.50	3.50	3.50	3.50								
0.46 - 0.50	2.55	2.60	2.65	2.70	2.75	2.80	2.85	2.90	2.95	3.00	3.05	3.10	3.15	3.20	3.25	3.30	3.35	3.40	3.45	3.50	3.50	3.50	3.50	3.50								
0.51 - 0.55	2.60	2.65	2.70	2.75	2.80	2.85	2.90	2.95	3.00	3.05	3.10	3.15	3.20	3.25	3.30	3.35	3.40	3.45	3.50	3.50	3.50	3.50	3.50	3.50								
0.56 - 0.60	2.65	2.70	2.75	2.80	2.85	2.90	2.95	3.00	3.05	3.10	3.15	3.20	3.25	3.30	3.35	3.40	3.45	3.50	3.50	3.50	3.50	3.50	3.50	3.50								
0.61 - 0.65	2.70	2.75	2.80	2.85	2.90	2.95	3.00	3.05	3.10	3.15	3.20	3.25	3.30	3.35	3.40	3.45	3.50	3.50	3.50	3.50	3.50	3.50	3.50	3.50								
0.66 - 0.70	2.75	2.80	2.85	2.90	2.95	3.00	3.05	3.10	3.15	3.20	3.25	3.30	3.35	3.40	3.45	3.50	3.50	3.50	3.50	3.50	3.50	3.50	3.50	3.50								
0.71 - 0.75	2.80	2.85	2.90	2.95	3.00	3.05	3.10	3.15	3.20	3.25	3.30	3.35	3.40	3.45	3.50	3.50	3.50	3.50	3.50	3.50	3.50	3.50	3.50	3.50								
0.76 - 0.80	2.85	2.90	2.95	3.00	3.05	3.10	3.15	3.20	3.25	3.30	3.35	3.40	3.45	3.50	3.50	3.50	3.50	3.50	3.50	3.50	3.50	3.50	3.50	3.50								
0.81 - 0.85	2.90	2.95	3.00	3.05	3.10	3.15	3.20	3.25	3.30	3.35	3.40	3.45	3.50	3.50	3.50	3.50	3.50	3.50	3.50	3.50	3.50	3.50	3.50	3.50								
0.86 - 0.90	2.95	3.00	3.05	3.10	3.15	3.20	3.25	3.30	3.35	3.40	3.45	3.50	3.50	3.50	3.50	3.50	3.50	3.50	3.50	3.50	3.50	3.50	3.50	3.50								
0.91 - 0.95	3.00	3.05	3.10	3.15	3.20	3.25	3.30	3.35	3.40	3.45	3.50	3.50	3.50	3.50	3.50	3.50	3.50	3.50	3.50	3.50	3.50	3.50	3.50	3.50								
0.96 - 1.00	3.05	3.10	3.15	3.20	3.25	3.30	3.35	3.40	3.45	3.50	3.50	3.50	3.50	3.50	3.50	3.50	3.50	3.50	3.50	3.50	3.50	3.50	3.50	3.50								
1.01 - 1.05	3.10	3.15	3.20	3.25	3.30	3.35	3.40	3.45	3.50	3.50	3.50	3.50	3.50	3.50	3.50	3.50	3.50	3.50	3.50	3.50	3.50	3.50	3.50	3.50								
1.06 - 1.10	3.15	3.20	3.25	3.30	3.35	3.40	3.45	3.50	3.50	3.50	3.50	3.50	3.50	3.50	3.50	3.50	3.50	3.50	3.50	3.50	3.50	3.50	3.50	3.50								
1.11 - 1.15	3.20	3.25	3.30	3.35	3.40	3.45	3.50	3.50	3.50	3.50	3.50	3.50	3.50	3.50	3.50	3.50	3.50	3.50	3.50	3.50	3.50	3.50	3.50	3.50								
1.16 - 1.20	3.25	3.30	3.35	3.40	3.45	3.50	3.50	3.50	3.50	3.50	3.50	3.50	3.50	3.50	3.50	3.50	3.50	3.50	3.50	3.50	3.50	3.50	3.50	3.50								
1.21 - 1.25	3.30	3.35	3.40	3.45	3.50	3.50	3.50	3.50	3.50	3.50	3.50	3.50	3.50	3.50	3.50	3.50	3.50	3.50	3.50	3.50	3.50	3.50	3.50	3.50								
1.26 - 1.30	3.35	3.40	3.45	3.50	3.50	3.50	3.50	3.50	3.50	3.50	3.50	3.50	3.50	3.50	3.50	3.50	3.50	3.50	3.50	3.50	3.50	3.50	3.50	3.50								
1.31 - 1.35	3.40	3.45	3.50	3.50	3.50	3.50	3.50	3.50	3.50	3.50	3.50	3.50	3.50	3.50	3.50	3.50	3.50	3.50	3.50	3.50	3.50	3.50	3.50	3.50								
1.36 - 1.40	3.45	3.50	3.50	3.50	3.50	3.50	3.50	3.50	3.50	3.50	3.50	3.50	3.50	3.50	3.50	3.50	3.50	3.50	3.50	3.50	3.50	3.50	3.50	3.50								
1.41 - 1.45	3.50	3.50	3.50	3.50	3.50	3.50	3.50	3.50	3.50	3.50	3.50	3.50	3.50	3.50	3.50	3.50	3.50	3.50	3.50	3.50	3.50	3.50	3.50	3.50								
1.46 - 1.50	3.50	3.50	3.50	3.50	3.50	3.50	3.50	3.50	3.50	3.50	3.50	3.50	3.50	3.50	3.50	3.50	3.50	3.50	3.50	3.50	3.50	3.50	3.50	3.50								

SPECIFIED CLEARANCE/NO ADJUSTMENT REQUIRED

HOW TO USE THIS CHART:

- I. Measure tappet clearance. "ENGINE IS COLD"
- II. Measure present shim size.
- III. Match clearance in vertical column with present shim size in horizontal column.

EXAMPLE

Tappet clearance is 0.38 mm  
Present shim size 2.90 mm  
Shim size to be used 3.05 mm

## SPARK PLUG

Inspect every 6 000 km (4 000 miles, 12 months).  
replace every 12 000 km (7 500 miles, 24 months).

### #2 (FRONT) SPARK PLUG REMOVAL

- Remove the frame side covers. (☞ 9-5)
- Remove the fuel tank. (☞ 6-3)
- Remove the right frame head cover and right radiator cover. (☞ 9-6)
- Disconnect lead wire coupler ① from ignition coil/plug cap.

#### CAUTION

Disconnect the lead wire coupler before removing the ignition coil/plug cap to avoid lead wire coupler damage.

- Remove the ignition coil/plug cap ②.

#### CAUTION

\* Do not pry up the ignition coil/plug cap with a screw driver or a bar to avoid its damage.  
\* Be careful not to drop the ignition coil/plug cap to prevent short/open circuit.

- Remove the spark plug with a spark plug wrench.
- Remove the right cylinder head cover cap ③.

#### NOTE:

“☆” indicates hook location.

- Remove the spark plug cap ④.
- Remove the spark plug with a spark plug wrench.

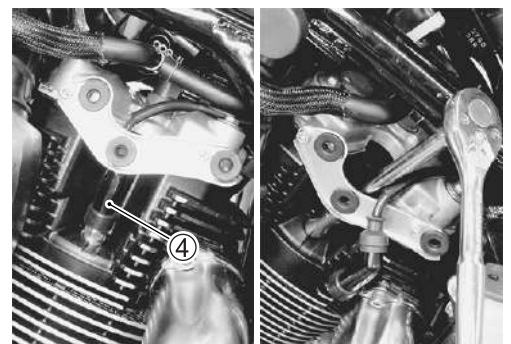
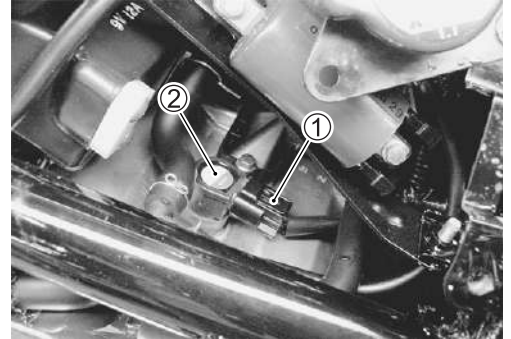

### #1 (REAR) SPARK PLUG REMOVAL

- Remove the frame side covers. (☞ 9-5)
- Remove the fuel tank. (☞ 6-3)
- Disconnect lead wire coupler ① from ignition coil/plug cap.

**CAUTION**

**Disconnect the lead wire coupler before removing the ignition coil/plug cap to avoid lead wire coupler damage.**

- Remove the ignition coil/plug cap ②.

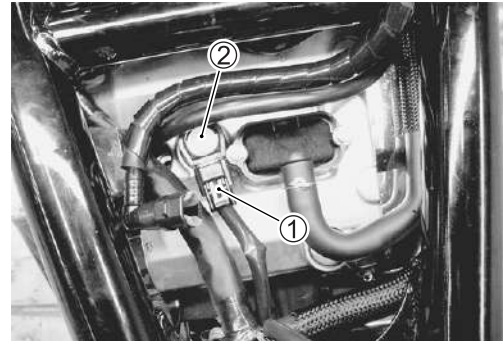

**CAUTION**

**\* Do not pry up the ignition coil/plug cap with a screw driver or a bar to avoid its damage.  
\* Be careful not to drop the ignition coil/plug cap to prevent short/open circuit.**

- Remove the spark plug with a spark plug wrench.



- Remove the left cylinder head cover cap ③.

**NOTE:**

“☆” indicates hook location.

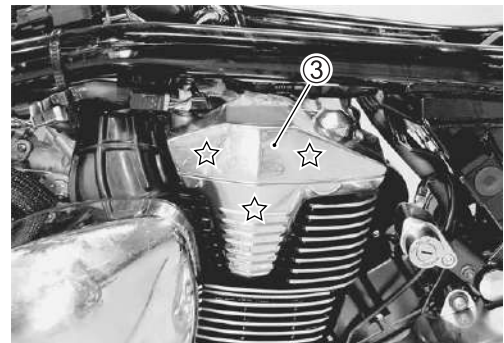

- Remove the spark plug cap ④.
- Remove the spark plug with a spark plug wrench.

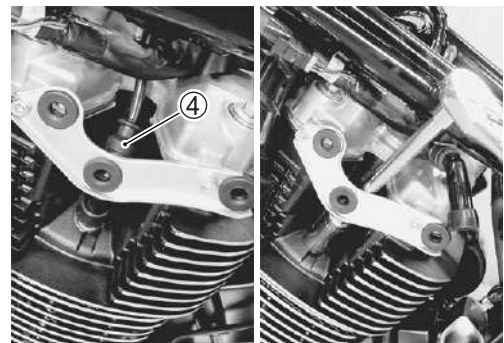

**HEAT RANGE**

- Check spark plug heat range by observing electrode color. If the electrode of the spark plug is wet appearing or dark color, replace the spark plug with hotter type one. If it is white or glazed appearing, replace the spark plug with colder type one.

	Hot type	Standard	Cold type
NGK	CR7EK	CR8EK	CR9EK
ND	U22ETR	U24ETR	U27ETR

**NOTE:**

“R” type spark plug has a resistor built into at the center electrode to prevent radio noise.

**CARBON DEPOSITS**

- Check carbon deposits on the spark plug.
- If carbon is deposited, remove it using a spark plug cleaner machine or carefully use a tool with a pointed end.

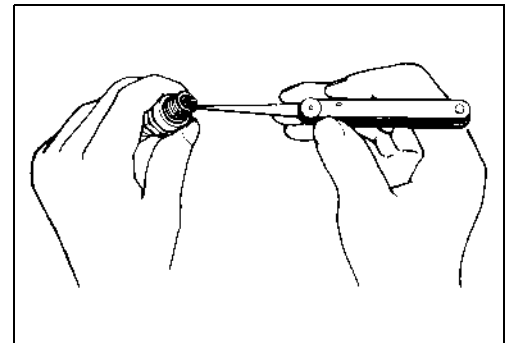

**SPARK PLUG GAP**

- Measure the spark plug gap with a thickness gauge.
- Adjust the spark plug gap if necessary.

**DATA** Spark plug gap <sup>Ⓐ</sup>  
 Standard: 0.6 – 0.7 mm (0.024 – 0.028 in)

**TOOL** 09900-20803: Thickness gauge

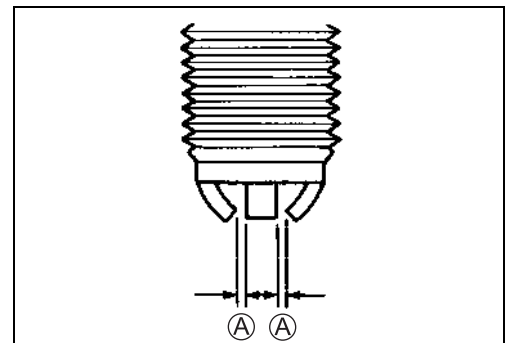

**ELECTRODE'S CONDITION**

- Check the condition of the electrode.
- If it is extremely worn or burnt, replace the spark plug. Replace the spark plug if it has a broken insulator, damaged thread, etc.

**CAUTION**

Confirm the thread size and reach when replacing the plug. If the reach is too short, carbon will be deposited on the screw portion of the plug hole and engine damage may result.

### SPARK PLUG INSTALLATION

- Screw the spark plugs into the cylinder head with fingers, and then tighten them to the specified torque.

 Spark plug: 11 N·m (1.1 kgf·m, 8.0 lb·ft)

#### CAUTION

Do not cross thread or over tighten the spark plug, or such an operation will damage the aluminum threads of the cylinder head.

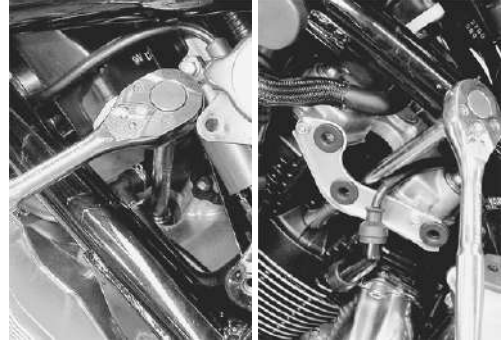

### IGNITION COIL/PLUG CAP INSTALLATION

- Install the ignition coils/plug caps and connect their lead wire couplers.

#### CAUTION

- \* Do not hit the ignition coil/plug cap with a plastic hammer when installing it.
- \* Place the ignition coil/spark plug cap so that the coupler does not touch the cylinder head cover.

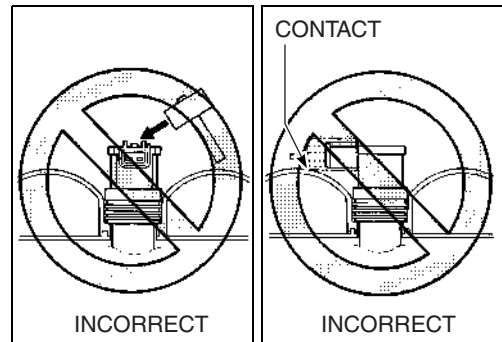

### FUEL LINE

Inspect every 6 000 km (4 000 miles, 12 months).

- Inspect the fuel feed hose ① for damage and fuel leakage. If any defects are found, the fuel feed hose must be replaced.

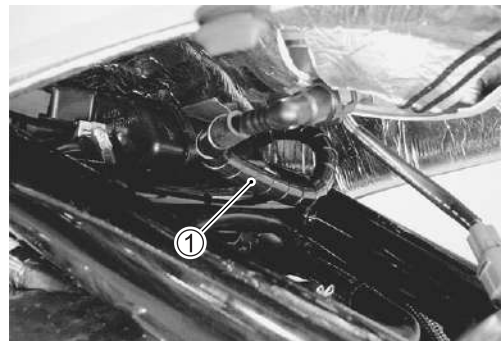

### EVAPORATIVE EMISSION CONTROL SYSTEM (E-33 ONLY)

Inspect every 12 000 km (7 500 miles, 24 months).

Inspect the evaporative emission control system periodically.



## ENGINE OIL AND OIL FILTER

### (ENGINE OIL)

Replace initially at 1 000 km (600 miles, 2 months) and every 6 000 km (4 000 miles, 12 months) thereafter.

### (OIL FILTER)

Replace initially at 1 000 km (600 miles, 2 months) and every 18 000 km (11 000 miles, 36 months) thereafter.

Oil should be changed while the engine is warm. Oil filter replacement at the above intervals, should be done together with the engine oil change.

### ENGINE OIL REPLACEMENT

- Keep the motorcycle upright.
- Place an oil pan below the engine, and drain oil by removing the oil drain plugs ① and filler cap ②.

#### Motorcycle on the upright position

- Tighten the drain plugs ① to the specified torque, and pour fresh oil through the oil filler. The engine will hold about 3.4 L (3.6/3.0 US/Imp qt) of oil. Use of API SF/SG or SH/SJ with JASO MA.
- Tighten the filler cap ②.

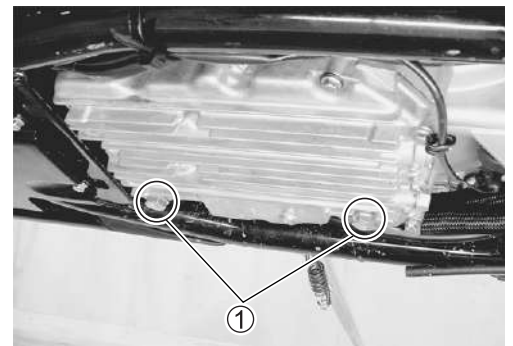

#### Oil drain plug: 23 N·m (2.3 kgf·m, 16.5 lb·ft)

#### NOTE:

Keep the motorcycle upright while pouring engine oil.

#### Motorcycle on the side-stand position

- Tighten the drain plugs ①.
- Pour fresh oil 3.0 L.
- Tighten the filler cap ②.
- Start up the engine and allow it to run few minutes at idling speed.
- Remove the filler cap ②.
- Pour fresh oil 0.4 L.
- Tighten the filler cap ②.



#### Oil level inspection

- Start up the engine and allow it to run about 15 minutes at idling speed.
- Keep the motorcycle upright.
- Turn off the engine and wait about three minutes, then check the oil level by removing the filler cap ②. If the level is below mark “L”, add oil to “F” level. (do not screw the filler cap.) If the level is above mark “F”, drain oil to “F” level.

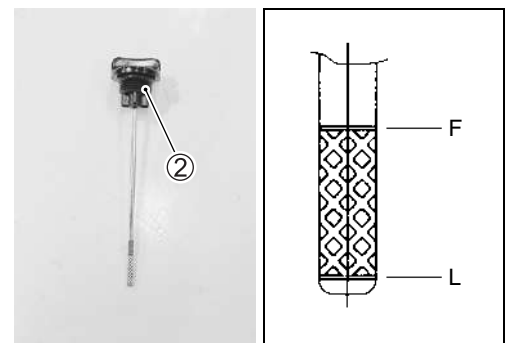

**OIL FILTER REPLACEMENT**

- Drain the engine oil as described in the engine oil replacement procedure.
- Remove the oil filter ① with the special tool.

**TOOL 09915-40610: Oil filter wrench**

- Apply engine oil lightly to the gasket of the new oil filter before installation.

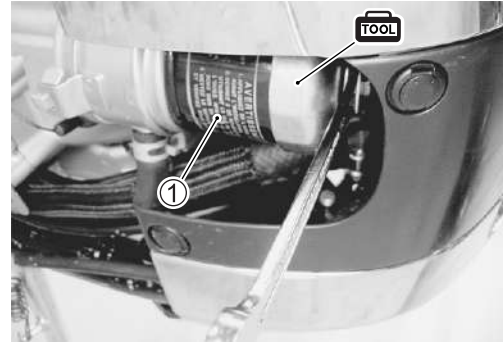

- Install the new oil filter. Turn it by hand until you feel that the oil filter gasket contacts the oil filter mounting surface. Then, tighten the oil filter two full turns with the special tool.

**NOTE:**

To properly tighten the oil filter, use the special tool. Never tighten the oil filter by hand.

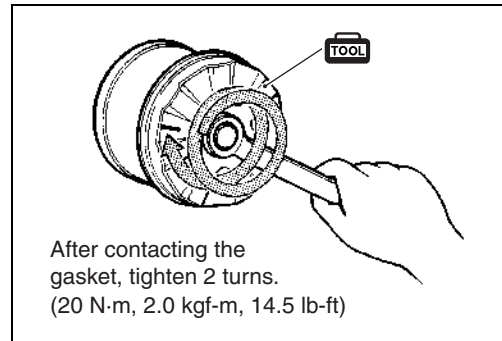
**Oil filter: 20 N-m (2.0 kgf-m, 14.5 lb-ft)**

- Add new engine oil and check the oil level is as described in the engine oil replacement procedure.

**DATA NECESSARY AMOUNT OF ENGINE OIL:**

Oil change	: 3.4 L (3.6/3.0 US/Imp qt)
Oil and filter change	: 3.6 L (3.8/3.2 US/Imp qt)
Engine overhaul	: 4.7 L (5.0/4.1 US/Imp qt)

**CAUTION**

**ONLY USE A GENUINE SUZUKI MOTORCYCLE OIL FILTER.** Other manufacturer's oil filters may differ in thread specifications (thread diameter and pitch), filtering performance and durability which may lead to engine damage or oil leaks. Also, do not use a genuine Suzuki automobile oil filter on this motorcycle.

## FINAL GEAR OIL

Replace initially at 1 000 km (600 miles, 2 months) and inspect every 12 000 km (7 500 miles, 24 months) thereafter.

- Keep the motorcycle upright.
- Place an oil pan under the final gear case.
- Remove the filler cap ① and drain plug ② to drain oil.
- Tighten the drain plug ② to the specified torque. Pour the specified oil (SAE 90 hypoid gear oil with GL-5 under API classification) through the filler hole until the oil level reaches the filler hole.
- Refit the filler cap ①.

 Final gear oil drain plug: 23 N·m (2.3 kgf·m, 16.5 lb·ft)

 Final gear oil: 200 – 220 ml  
(6.8/7.0 – 7.4/7.7 US/Imp oz)



## THROTTLE CABLE PLAY

Inspect initially at 1 000 km (600 miles, 2 months) and every 6 000 km (4 000 miles, 12 months) thereafter.

Adjust the throttle cable play ① as follows.

- Loosen the lock nut ② of the throttle pulling cable ①.
- Turn the adjuster ③ in or out until the throttle cable play (at the throttle grip) ① is between 2.0 – 4.0 mm (0.08 – 0.16 in).
- Tighten the lock nut ② while holding the adjuster ③.

 Throttle cable play ①: 2.0 – 4.0 mm (0.08 – 0.16 in)

### WARNING

After the adjustment is completed, check that handlebar movement does not raise the engine idle speed and that the throttle grip returns smoothly and automatically.

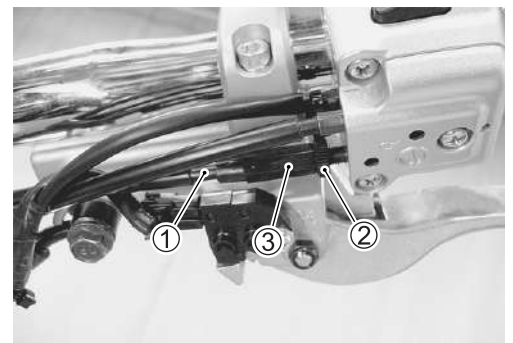
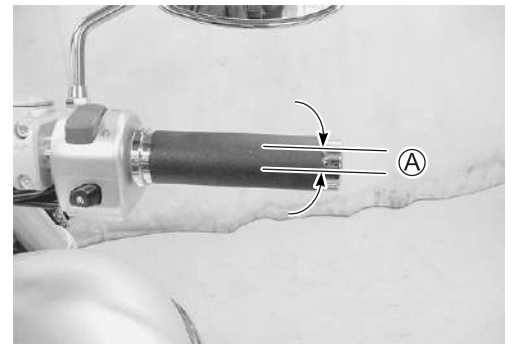

## PAIR (AIR SUPPLY) SYSTEM

Inspect every 12 000 km (7 500 miles, 24 months).

Inspect the PAIR (air supply) system periodically. (📄 12-6)



## THROTTLE VALVE SYNCHRONIZATION

Inspect initially at 1 000 km (600 miles, 2 months) (E-33 only) and every 12 000 km (7 500 miles, 24 months).

Inspect the throttle valve synchronization periodically. (☞ 6-23)

## COOLING SYSTEM

Inspect every 6 000 km (4 000 miles, 12 months).  
Replace engine coolant every 2 years.

### ENGINE COOLANT LEVEL CHECK

- Keep the motorcycle upright.
- Check the engine coolant level by observing the full and lower lines on the engine coolant reservoir.
  - Ⓐ Full line    Ⓑ Lower line
- If the level is below the lower line, remove the fuel tank (☞ 6-3), left frame head cover and left radiator cover (☞ 9-6), and add engine coolant to the full line from the engine coolant reservoir filler.

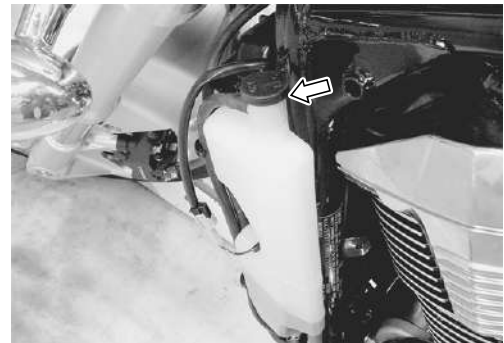
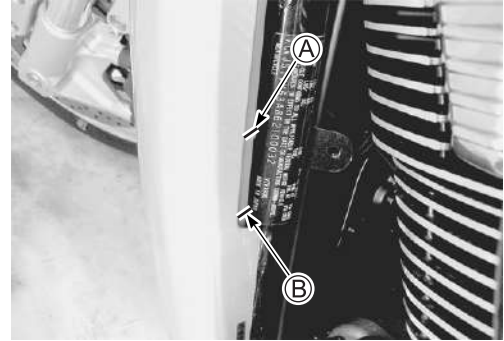

### ENGINE COOLANT CHANGE

- Remove the fuel tank. (☞ 6-3)
- Remove the left and right frame head covers, radiator covers and radiator bottom cover. (☞ 9-6)
- Remove the radiator cap ①.

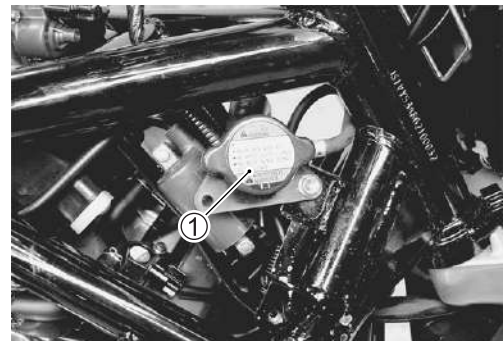

- Drain engine coolant by disconnecting the radiator hose ② from the radiator.

**⚠ WARNING**

- \* Do not open the radiator cap when the engine is hot, as you may be injured by escaping hot liquid or vapor.
- \* Engine coolant may be harmful if swallowed or if it comes in contact with skin or eyes. If engine coolant gets into the eyes or in contact with the skin, flush thoroughly with plenty of water. If swallowed, induce vomiting and call physician immediately!



- Flush the radiator with fresh water if necessary.
- Connect the radiator hose ② securely.
- Pour the specified engine coolant up to the radiator inlet.

**LLC Engine coolant capacity (excluding reservoir):**  
**2 450 ml (2.6/2.2 US/Imp qt)**

- Bleed the air from the engine coolant circuit in the following procedure. (☞ below)

**ENGINE COOLANT INFORMATION (☞ 8-2)**

**AIR BLEEDING THE COOLING CIRCUIT**

- Remove the fuel tank. (☞ 6-3)
- Remove the right frame head cover. (☞ 9-6)
- Add engine coolant up to the radiator inlet.
- Support the motorcycle upright.
- Slowly swing the motorcycle, right and left, to bleed the air trapped in the cooling circuit.
- Add engine coolant up to the radiator inlet.
- Start up the engine and bleed air from the radiator inlet completely.
- Add engine coolant up to the radiator inlet.
- Repeat the above procedure until bleed no air from the radiator inlet.
- Close the radiator cap securely.
- After warming up and cooling down the engine several times, add the engine coolant up to the full level of the reservoir.



**CAUTION**

**Repeat the above procedure several times and make sure that the radiator is filled with engine coolant up to the reservoir full level.**

**LLC Engine coolant capacity**  
**Reservoir side: 250 ml (0.3/0.2 US/Imp qt)**  
**Engine side: 2 450 ml (2.6/2.2 US/Imp qt)**

**RADIATOR HOSES**

- Remove the fuel tank. (☞ 6-3)
- Remove the frame head covers, radiator covers and radiator bottom cover. (☞ 9-6)
- Check to see the radiator hoses for crack, damage or engine coolant leakage.
- If any defects are found, replace the radiator hoses with new ones.

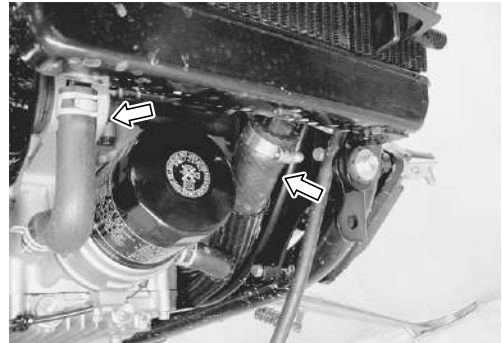
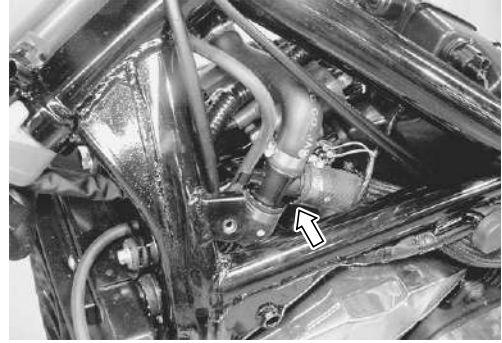
**CLUTCH CABLE PLAY**

Inspect every 6 000 km (4 000 miles, 12 months).

- Loosen the lock nut ①.
- Turn in the adjuster ② all the way into the clutch lever assembly.
- Remove the secondary gear case cover ③.

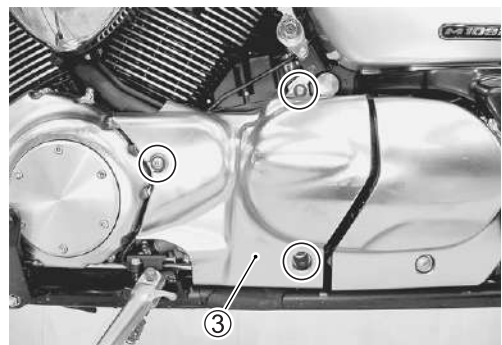
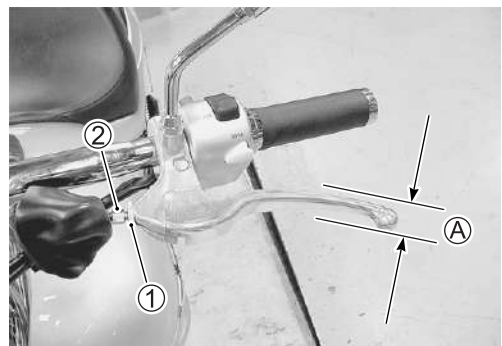

- Loosen the lock nut ④, and turn the cable adjuster ⑤ to obtain 10 – 15 mm (0.4 – 0.6 in) of free play A at the clutch lever end.
- Tighten the lock nut ④.

**DATA** Clutch lever play A: 10 – 15 mm (0.4 – 0.6 in)

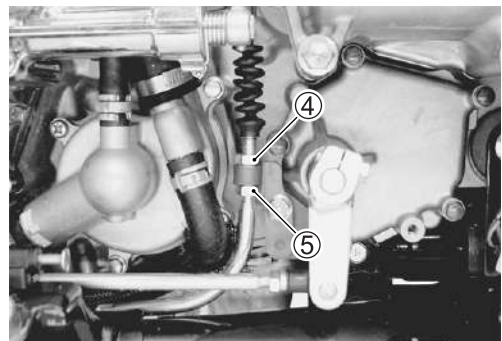

## BRAKE

### (BRAKE)

Inspect initially at 1 000 km (600 miles, 2 months) and every 6 000 km (4 000 miles, 12 months) thereafter.

### (BRAKE HOSE AND BRAKE FLUID)

Inspect every 6 000 km (4 000 miles, 12 months).  
Replace hoses every 4 years. Replace fluid every 2 years.

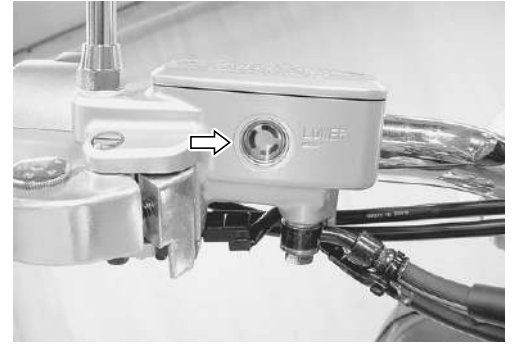

### BRAKE FLUID LEVEL CHECK

- Keep the motorcycle upright and place the handlebars straight.
- Check the brake fluid level relative to the lower limit lines on the front and rear brake fluid reservoirs.
- When the level is below the lower limit line, replenish with brake fluid that meets the following specification.



**Specification and classification: DOT 4**

### **⚠ WARNING**

- \* The brake system of this motorcycle is filled with a glycol-based brake fluid. Do not use or mix different types of fluid such as silicone-based and petroleum-based fluids. Do not use any brake fluid taken from old, used or unsealed containers. Never re-use brake fluid left over from the last servicing or stored for a long period of time.
- \* Brake fluid, if it leaks, will interfere with safe running and immediately discolor painted surfaces. Check the brake hoses and hose joints for cracks and fluid leakage before riding.

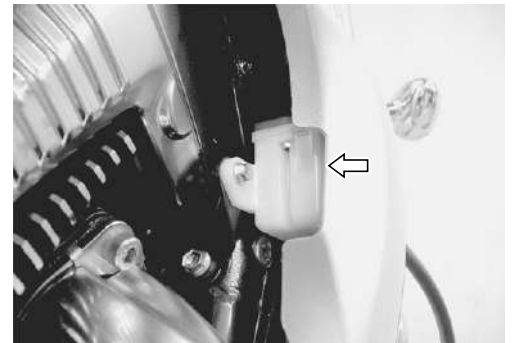

## BRAKE PADS

### Front brake

The extent of brake pad wear can be checked by observing the grooved limit line (A) on the pad. When the wear exceeds the grooved limit line, replace the pads with the new ones.

( 9-52)

#### CAUTION

**Replace the brake pads as a set, otherwise braking performance will be adversely affected.**

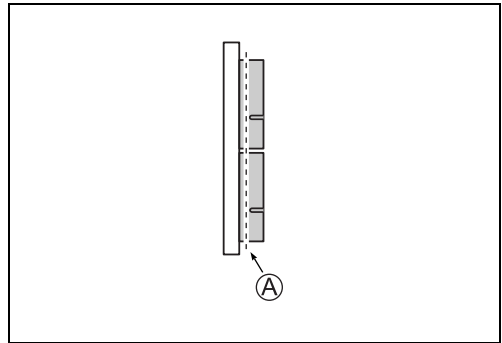
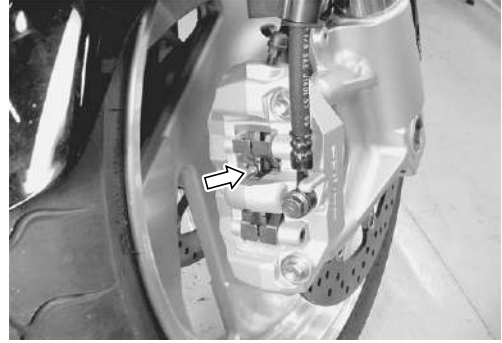

### Rear brake

The extent of brake pad wear can be checked by observing the grooved limit line (A) on the pad. When the wear exceeds the grooved limit line, replace the pads with the new ones.

( 9-63)

#### CAUTION

**Replace the brake pads as a set, otherwise braking performance will be adversely affected.**

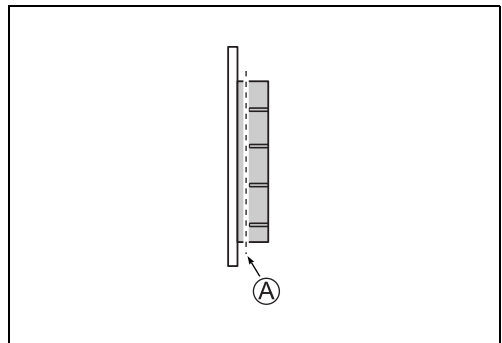
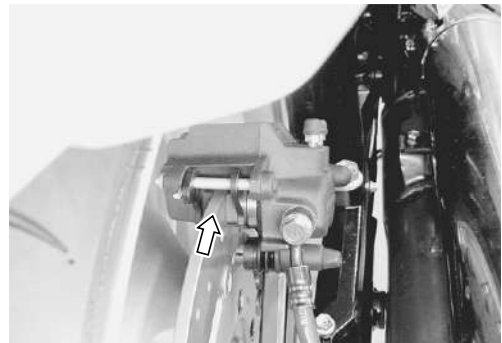

**BRAKE PEDAL HEIGHT**

- Loosen the lock nut ①.
- Turn the push rod ② until the brake pedal height becomes 25 – 35 mm (1.0 – 1.4 in) Ⓐ below the top of the footrest.
- Tighten the lock nut ① securely.

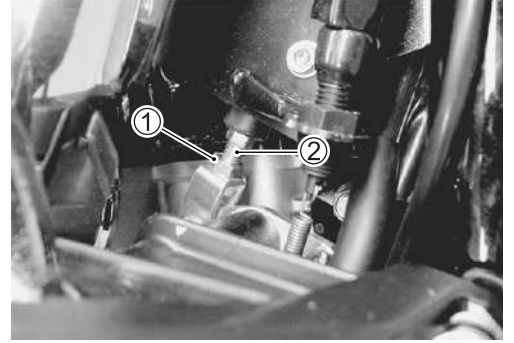

 **Rear brake master cylinder rod lock nut:**  
18 N·m (1.8 kgf-m, 13.0 lb-ft)

**DATA** **Brake pedal height Ⓐ:**  
Standard: 25 – 35 mm (1.0 – 1.4 in)

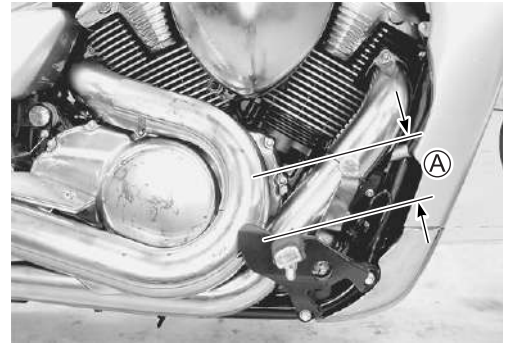
**BRAKE LIGHT SWITCH**

- Adjust the rear brake light switch so that the brake light will come on just before pressure is felt when the brake pedal is depressed.

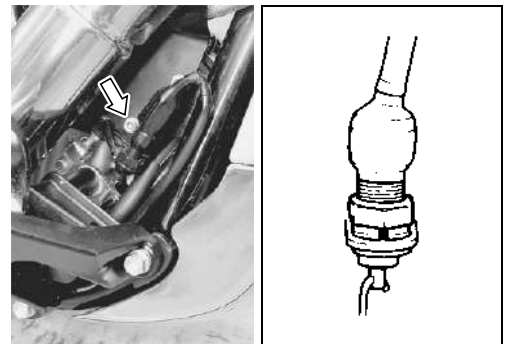



### AIR BLEEDING FROM BRAKE FLUID CIRCUIT

Air trapped in the brake fluid circuit acts like a cushion to absorb a large proportion of the pressure developed by the master cylinder and thus interferes with the full braking performance of the brake caliper. The presence of air is indicated by “sponginess” of the brake lever and also by lack of braking force. Considering the danger to which such trapped air exposes the machine and rider, it is essential that after remounting the brake and restoring the brake system to the normal condition, the brake fluid circuit be purged of air in the following manner:

#### FRONT BRAKE

- Fill the master cylinder reservoir to the top of the inspection window. Replace the reservoir cap to prevent dirt from entering.
- Attach a hose to the air bleeder valve and insert the free end of the hose into a receptacle.
- Squeeze and release the brake lever several times in rapid succession and squeeze the lever fully without releasing it. Loosen the air bleeder valve by turning it a quarter of a turn so that the brake fluid runs into the receptacle. This will remove the tension of the brake lever causing it to touch the handlebar grip. Then, close the air bleeder valve, pump and squeeze the lever, and open the valve. Repeat this process until fluid flowing into the receptacle no longer contains air bubbles.

#### NOTE:

*While bleeding the brake system, replenish the brake fluid in the reservoir as necessary. Make sure that there is always some fluid visible in the reservoir.*

- Close the air bleeder valve and disconnect the hose. Fill the reservoir with brake fluid to the top of the inspection window.

 **Air bleeder valve: 7.5 N·m (0.75 kgf·m, 5.5 lb·ft)**

#### CAUTION

**Handle brake fluid with care: the fluid reacts chemically with paint, plastics, rubber materials, etc.**

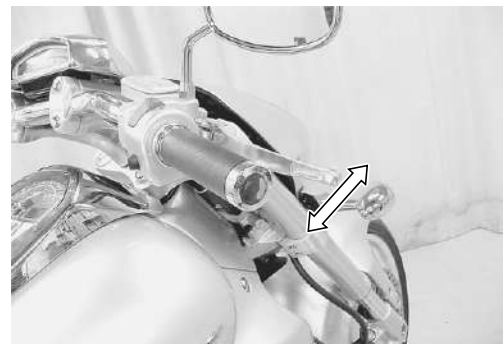
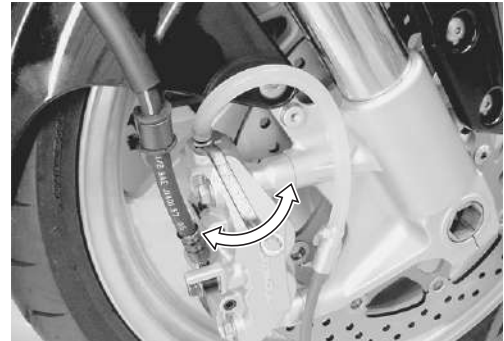

## REAR BRAKE

- Bleed air from the rear brake system in the same manner as front brake.

 **Air bleeder valve: 7.5 N·m (0.75 kgf·m, 5.5 lb·ft)**

### NOTE:

*The only of between operation from bleeding the front brake is that the rear master cylinder is actuated by a pedal.*

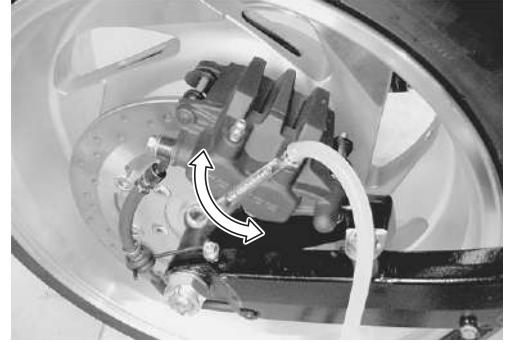

## TIRES

Inspect every 6 000 km (4 000 miles, 12 months).

### TIRE TREAD CONDITION

Operating the motorcycle with excessively worn tires will decrease riding stability and consequently invite a dangerous situation. It is highly recommended to replace a tire when the remaining depth of tire tread reaches the following specification.

 **09900-20805: Tire depth gauge**

 **Tire tread depth:**

**Service Limit: FRONT : 1.6 mm (0.06 in)**

**REAR : 2.0 mm (0.08 in)**

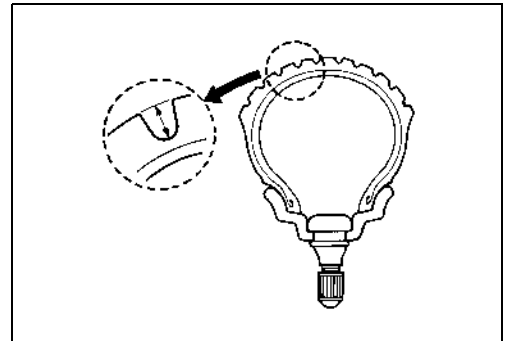



## TIRE PRESSURE

If the tire pressure is too high or too low, steering will be adversely affected and tire wear will increase. Therefore, maintain the correct tire pressure for good roadability and a longer tire life. Cold inflation tire pressure is as follows.

### **DATA** Cold inflation tire pressure

**Solo riding: Front: 250 kPa (2.50 kgf/cm<sup>2</sup>, 36 psi)**  
**Rear: 290 kPa (2.90 kgf/cm<sup>2</sup>, 42 psi)**  
**Dual riding: Front: 250 kPa (2.50 kgf/cm<sup>2</sup>, 36 psi)**  
**Rear: 290 kPa (2.90 kgf/cm<sup>2</sup>, 42 psi)**

### **CAUTION**

The standard tire fitted on this motorcycle is 130/70 R18 M/C 63 V for the front and 240/40 R18 M/C 79 V for the rear. The use of tires other than those specified may cause instability. It is highly recommended to use the specified tires.

### **DATA** TIRE TYPE

**DUNLOP (Front: D221FA, Rear: D221)**

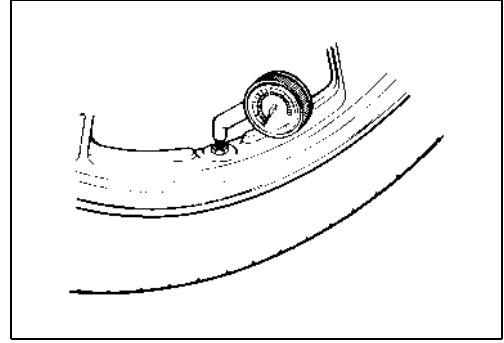

## STEERING

**Inspect initially at 1 000 km (600 miles, 2 months) and every 12 000 km (7 500 miles, 24 months) thereafter.**

The steering should be adjusted properly for smooth turning of the handlebars and safe operation. Overtighten steering prevents smooth turning of the handlebars and too loose steering will cause poor stability. Check that there is no play in the front fork. Support the motorcycle so that the front wheel is off the ground. With the wheel facing straight ahead, grasp the lower fork tubes near the axle and pull forward. If play is found, readjust the steering. (☞ 9-27)



## FRONT FORK

**Inspect every 12 000 km (7 500 miles, 24 months).**

Inspect the front fork for oil leakage, scoring or scratches on the outer surface of the inner tubes. Replace any defective parts, if necessary. (☞ 9-15)



## REAR SUSPENSION

**Inspect every 12 000 km (7 500 miles, 24 months).**

- Remove the under cover. (☞ 9-41)

Inspect the rear shock absorber for oil leakage and check that there is no play in the swingarm. Replace any defective parts if necessary. (☞ 9-41)

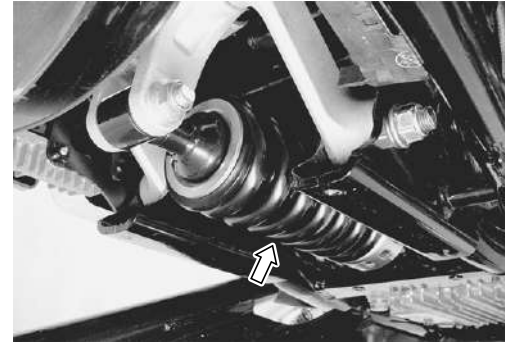

## CHASSIS BOLTS AND NUTS

**Tighten initially at 1 000 km (600 miles, 2 months) and every 6 000 km (4 000 miles, 12 months) thereafter.**

Check that all chassis bolts and nuts are tightened to their specified torque. (Refer to page 2-30 for the locations of the following nuts and bolts on the motorcycle.)

Item	N·m	kgf·m	lb·ft
① Steering stem head nut	90	9.0	65.0
② Front fork upper clamp bolt	23	2.3	16.5
③ Front fork lower clamp bolt	23	2.3	16.5
④ Front fork cap bolt	23	2.3	16.5
⑤ Front axle	100	10.0	72.5
⑥ Front axle pinch bolt	23	2.3	16.5
⑦ Handlebar clamp bolt	23	2.3	16.5
⑧ Front brake master cylinder mounting bolt	10	1.0	7.0
⑨ Front brake caliper mounting bolt	39	3.9	28.0
⑩ Brake hose union bolt (Front & Rear)	23	2.3	16.5
⑪ Air bleeder valve (Front & Rear)	7.5	0.75	5.5
⑫ Brake disc bolt (Front & Rear)	23	2.3	16.5
⑬ Rear brake caliper mounting bolt	39	3.9	28.0
⑭ Rear brake master cylinder mounting bolt	10	1.0	7.0
⑮ Rear brake master cylinder rod lock nut	18	1.8	13.0
⑯ Front footrest bracket mounting bolt (Right)	60	6.0	43.5
⑰ Front footrest bracket mounting bolt (Left)	50	5.0	36.0
⑱ Swingarm pivot shaft	100	10.0	72.5
⑲ Rear shock absorber mounting bolt/nut (Front & Rear)	45	4.5	32.5
⑳ Cushion rod nut	110	11.0	79.5
㉑ Cushion lever mounting nut (Upper)	110	11.0	79.5
㉒ Cushion lever mounting nut (Lower)	85	8.5	61.5
㉓ Rear axle nut	For E-03, 28, 33	100	10.0
	For others	110	11.0
㉔ Handlebar holder nut	85	8.5	61.5
㉕ Rear brake caliper bracket mounting bolt	80	8.0	58.0

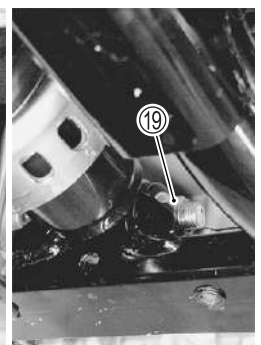
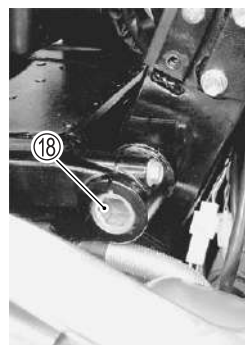
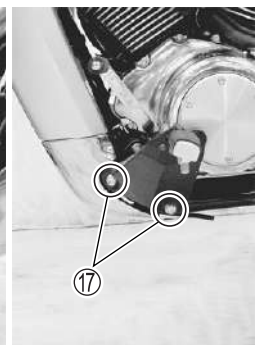
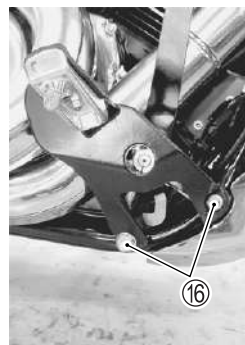
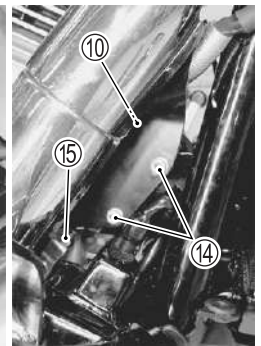
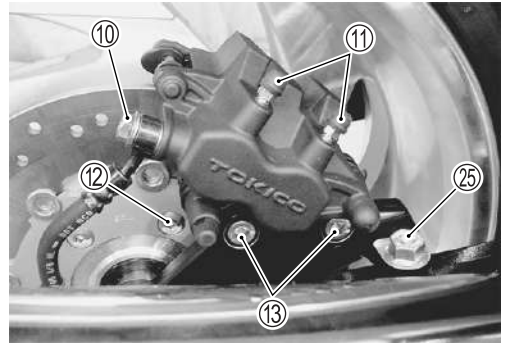
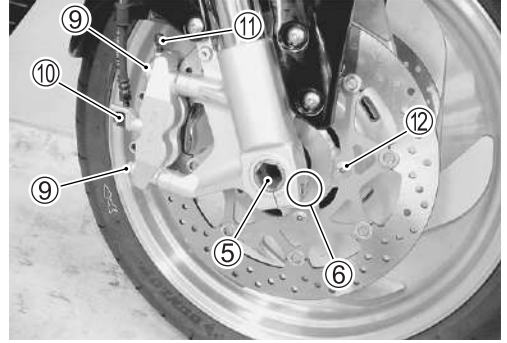
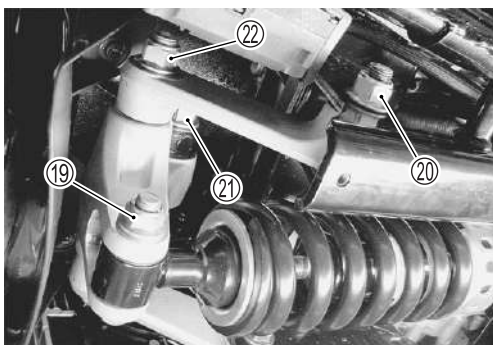
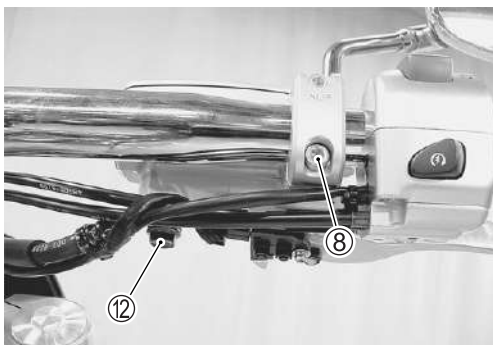
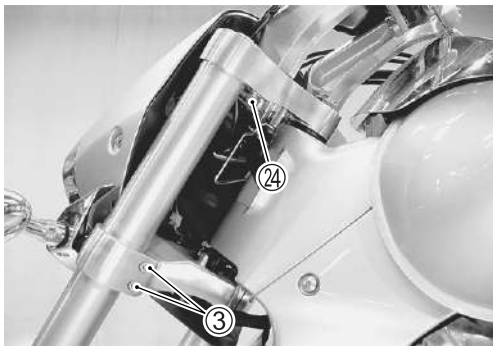
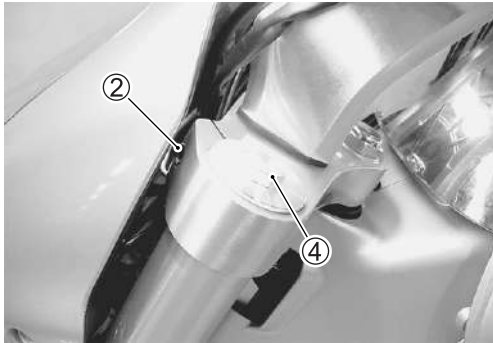
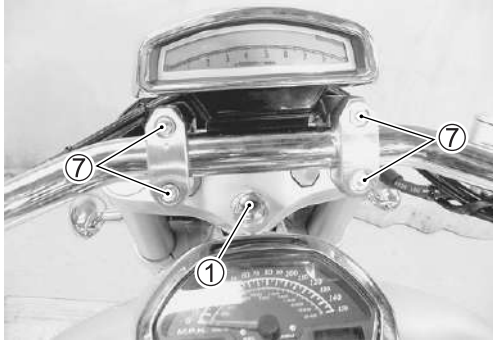

## COMPRESSION PRESSURE CHECK

The compression pressure reading of a cylinder is a good indicator of its internal condition.

The decision to overhaul the cylinder is often based on the results of a compression test. Periodic maintenance records kept at your dealership should include compression readings for each maintenance service.

### COMPRESSION PRESSURE SPECIFICATION

Standard	Limit	Difference
1 100 – 1 500 kPa (11.0 – 15.0 kgf/cm <sup>2</sup> , 156 – 213 psi)	800 kPa (8.0 kgf/cm <sup>2</sup> , 114 psi)	200 kPa (2.0 kgf/cm <sup>2</sup> , 28 psi)

### Low compression pressure can indicate any of the following conditions:

- \* Excessively worn cylinder walls
- \* Worn piston or piston rings
- \* Piston rings stuck in grooves
- \* Poor valve seating
- \* Ruptured or otherwise defective cylinder head gasket

### Overhaul the engine in the following cases:

- \* Compression pressure in one of the cylinders is 800 kPa (8.0 kgf/cm<sup>2</sup>, 114 psi) and less.
- \* The difference in compression pressure between any two cylinders is 200 kPa (2.0 kgf/cm<sup>2</sup>, 28 psi) and more.
- \* All compression pressure readings are below 1 100 kPa (11.0 kgf/cm<sup>2</sup>, 156 psi) even when they measure 800 kPa (8.0 kgf/cm<sup>2</sup>, 114 psi) and more.

## COMPRESSION TEST PROCEDURE

### NOTE:

- \* Before testing the engine for compression pressure, make sure that the cylinder head nuts are tightened to the specified torque values and the valves are properly adjusted.
- \* Have the engine warmed up before testing.
- \* Make sure that the battery is fully-charged.

Remove the related parts and test the compression pressure in the following manner.

- Remove the outside spark plugs (#1 & #2). (☞ 2-13 and -14)
- Install the compression gauge and adaptor in the spark plug hole. Make sure that the connection is tight.
- Keep the throttle grip in the fully opened position.
- Press the starter button and crank the engine for a few seconds. Record the maximum gauge reading as the cylinder compression.
- Repeat this procedure with the other cylinder.

 **09915-64512: Compression gauge set**  
**09913-10750: Adaptor**

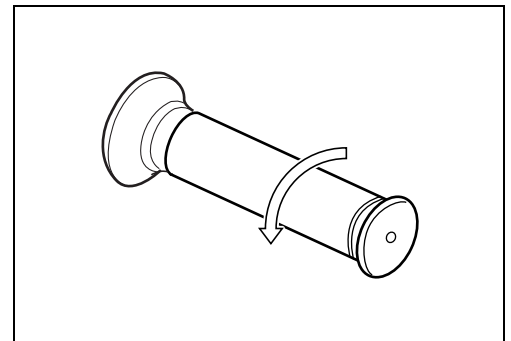

## OIL PRESSURE CHECK

Check the engine oil pressure periodically. This will give a good indication of the condition of the moving parts.

### OIL PRESSURE SPECIFICATION

**400 – 700 kPa (4.0 – 7.0 kgf/cm<sup>2</sup>, 57 – 100 psi) at 3 000 r/min, Oil temp. at 60 °C (140 °F)**

If the oil pressure is lower or higher than the specification, the following causes may be considered.

### LOW OIL PRESSURE

- \* Clogged oil filter
- \* Oil leakage from the oil passage
- \* Damaged O-ring
- \* Defective oil pump
- \* Combination of the above items

### HIGH OIL PRESSURE



- \* Engine oil viscosity is too high
- \* Clogged oil passage
- \* Combination of the above items

### OIL PRESSURE TEST PROCEDURE

Start the engine and check if the oil pressure indicator light is turned on. If the light stays on, check the oil pressure indicator light circuit. If the circuit is OK, check the oil pressure in the following manner.

- Remove the boot ① and oil pressure switch lead wire ②.
- Remove the oil pressure switch ③.
- Install the oil pressure gauge and adaptor into the oil gallery.
- Install the oil pressure switch ④ into the adaptor.
- Warm up the engine as follows:
  - Summer : 5 min at idle r/min
  - Winter : 8 min at idle r/min
- After warming up, increase the engine speed to 3 000 r/min (observe the tachometer), and read the oil pressure gauge.

-  **09915-74521: Oil pressure gauge hose**
- 09915-17410: Oil pressure gauge attachment**
- 09915-77331: Meter (for high pressure)**

- Install the oil pressure switch. ( 3-86)
- Check engine oil. ( 2-17)

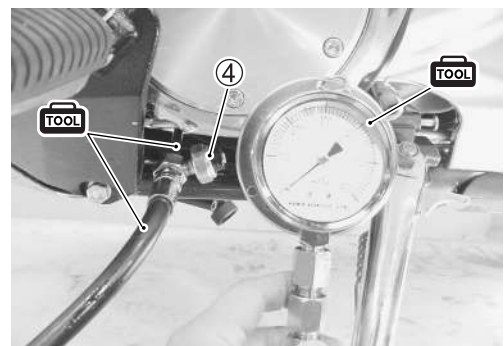
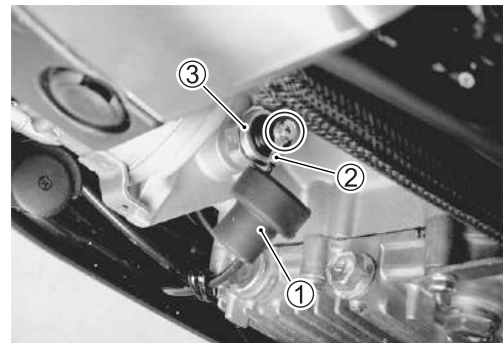

## SDS CHECK

Using SDS, take the sample of data from the new motorcycle and at the time of periodic maintenance at your dealership.

Save the data in the computer or by printing and filing the hard copies. The saved or filed data are useful for troubleshooting as they can be compared periodically with changes over time or failure conditions of the motorcycle.

For example, when a motorcycle is brought in for service but the troubleshooting is difficult, comparison with the normal data that have been saved or filed can allow the specific engine failure to be determined.

- Remove the left frame side cover. (☞ 9-5)
- Set up the SDS tool. (☞ 5-25)



**09904-41010: SDS set tool**

**99565-01010-007: CD-ROM Ver. 7**

### NOTE:

\* Before taking the sample of data, check and clear the Past DTC. (☞ 5-26)

\* A number of different data under a fixed condition as shown below should be saved or filed as sample.

### SAMPLE:

#### Data sampled from cold starting through warm-up

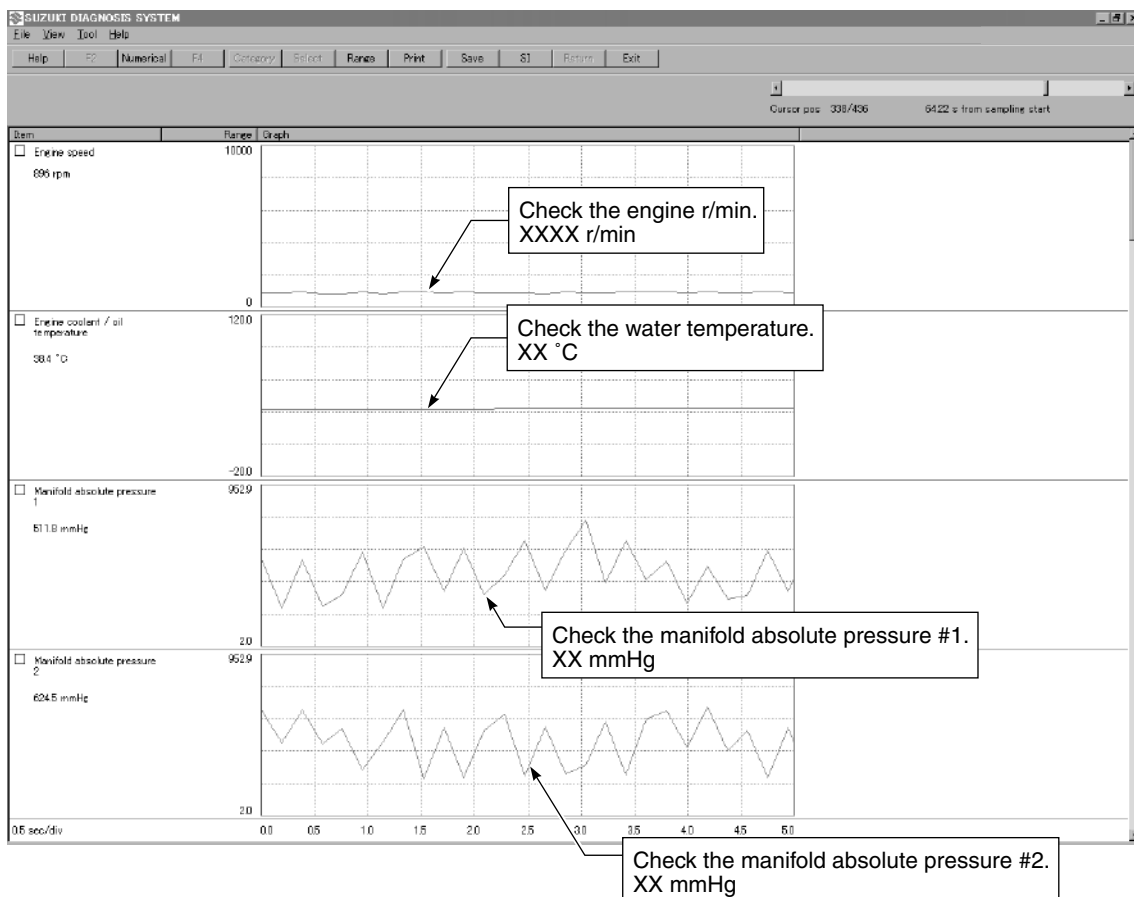

## Data at 3 000 r/min under no load

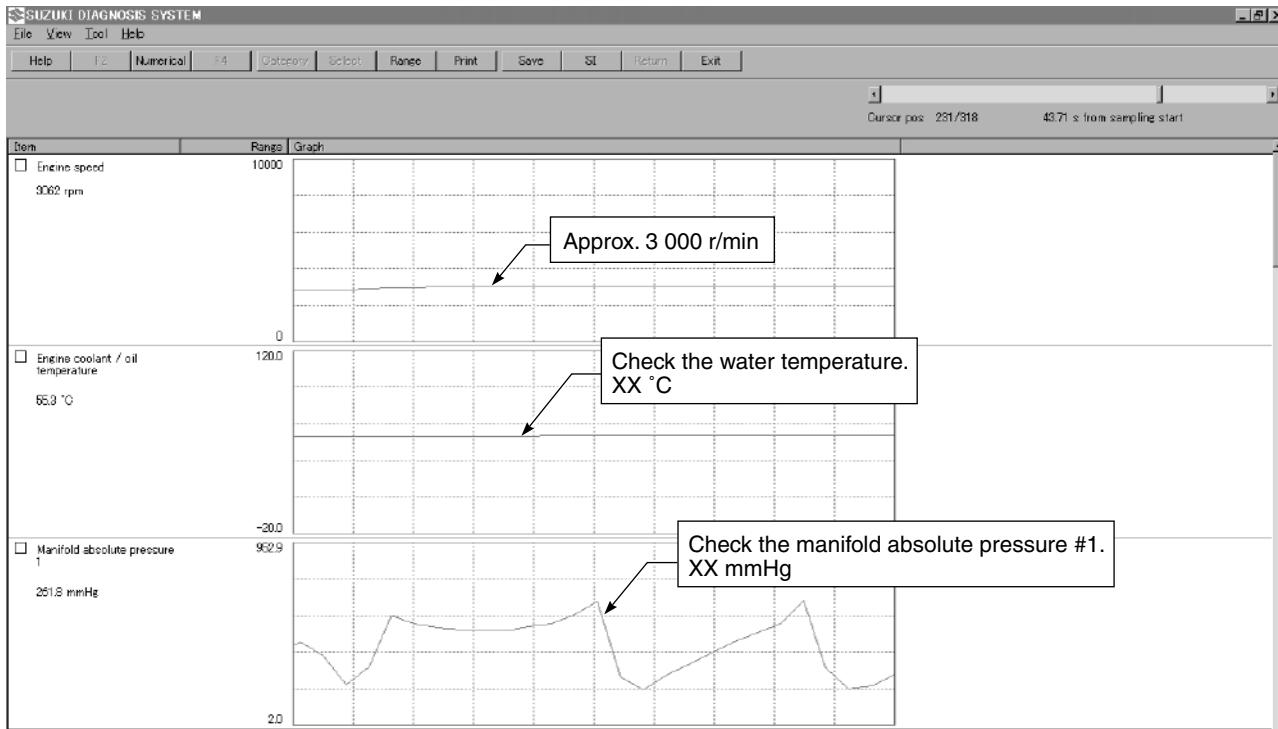

## Data at the time of racing

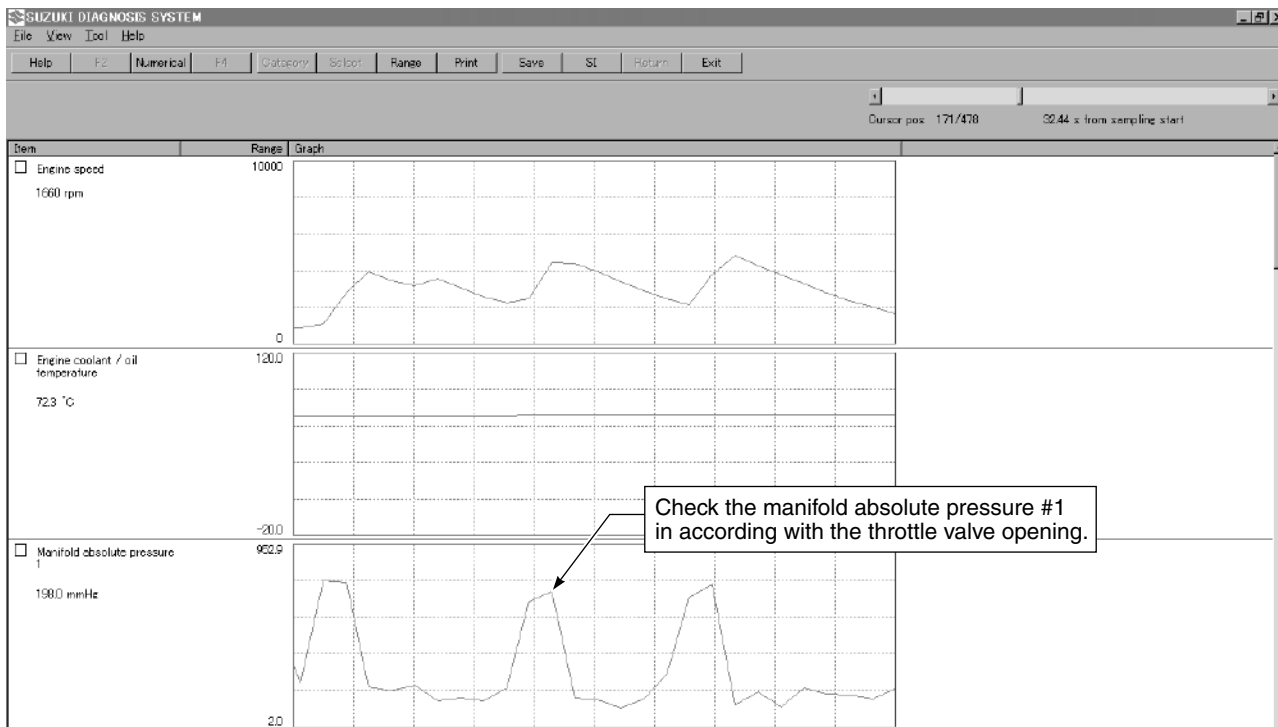



### Data of intake negative pressure during idling (100 °C)

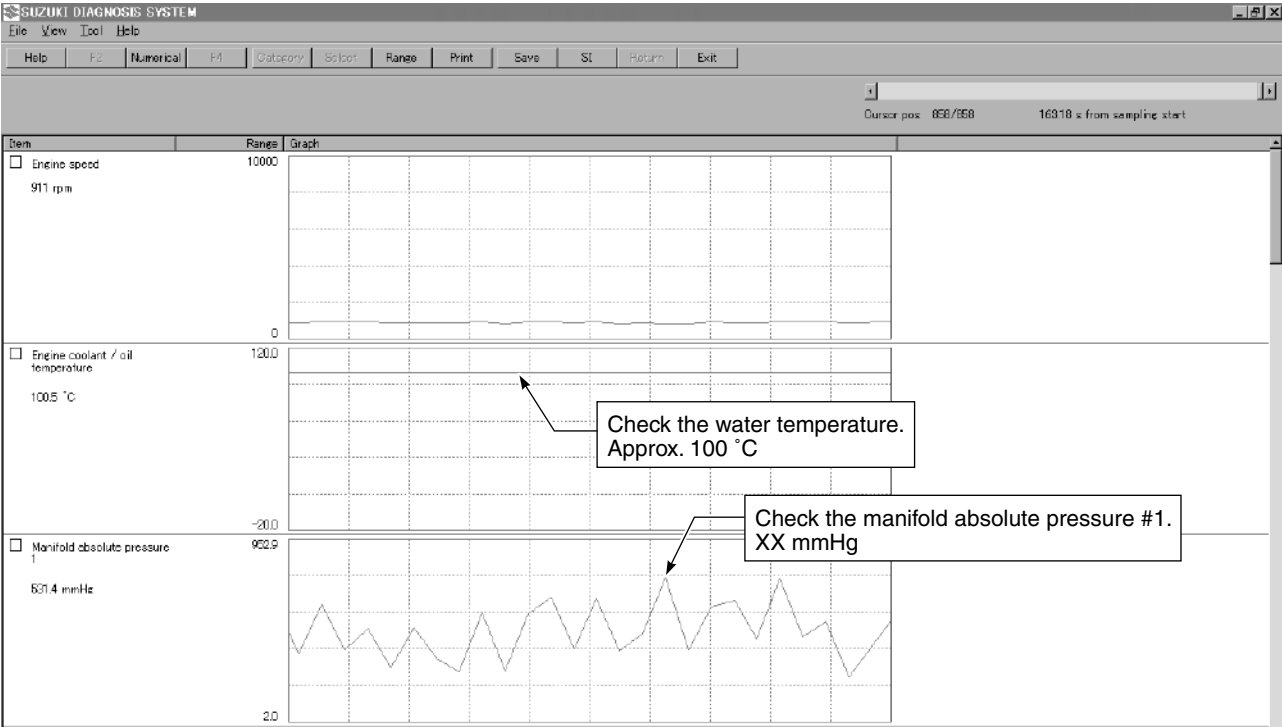

### Data of manifold absolute pressure operation at the time of starting

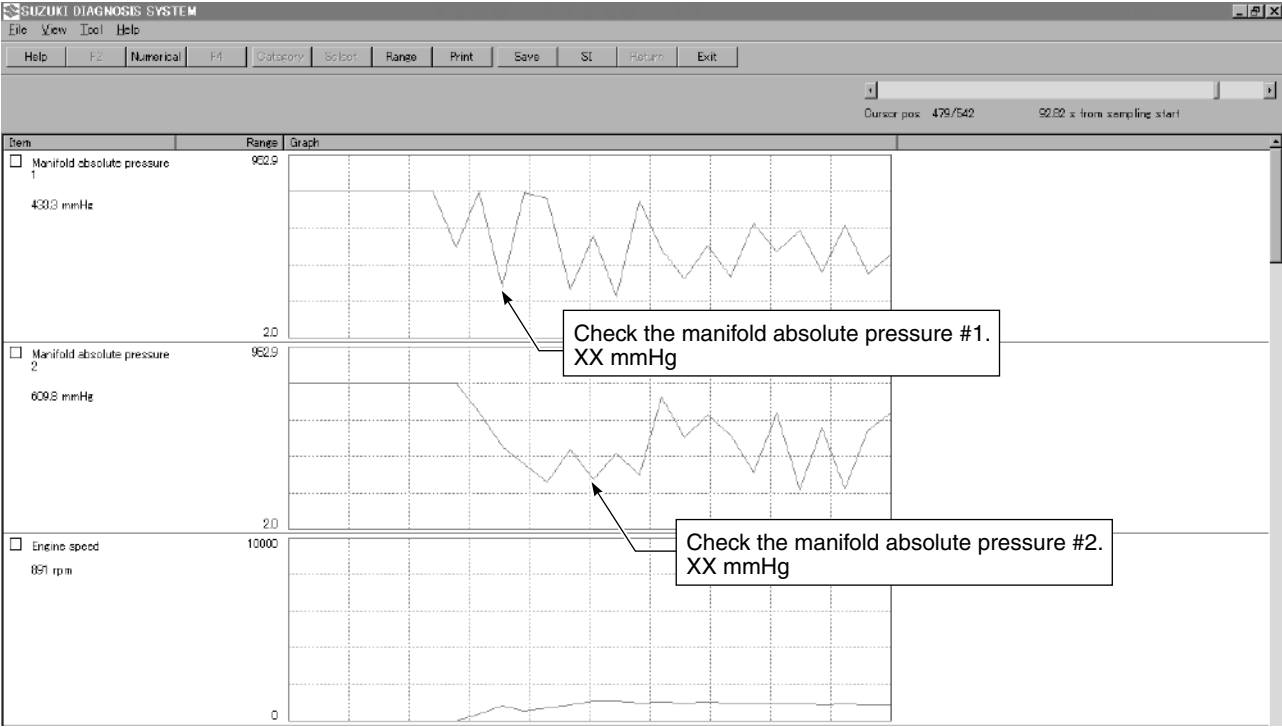



# ENGINE



















## CONTENTS

<b>ENGINE COMPONENTS REMOVABLE WITH ENGINE IN PLACE .....</b>	<b>3- 2</b>
<b>ENGINE REMOVAL AND INSTALLATION.....</b>	<b>3- 3</b>
<b>ENGINE REMOVAL .....</b>	<b>3- 3</b>
<b>ENGINE INSTALLATION .....</b>	<b>3- 9</b>
<b>ENGINE DISASSEMBLY.....</b>	<b>3-13</b>
<b>ENGINE COMPONENTS INSPECTION AND SERVICE.....</b>	<b>3-29</b>
<b>CYLINDER HEAD COVER.....</b>	<b>3-29</b>
<b>CAMSHAFT .....</b>	<b>3-29</b>
<b>CAM CHAIN TENSION ADJUSTER .....</b>	<b>3-32</b>
<b>CAM CHAIN TENSIONER.....</b>	<b>3-32</b>
<b>CAM CHAIN GUIDE .....</b>	<b>3-32</b>
<b>CYLINDER HEAD AND VALVE.....</b>	<b>3-32</b>
<b>CYLINDER.....</b>	<b>3-41</b>
<b>PISTON AND PISTON RING.....</b>	<b>3-42</b>
<b>CLUTCH .....</b>	<b>3-44</b>
<b>GEARSHIFT COVER.....</b>	<b>3-46</b>
<b>STARTER CLUTCH .....</b>	<b>3-47</b>
<b>OIL PUMP.....</b>	<b>3-48</b>
<b>STARTER TORQUE LIMITER .....</b>	<b>3-50</b>
<b>GENERATOR COVER .....</b>	<b>3-50</b>
<b>CLUTCH RELEASE CAMSHAFT .....</b>	<b>3-51</b>
<b>WATER PUMP.....</b>	<b>3-52</b>
<b>GEARSHIFT .....</b>	<b>3-52</b>
<b>OIL PRESSURE REGULATOR.....</b>	<b>3-53</b>
<b>OIL STRAINER.....</b>	<b>3-53</b>
<b>TRANSMISSION.....</b>	<b>3-54</b>
<b>CRANKCASE .....</b>	<b>3-60</b>
<b>BALANCER DRIVEN GEAR.....</b>	<b>3-67</b>
<b>CRANKSHAFT AND CONROD .....</b>	<b>3-69</b>
<b>CRANKSHAFT JOURNAL BEARING .....</b>	<b>3-73</b>
<b>CRANKSHAFT THRUST BEARING .....</b>	<b>3-76</b>
<b>ENGINE REASSEMBLY.....</b>	<b>3-78</b>





















## ENGINE COMPONENTS REMOVABLE WITH ENGINE IN PLACE

The parts listed below can be removed and reinstalled without removing the engine from the frame. Refer to page listed in each section for removal and reinstallation instructions.























### ENGINE CENTER

ITEM	REMOVAL	INSPECTION	INSTALLATION
PAIR control solenoid valve	 12-6	 12-6	 12-7
Oil filter	 2-18, 3-26	—	 2-18, 3-87
Oil cooler	 3-26	—	 3-86
Oil pan	 3-27	—	 3-85
Oil strainer	 3-27	 3-53	 3-84
Oil pressure regulator	 3-27	 3-53	 3-84
Oil pressure switch	 3-26	 10-42	 3-86

### ENGINE RIGHT SIDE

ITEM	REMOVAL	INSPECTION	INSTALLATION
Exhaust pipe and muffler	 7-8	—	 7-10
Cam chain tension adjuster	 3-15, -17	 3-32	 3-107, -108
Starter motor	 3-13	 10-16	 3-113
Clutch	 3-19	 3-44	 3-95
Gear position switch	 3-26	 10-20	 3-87
Primary driven gear	 3-25	—	 3-87
Oil pump	 3-48	 3-48	 3-49
Oil pump driven gear	 3-25	—	 3-87

### ENGINE LEFT SIDE

ITEM	REMOVAL	INSPECTION	INSTALLATION
Generator cover and stator	 3-18	 10-10	 3-50, -110
Generator rotor	 3-22	—	 3-92
Water pump	 8-13	 8-15	 8-16
Thermostat	 8-11	 8-11	 8-12
Starter torque limiter	 3-22	 3-50	 3-93
Starter idle gear assembly	 3-22	—	 3-93
Secondary driven gear	 3-24	 4-6	 3-90
Gearshift shaft	 3-24	 3-52	 3-88

## ENGINE REMOVAL AND INSTALLATION

### ENGINE REMOVAL

Before taking the engine out of the frame, wash the engine using a steam cleaner. Engine removal is sequentially explained in the following steps. Reinstall the engine by reversing the removal procedure.

- Drain engine oil. (☞ 2-17)
- Drain engine coolant. (☞ 2-20)
- Remove the frame side covers. (☞ 9-5)
- Remove the fuel tank. (☞ 6-3)
- Remove the frame head covers and radiator covers. (☞ 9-6)
- Disconnect the battery ⊖ lead wire.



- Remove the air cleaner chamber ①. (☞ 6-13)

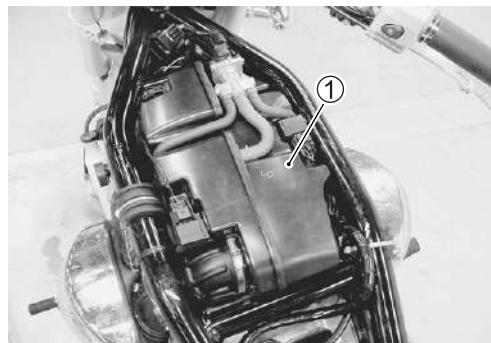

- Remove the exhaust pipes and mufflers ②. (☞ 7-8)

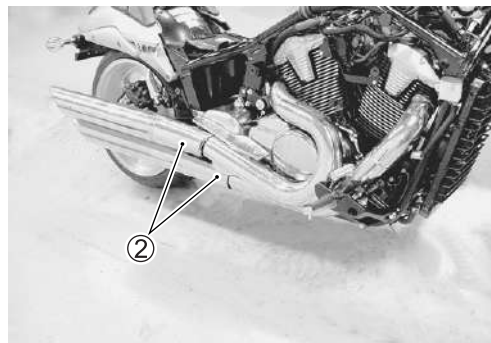

- Remove the throttle body ③. (☞ 6-15)

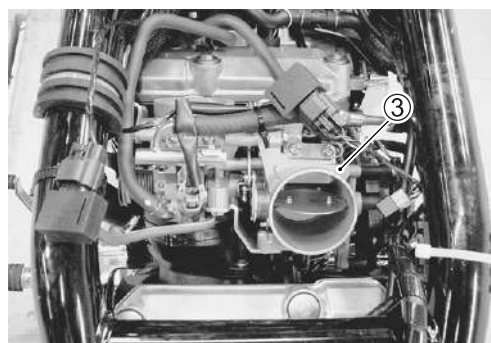

- Disconnect the ECT sensor lead wire coupler ④.

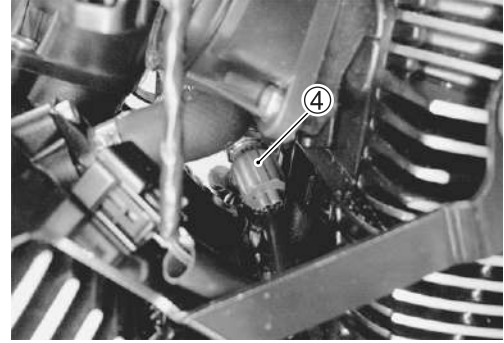

- Disconnect the ignition coil/plug cap lead wire couplers and remove the ignition coils/plug caps. (☞ 2-13 and -14)

**CAUTION**

- \* Do not remove the ignition coil/plug cap before disconnecting its coupler.
- \* Do not pry up the ignition coil/plug cap with a screw driver or a bar to avoid its damage.
- \* Be careful not to drop the ignition coil/plug cap to prevent its short or open circuit.



- Disconnect the spark plug caps. (☞ 2-13 and -14)



- Disconnect the radiator inlet hose ⑤.



- Remove the rear brake fluid reservoir mounting bolt ⑥.
- Remove the master cylinder cover ⑦.

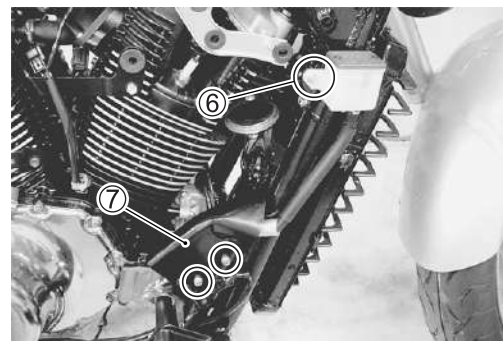

- Remove the right footrest ⑧.

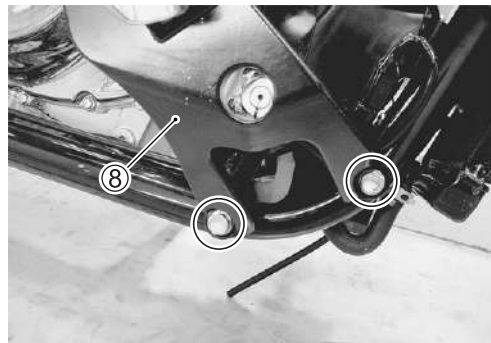

- Disconnect the starter motor lead wire ⑨.

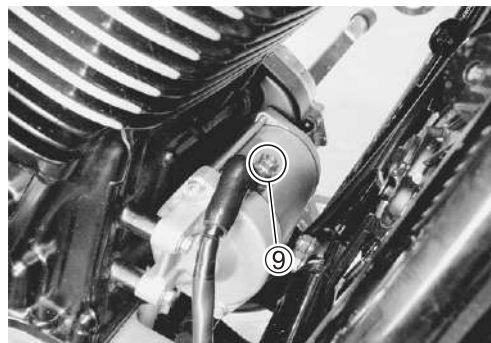

- Disconnect the oil cooler hose ⑩.

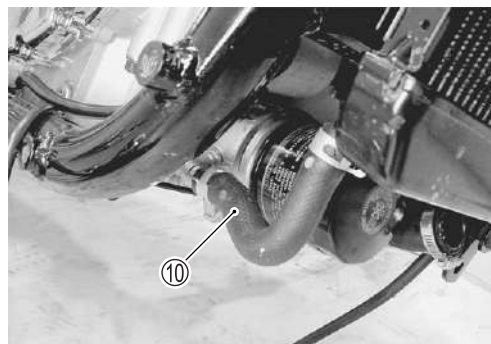

- Remove the oil pressure switch lead wire ⑪.

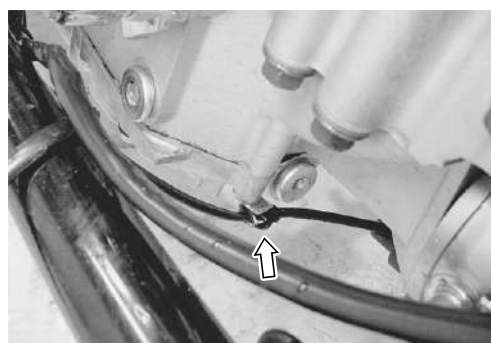



- Disconnect the cooling fan coupler ⑫ and horn lead wire couplers ⑬.

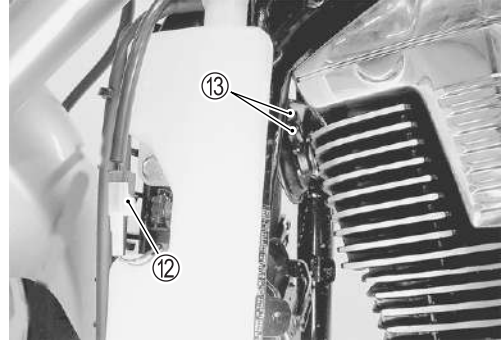

- Remove the left frame lower side cover ⑭.

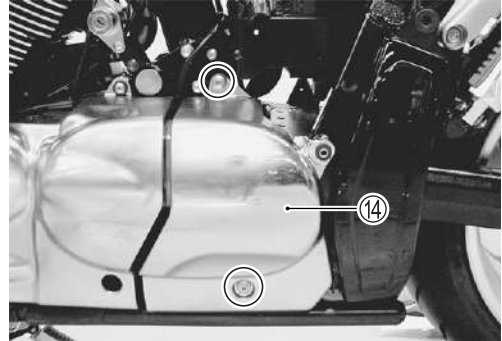

- Remove the secondary gear case cover ⑮.

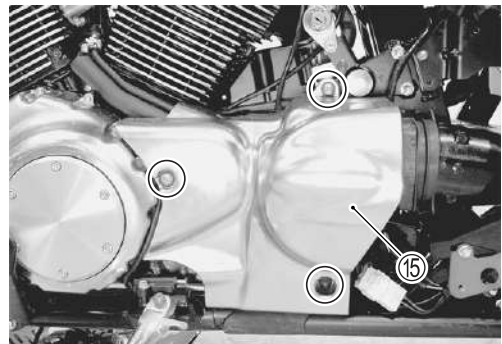

- Disconnect the generator lead wire coupler ⑯.
- Disconnect the CKP sensor lead wire coupler ⑰.
- Disconnect the regulator/rectifier lead wire coupler ⑱.

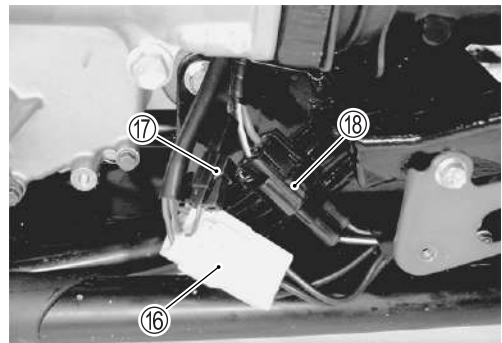

- Disconnect the side-stand switch lead wire coupler ⑲.
- Disconnect the speedometer sensor lead wire coupler ⑳.

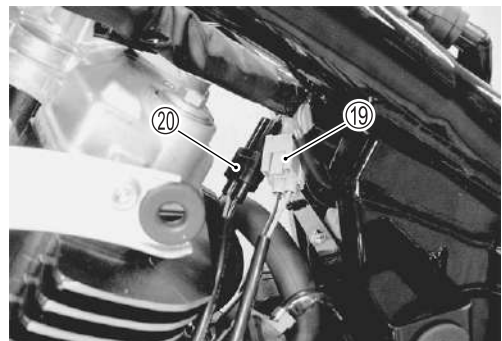

- Remove the clutch cable ⑳.

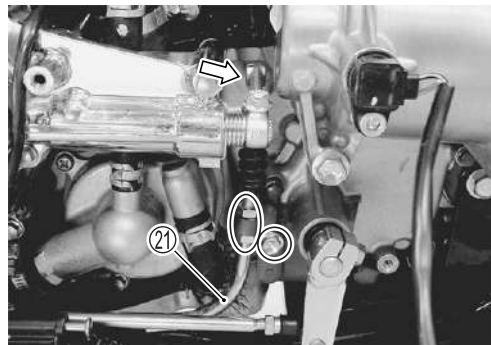

- Support the engine with an engine jack.
- Remove the left footrest ㉒ and gearshift lever ㉓.

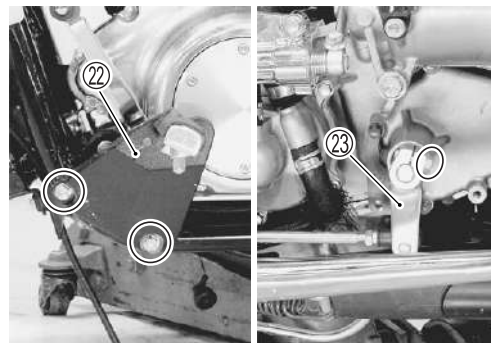

- Remove the ground lead wire ㉔.
- Disconnect the GP switch lead wire coupler ㉕.

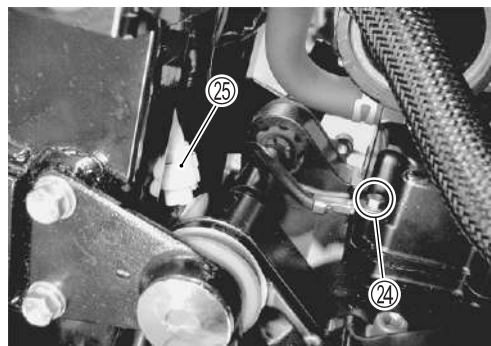

- Remove the engine mounting bolt and nut.



- Slightly move the frame down tube by removing its bolts ②⑥, bolts and nuts ②⑦.

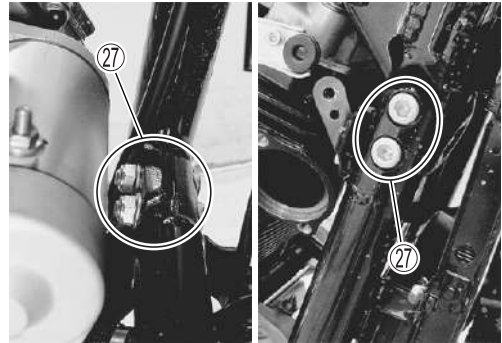

- Remove the caps.

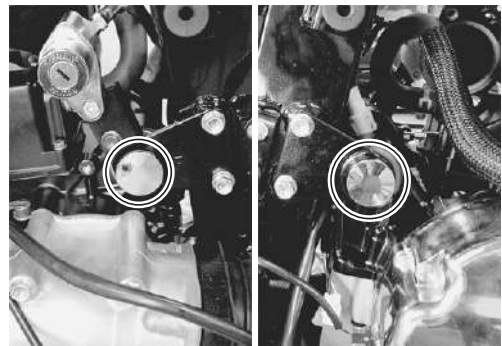

- Remove the engine mounting bracket bolts ②⑧.
- Remove the engine mounting bolts and nuts ②⑨.

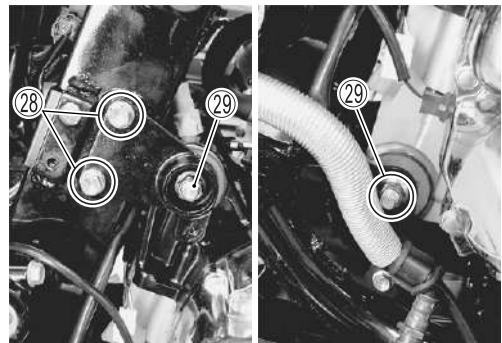

- Remove the the engine assembly.





## ENGINE INSTALLATION

Install the engine in the reverse order of engine removal.

Pay attention to the following points:

- Install the boot and universal joint.

**NOTE:**

Make sure that the "UP" mark  faces up.

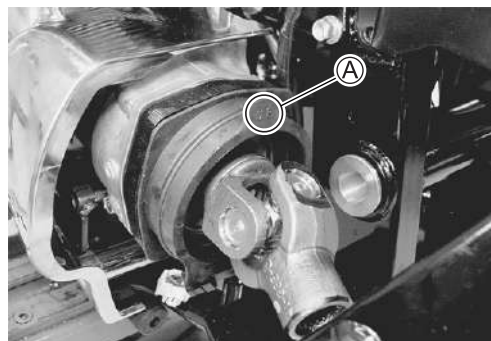

- Gradually raise the engine, and then engage the secondary driven gear shaft to the universal joint.
- Properly fit the boot onto the engine and the swingarm.

### CAUTION

**Be careful not to catch the wiring harness between the frame and the engine.**

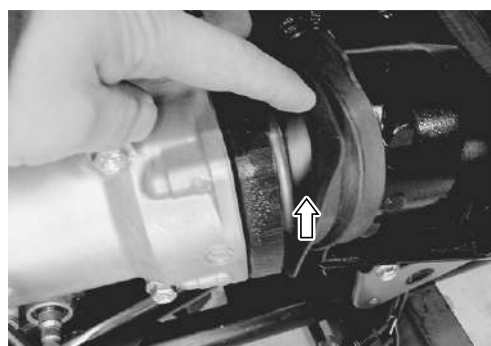

- Install the engine mounting bracket  and tighten its bolts to the specified torque.

### Engine mounting bracket bolt (rear):

**23 N·m (2.3 kgf-m, 16.5 lb-ft)**

- Install the engine mounting bolts and nuts and tighten to the specified torque. ( 3-11)

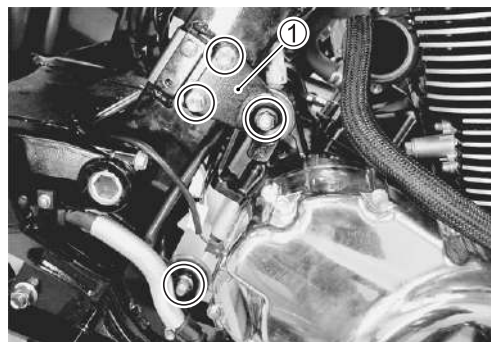

- Install the frame down tube and tighten the bolts ②, bolts and nuts ③ to the specified torque.

**NOTE:**

*The frame down tube nuts are self-locking. Once the nuts have been removed, they are no longer of any use.*

**🔧 Frame down tube bolt: 50 N·m (5.0 kgf-m, 36.0 lb-ft)**

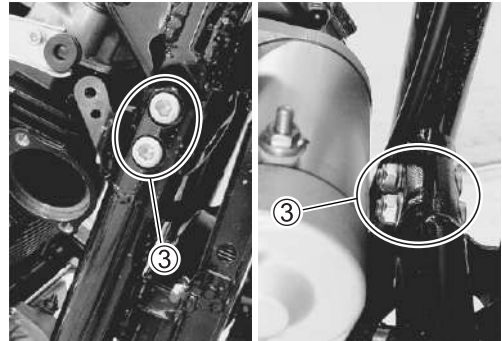

- Install the engine mounting bolt and nut and tighten to the specified torque. (🔧 3-11)

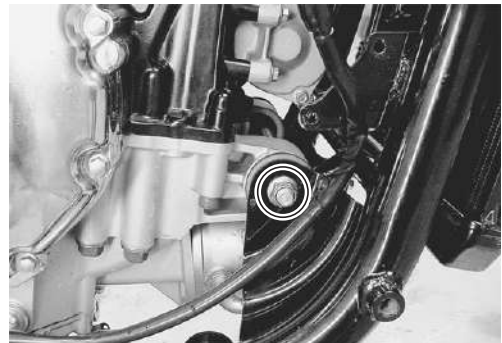

**NOTE:**

The engine mounting nuts are self-locking. Once the nut has been removed, they are no longer of any use.

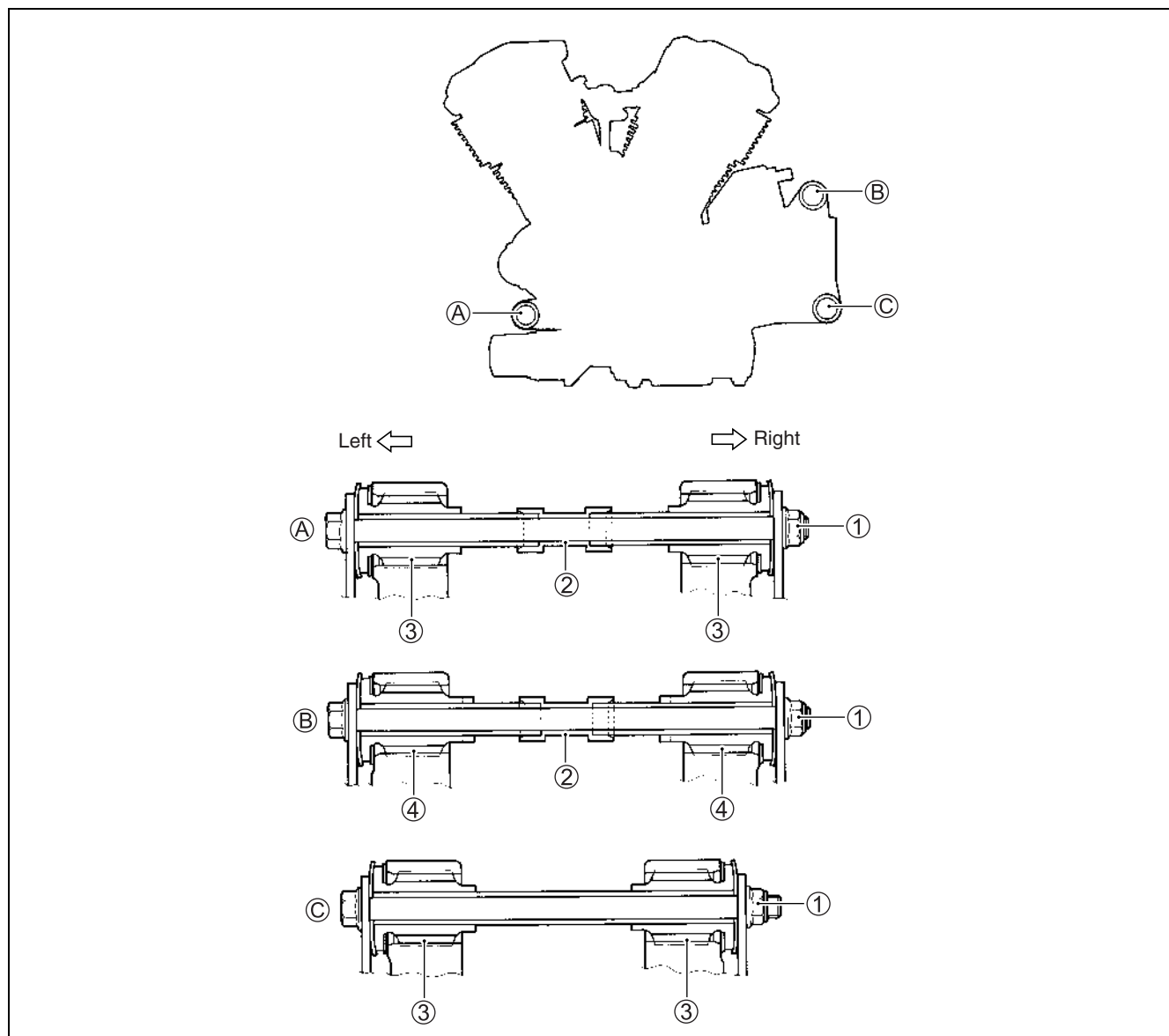

①	Engine mounting nut	③	Bushing
②	Spacer	④	Bushing

ITEM	N·m	kgf·m	lb·ft
①	55	5.5	40.0

- Install the gearshift lever and tighten the mounting bolts to the specified torque.

**Left front footrest bolt: 50 N·m (5.0 kgf·m, 36.0 lb·ft)**

- Footrest in the correct position.

**Gearshift lever height ①**  
**Standard: 45 – 55 mm (1.8 – 2.2 in)**

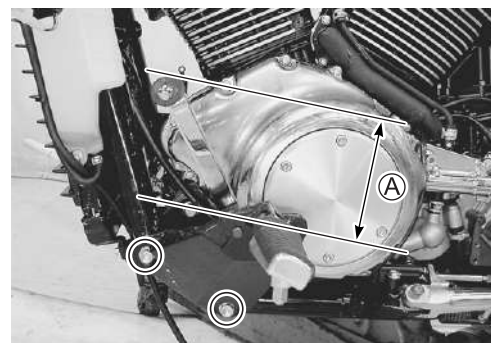

- Tighten the right front footrest mounting bolts to the specified torque.

**🔧 Right front footrest bolt: 60 N-m (6.0 kgf-m, 43.5 lb-ft)**

- Install the rear brake master cylinder cover ④. (🔧 9-72)

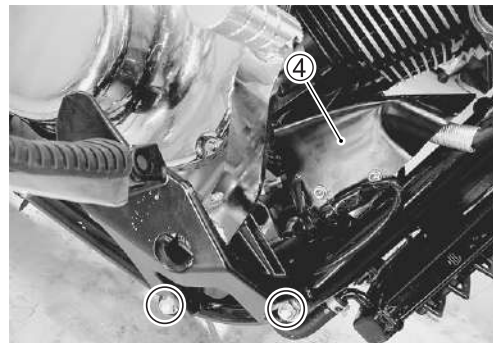

- Install the throttle body. (🔧 6-21)
- Install the exhaust pipe and muffler. (🔧 7-10)
- Perform service and adjustment in the following items.
  - \* Engine oil (🔧 2-17)
  - \* Engine coolant (🔧 2-21)
  - \* Throttle cable play (🔧 2-19)
  - \* Throttle valve synchronization (🔧 6-23)
  - \* Wiring harness, cables and hoses (🔧 11-35 to -44)

## ENGINE DISASSEMBLY

### CAUTION

Identify the position of each removed part. Organize the parts in their respective groups (e.g., intake, exhaust) so that they can be reinstalled in their original positions.

- Remove the front and rear spark plugs.

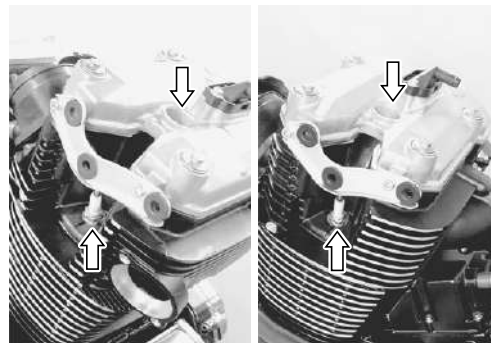

### STARTER MOTOR

- Remove the starter motor ①.

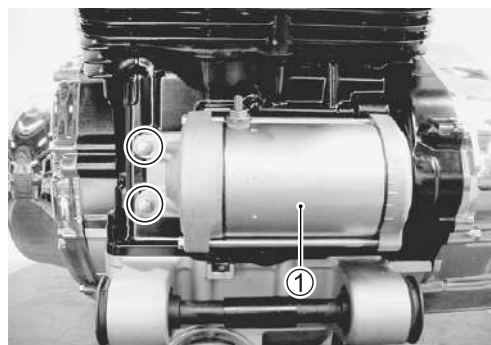

### INTAKE PIPE

- Remove the front and rear intake pipes ①.

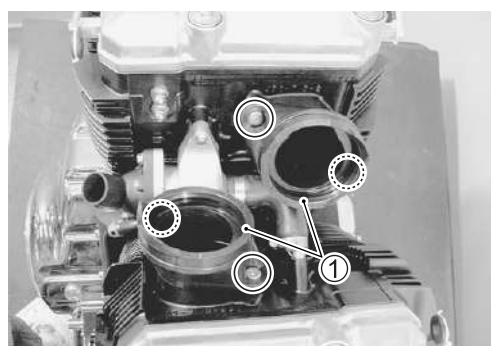

### THERMOSTAT

- Remove the thermostat assembly ① and disconnect the water hoses (②, ③).

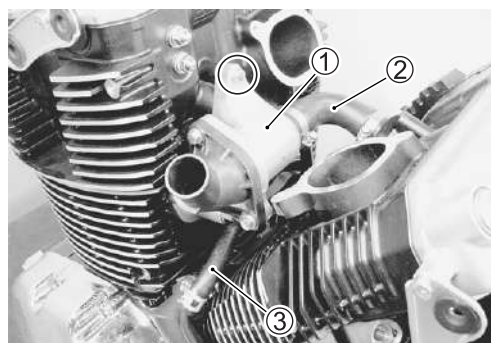

### REAR CYLINDER HEAD COVER

- Remove the right and left head cover brackets ①.

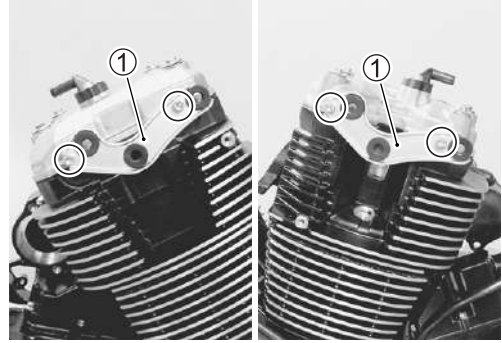

- Remove the rear cylinder head cover ② and its gasket.

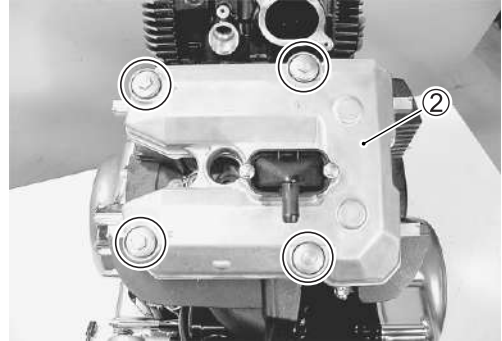

### REAR CAMSHAFT

- Remove the generator cover cap ①.

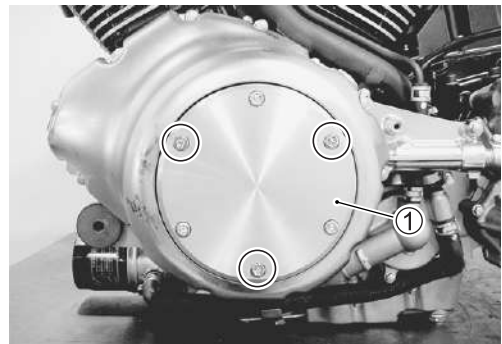

- Remove the valve timing inspection plug ② and generator cover plug ③.

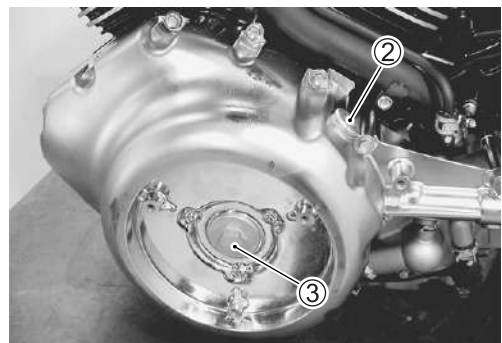



- Turn the crankshaft to bring the “R I T” line on generator rotor to the index mark of the valve inspection hole and also to bring the cams to the position as shown.

**NOTE:**

At the above condition, the rear cylinder is at TDC of compression stroke and also the engraved lines (A) on the camshafts are parallel with the mating surface of the cylinder head cover.

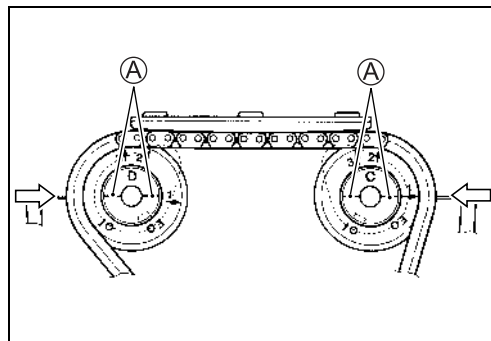
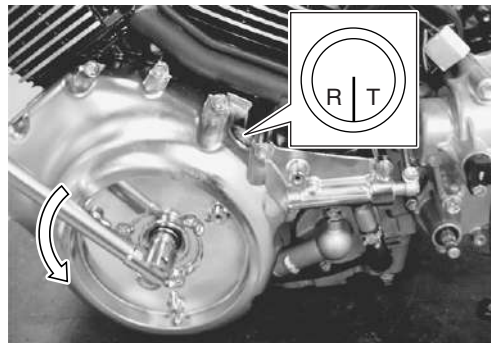

- Remove the cam chain tension adjuster cap bolt (4) and spring.
- Remove the rear cam chain tension adjuster No. 2 (5) and gasket.

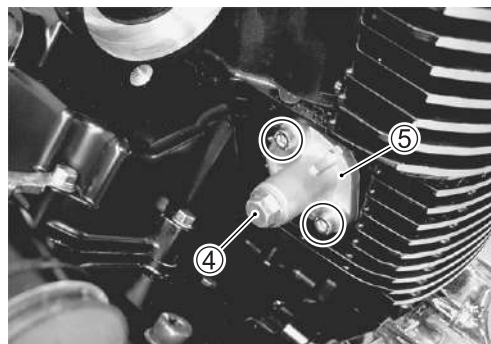

- Remove the cam chain guide No. 3 (6).
- Remove the camshaft journal holder (7).
- Remove the dowel pins.

**CAUTION**

Be sure to loosen the camshaft journal holder bolts evenly by shifting the wrench in the descending order of numbers.

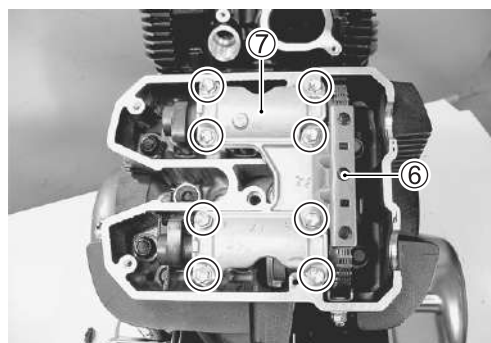

- Remove the intake camshaft (8).
- Remove the exhaust camshaft (9).

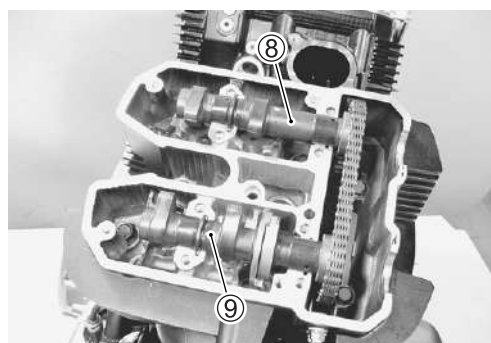

### REAR CYLINDER HEAD

- Remove the cylinder head bolts and washers.

**NOTE:**

*Loosen the cylinder head bolts little by little diagonally with the smaller sizes first.*

- Remove the cylinder head ①.

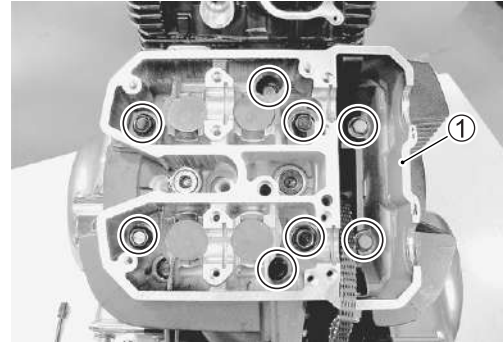

### REAR CYLINDER

- Remove the cylinder head gasket ①, dowel pins ② and cam chain guide No. 2 ③.

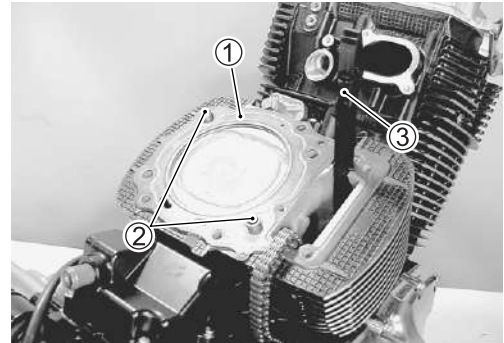

- Remove the clutch cover ④.
- Remove the dowel pins and gasket.

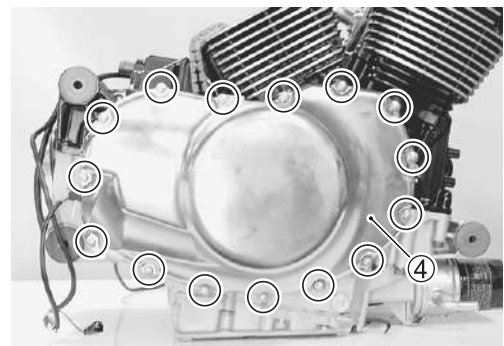

- Remove the cylinder nuts.
- Remove the cylinder ⑤.

**NOTE:**

*Firmly grip the cylinder at both ends, and lift it straight up. If the cylinder does not come off, lightly tap on the finless portions of the cylinder with a plastic mallet to make the gasketed joint loose.*

- Remove the cylinder gasket and dowel pins.

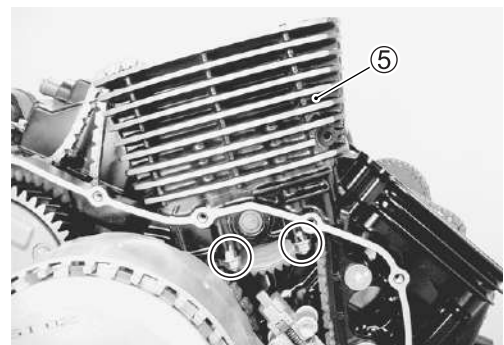

### REAR PISTON

- Place a clean rag over the cylinder base so as not to drop the piston pin circlip into the crankcase.
- Remove the piston pin circlip.
- Remove the piston pin and piston.

**NOTE:**

*Scribe the cylinder number on the head of the piston.*

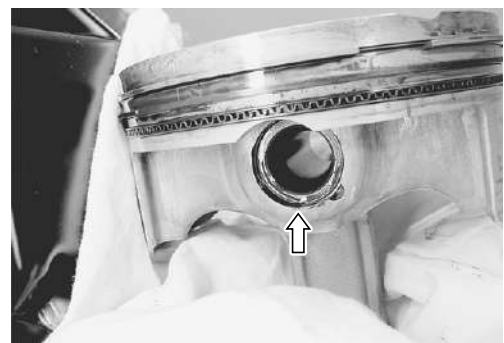



## FRONT CYLINDER HEAD COVER

- Remove the right and left head cover brackets ①.

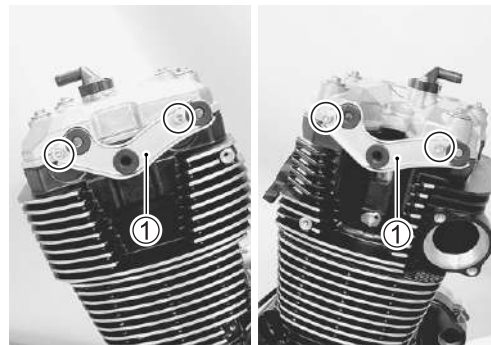

- Remove the front cylinder head cover ② and its gasket.

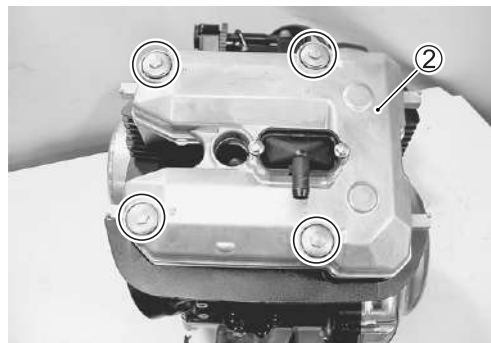

## FRONT CAMSHAFT

- Turn the crankshaft to bring the “F I T” line mark on generator rotor to the index mark of the valve inspection hole and also to bring the cams to the position as shown.

### NOTE:

At the above condition, the front cylinder is at TDC on expansion stroke and also the engraved lines (A) on the camshafts are parallel with the mating surface of the cylinder head cover.

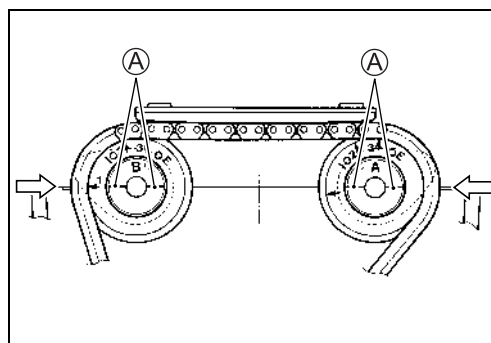
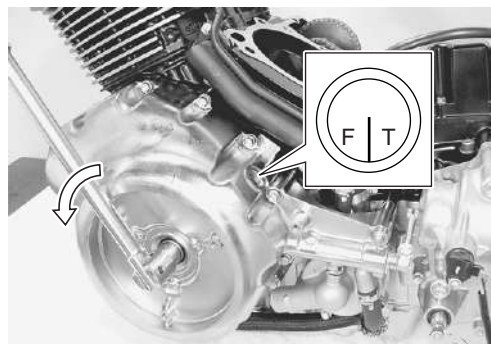

- Remove the cam chain tension adjuster cap bolt ③, washer and spring.
- Remove the front cam chain tension adjuster No. 2 ④ and gasket.

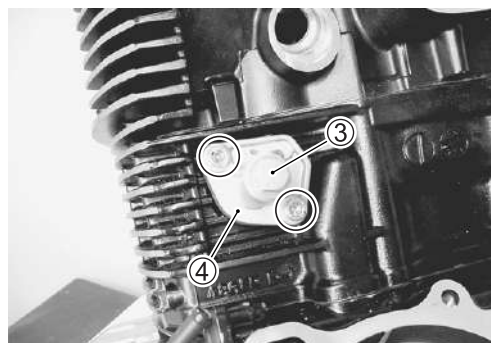

- Remove the cam chain guide No. 3 ⑤.
- Remove the camshaft journal holder ⑥.
- Remove the dowel pins.

**CAUTION**

Be sure to loosen the camshaft journal holder bolts evenly by shifting the wrench in the descending order of numbers.

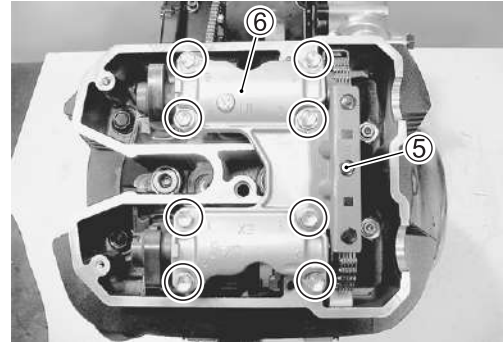

- Remove the intake camshaft ⑦.
- Remove the exhaust camshaft ⑧.

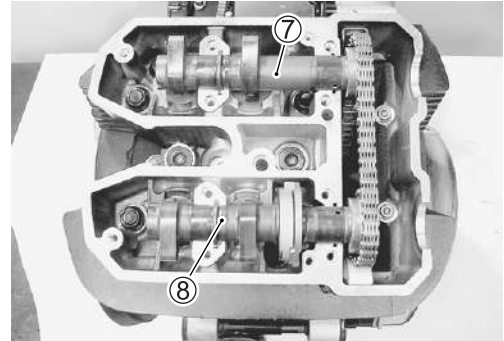

**FRONT CYLINDER HEAD**

- Remove the cylinder head bolts and washers.

**NOTE:**

Loosen the cylinder head bolts little by little diagonally with the smaller sizes first.

- Remove the cylinder head ①.

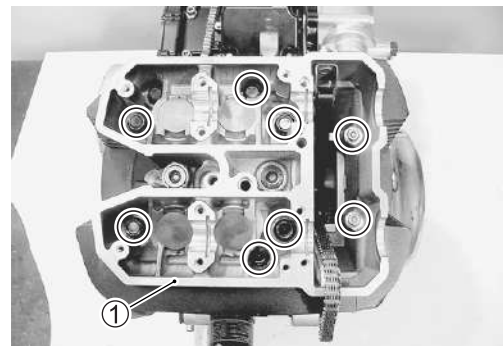

**FRONT CYLINDER**

- Remove the cylinder head gasket ①, dowel pins ② and cam chain guide No. 2 ③.

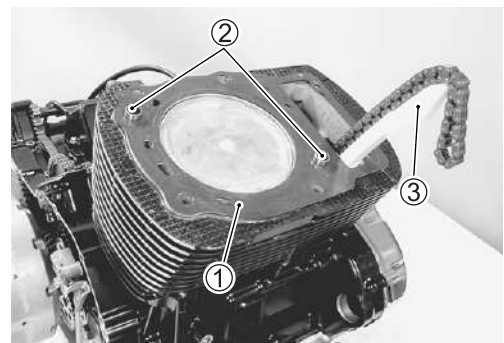

- Remove the generator cover ④.
- Remove the dowel pins and gasket.

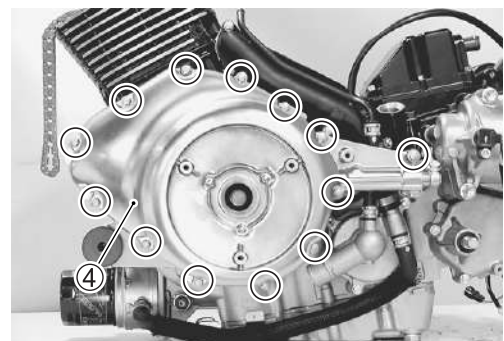

- Remove the cylinder nuts.
- Remove the cylinder ⑤.

**NOTE:**

*Firmly grip the cylinder at both ends, and lift it straight up. If the cylinder does not come off, lightly tap on the finless portions of the cylinder with a plastic mallet to make the gasketed joint loose.*

- Remove the cylinder gasket and dowel pins.

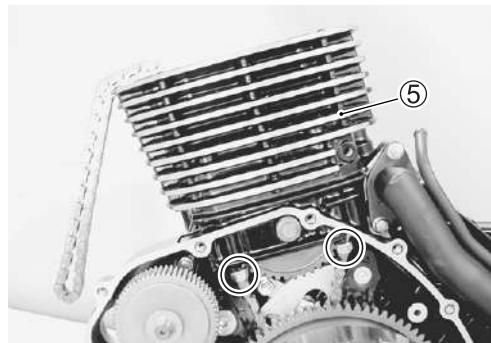
**FRONT PISTON**

- Place a clean rag over the cylinder base so as not to drop the piston pin circlip into the crankcase.
- Remove the piston pin circlip.
- Remove the piston pin and piston.

**NOTE:**

*Scribe the cylinder number on the head of the piston.*

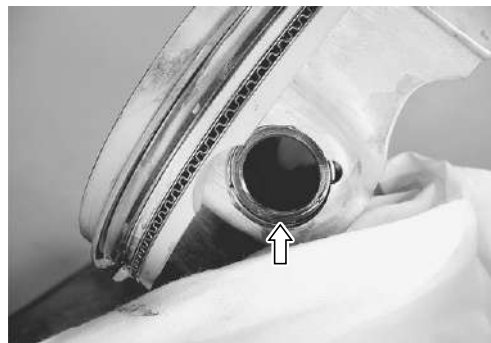
**CLUTCH**

- Hold the generator rotor.



- Remove the clutch spring set bolts and springs.

**NOTE:**

*Loosen the clutch spring set bolts little by little and diagonally.*

- Remove the pressure plate ①.

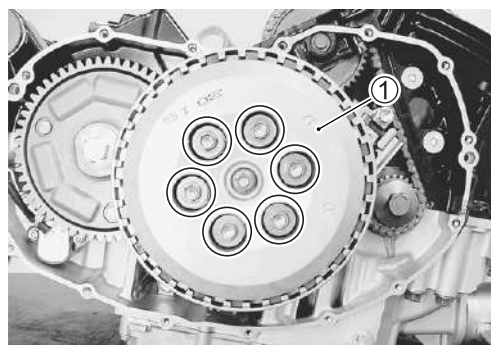

- Remove the clutch push piece ②, thrust washer ③ and the bearing ④.

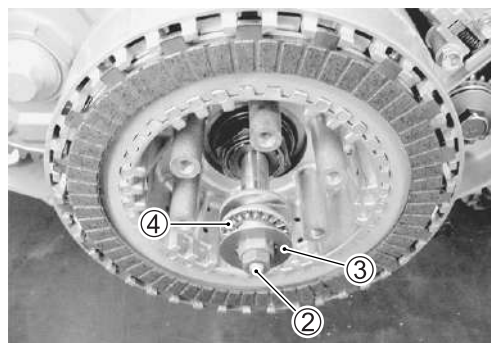



- Remove the clutch push rod ⑤ and clutch push rod release ball ⑥.

**NOTE:**

*If it is difficult to pull out the push rod ⑤ and ball ⑥, use a long-bar.*

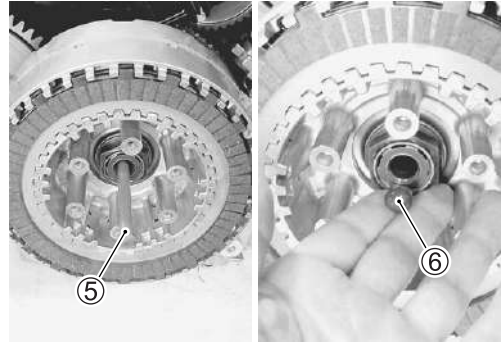

- Unlock the clutch sleeve hub nut.

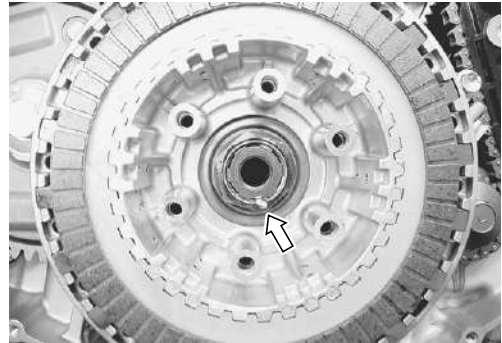

- Hold the generator rotor with a 41 mm offset wrench.



- Remove the clutch sleeve hub nut.



- Remove the spring washer ⑦, clutch drive plates ⑧ and driven plates ⑨ with the clutch sleeve hub ⑩.

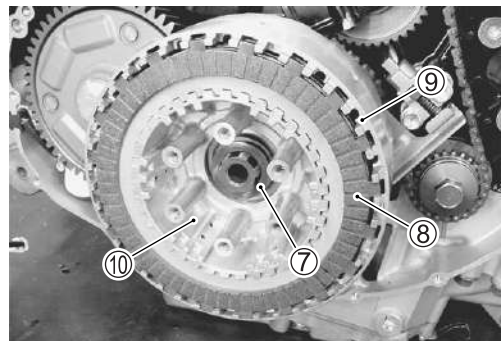

- Remove the thrust washer ⑪.
- Remove the primary driven gear assembly ⑫.

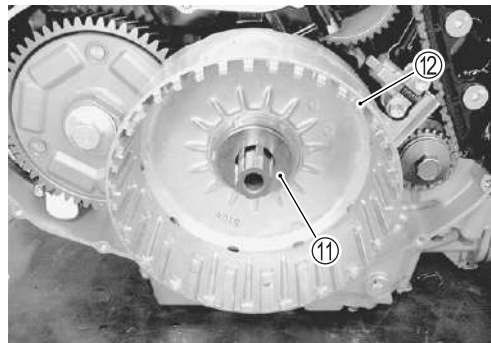

- Remove the needle roller bearing ⑬ and spacer ⑭.

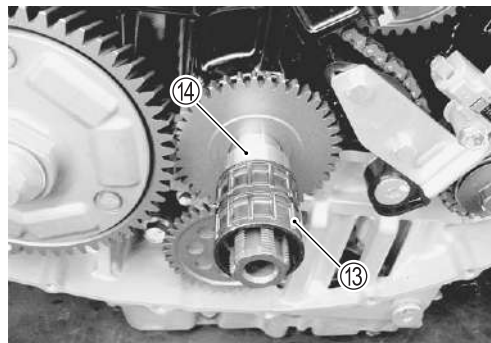

#### REAR CAM CHAIN TENSION ADJUSTER

- Unlock the ratchet ① and insert the special tool.

 **09917-62430: Chain tensioner lock tool**

- Remove the rear cam chain tensioner No. 1 assy ②.

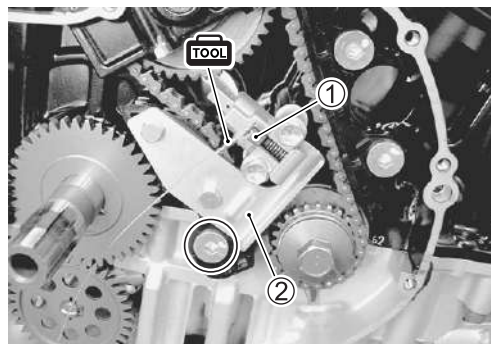

- Remove the cam chain guide No. 1 ③ and rear cam chain tension adjuster No. 1 ④.



#### REAR CAM CHAIN IDLER SPROCKET

- Remove the idler shaft ①.
- Disengage the cam chain No. 1 ② from the rear cam chain idler sprocket ③.

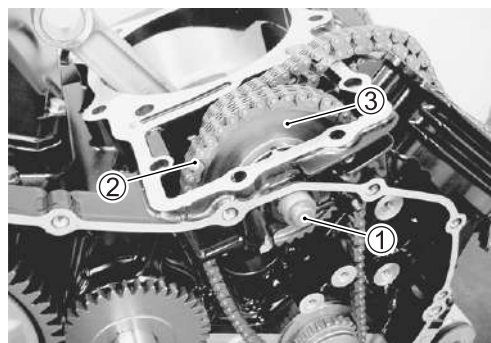

- Remove the cam chain No. 2 ④, rear cam chain idler sprocket ⑤ and cam chain No. 1.

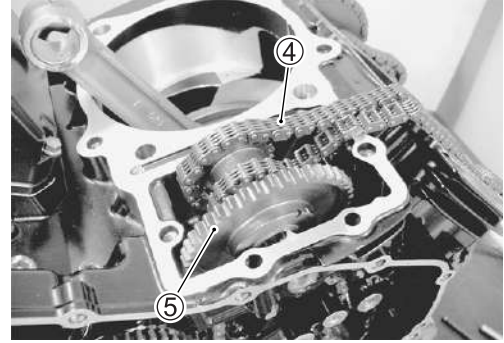

### REAR CAM CHAIN DRIVE SPROCKET

- Hold the generator rotor and remove the rear cam chain drive sprocket bolt.

#### CAUTION

This bolt has left-hand thread.

- Remove the rear cam chain drive sprocket ①.

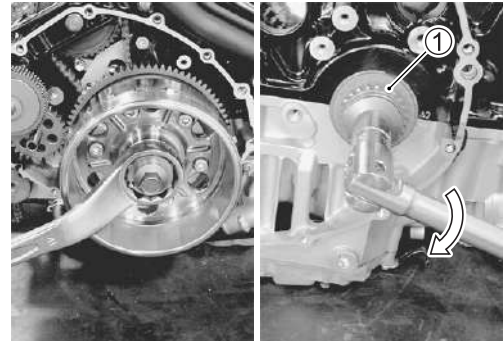

### STARTER TORQUE LIMITER/STARTER IDLE GEAR

- Remove the washer ①, starter torque limiter ② and washer.
- Remove the shaft ③ and starter idle gear ④.

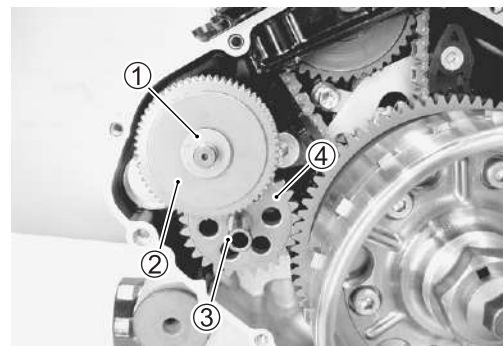

- Remove the bushings ⑤ from the crankcase and generator.

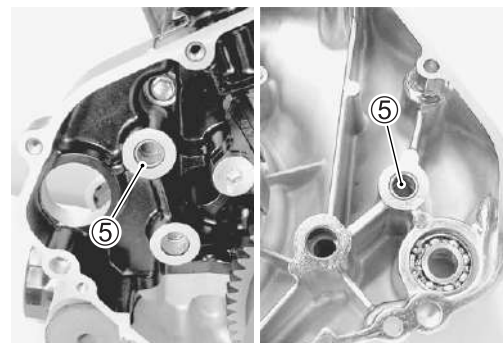

### GENERATOR

- Loosen the generator rotor bolt.

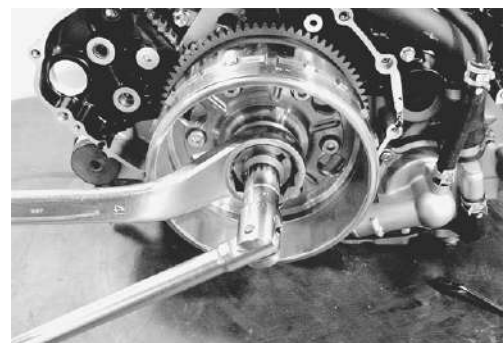



**NOTE:**

When loosen the rotor bolt, do not remove it. The rotor bolt is used in conjunction with the rotor remover when removing the rotor.

- Remove the generator rotor assembly with the special tool.

 **09930-30721: Rotor remover**

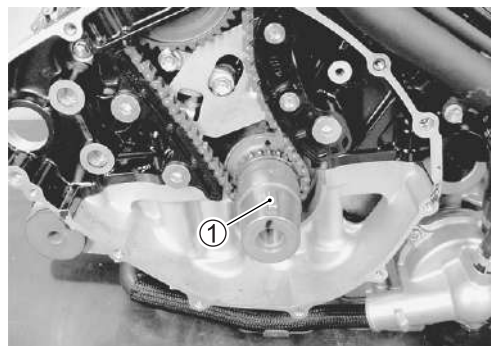

- Remove the key ①.

**FRONT CAM CHAIN IDLER SPROCKET**

- Loosen the front cam chain tensioner No. 1 mounting bolt ① and remove the cam chain guide No. 1 ②.

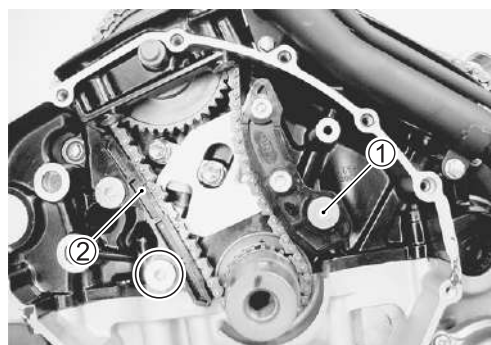

- Remove the idler shaft ③.
- Disengage the cam chain No. 1 ④ from the front cam chain idler sprocket ⑤.

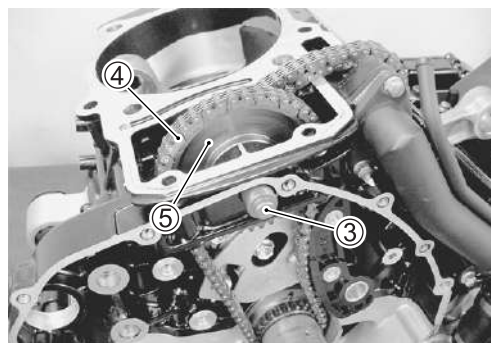

- Remove the cam chain tensioner No. 1 ⑥.
- Remove the cam chain No. 2 ⑦, front cam chain idler sprocket ⑧ and cam chain No. 1 ⑨.

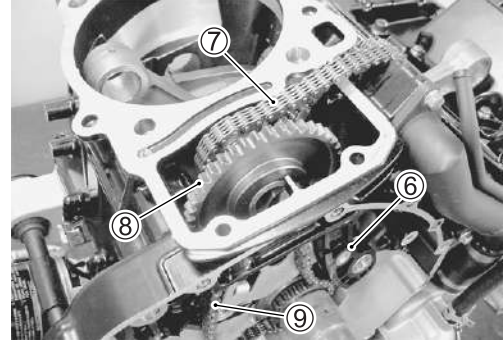

- Remove the front cam chain tension adjuster No. 1 ⑩.



### SECONDARY DRIVEN GEAR

- Remove the secondary driven gear assembly ① and shims.

### SECONDARY DRIVEN GEAR INSPECTION (☞ 4-6)

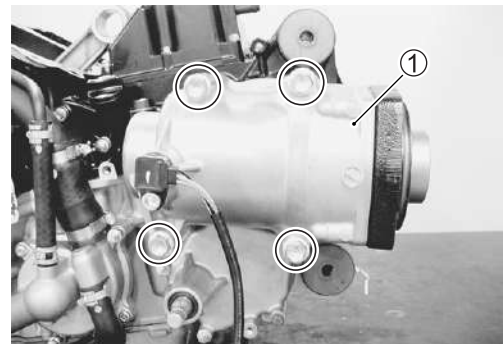

### GEARSHIFT

- Remove the gearshift cover ①.
- Remove the gasket and dowel pins.

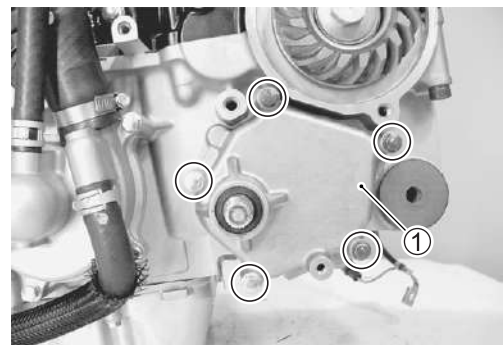

- Draw out the gearshift shaft assembly ②.

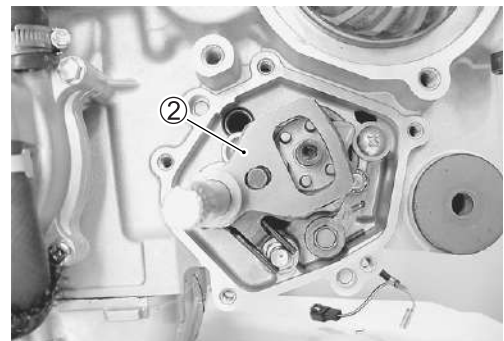



- Remove the gearshift cam plate ③.
- Remove the gearshift cam stopper ④.

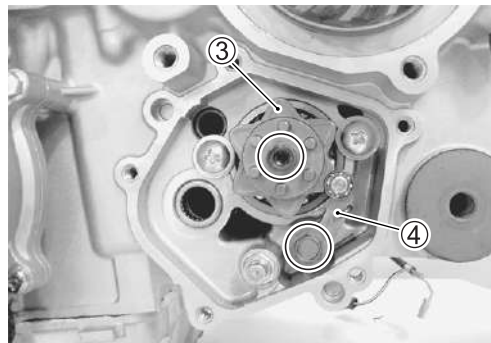

### SECONDARY DRIVE GEAR

- Shift the gear position to 1st or 2nd.
- Hold the primary driven gear with the special tool.

**TOOL** 09930-44541: Rotor holder

- Remove the secondary drive gear bolt.
- Secondary drive gear ① removal. (↗ 3-28)

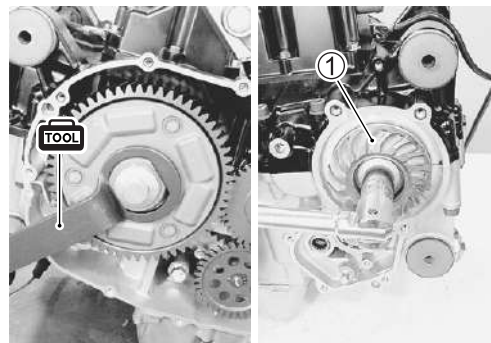

### SECONDARY DRIVE GEAR SERVICING (↗ 4-10)

### PRIMARY DRIVEN GEAR

- Hold the primary driven gear with the special tool and remove the primary driven gear bolt.

**TOOL** 09930-44541: Rotor holder

- Remove the primary driven gear ①.

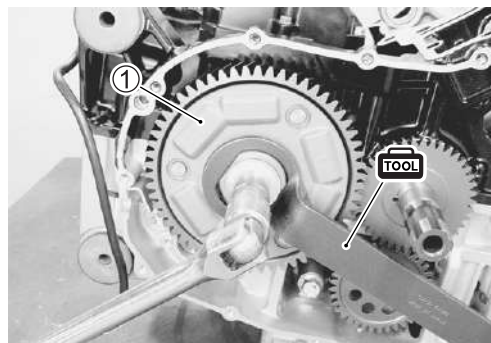

### OIL PUMP DRIVEN GEAR AND DRIVE GEAR

- Remove the snap ring ①.
- Remove the oil pump driven gear ②.

#### NOTE:

Do not drop the snap ring ① into the crankcase.

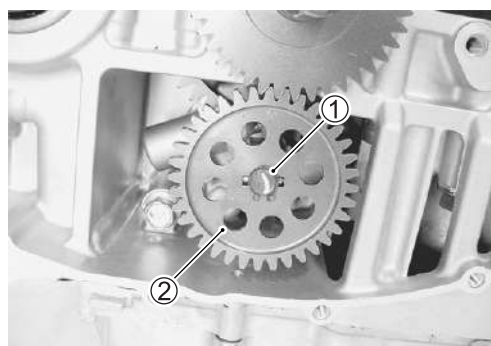

- Remove the pin ③ and washer ④.

#### NOTE:

Do not drop the pin ③ and washer ④ into the crankcase.

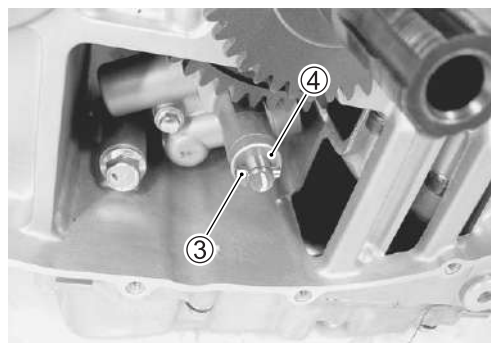

- Remove the oil pump drive gear ⑤ and pin ⑥.

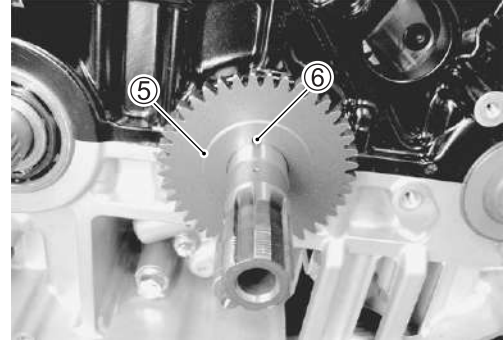

### GEAR POSITION SWITCH

- Remove the gear position switch ①.



### OIL FILTER

- Remove the oil filter with the special tool.

 09915-40610: Oil filter wrench

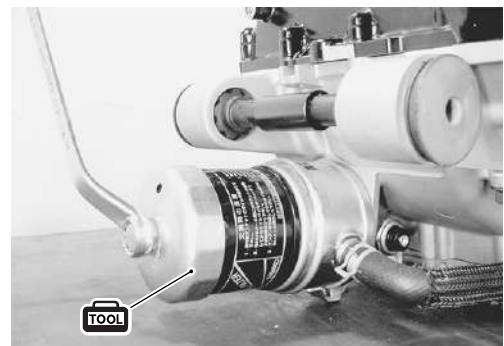

### OIL COOLER/OIL PRESSURE SWITCH

- Disconnect the water hose ①.
- Remove the oil cooler ② by removing the union bolt.
- Remove the oil pressure switch ③.

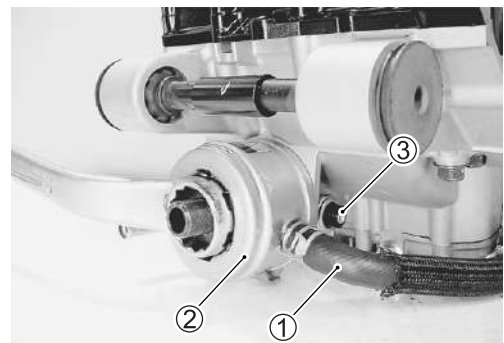

### WATER PUMP

- Disconnect the water hose ①.
- Remove the water inlet pipe ②, water bypass pipe ③ and water pump ④.

### WATER PUMP SERVICING ( 8-13)

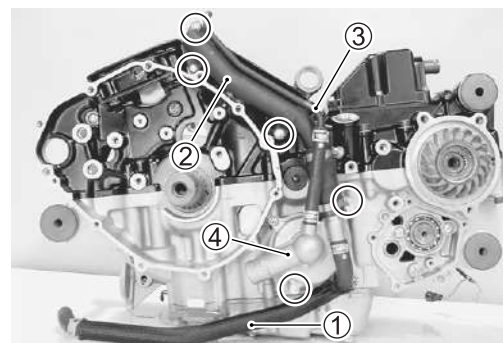

**OIL PAN**

- Remove the oil pan ① and stay ②.

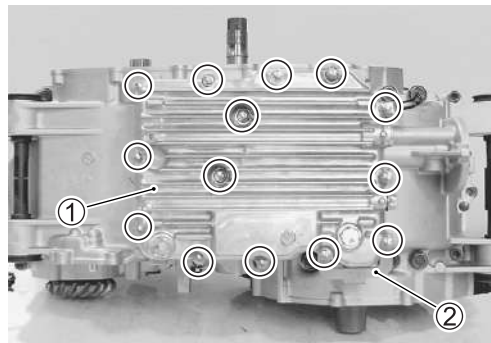
**OIL PRESSURE REGULATOR**

- Remove the oil pressure regulator ①.

**OIL STRAINER**

- Remove the oil strainers ② and O-rings ③.

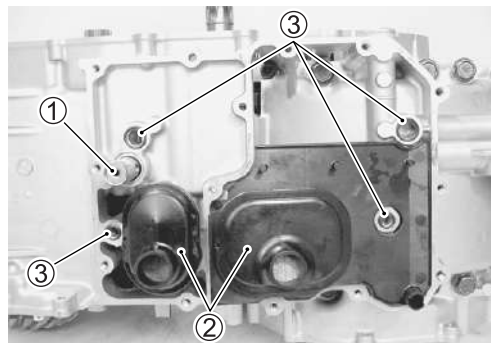
**UPPER CRANKCASE**

- Remove the breather cover ①.
- Remove the upper crankcase bolts.

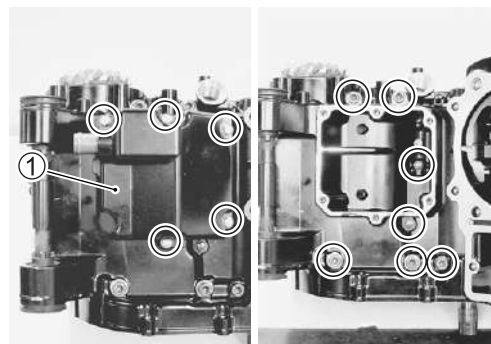
**LOWER CRANKCASE**

- Remove the lower crankcase bolts.

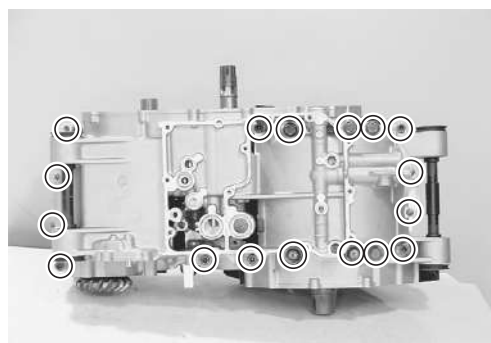

- Make sure that all of the bolts are removed. Then, tap the sides of the lower crankcase using a plastic mallet to separate the upper and lower crankcase halves and then lift the lower crankcase off of the upper crankcase.

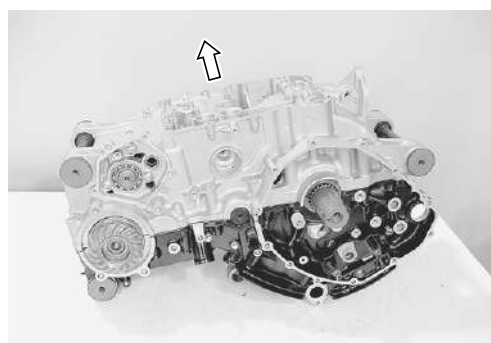

**NOTE:**

- \* The crankshaft and transmission components should remain in the upper crankcase half.
- \* If it is difficult to separate the crankcase halves, set the proper bolts and nuts to the crankcase by separating the upper and lower crankcase halves, as shown in the illustration.

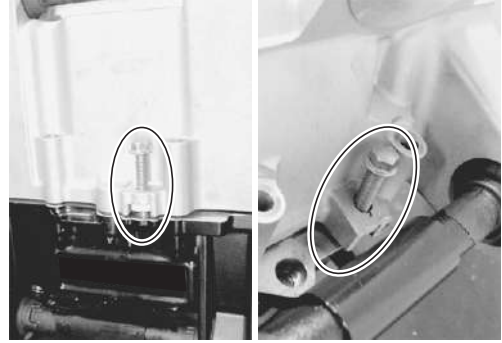
**TRANSMISSION**

- Remove the driveshaft assembly ① and countershaft assembly ②.
- Remove the O-rings ③ and dowel pin ④.

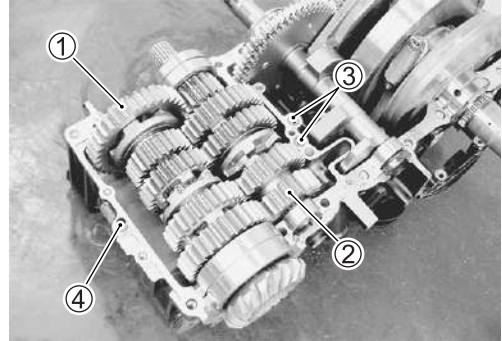
**BALANCER SHAFT**

- Remove the oil seal ① and balancer shaft ②.

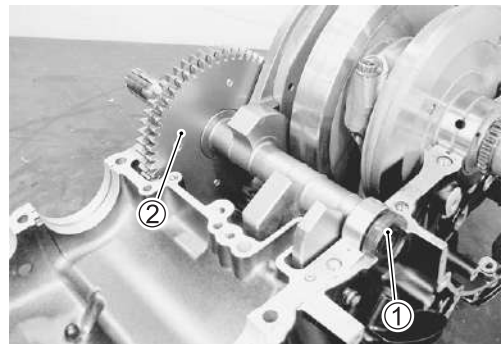
**CRANKSHAFT**

- Remove the O-ring ① and dowel pins ②.
- Remove the crankshaft ③ and thrust bearing ④.

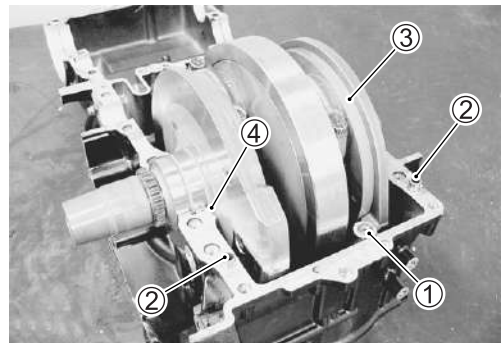



## ENGINE COMPONENTS INSPECTION AND SERVICE

### CAUTION

Identify the position of each removed part. Organize the parts in their respective groups (i.e., intake, exhaust, No.1 or No.2) so that they can be installed in their original locations.

## CYLINDER HEAD COVER

### DISASSEMBLY

- Remove the PAIR reed valve cover ① and PAIR reed valve ②.

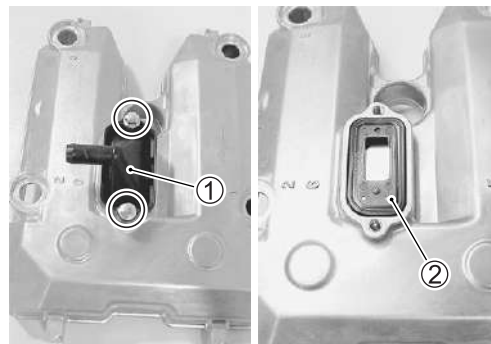

### INSPECTION

- Inspect the PAIR reed valve for the carbon deposit.
- If the carbon deposit is found in the reed valve, replace the PAIR reed valve with a new one.



### INSTALLATION

- Install the PAIR reed valve and PAIR reed valve cover.
- Apply THREAD LOCK to the bolts and tighten them.

 **99000-32050: THREAD LOCK "1342" or equivalent**

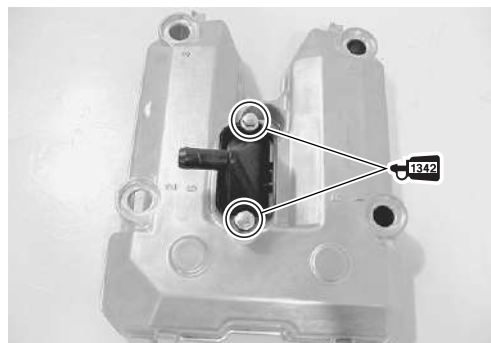

## CAMSHAFT

### CAMSHAFT IDENTIFICATION

The camshafts can be identified by the engraved letter.

- "A" Front intake camshaft
- "B" Front exhaust camshaft
- "C" Rear intake camshaft
- "D" Rear exhaust camshaft

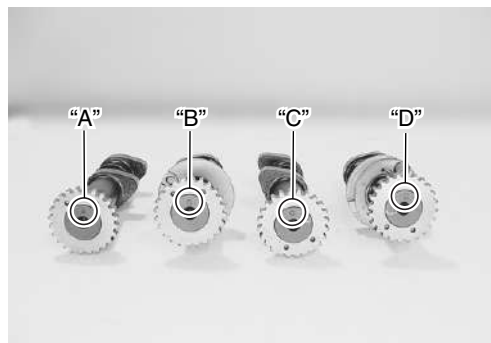

**CAM WEAR**

- Check the camshaft for wear or damage.
- Measure the cam height  $\ominus$  with a micrometer.

**DATA** Cam height  $\ominus$ :

**Service Limit: (IN. & EX.): 40.580 mm (1.5976 in)**

**TOOL** 09900-20202: Micrometer (25 – 50 mm)

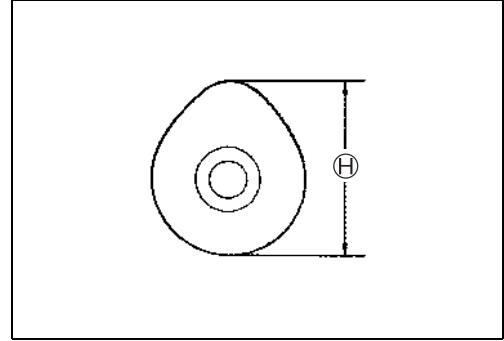
**CAMSHAFT JOURNAL WEAR**

- Determine whether or not each journal is worn down to the limit by measuring the oil clearance with the camshaft installed in place.
- Use the plastigauge  $\textcircled{A}$  to read the clearance at the widest portion, which is specified as follows:

**DATA** Camshaft journal oil clearance:

**Service Limit: (IN. & EX.): 0.150 mm (0.0059 in)**

**TOOL** 09900-22301: Plastigauge

09900-22302: Plastigauge

**NOTE:**

*Install camshaft journal holder to their original positions.*

- Tighten the camshaft journal holder bolts evenly and diagonally to the specified torque. (☞ 3-104)

**🔧 Camshaft journal holder bolt: 11 N·m (1.1 kgf-m, 8.0 lb-ft)**

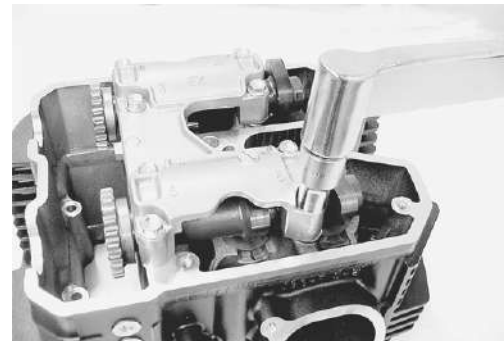
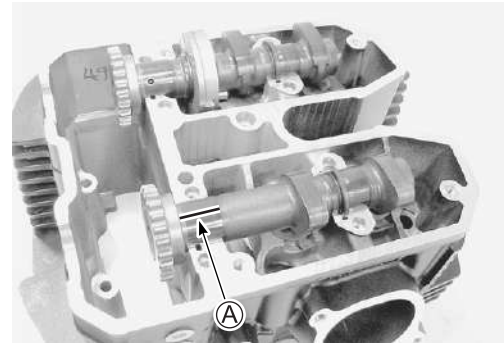
**NOTE:**

*Do not rotate the camshaft with the plastigauge in place.*

- Remove the camshaft journal holders, and read the width of the compressed plastigauge with envelope scale.
- This measurement should be taken at the widest part.

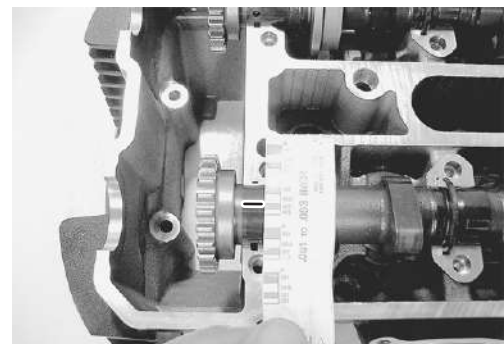

- If the camshaft journal oil clearance measured exceeds the limit, measure the inside diameter of the camshaft journal holder and outside diameter of the camshaft journal.
- Replace the camshaft or the cylinder head depending upon which one exceeds the specification.

**DATA** Camshaft journal holder I.D.:

Standard: (IN. & EX.):

24.012 – 24.025 mm (0.9454 – 0.9459 in)

**TOOL** 09900-20602: Dial gauge (1/1 000, 1 mm)

09900-22403: Small bore gauge (18 – 35 mm)

**DATA** Camshaft journal O.D.:

Standard (IN. & EX.):

23.959 – 23.980 mm (0.9433 – 0.9441 in)

**TOOL** 09900-20205: Micrometer (0 – 25 mm)

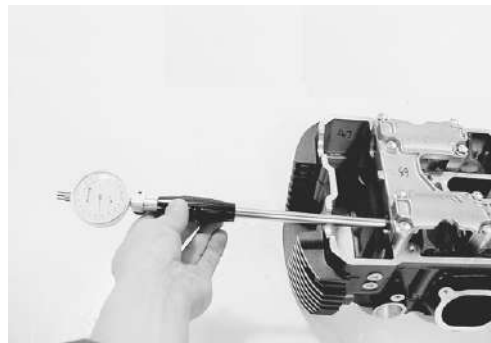

### CAMSHAFT RUNOUT

- Measure the runout using the dial gauge.
- Replace the camshaft if the runout exceeds the limit.

**DATA** Camshaft runout:

Service Limit (IN. & EX.): 0.10 mm (0.004 in)

**TOOL** 09900-20607: Dial gauge (1/100 mm, 10 mm)

09900-20701: Magnetic stand

09900-21304: V-block set (100 mm)

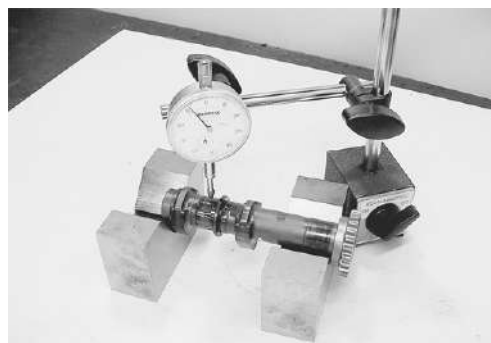

### CAM SPROCKET AND AUTOMATIC-DECOMP.

- Inspect the cam sprocket teeth for wear and damage.
- Inspect the automatic-decomp. for damage and smooth operation.
- If there are unusual, replace the camshaft assembly and cam chain as a set.

**CAUTION**

**Do not attempt to disassemble the cam sprockets and automatic-decomp. assembly. They are unserviceable.**



## CAM CHAIN TENSION ADJUSTER

### INSPECTION

- The cam chain tension adjusters are maintained at the proper cam chain tension automatically.
- Unlock the ratchet (A), and move the push rod in place to see if it slides smoothly. If any stickiness is noted or ratchet mechanism is faulty, replace the cam chain tension adjuster assembly with a new one.

- ① Front cam chain tension adjuster No. 1
- ② Front cam chain tension adjuster No. 2
- ③ Rear cam chain tension adjuster No. 1
- ④ Rear cam chain tension adjuster No. 2

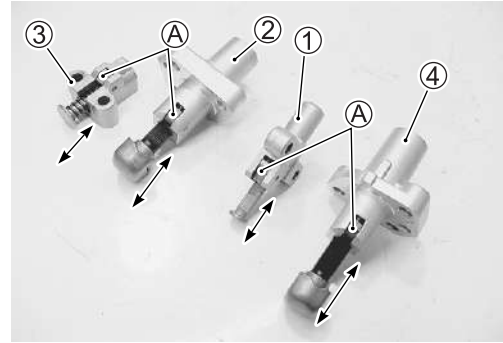

## CAM CHAIN TENSIONER

### INSPECTION

- Check the contacting surface of the cam chain tensioner.
- Check the damage of the cam chain tensioner.
- If it is worn or damaged, replace it with a new one.

- ① Front cam chain tensioner No. 1
- ② Rear cam chain tensioner No. 1

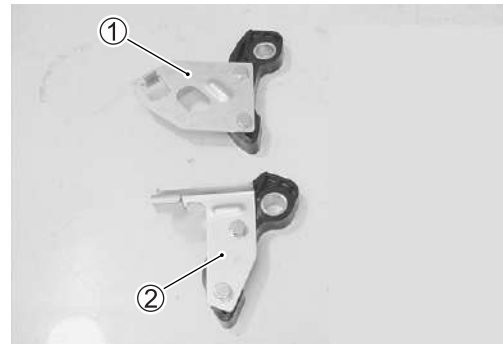

## CAM CHAIN GUIDE

### INSPECTION

- Check the contacting surfaces of the cam chain guides.
- If they are worn or damaged, replace them with the new ones.



## CYLINDER HEAD AND VALVE

### CAM CHAIN TENSIONER

- Remove the cam chain tensioner ①.

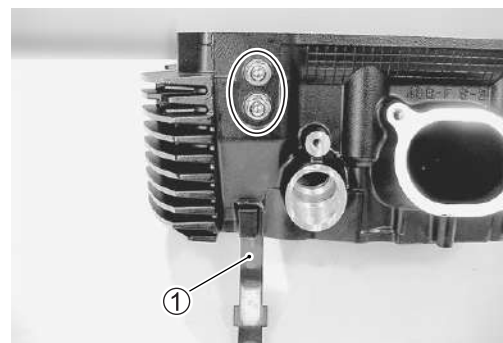



### CYLINDER HEAD DISTORTION

- Decarbonize the combustion chambers.
- Check the gasketed surface of the cylinder head for distortion with a straightedge and thickness gauge, taking a clearance reading at several places indicated.
- If the largest reading at any position of the straightedge exceeds the limit, replace the cylinder head.



#### Cylinder head distortion:

**Service Limit: 0.05 mm (0.002 in)**



**09900-20803: Thickness gauge**

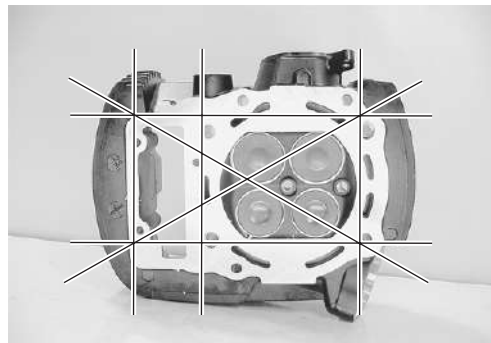

### VALVE AND VALVE SPRING DISASSEMBLY

- Remove the tappet ① and shim ② by fingers or magnetic hand.

#### CAUTION

Identify the position of each removed part.

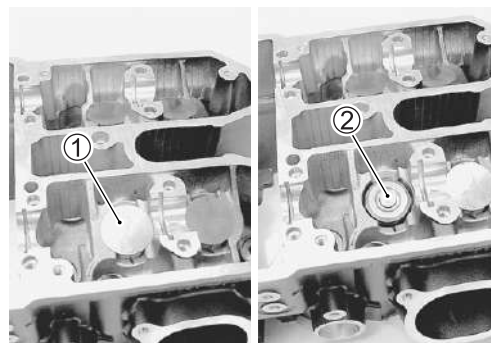

- Install the special tool between the valve spring and cylinder head.



**09919-28610: Sleeve protector.**

#### CAUTION

To prevent damage of the tappet sliding surface with the valve lifter attachment, use a protector.

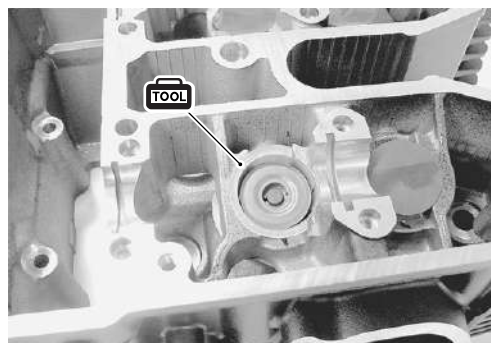

- Using the special tools, compress the valve spring and remove the two cotter halves ③ from the valve stem.



**09916-14510: Valve lifter**

**09916-14910: Valve lifter attachment**

**09916-84511: Tweezers**

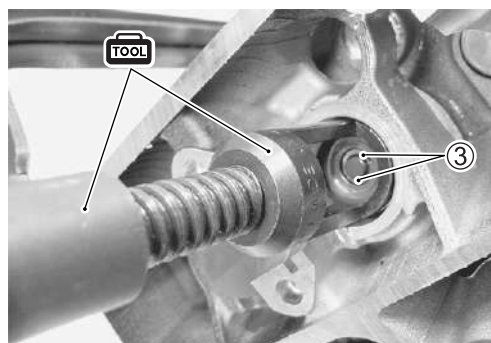

- Remove the valve spring retainer ④ and valve spring ⑤.
- Pull out the valve ⑥ from the combustion chamber side.

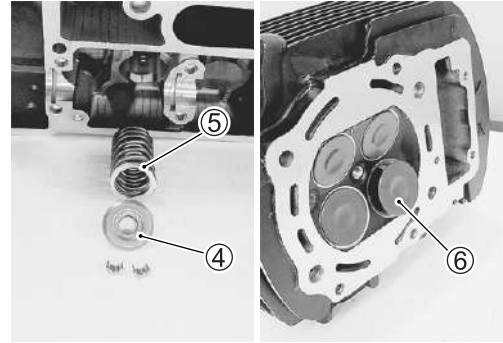

- Remove the oil seal ⑦ and spring seat ⑧.

**CAUTION**

**Do not reuse the removed oil seal.**

- Remove the other valves in the same manner as described previously.

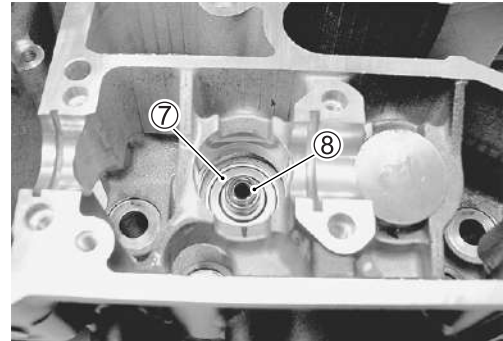

**VALVE STEM RUNOUT**

- Support the valve using V-blocks and check its runout using the dial gauge as shown.
- If the runout exceeds the service limit, replace the valve.

**DATA** Valve stem runout:

Service Limit: 0.05 mm (0.002 in)

- TOOL** 09900-20607: Dial gauge (1/100 mm)
- 09900-20701: Magnetic stand
- 09900-21304: V-block set (100 mm)

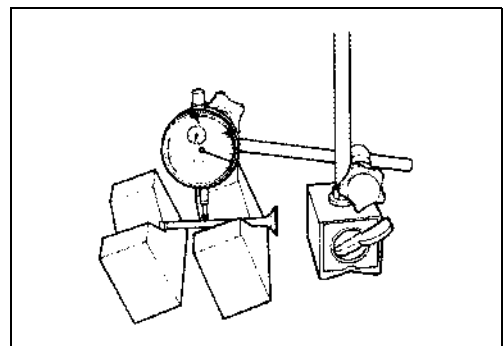

**CAUTION**

**Be careful not to damage the valve and valve stem when handling it.**

**VALVE HEAD RADIAL RUNOUT**

- Place the dial gauge at a right angle to the valve head face and measure the valve head radial runout.
- If it measures more than the service limit, replace the valve.

**DATA** Valve head radial runout:

Service Limit: 0.03 mm (0.001 in)

- TOOL** 09900-20607: Dial gauge (1/100 mm)
- 09900-20701: Magnetic stand
- 09900-21304: V-block set (100 mm)

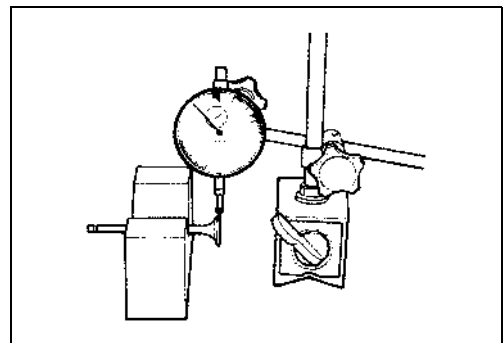

**CAUTION**

**Be careful not to damage the valve and valve stem when handling it.**

### VALVE STEM AND VALVE FACE WEAR CONDITION

- Visually inspect each valve stem and valve face for wear and pitting. If it is worn or damaged, replace the valve with a new one.



### VALVE STEM DEFLECTION

- Lift the valve about 10 mm (0.39 in) from the valve seat.
- Measure the valve stem deflection in two directions, perpendicular to each other, by positioning the dial gauge as shown.
- If the deflection measured exceeds the limit, then determine whether the valve or the guide should be replaced with a new one.

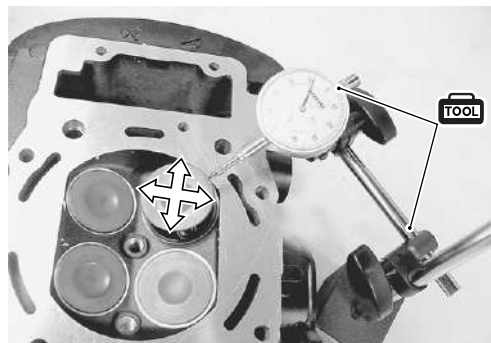

**DATA** Valve stem deflection (IN. & EX.):  
Service Limit: 0.35 mm (0.014 in)

**TOOL** 09900-20607: Dial gauge (1/100 mm)  
09900-20701: Magnetic stand

### VALVE STEM WEAR

- If the valve stem is worn down to the limit, as measured with a micrometer, replace the valve.
- If the stem is within the limit, then replace the guide.
- After replacing valve or guide, be sure to recheck the deflection.

**DATA** Valve stem O.D.:  
Standard (IN.) : 5.975 – 5.990 mm (0.2352 – 0.2358 in)  
(EX.): 5.955 – 5.970 mm (0.2344 – 0.2350 in)

**TOOL** 09900-20205: Micrometer (0 – 25 mm)

#### NOTE:

If valve guides have to be removed for replacement after inspecting related parts, carry out the steps shown in valve guide servicing. (↪ 3-36)

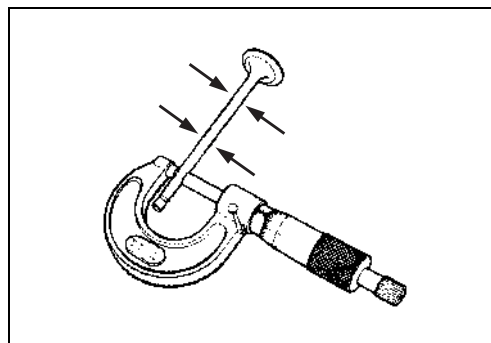

## VALVE GUIDE SERVICING

- Using the valve guide remover, drive the valve guide out toward the intake or exhaust camshaft side.

**TOOL** 09916-46020: Valve guide remover/installer

### NOTE:

- \* Discard the removed valve guide subassemblies.
- \* Only oversized valve guides are available as replacement parts. (Part No. 11115-65J00-001)

- Cool down the new valve guides in a freezer for about one hour and heat the cylinder head to 100 – 150 °C (212 – 302 °F) with a hot plate.

### CAUTION

**Do not use a burner to heat the valve guide hole to prevent cylinder head distortion.**

- Apply engine oil to the valve guide hole.
- Drive the valve guide into the hole using the valve guide installer ① and attachment ②.

**TOOL** 09916-46020: Valve guide installer/remover ①

09916-44940: Attachment ②

### NOTE:

Install the valve guide until the attachment contacts the cylinder head ③.

### CAUTION

**Failure to oil the valve guide hole before driving the new guide into place may result in a damaged guide or head.**

- After installing the valve guides, re-finish their guiding bores using the reamer.
- Clean and oil the guides after reaming.

**TOOL** 09916-37810: Valve guide reamer

09916-34542: Reamer handle

### NOTE:

- \* Be sure to cool down the cylinder head to ambient air temperature.
- \* Insert the reamer from the combustion chamber and always turn the reamer handle clockwise.

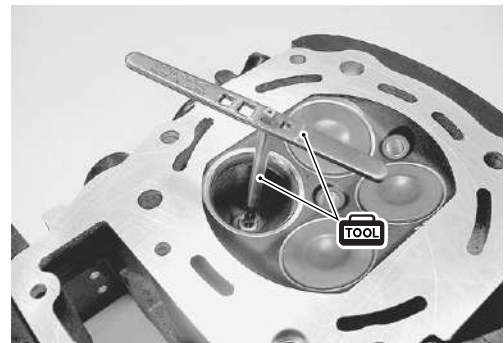
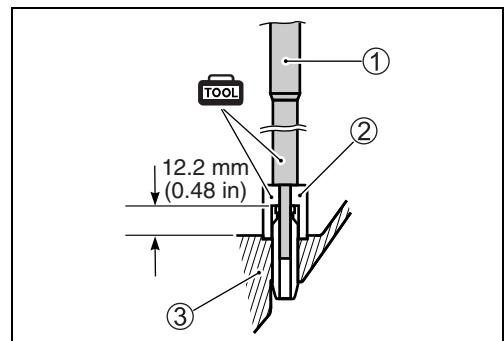
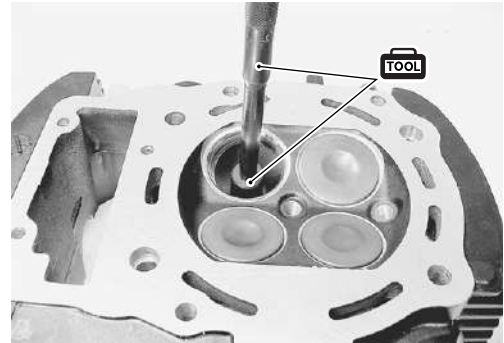
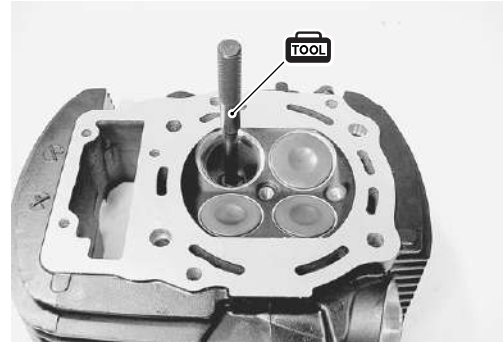

### VALVE SEAT WIDTH INSPECTION

- Visually check for valve seat width on each valve face.
- If the valve face has worn abnormally, replace the valve.
- Coat the valve seat with a red lead (Prussian Blue) and set the valve in place. Rotate the valve with light pressure.
- Check that the transferred red lead (blue) on the valve face is uniform all around and in center of the valve face.

#### 09916-10911: Valve lapper set

- If the seat width  $\text{\textcircled{W}}$  measured exceeds the standard value or seat width is not uniform, reface the seat using the seat cutter.

#### **Valve seat width $\text{\textcircled{W}}$ :**

**Standard: (IN.): 1.1 – 1.3 mm (0.043 – 0.051 in)**  
**(EX.): 1.4 – 1.6 mm (0.055 – 0.063 in)**

If the valve seat is out of specification, re-cut the seat.

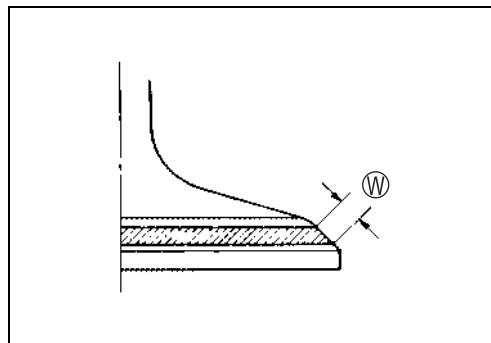
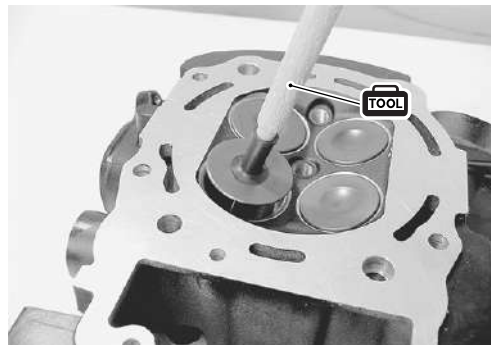

### VALVE SEAT SERVICING

- The valve seats ① for both the intake valve ② and exhaust valve ③ are machined to three different angles. The seat contact surface is cut at 45°.

	INTAKE	EXHAUST
Seat angle	15°, 45°, 60°	←
Seat width	1.1 – 1.3 mm (0.043 – 0.051 in)	1.4 – 1.6 mm (0.055 – 0.063 in)
Valve diameter	42 mm (1.65 in)	38 mm (1.50 in)
Valve guide I.D.	6.000 – 6.012 mm (0.2362 – 0.2377 in)	←

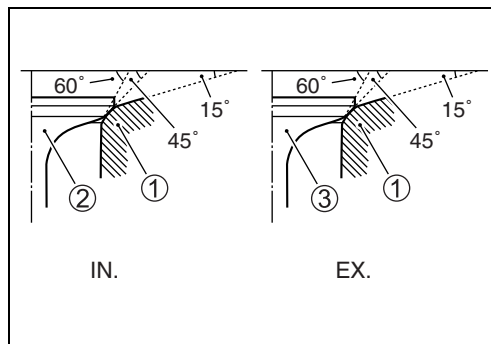

#### **CAUTION**

- \* The valve seat contact area must be inspected after each cut.
- \* Do not use lapping compound after the final cut is made. The finished valve seat should have a velvety smooth finish but not a highly polished or shiny finish. This will provide a soft surface for the final seating of the valve which will occur during the first few seconds of engine operation.

#### NOTE:

After servicing the valve seats, be sure to check the valve clearance after the cylinder head has been reinstalled. (↗ 2-8)



- Clean and assemble the head and valve components. Fill the intake and exhaust ports with gasoline to check for leaks.
- If any leaks occur, inspect the valve seat and face for burrs or other things that could prevent the valve from sealing.

**⚠ WARNING**

**Always use extreme caution when handling gasoline.**



**VALVE SPRING**

The force of the coil spring keeps the valve seat tight. Weakened spring results in reduced engine power output, and often accounts for the chattering noise coming from the valve mechanism.

- Check the valve spring for proper strength by measuring its free length and also by the force required to compress it.
- If the spring length is less than the service limit, or if the force required to compress the spring does not fall within the range specified, replace the spring.

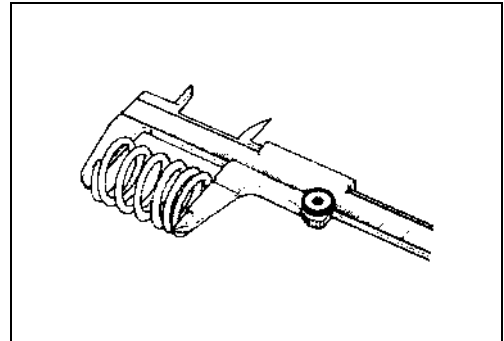

**DATA** Valve spring free length:

Service limit: (IN. & EX.): 40.5 mm (1.60 in)

**TOOL** 09900-20102: Vernier calipers

**DATA** Valve spring tension (IN. & EX.):

Standard: 197 – 227 N

(20.1 – 23.1 kgf/36.6 mm, 44.3 – 51.0 lbs/1.44 in)

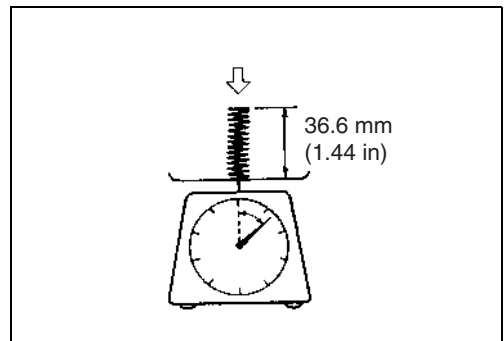

**VALVE AND VALVE SPRING REASSEMBLY**

- Install the valve spring seat ①.
- Apply MOLYBDENUM OIL SOLUTION to the oil seal ②, and press-fit it into position.

**MOLYBDENUM OIL SOLUTION**

**CAUTION**

**Do not reuse the removed oil seal.**

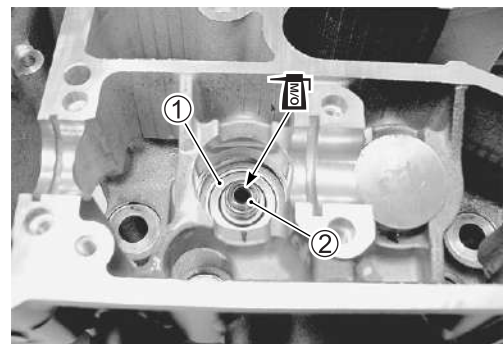

- Insert the valve, with its stem coated with MOLYBDENUM OIL SOLUTION all around and along the full stem length without any break.

**CAUTION**

**When inserting the valve, take care not to damage the lip of the oil seal.**

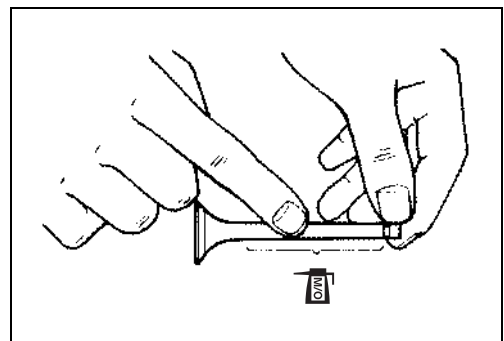

**MOLYBDENUM OIL SOLUTION**

- Install the valve spring with the small-pitch portion (A) facing cylinder head.

- Ⓑ Large-pitch portion
- Ⓒ UPWARD
- Ⓓ Paint

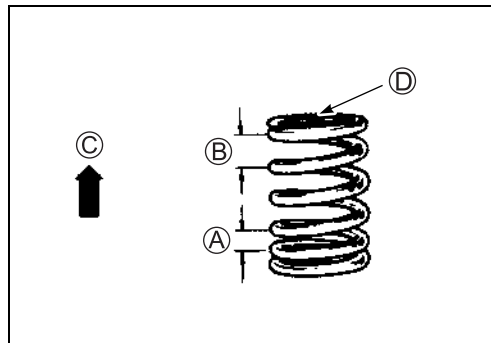

- Put on the valve spring retainer (3), and using the valve lifter and protector (4), press down the spring, fit the cotter halves to the stem end, and release the lifter to allow the cotter (5) to wedge in between retainer and stem.

- TOOL** 09916-14510: Valve lifter
- 09916-14910: Valve lifter attachment
- 09916-84511: Tweezers
- 09919-28610: Sleeve protector

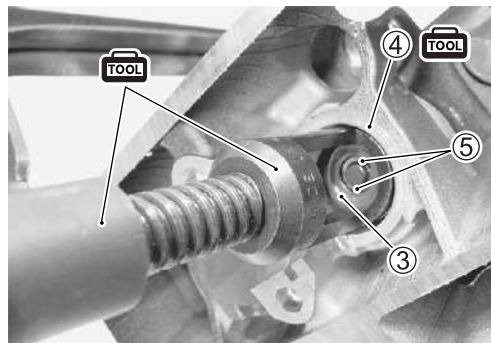

- Be sure that the rounded lip (E) of the cotter fits snugly into the groove (F) in the stem end.
- Install the other valves and springs in the same manner as described previously.

- Ⓓ Valve spring retainer
- Ⓔ Cotter

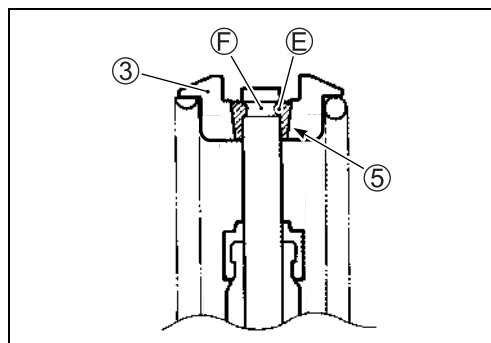
**CAUTION**

Be sure to restore each spring and valve to their original positions.

**CAUTION**

Be careful not to damage the valve and valve stem when handling it.

- Install the tappet shims and the tappets to their original positions.

**NOTE:**

- \* Apply engine oil to the stem end, shim and tappet before fitting them.
- \* When seating the tappet shim, be sure the figure printed surface faces the tappet.

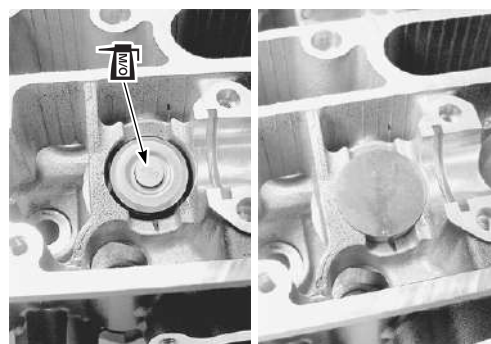



**CAM CHAIN TENSIONER**

- Inspect the cam chain tensioner for damage. If any damage are found, replace the cam chain tensioner with a new one.



- Install the cam chain tensioner ①, washers ② and nuts ③.
- Tighten the cam chain tensioner nuts to the specified torque.

 **Cam chain tensioner nut: 10 N·m (1.0 kgf·m, 7.0 lb·ft)**

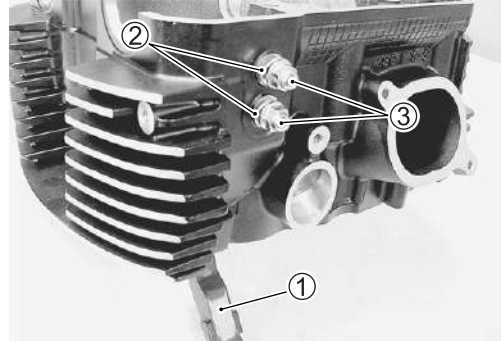
**WATER JACKET PLUG**

- Remove the water jacket plug ①.

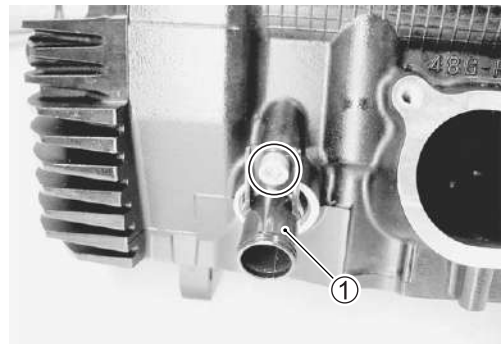

- Apply engine coolant to the new O-ring and install the water jacket plug.

**CAUTION**

**Use a new O-ring to prevent engine coolant leakage.**

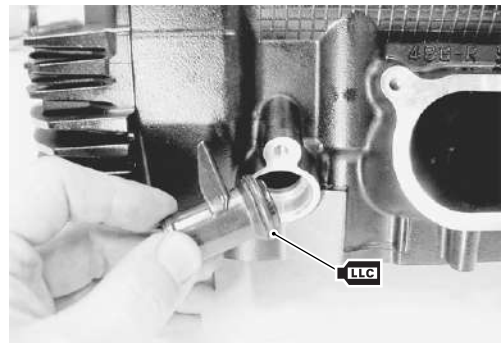

## CYLINDER

### CYLINDER DISTORTION

- Check the gasketed surface of the cylinder for distortion with a straightedge and thickness gauge, taking a clearance reading at several places as indicated.
- If the largest reading at any position of the straightedge exceeds the limit, replace the cylinder.

**DATA** Cylinder distortion:  
Service Limit: 0.05 mm (0.002 in)

**TOOL** 09900-20803: Thickness gauge

### CYLINDER BORE

- Inspect the cylinder wall for any scratches, nicks or other damage.

**DATA** Cylinder bore:  
Standard: 112.000 – 112.015 mm (4.4094 – 4.4100 in)

### CAM CHAIN GUIDE

- Inspect the cam chain guide for damage. If any damage are found, replace the cam chain guide with a new one.

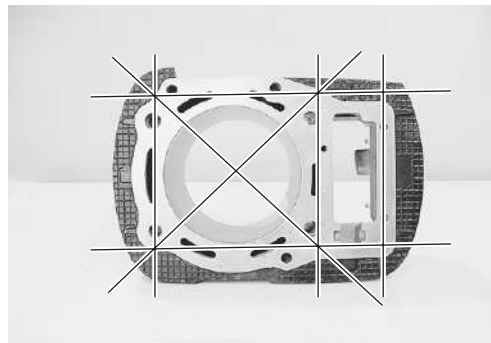

## PISTON AND PISTON RING

### PISTON DIAMETER

- Using a micrometer, measure the piston diameter at 10 mm (0.4 in)  $\text{\textcircled{A}}$  from the piston skirt end.
- If the measurement is less than the limit, replace the piston.

#### **DATA** Piston diameter:

**Service Limit: 111.880 mm (4.4047 in)**  
**at 10 mm (0.4 in) from the skirt end**

**TOOL** 09900-20210: Micrometer (100 – 125 mm)

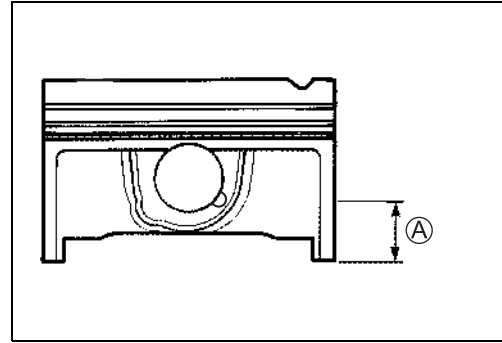

### PISTON-TO-CYLINDER CLEARANCE

- Subtract the piston diameter from the cylinder bore diameter. (↪ 3-41)
- If the piston-to-cylinder clearance exceeds the service limit, replace the cylinder or the piston, or both.

#### **DATA** Piston-to-cylinder clearance:

**Service Limit: 0.120 mm (0.0047 in)**

### PISTON PIN AND PIN BORE

- Measure the piston pin bore diameter using the small bore gauge.
- If the measurement is out of specification, replace the piston.

#### **DATA** Piston pin bore I.D.:

**Service Limit: 23.030 mm (0.9067 in)**

**TOOL** 09900-20602: Dial gauge (1/1000 mm)  
 09900-22403: Small bore gauge (18 – 35 mm)

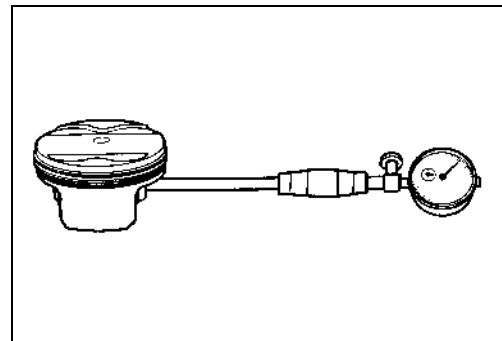

- Measure the piston pin outside diameter at three positions using the micrometer.
- If any of the measurements is out of specification, replace the piston pin.

#### **DATA** Piston pin O.D.:

**Service Limit: 22.980 mm (0.9047 in)**

**TOOL** 09900-20205: Micrometer (0 – 25 mm)

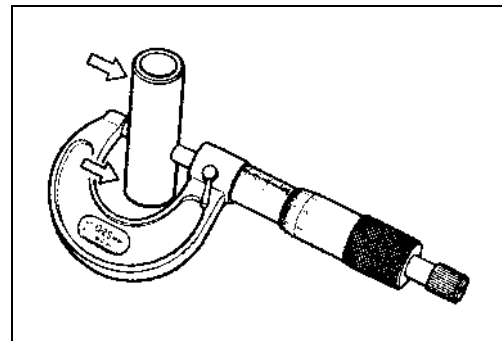

**PISTON RING-TO-GROOVE CLEARANCE**

- Measure the side clearances of the 1st and 2nd piston rings using the thickness gauge.
- If any of the clearances exceeds the limit, replace both the piston and piston rings.

**TOOL** 09900-20803: Thickness gauge  
09900-20205: Micrometer (0 – 25 mm)

**DATA** Piston ring-to-groove clearance:  
Service Limit (1st) : 0.180 mm (0.0071 in)  
(2nd): 0.150 mm (0.0059 in)

**DATA** Piston ring groove width:  
Standard (1st) : 0.93 – 0.95 mm (0.0366 – 0.0374 in)  
: 1.55 – 1.57 mm (0.0610 – 0.0618 in)  
(2nd): 1.21 – 1.23 mm (0.0476 – 0.0484 in)  
(Oil) : 2.51 – 2.53 mm (0.0988 – 0.0996 in)

**DATA** Piston ring thickness:  
Standard (1st) : 0.86 – 0.91 mm (0.034 – 0.036 in)  
: 1.38 – 1.40 mm (0.054 – 0.055 in)  
(2nd): 1.17 – 1.19 mm (0.046 – 0.047 in)

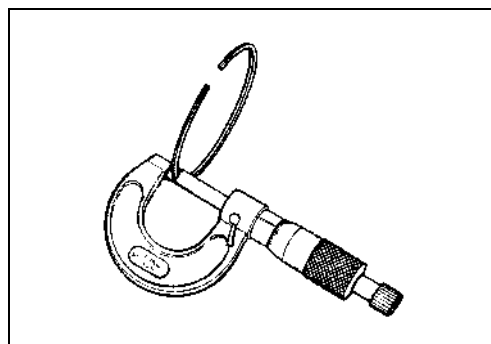
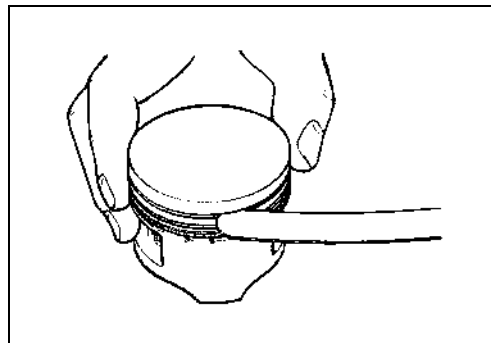
**PISTON RING FREE END GAP AND PISTON RING END GAP**

- Measure the piston ring free end gap using the vernier calipers.
- Next, fit the piston ring squarely into the cylinder and measure the piston ring end gap using the thickness gauge.
- If any of the measurements exceeds the service limit, replace the piston ring with a new one.

**DATA** Piston ring free end gap:  
Service Limit (1st) : 12.6 mm (0.50 in)  
(2nd): 11.6 mm (0.46 in)

**TOOL** 09900-20101: Vernier calipers

**DATA** Piston ring end gap:  
Service Limit (1st) : 0.50 mm (0.020 in)  
(2nd): 0.50 mm (0.020 in)

**TOOL** 09900-20803: Thickness gauge

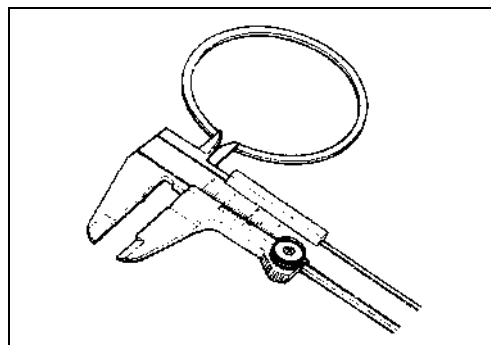

## CLUTCH

### CLUTCH PLATE THICKNESS

#### NOTE:

Wipe off engine oil from the clutch plates with a clean rag.

- Measure the thickness of drive and driven plates with a vernier calipers. If each plate is not within the service limit or standard range, replace it with a new one.

#### **DATA** Drive plate thickness

Service limit (No. 1): 3.22 mm (0.127 in)

Standard (No. 2): 1.92 – 2.08 mm (0.076 – 0.082 in)

#### **DATA** Driven plate thickness

Service limit (No. 2): 3.17 mm (0.125 in)

Standard (No. 1): 2.82 – 2.98 mm (0.111 – 0.117 in)

#### **TOOL** 09900-20102: Vernier calipers

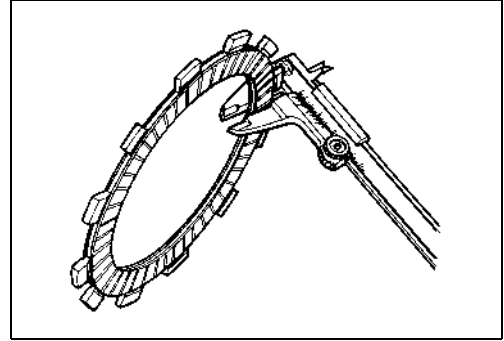

### DRIVEN PLATE CLAW WIDTH

- Measure the claw width of driven plates with a vernier calipers.
- Replace the driven plates found to have worn down to the limit.

#### **DATA** Driven plate claw width

Service limit (No. 1 & No. 2): 7.16 mm (0.282 in)

#### **TOOL** 09900-20102: Vernier calipers

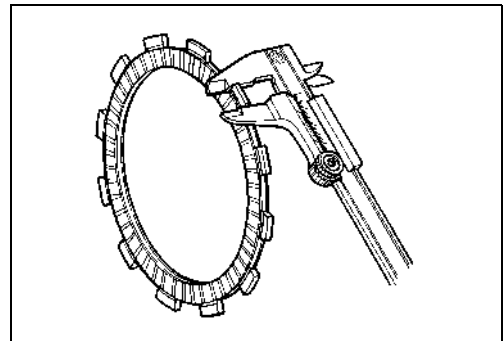

### CLUTCH PLATE DISTORTION

#### NOTE:

Wipe off engine oil from the clutch drive and driven plates with a clean rag.

- Measure each clutch plate for distortion with a thickness gauge and surface plate.
- Replace clutch plates which exceed the limit.

#### **DATA** Clutch plate distortion

(drive plate No. 2 and driven plate No. 1)

Service Limit: 0.10 mm (0.004 in)

#### **TOOL** 09900-20803: Thickness gauge

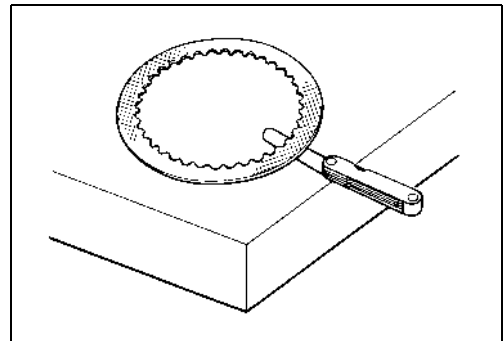

### CLUTCH SPRING FREE LENGTH

- Measure the free length of each coil spring with a vernier calipers, and compare the length with the specified limit. Replace all the springs if any spring is not within the limit.

#### **DATA** Clutch spring free length

Service Limit: 48.8 mm (1.92 in)

#### **TOOL** 09900-20102: Vernier calipers

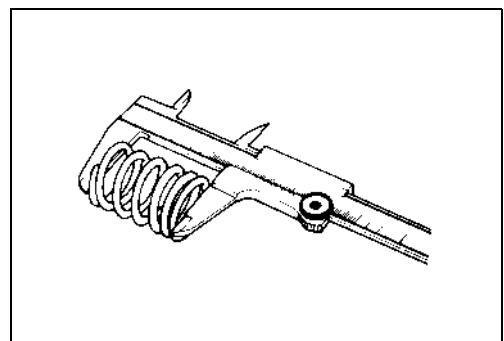

**CLUTCH RELEASE BEARING**

- Inspect the clutch release bearing for any abnormality, particularly cracks, to decide whether it can be reused or should be replaced.
- Smooth engagement and disengagement of the clutch depends on the condition of this bearing.

**CLUTCH PUSH ROD**

- Inspect the clutch push rod for damage and bend. If necessary, replace it with a new one.

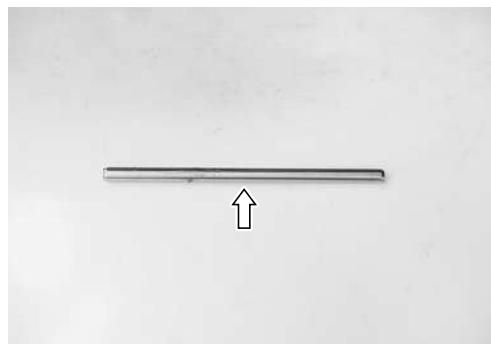
**CLUTCH PUSH ROD RELEASE BALL**

- Inspect the push rod release ball for damage or wear. If necessary, replace it with a new one.

**CLUTCH SLEEVE HUB/PRIMARY DRIVEN GEAR ASSEMBLY**

- Inspect the slot of the clutch sleeve hub and primary driven gear assembly for damage or wear caused by the clutch plates. If necessary, replace it with a new one.

**CAUTION**

**Do not attempt to disassemble the primary driven gear assembly. They are unserviceable.**



### PRIMARY DRIVE GEAR BEARING

- Inspect the needle bearing for abnormal noise, wear and damage. If necessary, replace it with a new one.



### GEARSHIFT COVER

#### DISASSEMBLY

- Remove the gearshift shaft oil seal ①.



- Remove the bearing with the special tools.

- TOOL 09921-20210: Bearing remover  
 09930-30104: Sliding shaft

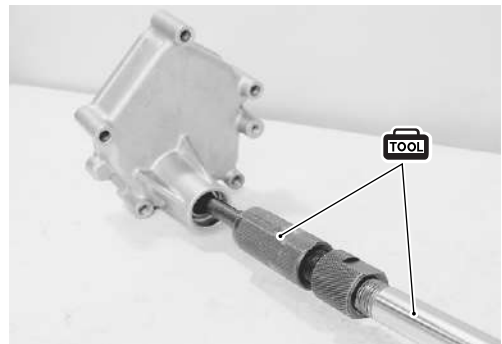

#### REASSEMBLY

- Install the bearing ① and oil seal ② with the special tool.

- TOOL 09913-70210: Bearing installer set (22 mm)

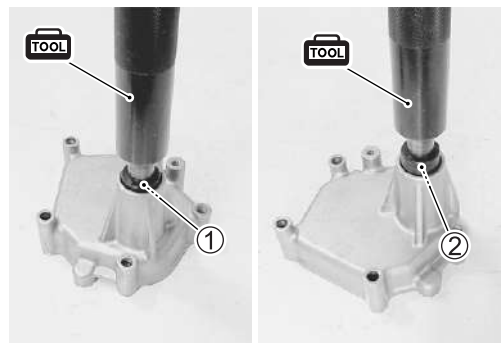

- Apply SUZUKI SUPER GREASE “A” to the oil seal lip.

- A 99000-25010: SUZUKI SUPER GREASE “A”  
 or equivalent



#### CAUTION

Use a new oil seal to prevent oil leakage.



## STARTER CLUTCH

### STARTER DRIVEN GEAR INSPECTION

- Turn the starter driven gear by hand.
- Inspect the starter clutch for a smooth movement.
- Check that the gear turns only in one direction.

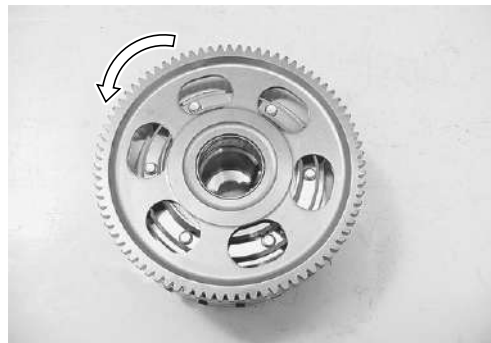

- Inspect the starter driven gear bushing for any damage. If necessary, replace it with a new one.



### DISASSEMBLY

- Remove the starter clutch securing bolts.



- Remove the one way clutch ① and guide ② from the generator rotor.

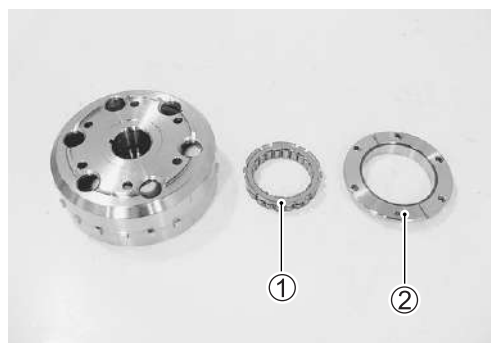

### REASSEMBLY

- Install the starter clutch in the proper direction.

#### NOTE:

When installing the one way clutch to the guide, face the flange side Ⓐ of the one way clutch to the rotor.

- Apply engine oil to the starter clutch.



- Apply THREAD LOCK SUPER to the bolts, and then tighten them to the specified torque.

 **Starter clutch bolt: 25 N·m (2.5 kgf·m, 18.0 lb·ft)**

 **99000-32030: THREAD LOCK SUPER “1303”**  
or equivalent

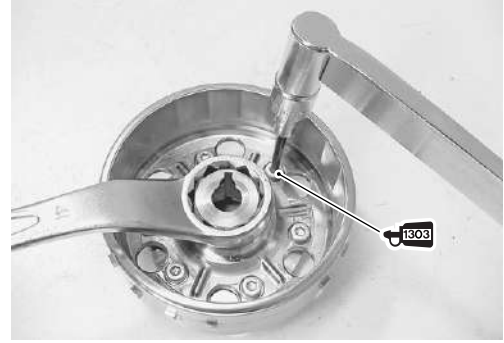

## OIL PUMP

### REMOVAL

- Remove the oil pump assembly ① with oil return pump.

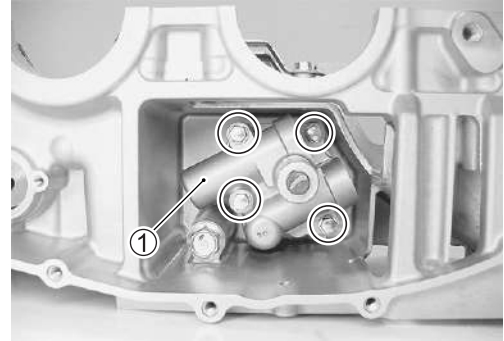

### DISASSEMBLY

- Remove the oil return pump outer rotor ①, inner rotor ② and pin ③.

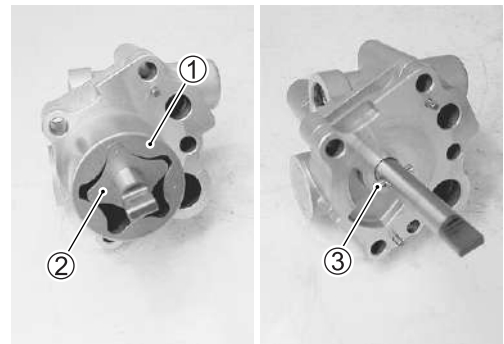

### INSPECTION

- Rotate the oil pump by hand and check that it moves smoothly.
- If it does not move smoothly, replace the oil pump assembly.

### CAUTION

- \* Do not attempt to disassemble the oil pump assembly.
- \* The oil pump is available only as an assembly.



- Inspect the outer rotor ① and inner rotor ② for any scratches or other damage. If any damages are found, replace them with new ones.

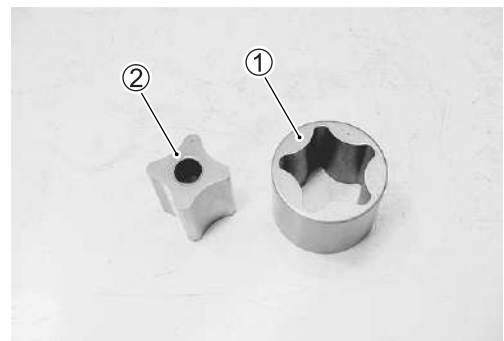

**REASSEMBLY**

- Apply engine oil to the sliding surfaces of the oil pump inner rotor, outer rotor and shaft.
- When installing the inner rotor ①, align the pin ② with the groove ③.

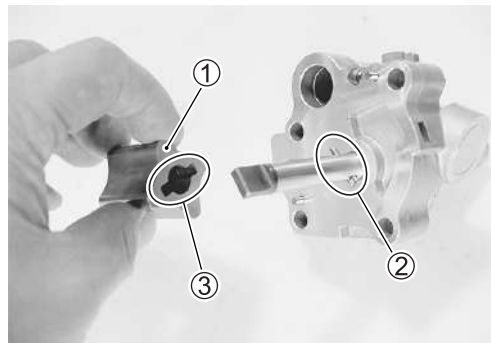

- When installing the inner rotor and outer rotor, face the punched marks (A) on the rotors to the outside.

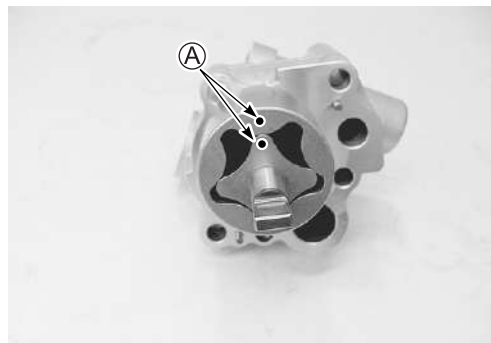
**INSTALLATION**

- Before mounting the oil pump, apply engine oil to the sliding surfaces of the outer rotor, inner rotor, and shaft.

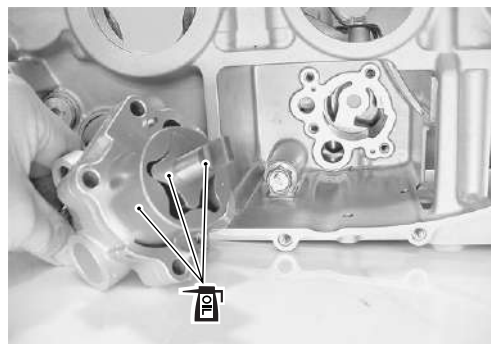

- Tighten the oil pump mounting bolts.

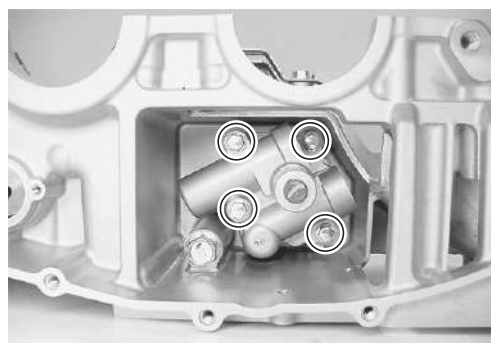

## STARTER TORQUE LIMITER

### STARTER TORQUE LIMITER INSPECTION

#### CAUTION

- \* Do not attempt to disassemble the starter torque limiter.
- \* The starter torque limiter is available only as an assembly.

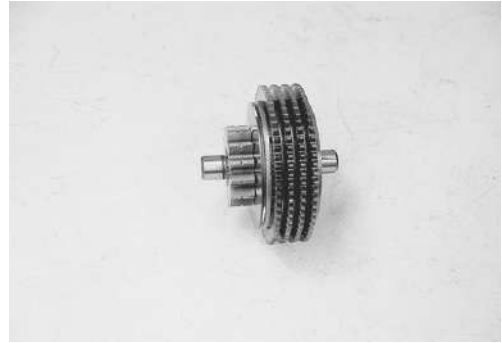

- Check the slip torque with the special tools.

#### DATA Slip torque

Standard: 31 – 51 N·m (3.1 – 5.1 kgf·m, 22.5 – 37.0 lb-ft)

-  09930-73170: Starter torque limiter holder
- 09930-73180: Starter torque limiter socket

- Set the starter torque limiter to the special tools and vise as shown.
- If the slip torque is not within the specification, replace the starter torque limiter with a new one.

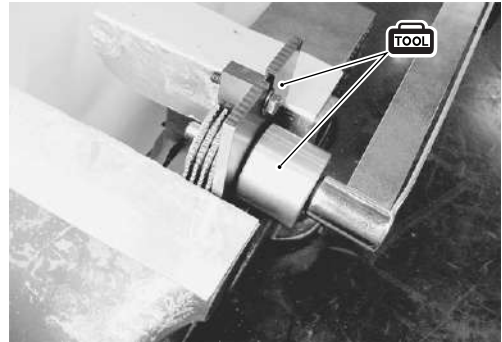

## GENERATOR COVER

### GENERATOR INSPECTION (👉 10-10)

#### REASSEMBLY

- Apply a small quantity of THREAD LOCK to the stator bolt.
- Tighten the generator stator bolts ①, clamp bolt ② and CKP sensor bolts ③.

-  99000-32050: THREAD LOCK "1342" or equivalent

-  Generator stator bolt ①: 11 N·m (1.1 kgf·m, 8.0 lb-ft)
- CKP sensor bolt ③: 6.5 N·m (0.65 kgf·m, 4.5 lb-ft)

#### NOTE:

Be sure to install the grommet (A) to the generator cover.

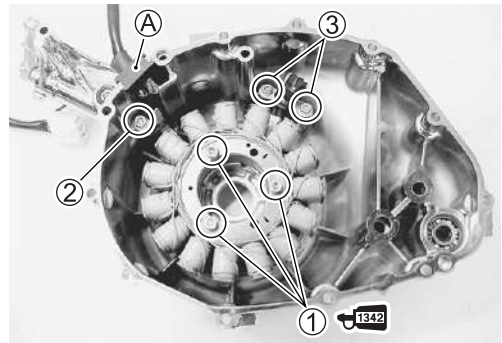

#### BEARING INSPECTION

- Inspect the starter motor shaft bearing for abnormal noise and smooth rotation while they are in the generator cover.
- Replace the bearing if there is anything unusual.

#### BEARING REMOVAL

- Remove the snap ring ① and bearing ②.

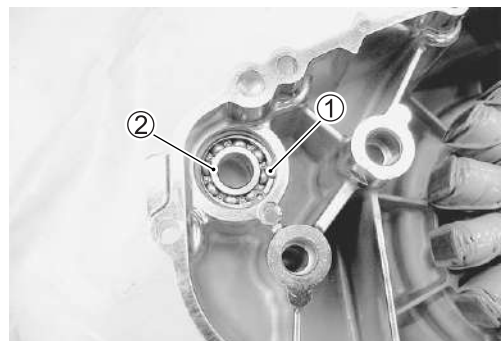

## CLUTCH RELEASE CAMSHAFT

### DISASSEMBLY

- Remove the clutch release arm ①, return spring ② and washer ③.

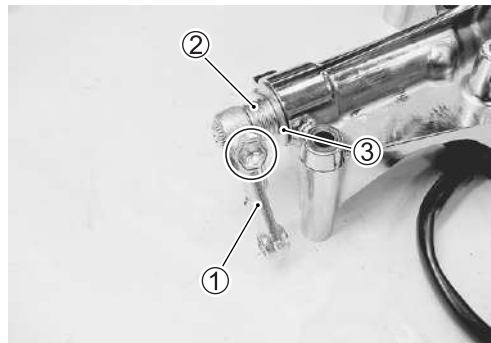

- Pull out the oil seal ④, bearing ⑤ with the clutch release camshaft ⑥.

### CAUTION

The removed oil seal and bearing must be replaced with new one.

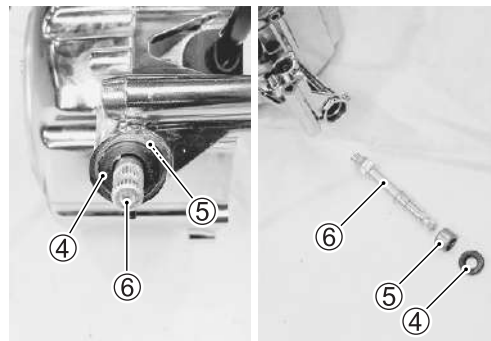

- Remove the clutch push rod cap ⑦ and oil seal ⑧.

### CAUTION

The removed oil seal must be replaced with new one.

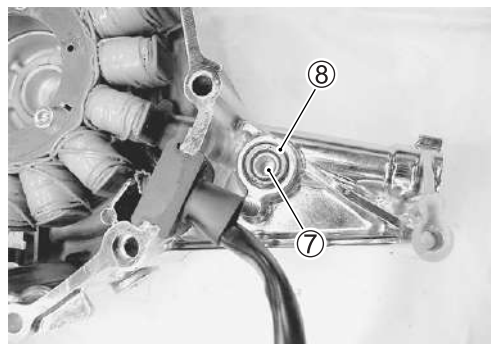

### REASSEMBLY

- Apply SUZUKI SUPER GREASE "A" the release camshaft ①, new bearing ② and oil seal ③ before installing.

 99000-25010: SUZUKI SUPER GREASE "A"  
or equivalent

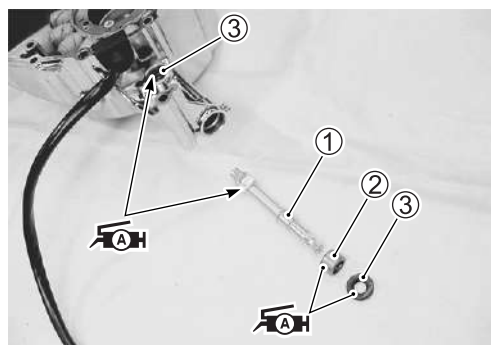

- Install the clutch release arm and tighten the bolt ①.

### NOTE:

Align the release arm punch mark (A) with the notch mark (B) on the release camshaft.

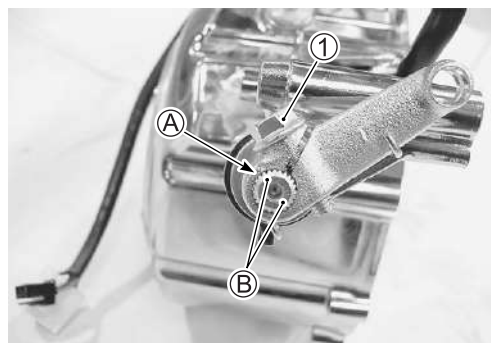

## WATER PUMP

8-15

## GEARSHIFT

### GEARSHIFT SHAFT/GEARSHIFT ARM DISASSEMBLY

- Remove the following parts from the gearshift shaft/gearshift arm.

- |                                 |                             |
|---------------------------------|-----------------------------|
| ① Washer                        | ④ Gearshift cam drive plate |
| ② Snap ring                     | ⑤ Plate return spring       |
| ③ Gearshift shaft return spring |                             |

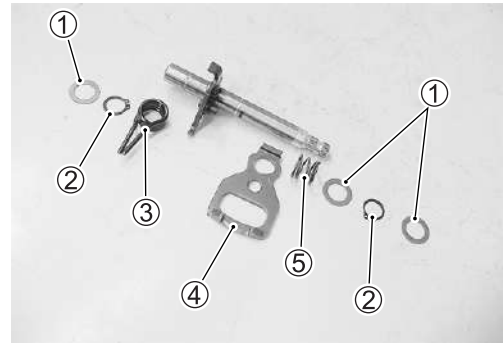

### GEARSHIFT SHAFT/GEARSHIFT ARM INSPECTION

- Inspect the gearshift shaft/gearshift arm for wear or bend.
- Inspect the return springs for damage or fatigue.
- Replace the arm or spring if there is anything unusual.

### GEARSHIFT SHAFT/GEARSHIFT ARM REASSEMBLY

- Install the following parts to the gearshift shaft/gearshift arm as shown in the illustration.

- |                                 |                             |
|---------------------------------|-----------------------------|
| ① Washer                        | ④ Gearshift cam drive plate |
| ② Snap ring                     | ⑤ Plate return spring       |
| ③ Gearshift shaft return spring |                             |

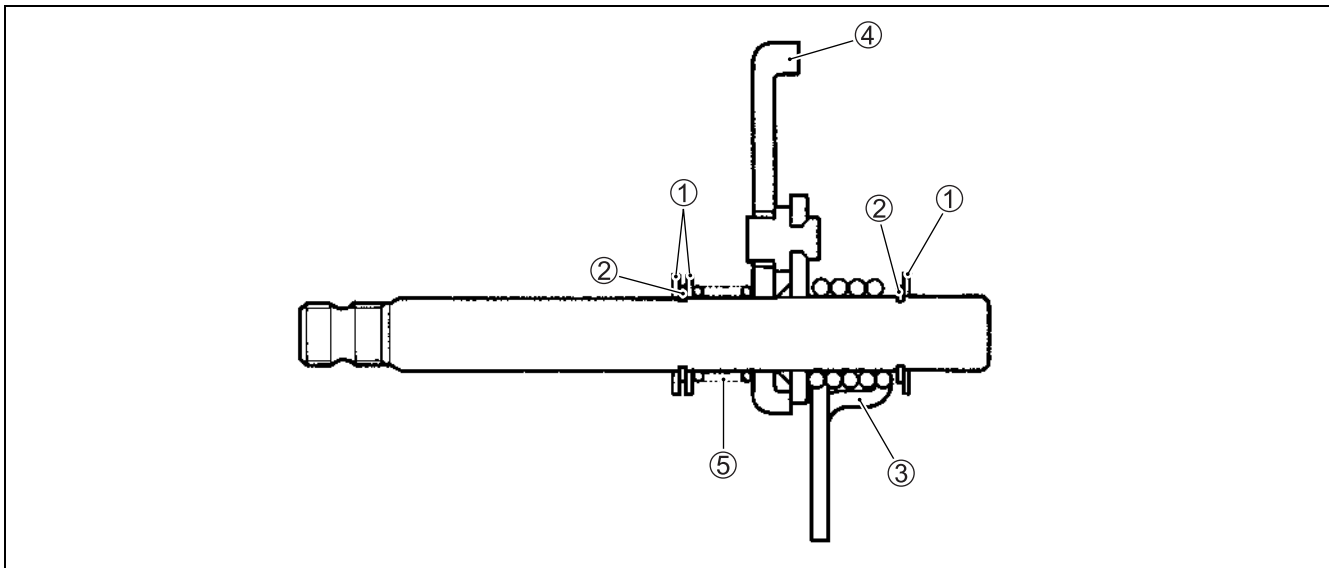

#### NOTE:

When installing the gearshift shaft return spring, position the stopper (A) of gearshift arm between the shaft return spring ends (B).

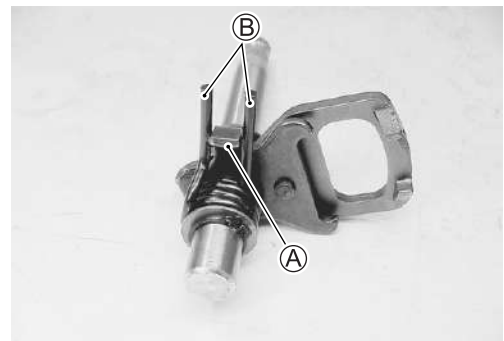



## OIL PRESSURE REGULATOR

- Inspect the operation of the oil pressure regulator by pushing on the piston with a proper bar.
- If the piston does not operate, replace the oil pressure regulator with a new one.

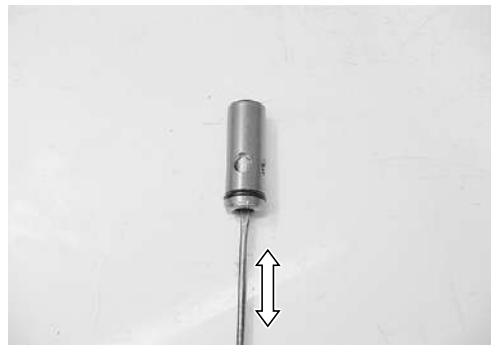

## OIL STRAINER

- Clean the oil strainer if necessary.
- Inspect the oil strainer body for damage. If necessary, replace it with a new one.



## TRANSMISSION CONSTRUCTION

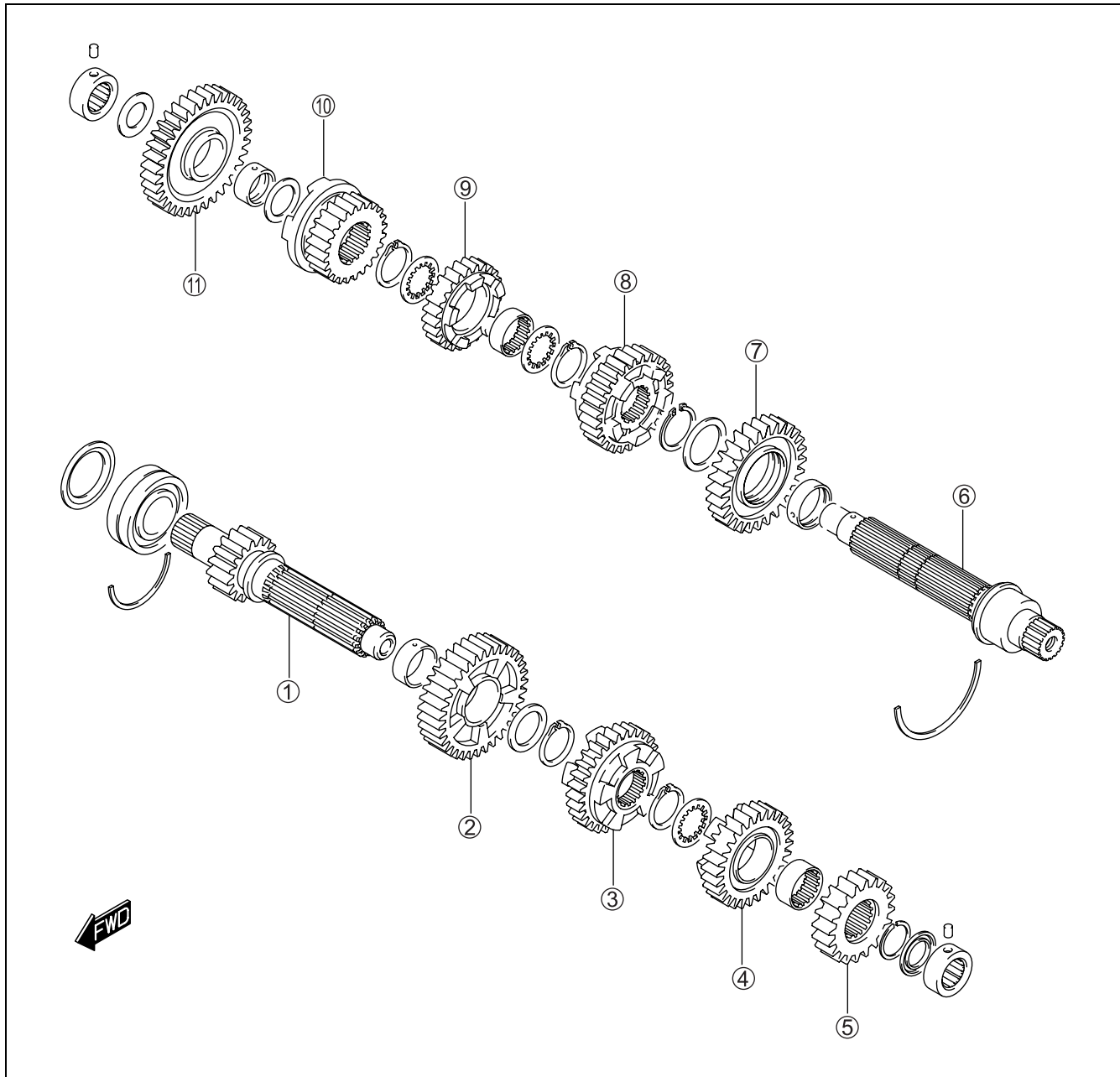

①	Countershaft/1st drive gear	⑦	2nd driven gear
②	5th drive gear	⑧	3rd driven gear
③	4th drive gear	⑨	4th driven gear
④	3rd drive gear	⑩	5th driven gear
⑤	2nd drive gear	⑪	1st driven gear
⑥	Driveshaft		

**DISASSEMBLY****CAUTION**

Be sure to identify each removed part as to its location, and lay the parts out in groups designated as “Drive” and “Driven”, so that each will be restored to the original location during assembly.

**Countershaft**

- Remove the bearing ① and oil seal ②.
- Open the 3rd drive gear snap ring ③ from its groove and slide it towards the 4th drive gear ④ side.
- Slide the 3rd ⑤ and 2nd ⑥ drive gears toward the 4th drive gear ④ side then remove the 2nd drive gear circlip ⑦.

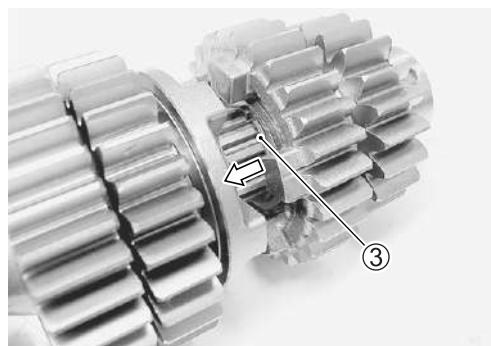
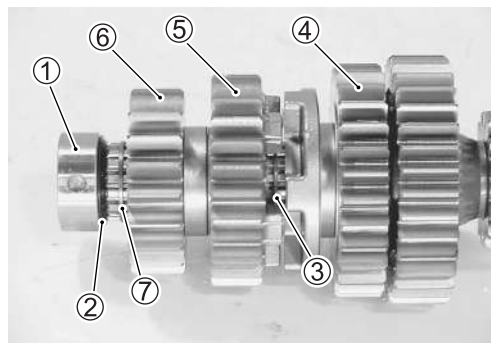

- Remove the 2nd drive gear ⑧ and 3rd drive gear ⑨.

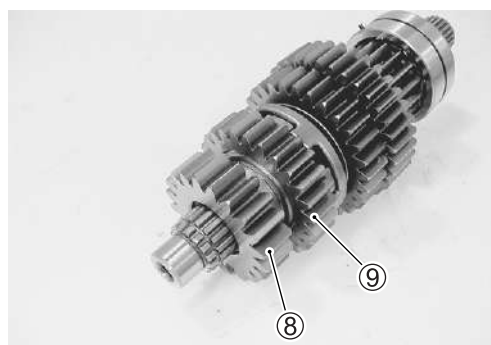

- Remove the 3rd drive gear bushing ⑩, washer ⑪, snap ring ⑫ and 4th drive gear ⑬.

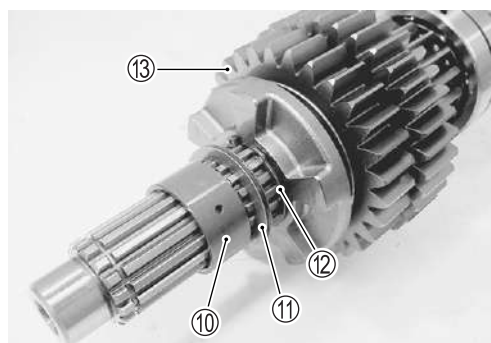

- Remove the snap ring ⑭, washer ⑮, 5th drive gear ⑯ and 5th drive gear bushing ⑰.

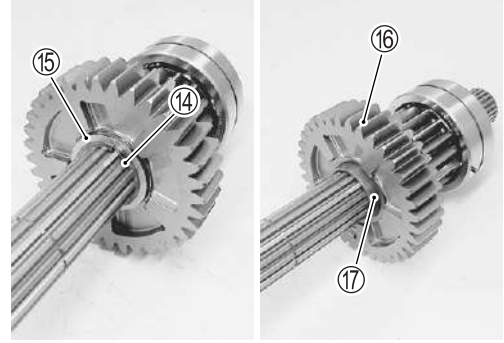

**Driveshaft**

- Remove the bearing ①, washer ② and 1st driven gear ③.

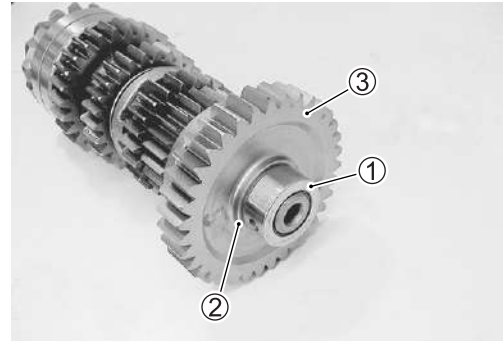

- Remove the 1st driven gear bushing ④, washer ⑤ and 5th driven gear ⑥.

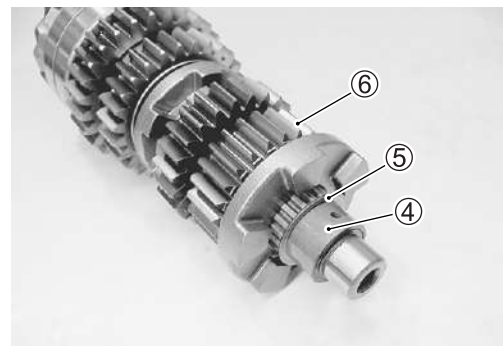

- Remove the snap ring ⑦, washer ⑧ and 4th driven gear ⑨.

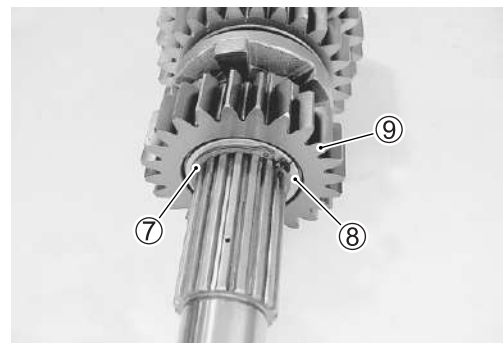

- Remove the 4th driven gear bushing ⑩, washer ⑪, snap ring ⑫ and 3rd driven gear ⑬.

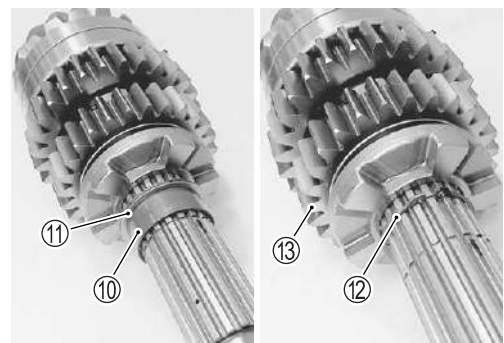

- Remove the snap ring ⑭, washer ⑮, 2nd driven gear ⑯ and its bushing.
- Remove the secondary drive gear with the bearing ⑰.

**CAUTION**

- \* Do not attempt to disassemble the secondary drive gear and bearing assembly.
- \* The secondary drive gear and bearing is available only as an assembly.

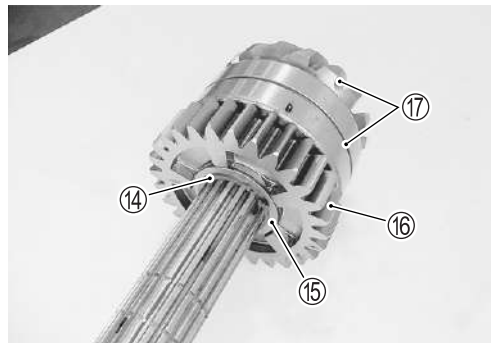
**REASSEMBLY**

Assemble the countershaft and driveshaft in the reverse order of disassembly. Pay attention to the following points:

**NOTE:**

- \* Rotate the bearings by hand to inspect for smooth rotation. Replace the bearings if there is anything unusual.
- \* Before installing the gears, apply engine oil to the driveshaft and countershaft.
- \* When installing the oil seal, apply SUZUKI SUPER GREASE "A" to it.

 99000-25010: SUZUKI SUPER GREASE "A" or equivalent

**CAUTION**

- \* Never reuse a snap ring. After a snap ring has been removed from a shaft, it should be discarded and a new snap ring must be installed.
- \* When installing a new snap ring, do not expand the end gap larger than required to slip the snap ring over the shaft.
- \* After installing a snap ring, make sure that it is completely seated in its groove and securely fitted.

**NOTE:**

When reassembling the transmission, attention must be given to the locations and positions of washers and snap rings. The cross sectional view shows the correct position of the gears, bushings, washers and snap rings. (3-59)

- When installing a new snap ring, pay attention to its direction.  
Fit it to the side where the thrust is as shown in the illustration.

- Ⓐ Thrust
- Ⓑ Sharp edge

**CAUTION**

When installing the gear bushing onto the countershaft ① and driveshaft ②, align the shaft oil hole ③ with the 3rd drive gear bushing oil hole ④ and 4th driven gear bushing oil hole ⑤.

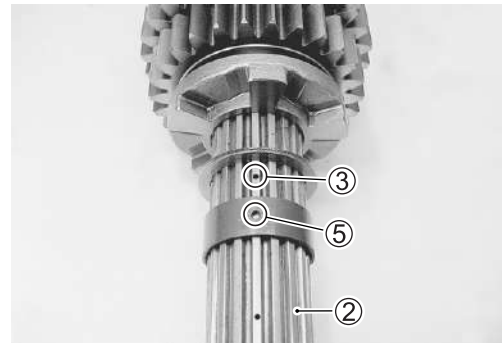
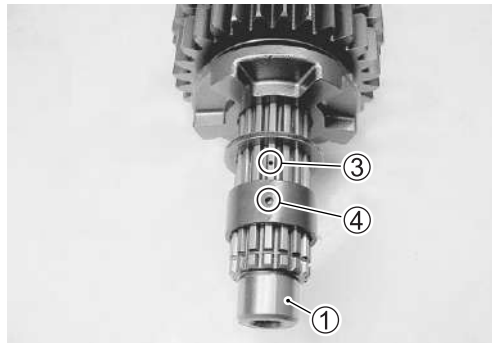
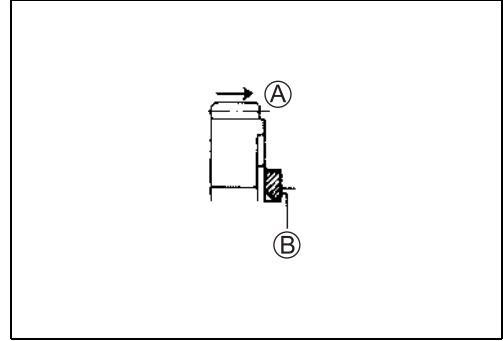



## TRANSMISSION PARTS LOCATION

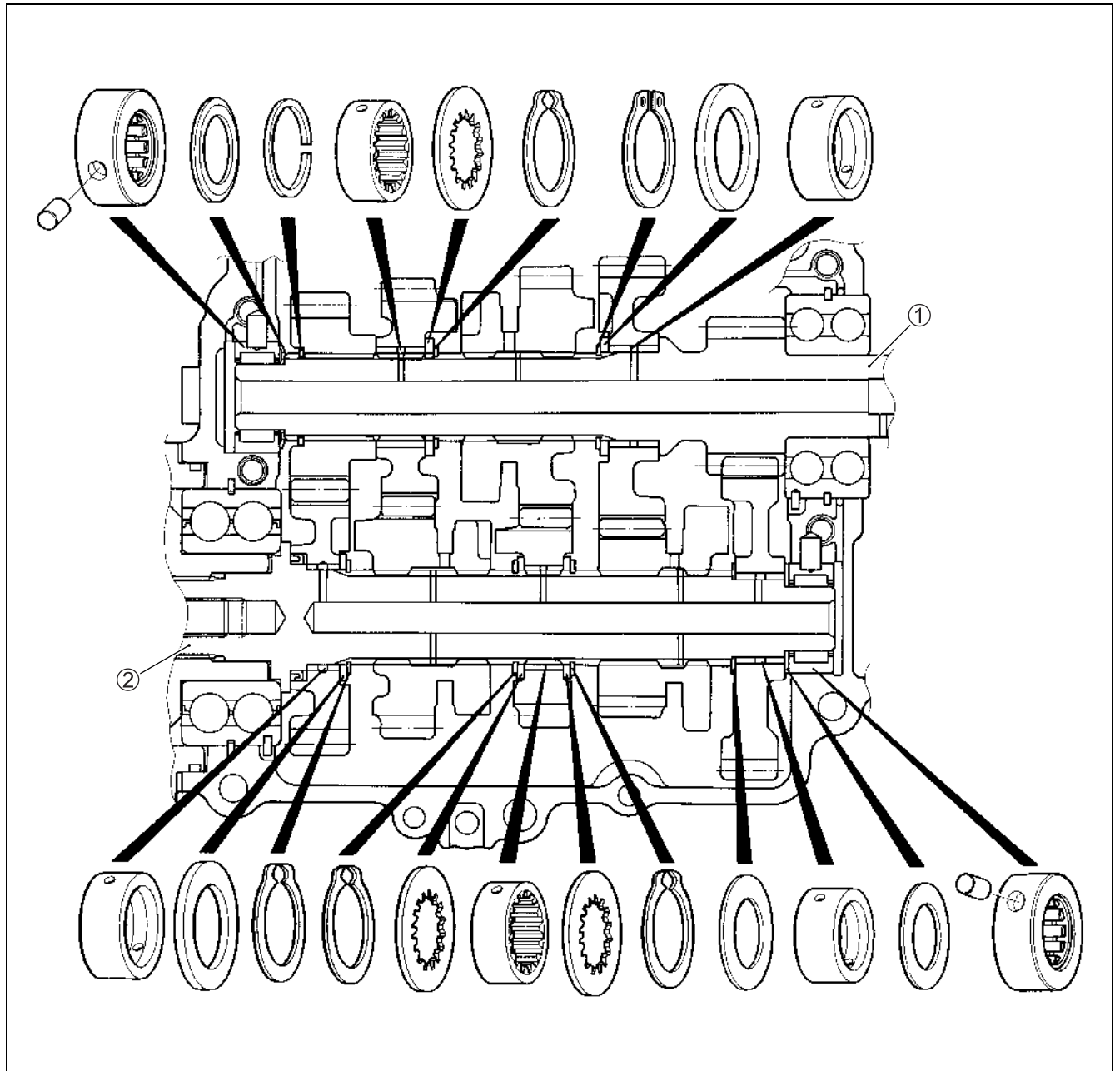

① Countershaft

② Driveshaft

## CRANKCASE

### GEARSHIFT FORK AND GEARSHIFT CAM

#### Removal

- Remove the gearshift cam bearing retainer screws ① and gearshift fork shaft retainer plug ② from the lower crankcase.

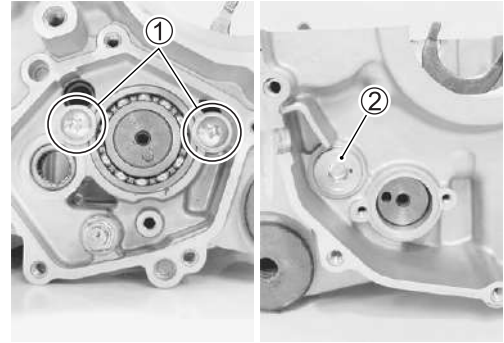

- Remove the gearshift fork shafts ③ and gearshift forks ④ from the lower crankcase.

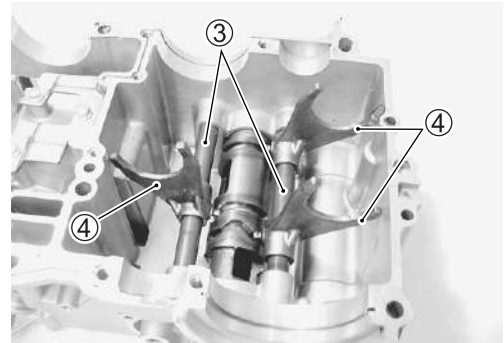

- Remove the gearshift cam ⑤ and its bearing ⑥.

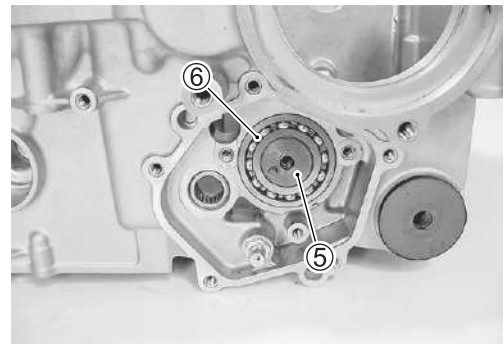

### GEARSHIFT FORK-TO-GROOVE CLEARANCE

- Using a thickness gauge, check the gearshift fork clearance in the groove of its gear.
- The clearance for each gearshift fork plays an important role in the smoothness and positiveness of the shifting action.

**DATA** Shift fork-to-groove clearance:  
Service Limit: 0.50 mm (0.020 in)

**TOOL** 09900-20803: Thickness gauge

- If the clearance checked is noted to exceed the limit specified, replace the fork or its gear, or both.

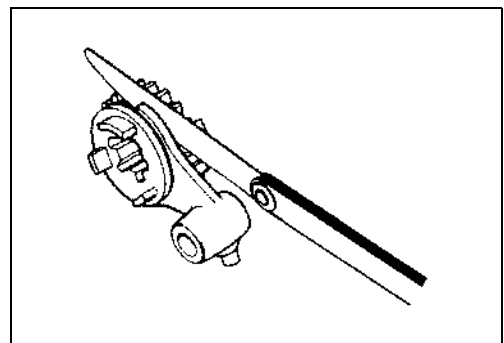

**GEARSHIFT FORK GROOVE WIDTH**

- Measure the gearshift fork groove width using the vernier calipers.

**DATA** Shift fork groove width:  
Standard: 5.0 – 5.1 mm (0.197 – 0.201 in)

**TOOL** 09900-20102: Vernier calipers

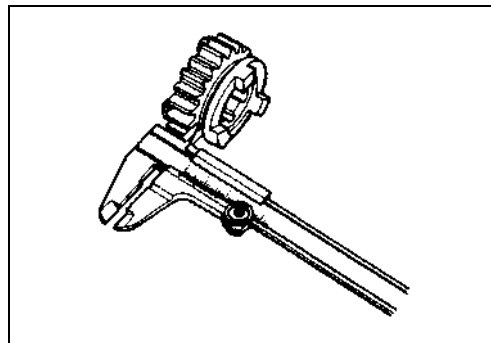
**GEARSHIFT FORK THICKNESS**

- Measure the gearshift fork thickness using the vernier calipers.

**DATA** Shift fork thickness:  
Standard: 4.8 – 4.9 mm (0.189 – 0.193 in)

**TOOL** 09900-20102: Vernier calipers

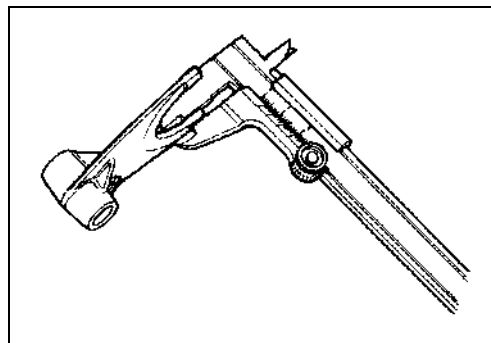
**GEARSHIFT CAM BEARING AND GEARSHIFT SHAFT BEARING****Bearing inspection**

- Inspect the gearshift cam bearing for abnormal noise and smooth rotation.
- Replace the bearings if there is anything unusual.

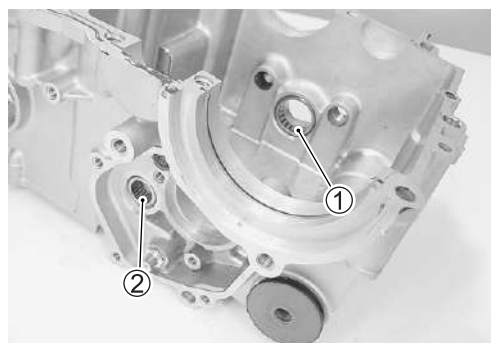

- Inspect the gearshift cam bearing ①, gearshift shaft bearing ② for abnormal noise and smooth rotation while they are in the crankcase.
- Replace a bearing if there is anything unusual.

**Bearing removal**

- Remove the gearshift shaft bearing with the special tools.

**TOOL** 09921-20210: Bearing remover  
09930-30104: Sliding shaft

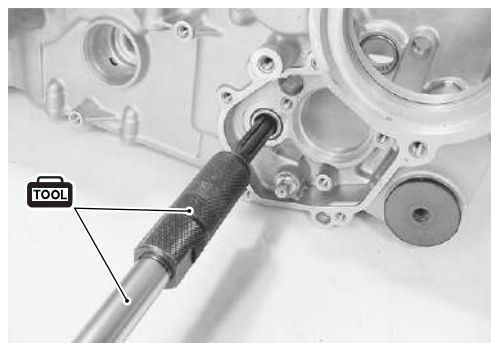

- Remove the gearshift cam bearing with the special tools.

**TOOL** 09923-74511: Bearing remover  
 09930-30104: Sliding shaft

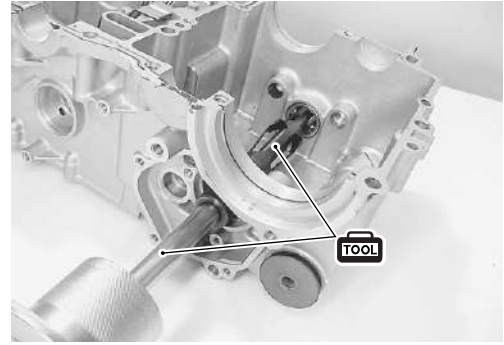

**Installation**

- Install the bearings with the special tool.

**TOOL** 09913-70210: Bearing installer set (①  $\phi 20$ )  
 (②  $\phi 32$ )

**NOTE:**

The stamped mark side of the gearshift shaft bearing ① and gearshift cam bearing ② faces outside.

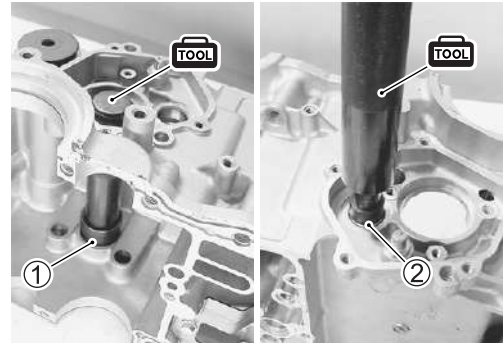

- Install the gearshift cam ③ with the bearing ④.

**NOTE:**

The stamped mark side of the gearshift cam bearing faces outside.

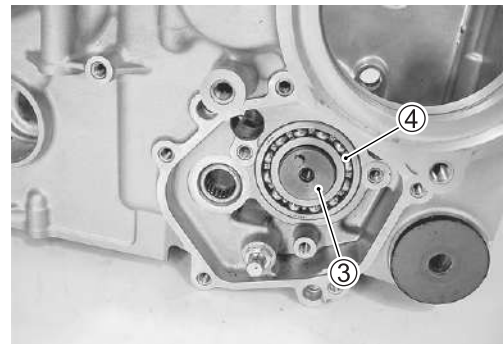

- Install the gearshift forks and their shafts as shown.

- ⑤ For 4th drive gear
- ⑥ For 3rd driven gear
- ⑦ For 5th driven gear

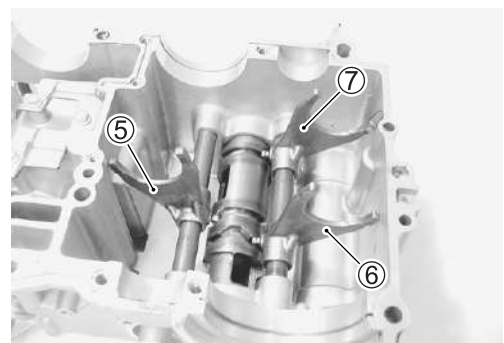
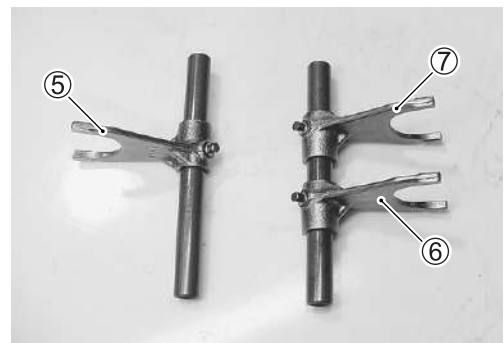

- Apply a small quantity of THREAD LOCK to the bearing retainer screws ⑧ and gearshift arm stopper bolt ⑨.
- Tighten the bearing retainer screws ⑧, gearshift arm stopper bolt ⑨ and gearshift fork shaft retainer plug ⑩ to the specified torque.

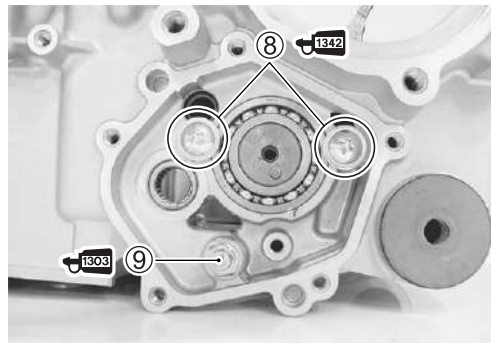

 99000-32050: THREAD LOCK "1342" or equivalent

 99000-32030: THREAD LOCK SUPER "1303"  
or equivalent

 Gearshift arm stopper bolt: 19 N·m (1.9 kgf-m, 13.5 lb-ft)  
Gearshift fork shaft retainer plug:  
35 N·m (3.5 kgf-m, 25.5 lb-ft)

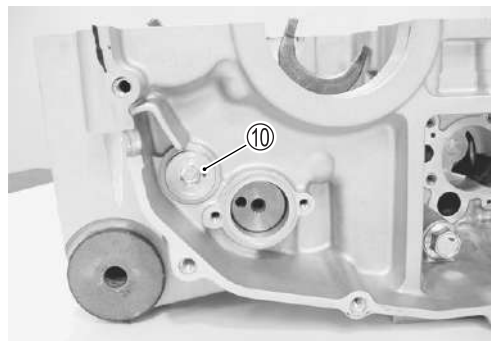

## OIL JET Removal

- Remove the piston cooling oil jets ① and oil jets ② from the upper crankcase.

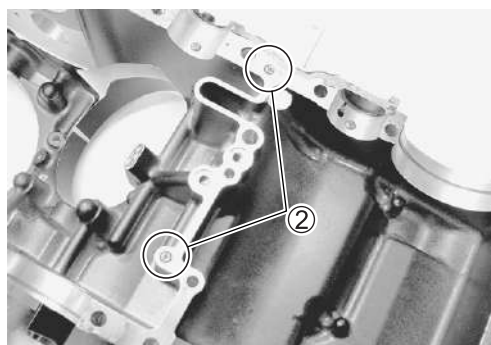
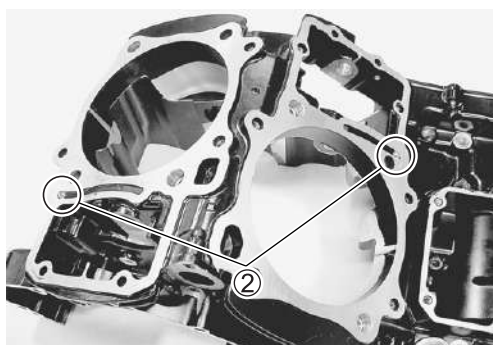
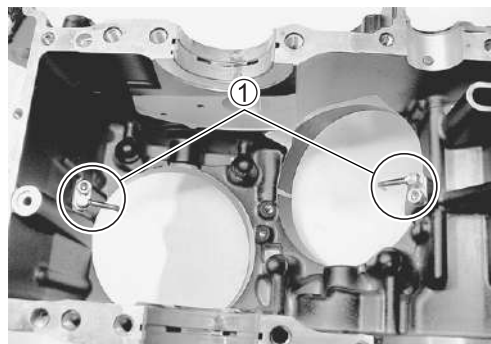

- Remove the oil jets ③ (for front and rear cylinder head side).

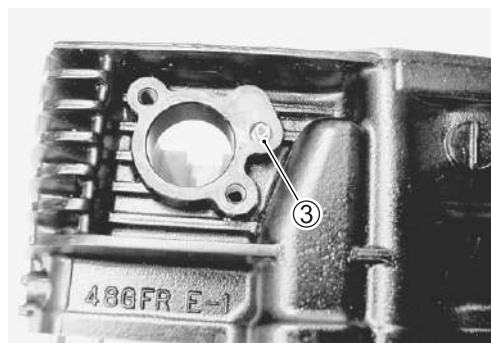



### Inspection and cleaning

- Check the oil jets for clogging.
- Inspect the operation of the oil jet by pushing on the piston with a proper bar
- If they are clogged or piston does not operate, clean their oil passage with a proper wire and compressed air or replace the oil jet with a new one.



### Installation

- Fit the new O-ring ① to each piston cooling oil jet and apply engine oil to them.

#### CAUTION

Use the new O-rings to prevent oil pressure leak.

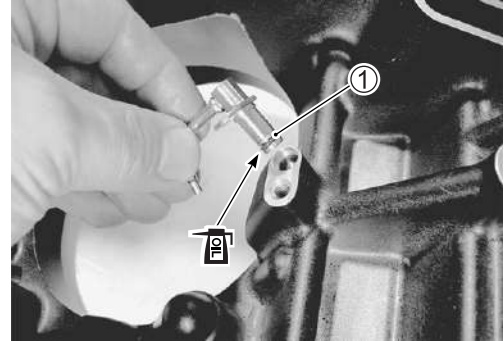

- Install each piston cooling oil jet with the bolt.

#### NOTE:

Apply a small quantity of *THREAD LOCK* to the bolts and tighten them.

 99000-32050: *THREAD LOCK* "1342" or equivalent



- Apply engine oil to the new O-ring ② and ③.

#### CAUTION

Use the new O-rings to prevent oil pressure leak.

- Install the oil jet.

② (for upper crankcase side)

③ (for cylinder head side)

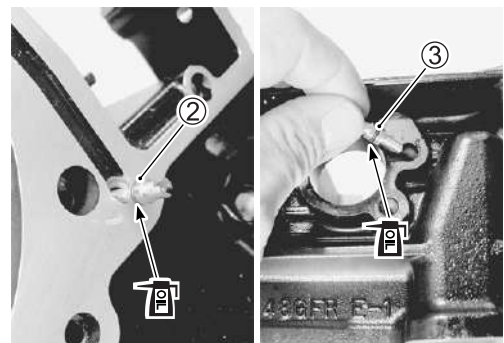

### PLUG

#### Removal

- Remove the water jacket plugs ① (for front and rear cylinder head side).

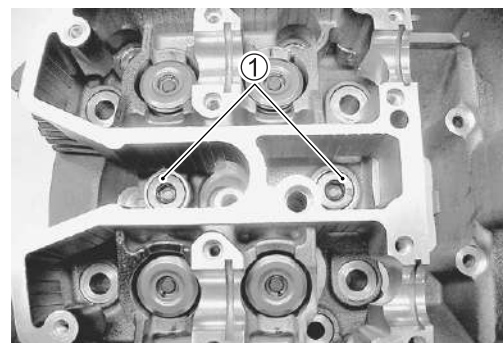



- Remove the oil gallery plugs ② (for upper crankcase side).

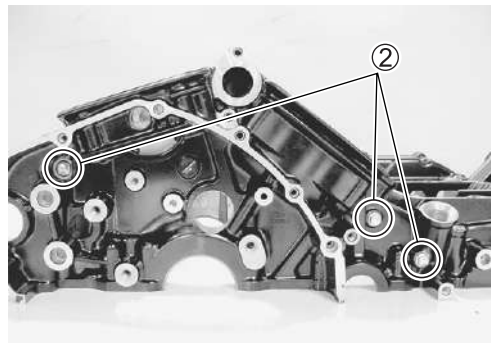

- Remove the oil gallery plugs ③ (for lower crankcase side).

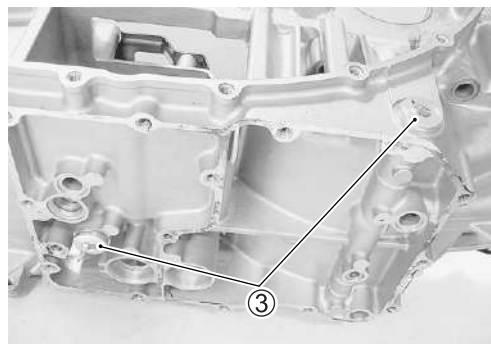
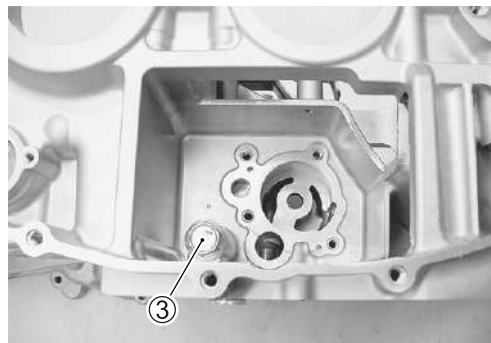

- Remove the oil gallery plugs ④ (for oil pan).

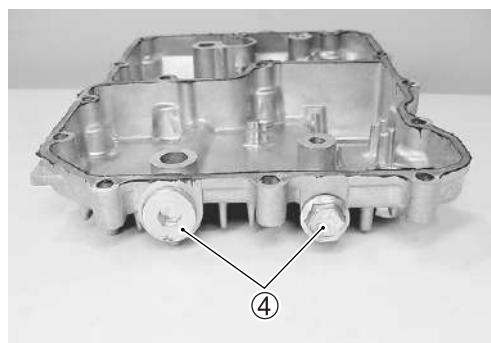

**Installation**

- Apply **THREAD LOCK** to the water jacket plug (1) and oil gallery plugs (2, 3).

**1342 99000-32050: THREAD LOCK "1342" or equivalent**

**NOTE:**

*It is not require to apply **THREAD LOCK** when installing the other removed oil gallery plugs.*

- Tighten each plug to the specified torque.

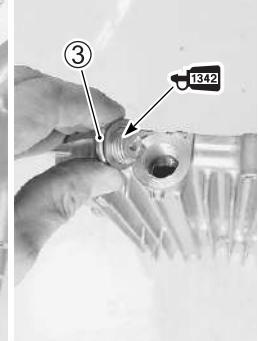
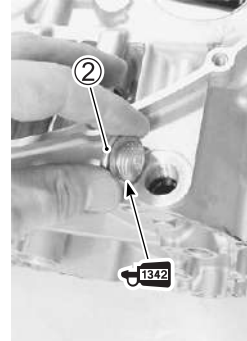
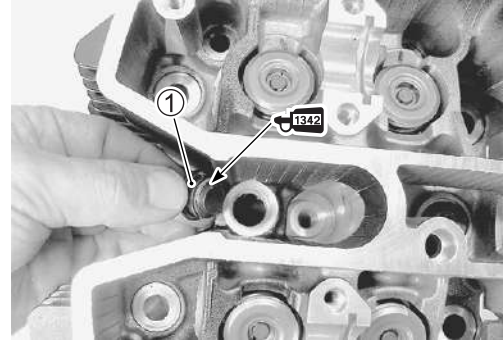

**Water jacket plug (cylinder head) ①:**

**26 N·m (2.6 kgf-m, 19.0 lb-ft)**

**Oil gallery plug (lower crankcase)**

**②: 35 N·m (3.5 kgf-m, 25.5 lb-ft)**

**⑥: 25 N·m (2.5 kgf-m, 18.0 lb-ft)**

**⑦: 21 N·m (2.1 kgf-m, 15.0 lb-ft)**

**Oil gallery plug (oil pan)**

**③: 35 N·m (3.5 kgf-m, 25.5 lb-ft)**

**⑤: 16 N·m (1.6 kgf-m, 11.5 lb-ft)**

**Oil gallery plug (upper crankcase) ④:**

**10 N·m (1.0 kgf-m, 7.0 lb-ft)**

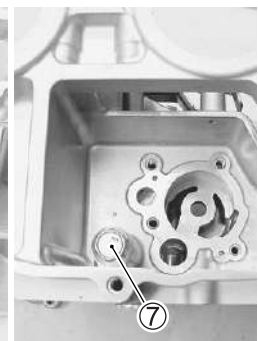
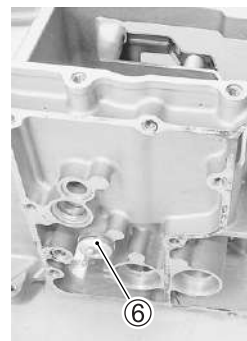
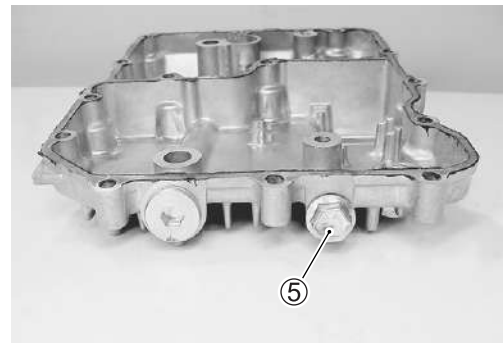
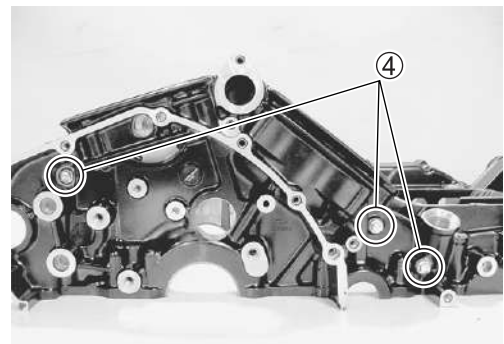

**CAUTION**

**Use each new gasket.**

## BALANCER DRIVEN GEAR

### BALANCER DRIVEN GEAR INSPECTION

Visually inspect the gear teeth for wear and damage. If they are worn, replace the gear with a new one.

### BALANCER DRIVEN GEAR DISASSEMBLY

- Remove the balancer shaft with the special tool.

 **09913-70210: Bearing installer set**

- Hold the balancer drivengear with the special tool.

 **09920-53740: Clutch sleeve hub holder**

- Remove the balancer driven gear No. 1 bolts ① and No. 2 bolts ②.

- Remove the spacers ③ and spring washers ④.

- Remove the balancer driven gear No. 1 ⑤ and No. 2 ⑥ from the special tool.
- Remove the springs ⑦.

### BALANCER DRIVEN GEAR REASSEMBLY

- Set the springs ① diagonally to the grooves.
- Set the balancer driven gear No. 2 ② to the No. 1.

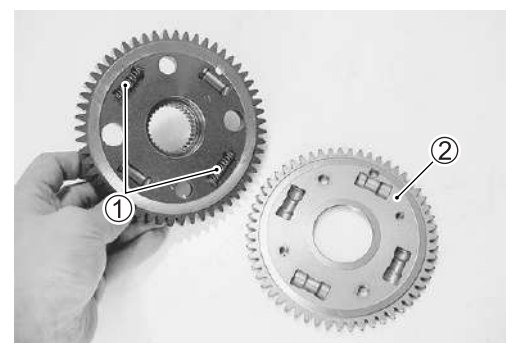
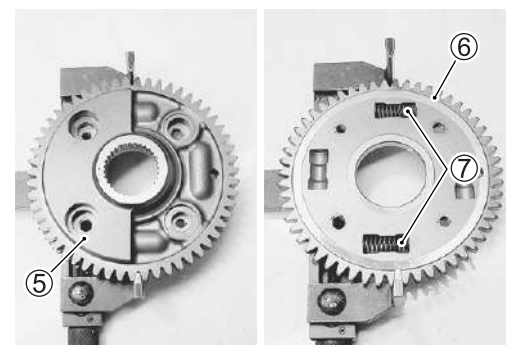
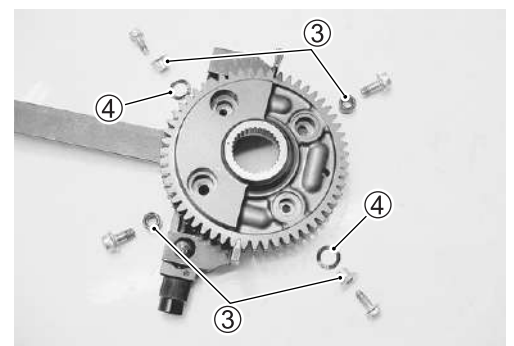
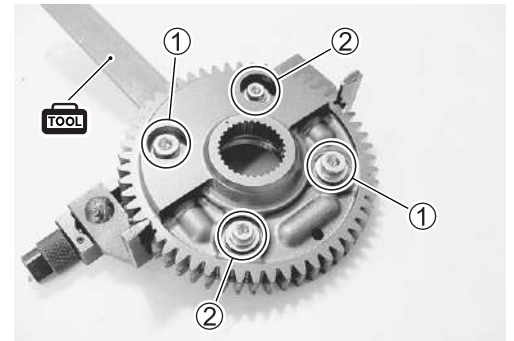
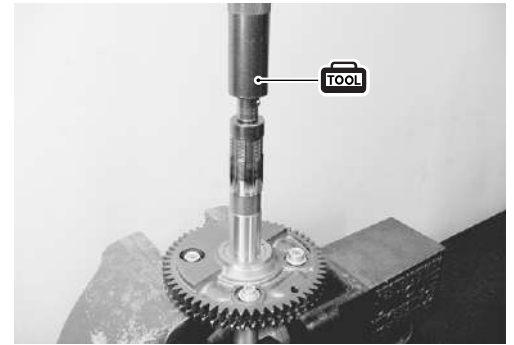

- Hold the balancer driven gear No. 2 ③ with the special tool.

 **09920-53740: Clutch sleeve hub holder**

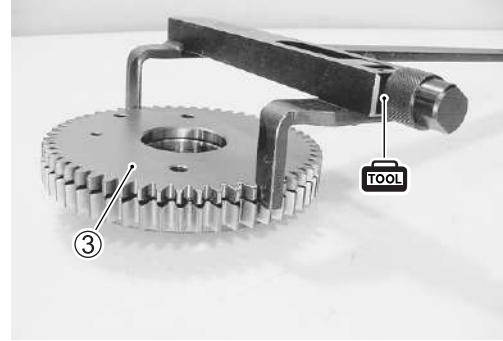

- Turn the balancer driven gear No. 1 ④ and align the holes.

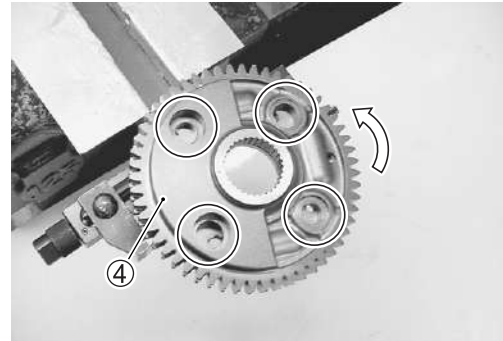

- Apply THREAD LOCK SUPER to the bolts (⑤, ⑥).

 **99000-32030: THREAD LOCK SUPER "1303"**  
or equivalent

- Tighten the bolts (⑤, ⑥) to the specified torque.

 **Balancer driven gear No. 1 bolt ⑤:**  
10 N·m (1.0 kgf-m, 7.0 lb-ft)  
**Balancer driven gear No. 2 bolt ⑥:**  
25 N·m (2.5 kgf-m, 18.0 lb-ft)

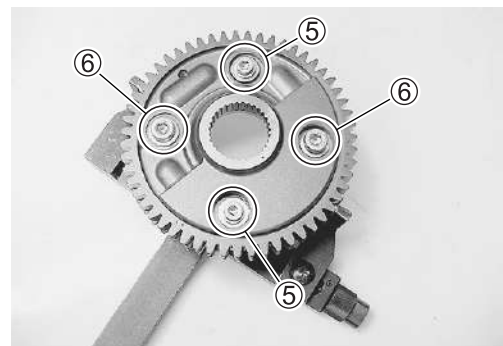

- Set the balancer shaft so that its slit ① is aligned with the punch mark ② on the balancer driven gear.

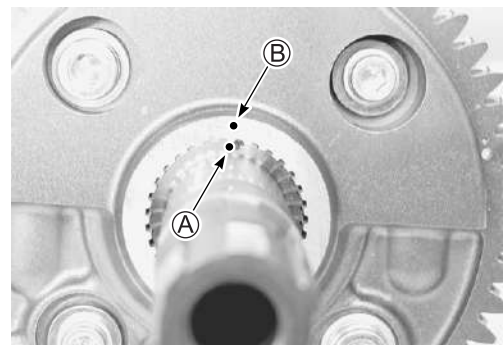

- Install the balancer driven gear assembly onto the balancer shaft with the special tool.

 **09913-70210: Bearing installer set (25 mm)**



## CRANKSHAFT AND CONROD

### CONROD SMALL END I.D.

- Using a small bore gauge, measure the inside diameter of the conrod small end.

**DATA** Conrod small end I.D.:

Service Limit: 23.040 mm (0.9071 in)

**TOOL** 09900-20602: Dial gauge (1/1 000 mm, 1 mm)

09900-22403: Small bore gauge (18 – 35 mm)

- If the inside diameter of the conrod small end exceeds the limit, replace the conrod.

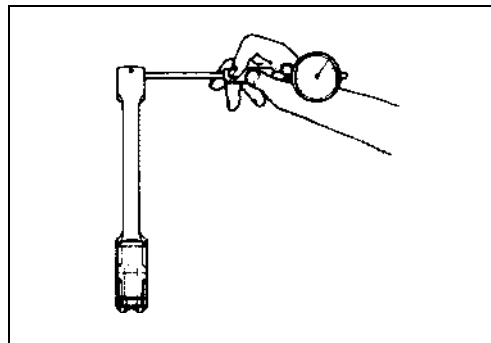

### CONROD BIG END SIDE CLEARANCE

- Inspect the conrod side clearance by using a thickness gauge.
- If the clearance exceeds the limit, remove the conrod and inspect the conrod big end width and the crank pin width.
- If the width exceeded the limit, replace conrod or crankshaft.

**DATA** Conrod big end side clearance:

Service Limit: 0.30 mm (0.012 in)

**TOOL** 09900-20803: Thickness gauge

**DATA** Conrod big end width:

Standard: 23.95 – 24.00 mm (0.943 – 0.945 in)

**TOOL** 09900-20205: Micrometer (0 – 25 mm)

**DATA** Crank pin width:

Standard: 24.10 – 24.15 mm (0.949 – 0.951 in)

**TOOL** 09900-20605: Dial calipers (1/100 mm, 10 – 34 mm)

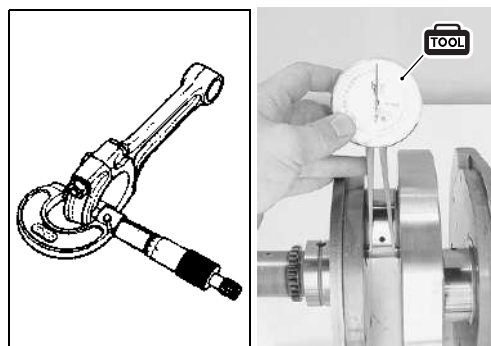

### CONROD-CRANK PIN BEARING INSPECTION

- Loosen the bearing cap bolts, and tap the bearing cap bolt lightly with plastic mallet to remove the bearing cap.





- Remove the conrods, and mark them to identify the cylinder position.
- Inspect the bearing surfaces for any sign of fusion, pitting, burn, or flaws. If any, replace them with a specified set of bearings.



### CONROD-BIG END BEARING SELECTION

- Place the plastigauge axially along the crank pin, avoiding the oil hole, as shown.

#### 09900-22301: Plastigauge

- Tighten the conrod cap bolts to the specified torque, in two stages. (→ 3-73)

#### CAUTION

- \* Apply engine oil to the bearing cap bolt.
- \* Never rotate the crankshaft or conrod when a piece of plastigauge is installed.

- The number faces the intake side ①.

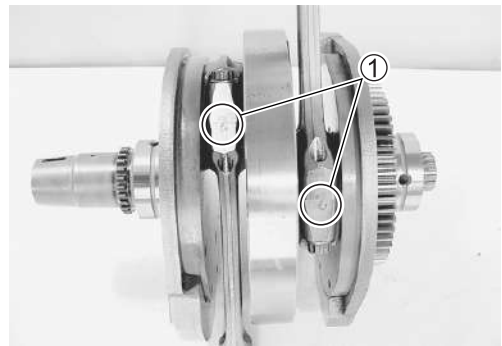

- Remove the bearing caps and measure the width of the compressed plastigauge using the envelope scale. This measurement should be taken at the widest part of the compressed plastigauge.

#### Conrod big end oil clearance:

**Standard: 0.032 – 0.056 mm (0.0013 – 0.0022 in)**

**Service Limit: 0.080 mm (0.0031 in)**

- If the oil clearance exceeds the service limit, select the specified bearings from the bearing selection table.

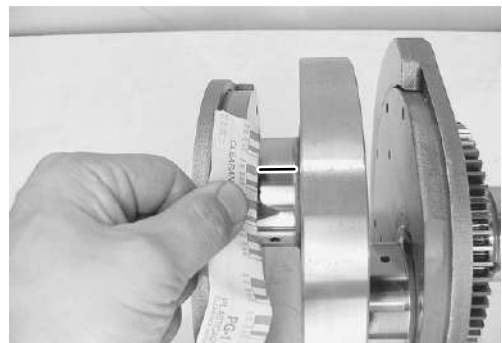



- Check the corresponding conrod I.D. code number (“1” or “2”) <sup>Ⓐ</sup>.

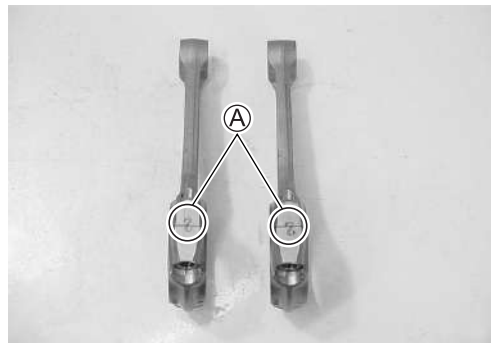

- Check the corresponding crank pin O.D. code number (“1”, “2” or “3”) <sup>Ⓑ</sup>.

**DATA** Bearing selection table

Conrod I.D. <sup>Ⓐ</sup>	Code	Crank pin O.D. <sup>Ⓑ</sup>		
		1	2	3
	1	Green	Black	Brown
	2	Black	Brown	Yellow

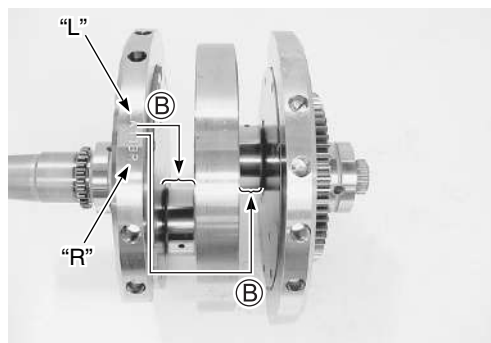

**DATA** Conrod I.D.

Code	I.D. specification
1	58.000 – 58.008 mm (2.2835 – 2.2838 in)
2	58.008 – 58.016 mm (2.2838 – 2.2841 in)

**DATA** Crank pin O.D.

Code	O.D. specification
1	54.992 – 55.000 mm (2.1650 – 2.1654 in)
2	54.984 – 54.992 mm (2.1647 – 2.1650 in)
3	54.976 – 54.984 mm (2.1644 – 2.1647 in)

**TOOL** 09900-20202: Micrometer (25 – 50 mm)**DATA** Bearing thickness

Color (Part No.)	Thickness
Green (12164-48G00-0A0)	1.480 – 1.484 mm (0.0583 – 0.0584 in)
Black (12164-48G00-0B0)	1.484 – 1.488 mm (0.0584 – 0.0586 in)
Brown (12164-48G00-0C0)	1.488 – 1.492 mm (0.0586 – 0.0587 in)
Yellow (12164-48G00-0D0)	1.492 – 1.496 mm (0.0587 – 0.0589 in)

**CAUTION**

The bearings must be replaced as a set.

**INSTALLATION**

- When fitting the bearings to the bearing cap and conrod, be sure to fix the stopper part (A) first, and press in the other end.
- Apply a MOLYBDENUM OIL SOLUTION to the crank pin and bearing surface.

**NOTE** MOLYBDENUM OIL SOLUTION**CAUTION**

Be sure to clean the conrod big end.

- When fitting the conrod cap, make sure that I.D. code (B) on each conrod faces intake side.

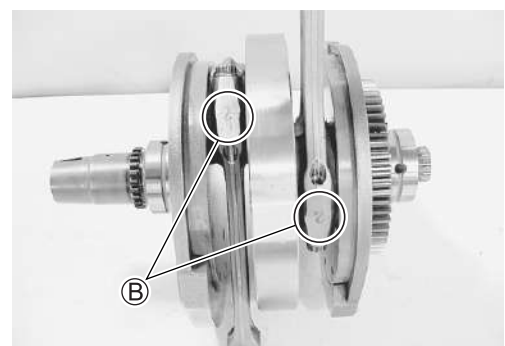
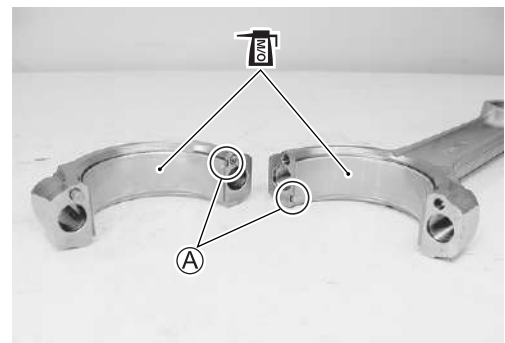
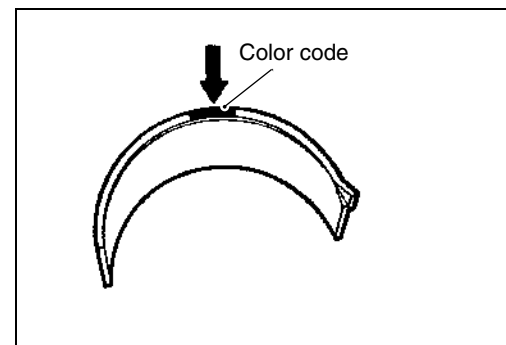

- Apply engine oil to the bearing cap bolts.
- Tighten the bearing cap bolts as following two steps.

#### Conrod bearing cap bolt

**(Initial) : 35 N·m (3.5 kgf-m, 25.5 lb-ft)**

**(Final) : After tightening the bolts to the above torque, tighten them 1/4 of a turn (90°).**

- Check the conrod movement for smooth turning.

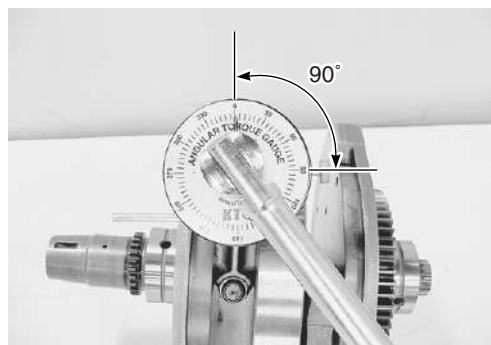
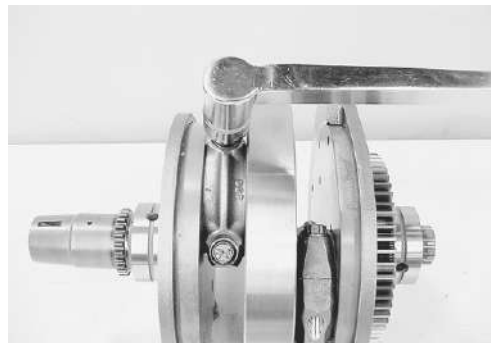

## CRANKSHAFT JOURNAL BEARING INSPECTION

- Inspect each bearing of upper and lower crankcases for any damage.

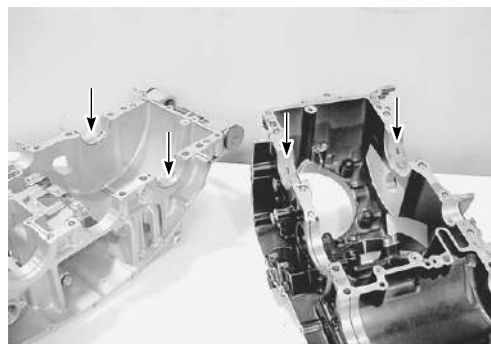

## SELECTION

- Place the plastigauge axially along the crankshaft journal, avoiding the oil hole, as shown.

 **09900-22301: Plastigauge**

### CAUTION

**Never rotate the crankshaft when a piece of plastigauge is installed.**

- Tighten the crankcases bolts to the specified torque, in two stages. (☞ 3-82)

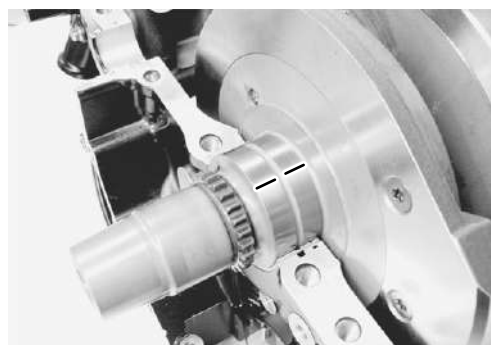

- Remove the lower crankcase and measure the width of the compressed plastigauge using the envelope scale. This measurement should be taken at the widest part of the compressed plastigauge.

**DATA** Crankshaft journal oil clearance:

**Standard: 0.016 – 0.034 mm (0.0006 – 0.0013 in)**

**Service Limit: 0.080 mm (0.0031 in)**

- If the oil clearance exceeds the service limit, select the specified bearings from the bearing selection table.
- Check the corresponding crankcase journal I.D. code number (A), “A”, “B” or “C” which is stamped on the rear of upper crankcase.
- Check the corresponding crankshaft journal O.D. code number (B), “A”, “B” or “C” which is stamped on the crankshaft.

**DATA** Bearing selection table

		Crankshaft journal O.D. (B)		
		A	B	C
Crankcase I.D. (A)	A	Green	Black	Brown
	B	Black	Brown	Yellow
	C	Brown	Yellow	Blue

**DATA** Crankcase I.D. specification

Code	I.D. specification
A	59.000 – 59.006 mm (2.3228 – 2.3231 in)
B	59.006 – 59.012 mm (2.3231 – 2.3233 in)
C	59.012 – 59.018 mm (2.3233 – 2.3235 in)

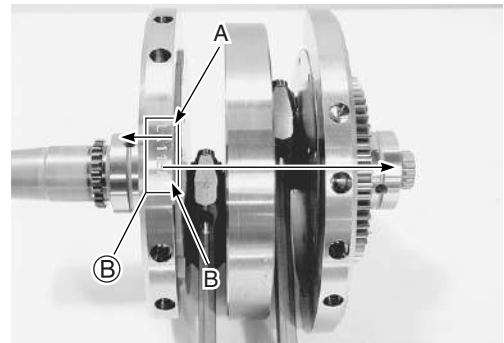
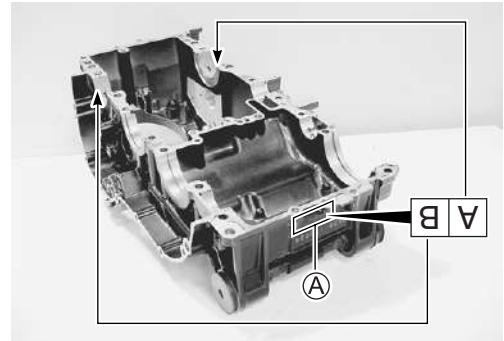
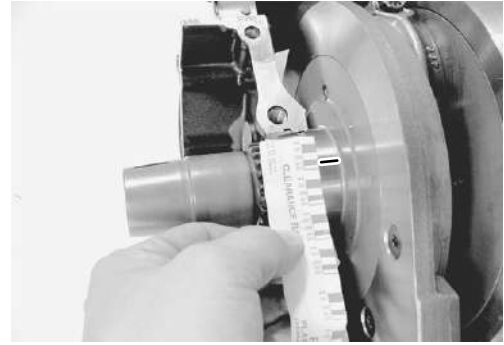

**DATA** Crankshaft journal O.D. specification

Code	O.D. specification
A	54.994 – 55.000 mm (2.1651 – 2.1654 in)
B	54.988 – 54.994 mm (2.1649 – 2.1651 in)
C	54.982 – 54.988 mm (2.1646 – 2.1649 in)

**TOOL** 09900-20203: Micrometer (50 – 75 mm)**DATA** Bearing thickness specification

Color (Part No.)	Thickness
Green (12229-48G00-0A0)	1.989 – 1.992 mm (0.0783 – 0.0784 in)
Black (12229-48G00-0B0)	1.992 – 1.995 mm (0.0784 – 0.0785 in)
Brown (12229-48G00-0C0)	1.995 – 1.998 mm (0.0785 – 0.0787 in)
Yellow (12229-48G00-0D0)	1.998 – 2.001 mm (0.0787 – 0.0788 in)
Blue (12229-48G00-0E0)	2.001 – 2.004 mm (0.0788 – 0.0789 in)

**NOTE:**

Upper and lower crankshaft journal bearings are the same.

**INSTALLATION**

- When fitting the crankshaft journal bearings to the upper and lower crankcases, be sure to fix the stopper part (A) first and press the other end.

**CAUTION**

**Do not touch the bearing surfaces with your hands.  
Grasp by the edge of the bearing shell.**

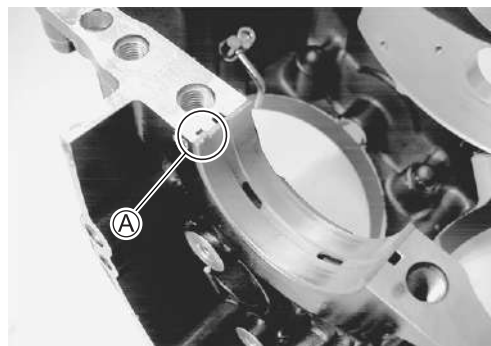

## CRANKSHAFT THRUST BEARING

- With the crankshaft and thrust bearing ① inserted in the upper crankcase, measure the thrust clearance by using the thickness gauge.

### **DATA** Thrust clearance:

**Standard: 0.100 – 0.200 mm (0.0039 – 0.0078 in)**

### **TOOL** 09900-20803: Thickness gauge

- If the thrust clearance exceeds the standard range, adjust the thrust clearance by the following procedures.

## CRANKSHAFT THRUST CLEARANCE ADJUSTMENT

- Remove the thrust bearing and measure its thickness with a micrometer.
- If the thickness of the thrust bearing is below standard, replace it with a new one and once again perform the thrust clearance measurement listed above, checking to make sure it is within standard.
- Select a thrust bearing from the selection table. (☞ 3-77)

### **DATA** Thrust bearing thickness:

**Standard: 2.250 – 2.550 mm (0.0886 – 0.1004 in)**

### **TOOL** 09900-20205: Micrometer (0 – 25 mm)

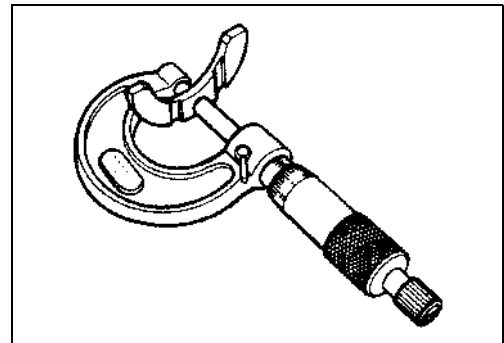
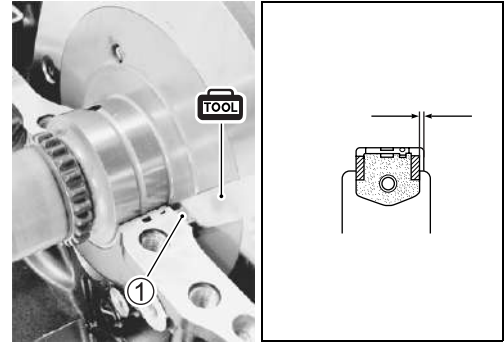



**DATA** Thrust bearing selection table

Clearance before inserting left-side thrust bearing	Color (Part No.)	Thrust bearing thickness	Thrust clearance
2.400 – 2.450 mm (0.0944 – 0.0965 in)	Red (12228-48G00-0A0)	2.250 – 2.300 mm (0.0886 – 0.0906 in)	0.100 – 0.200 mm (0.0039 – 0.0079 in)
2.450 – 2.500 mm (0.0965 – 0.0984 in)	Black (12228-48G00-0B0)	2.300 – 2.350 mm (0.0906 – 0.0925 in)	0.100 – 0.200 mm (0.0039 – 0.0079 in)
2.500 – 2.550 mm (0.0984 – 0.1004 in)	Blue (12228-48G00-0C0)	2.350 – 2.400 mm (0.0925 – 0.0945 in)	0.100 – 0.200 mm (0.0039 – 0.0079 in)
2.550 – 2.600 mm (0.1004 – 0.1024 in)	Green (12228-48G00-0D0)	2.400 – 2.450 mm (0.0945 – 0.0965 in)	0.100 – 0.200 mm (0.0039 – 0.0079 in)
2.600 – 2.650 mm (0.1024 – 0.1043 in)	Yellow (12228-48G00-0E0)	2.450 – 2.500 mm (0.0965 – 0.0984 in)	0.100 – 0.200 mm (0.0039 – 0.0079 in)
2.650 – 2.700 mm (0.1043 – 0.1063 in)	White (12228-48G00-0F0)	2.500 – 2.550 mm (0.0984 – 0.1004 in)	0.100 – 0.200 mm (0.0039 – 0.0079 in)

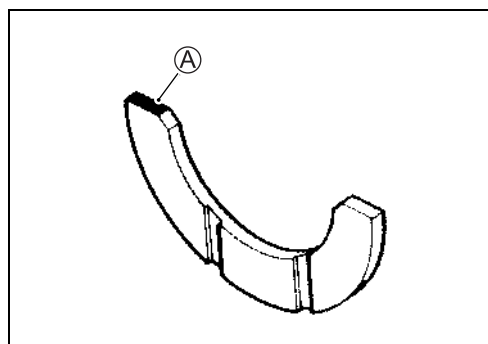

Ⓐ Color code

## ENGINE REASSEMBLY

- Reassemble the engine in the reverse order of disassembly.
- The following steps require special attention or precautionary measures should be taken.

### NOTE:

Apply engine oil to each running and sliding part before reassembling.

### CRANKSHAFT

- Install the crankshaft assembly to the upper crankcase.
- Apply a MOLYBDENUM OIL SOLUTION to each crankshaft journal and bearing lightly.

#### MOLYBDENUM OIL SOLUTION

- Insert the thrust bearing with oil groove **(A)** facing the crank web.

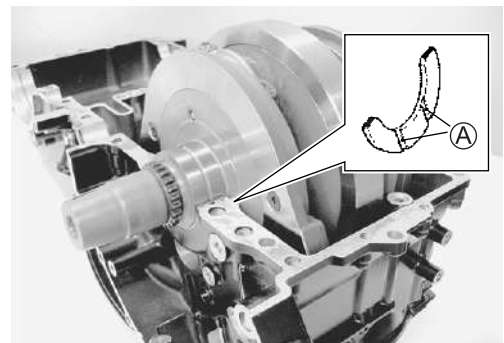
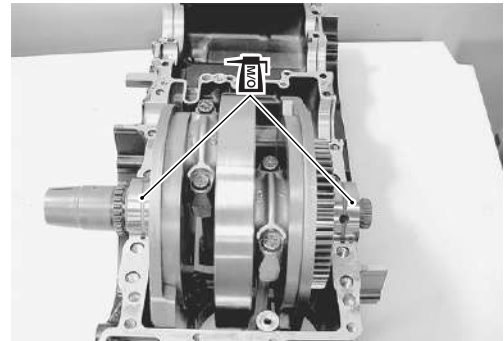

### BALANCER SHAFT

- Install the balancer shaft on the upper crankcase.

### NOTE:

Align the C-ring with the groove of bearing and the bearing pin with the indent on the bearing.

- Set the balancer shaft so that its punch mark **(A)** is aligned with the punch mark **(B)** on the crankshaft.

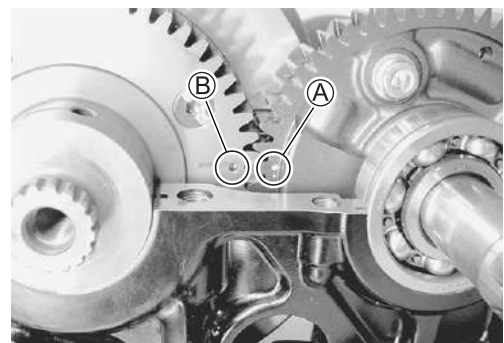
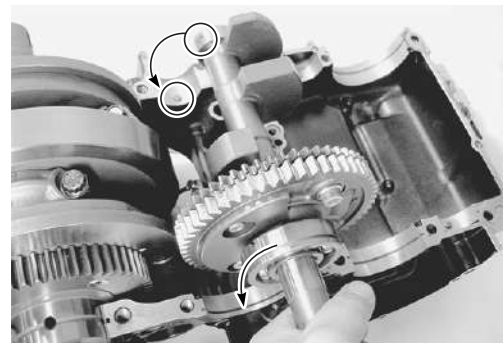

- Turn the bearing to install the bearing dowel pin ③ in the position.
- Install the oil seal ①.

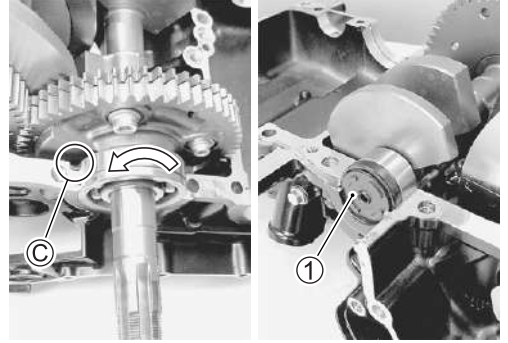

## TRANSMISSION

- Install the countershaft assembly on the upper crankcase.

### NOTE:

*Align the C-ring with the groove of bearing and the bearing pin with the indent on the bearing.*

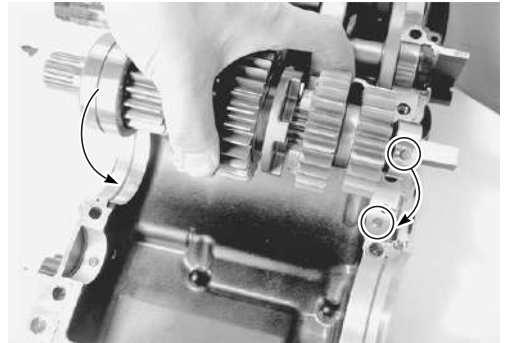

- Install the driveshaft assembly on the upper crankcase.

### NOTE:

*Align the C-ring with the groove of bearing and the bearing pin with the indent on the bearing.*

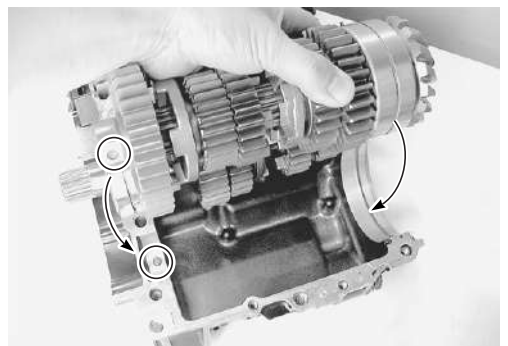

- Turn the bearings to install the bearing dowel pins ④ in the respective positions.

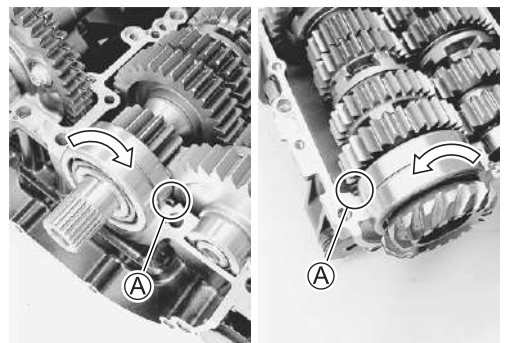

- Install the O-rings ①.
- Apply SUZUKI SUPER GREASE “A” to the O-rings.

 99000-25010: SUZUKI SUPER GREASE “A”  
or equivalent

**CAUTION**

**Use a new O-ring to prevent oil leakage.**

- Install the dowel pins ②.

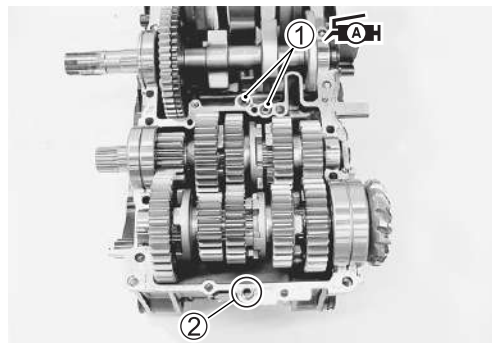
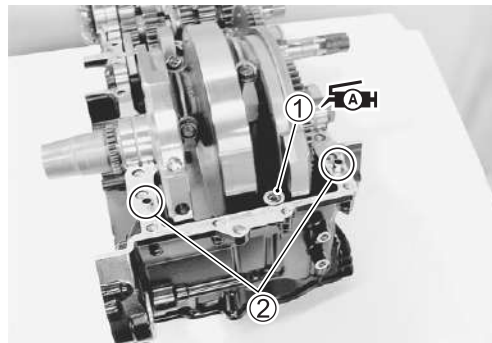

- Apply SUZUKI BOND to the mating surface of the lower crankcase.

**1215** 99000-31110: SUZUKI BOND “1215” or equivalent

**NOTE:**

*Use of SUZUKI BOND is as follows:*

- \* *Make surfaces free from moisture, oil, dust and other foreign materials.*
- \* *Spread on surfaces thinly to form an even layer, and assemble the crankcases within few minutes.*
- \* *Take extreme care not to apply any BOND to the oil hole, oil groove and bearing.*
- \* *Apply to distorted surfaces as it forms a comparatively thick film.*

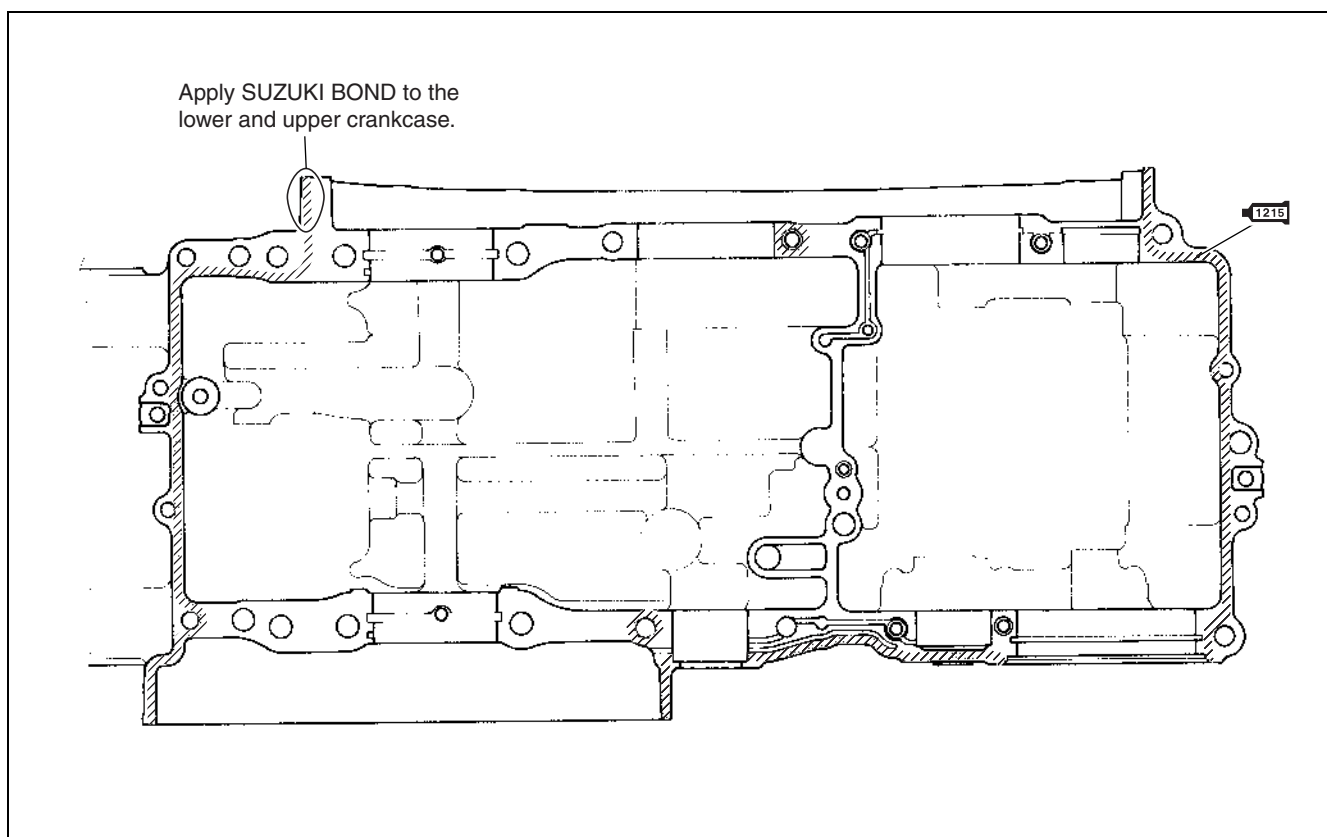

- Match the upper and lower crankcases.

**NOTE:**

*Align the gearshift forks ③ with their grooves ④.*

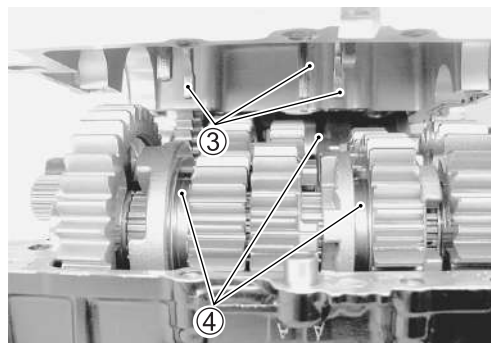

- Tighten the crankcase bolts a little at a time to equalize the pressure.

**NOTE:**

- \* Fit the new copper washers to the crankcase bolts ②.
- \* Fit the new gasket washers to the crankcase bolts ③.

**🔧 Crankcase bolt: (M6): 11 N·m (1.1 kgf-m, 8.0 lb-ft)**  
**(M8): 26 N·m (2.6 kgf-m, 19.0 lb-ft)**  
**(M10) Initial: 30 N·m (3.0 kgf-m, 21.5 lb-ft)**  
**Final: 50 N·m (5.0 kgf-m, 36.0 lb-ft)**

**CAUTION**

**Use the new copper washers and new gasket washers to prevent oil leakage.**

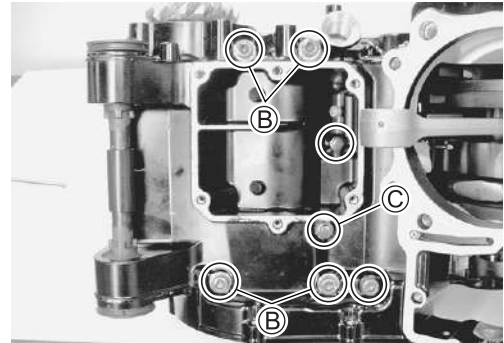
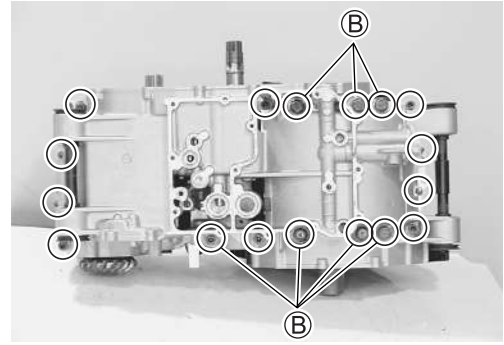



- Apply SUZUKI BOND to the mating surface of the breather cover.

**1207B** 99000-31140: SUZUKI BOND “1207B” or equivalent

**NOTE:**

*Use of SUZUKI BOND is as follows:*

- \* *Make surfaces free from moisture, oil, dust and other foreign materials.*
- \* *Spread on surfaces thinly to form an even layer, and assemble the breather cover within few minutes.*
- \* *Apply to distorted surfaces as it forms a comparatively thick film.*

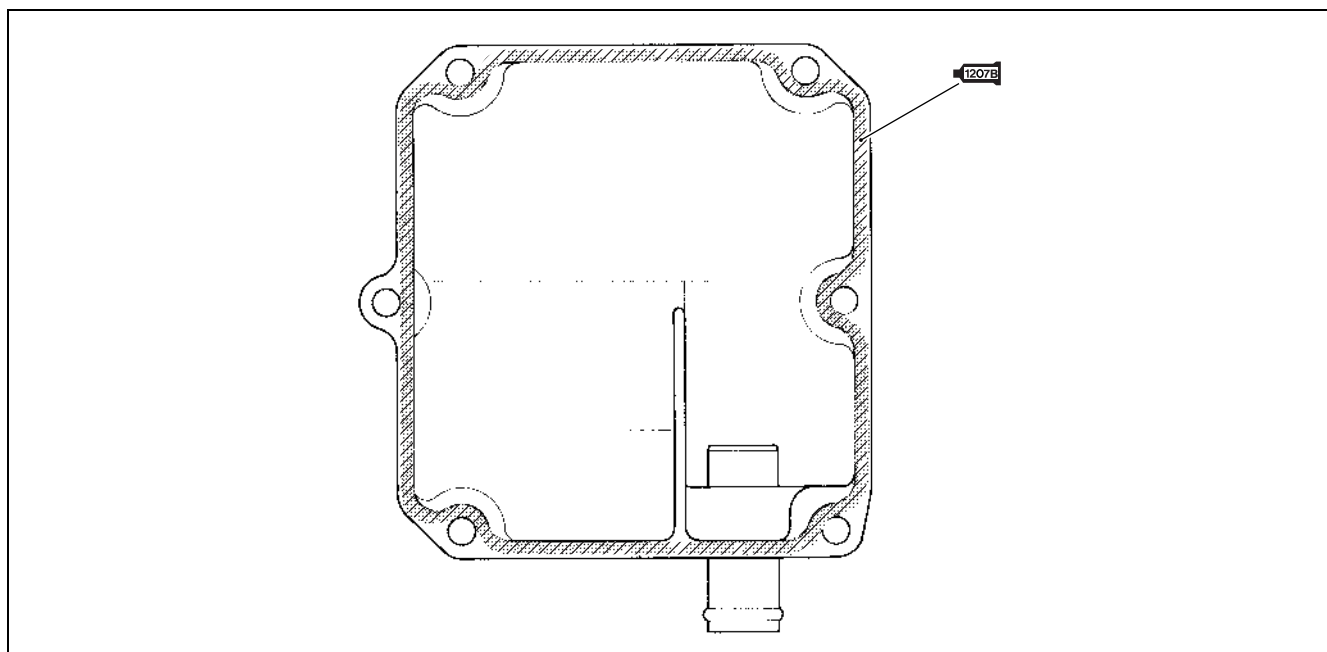

- Tighten the breather cover bolts.

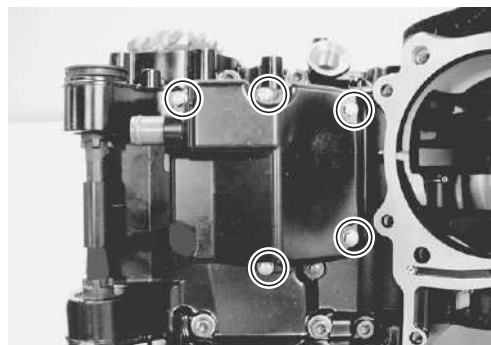

- Check that the driveshaft and countershaft rotate smoothly.

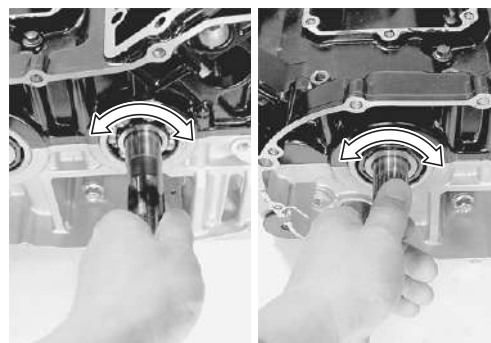

**OIL STRAINER**

- Clean the oil strainer using compressed air.
- Install the oil strainers ①.

**NOTE:**

Align the boss (A) with the groove (B) of crankcase.

- Apply SUZUKI SUPER GREASE "A" to the O-rings.

 99000-25010: SUZUKI SUPER GREASE "A" or equivalent

**CAUTION**

Use a new O-ring to prevent oil leakage.

**NOTE:**

Align the oil strainer (C) with the lower crankcase hole (D).

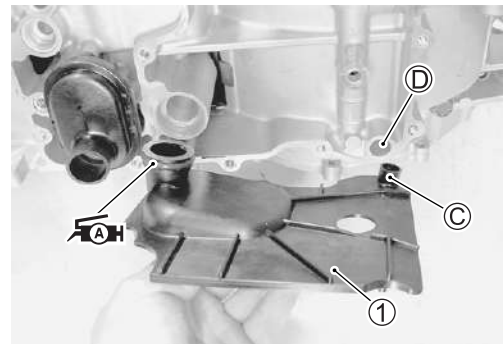
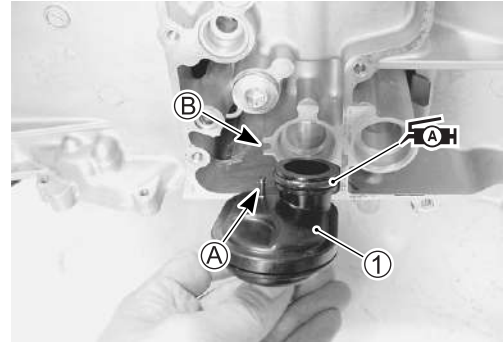

**OIL PRESSURE REGULATOR**

- Apply SUZUKI SUPER GREASE "A" to the O-rings and press in the oil pressure regulator ① to the lower crankcase.

 99000-25010: SUZUKI SUPER GREASE "A" or equivalent

**CAUTION**

Use a new O-ring to prevent oil leakage.

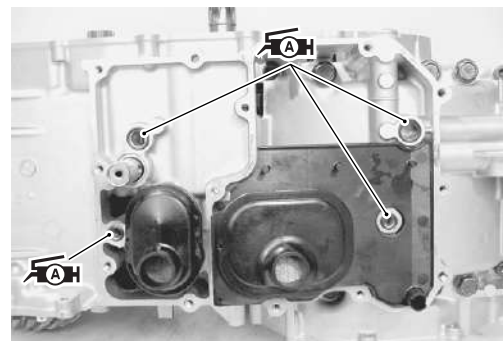
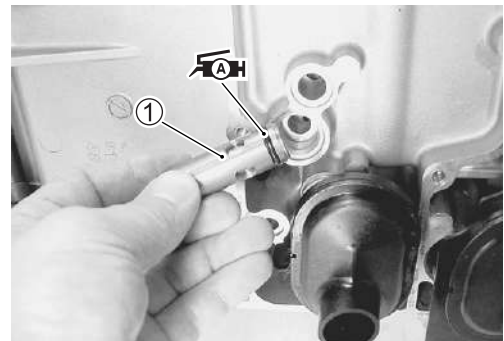

**OIL PAN**

- Apply SUZUKI BOND to the mating surface of the oil pan.

 99000-31110: SUZUKI BOND “1215” or equivalent

**NOTE:**

Use of SUZUKI BOND is as follows:

- \* Make surfaces free from moisture, oil, dust and other foreign materials.
- \* Apply to distorted surfaces as it forms a comparatively thick film.

- Install the oil pan.

**NOTE:**

- \* Fit the new gasket washers to the oil pan bolts (A).
- \* Fit the clamp (B) and stay (C) to the bolts.

**CAUTION**

Use a new gasket washer to prevent oil leakage.

- Tighten the oil pan bolts diagonally.

**WATER PUMP**

- Apply SUZUKI SUPER GREASE “A” to the O-ring.

**CAUTION**

Use a new O-ring to prevent oil leakage.

 99000-25010: SUZUKI SUPER GREASE “A”  
or equivalent

- Install the water pump.

**NOTE:**

When install the water pump, fit the convex part (A) of the oil pump shaft onto the concave part (B) of the water pump shaft.

- Tighten the water pump mounting bolts.

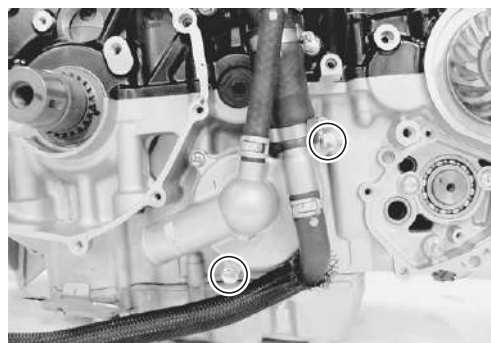
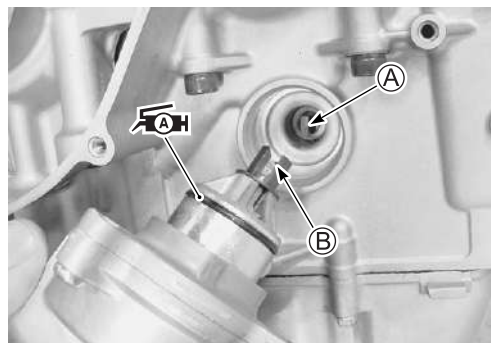
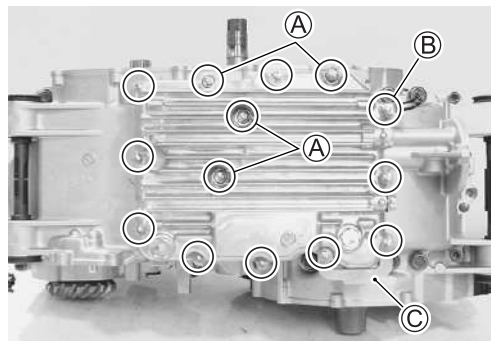
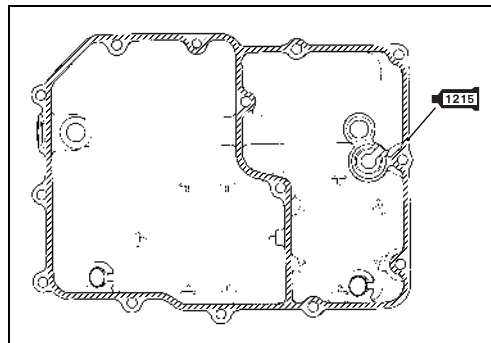

- Apply engine coolant to the O-ring.

**CAUTION**

**Use a new O-ring to prevent engine coolant leakage.**

- Install the water inlet pipe ①.
- Tighten the water inlet pipe mounting bolts.

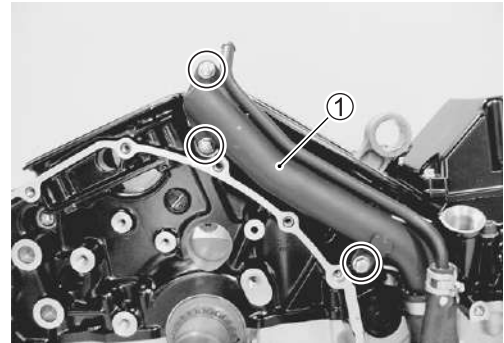
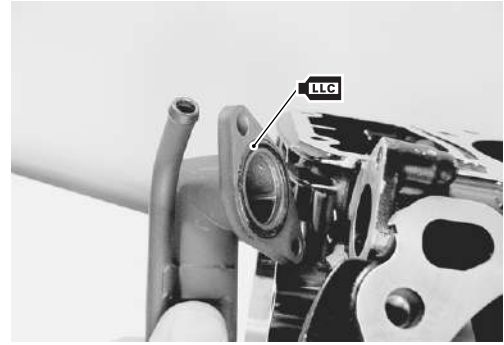
**OIL PRESSURE SWITCH**

- Apply SUZUKI BOND to the thread part of oil pressure switch and tighten oil pressure switch to the specified torque.

**1215** 99000-31110: SUZUKI BOND “1215” or equivalent

**Oil pressure switch: 14 N·m (1.4 kgf·m, 10.0 lb-ft)**

**NOTE:**

*Be careful not to apply SUZUKI BOND to the hole of thread end.*

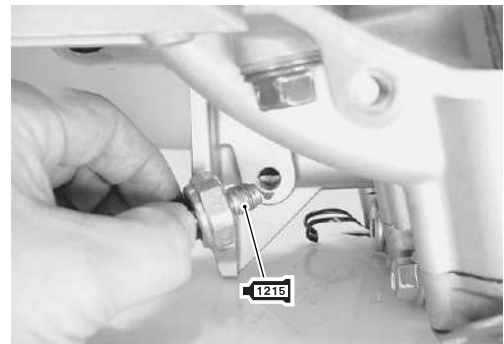
**OIL COOLER**

- Apply engine oil to the O-ring.

**CAUTION**

**Use the new O-ring to prevent oil pressure leak.**

**NOTE:**

*When install the oil cooler, fit the convex part ① of the lower crankcase onto the concave part ② of the oil cooler.*

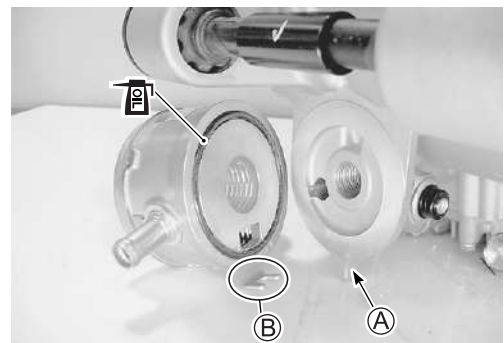

- Install the oil cooler to the crankcase and tighten the bolt to the specified torque.

**Oil cooler union bolt: 70 N·m (7.0 kgf·m, 50.5 lb-ft)**

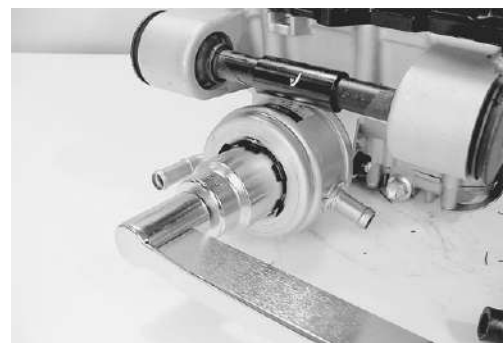

**OIL FILTER**

- Install the oil filter with the special tool. (☞ 2-18)

 **09915-40610: Oil filter wrench**

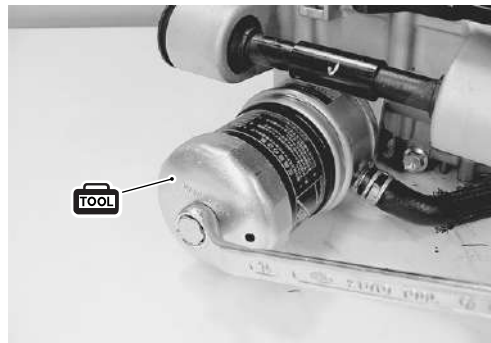
**OIL PUMP DRIVE GEAR AND DRIVEN GEAR**

- Install the washer ① and pin ②.

**NOTE:**

*Be careful not to drop the washer ① and pin ② into the crankcase.*

- Install the oil pump driven gear ③.
- Install the snap ring ④.

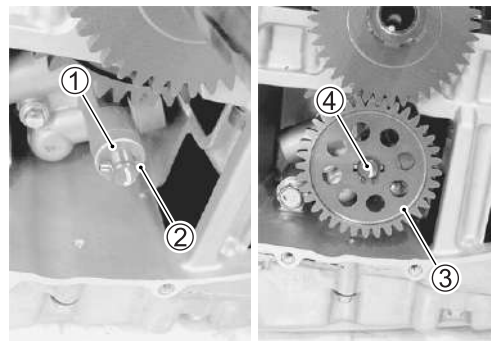
**GEAR POSITION SWITCH**

- Apply SUZUKI SUPER GREASE "A" to the O-ring.

**NOTE:**

*Align the gear position switch pin (A) with the gearshift cam hole (B).*

 **99000-25010: SUZUKI SUPER GREASE "A"**  
or equivalent

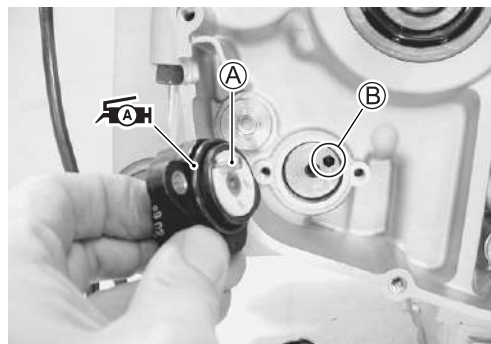

- Install the gear position switch ③ as shown.
- Apply THREAD LOCK SUPER to the gear position switch bolts.

 **99000-32110: THREAD LOCK SUPER "1322"**  
or equivalent

**NOTE:**

*Fit the gromet (C).*

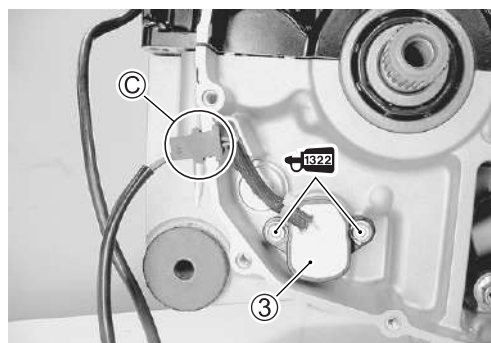

- Hold the primary driven gear with the special tool and tighten its bolt to the specified torque.

 **09930-44541: Rotor holder**

 **Primary driven gear bolt: 95 N·m (9.5 kgf·m, 68.5 lb·ft)**

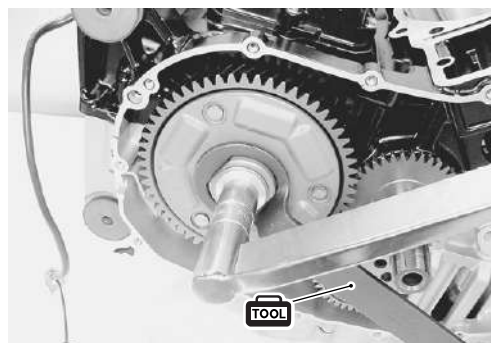



**GEARSHIFT**

- Install the gearshift cam stopper ①, its bolt ②, washer ③ and return spring ④.

**NOTE:**

Apply a small quantity of **THREAD LOCK** to the gearshift cam stopper bolt ② and tighten its to the specified torque.

 **99000-32050: THREAD LOCK "1342" or equivalent**

 **Gearshift cam stopper bolt: 10 N·m (1.0 kgf·m, 7.0 lb-ft)**

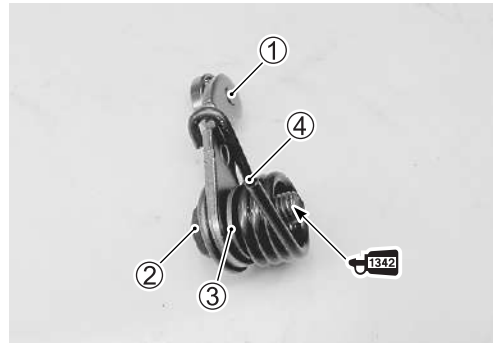
**NOTE:**

Hook the return spring end (A) to the stopper (5).

- Check the gearshift cam stopper moves smoothly.

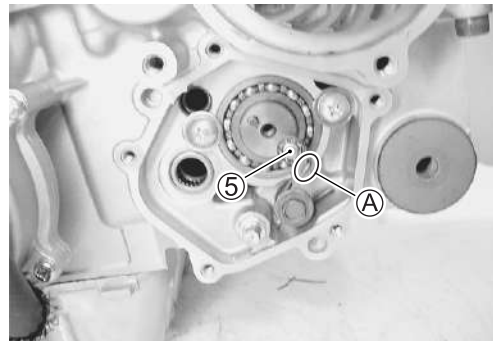

- Install the gearshift cam stopper plate (6).

**NOTE:**

Align the gearshift cam pin (B) with the gearshift cam stopper plate hole (C).

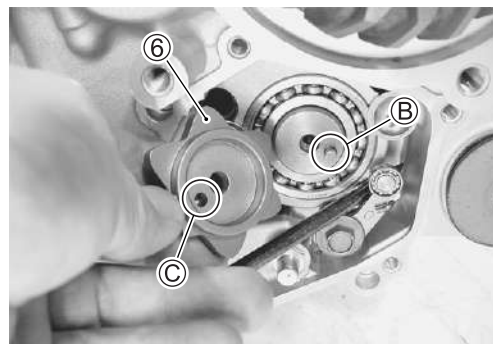

- Apply a small quantity of **THREAD LOCK** to the gearshift cam stopper plate bolt and tighten its to the specified torque.

 **99000-32050: THREAD LOCK "1342" or equivalent**

 **Gearshift cam stopper plate bolt:**  
**13 N·m (1.3 kgf·m, 9.5 lb-ft)**

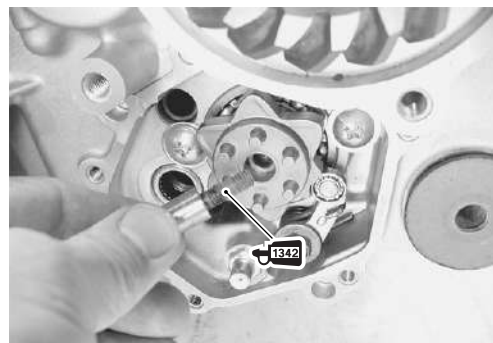

- Install the gearshift shaft assembly (7) as shown.

**NOTE:**

Set the return spring ends (D) to the gearshift arm stopper (8).

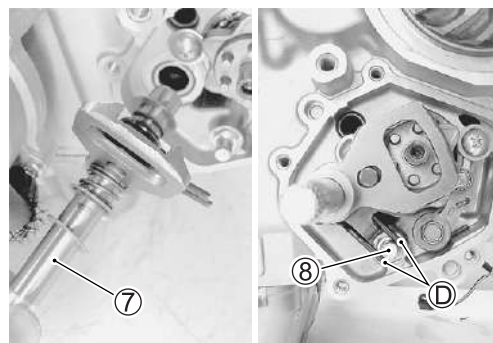



**SECONDARY DRIVE GEAR**

- Change the gear position to the 1st or 2nd.
- Hold the primary driven gear with the special tool.

 **09930-44541: Rotor holder**

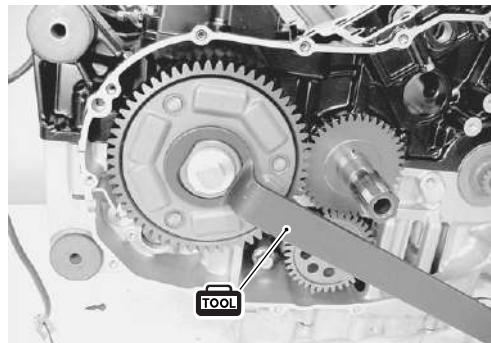

- Apply a small quantity of THREAD LOCK SUPER to the secondary drive gear bolt and tighten its to the specified torque.

 **99000-32030: THREAD LOCK SUPER “1303”**  
or equivalent

 **Secondary drive gear bolt:**  
**160 N·m (16.0 kgf-m, 115.5 lb-ft)**

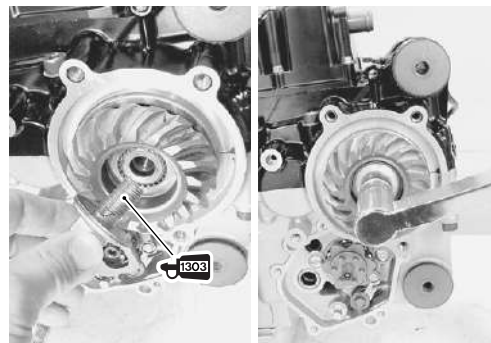
**GEARSHIFT COVER**

- Install the dowel pins and gasket ①.

**CAUTION**

**Use new gasket to prevent oil leakage.**

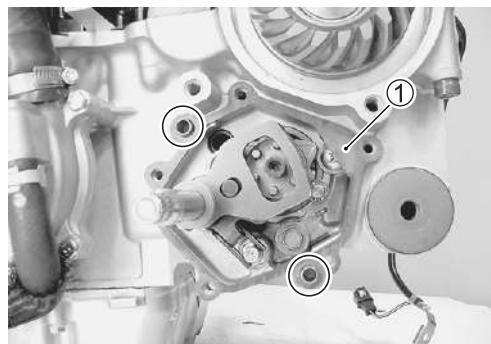

- Install the gearshift cover and tighten its bolts.

**NOTE:**

*Apply grease to the oil seal lip before installing the gearshift cover.*

 **99000-25010: SUZUKI SUPER GREASE “A”**  
or equivalent

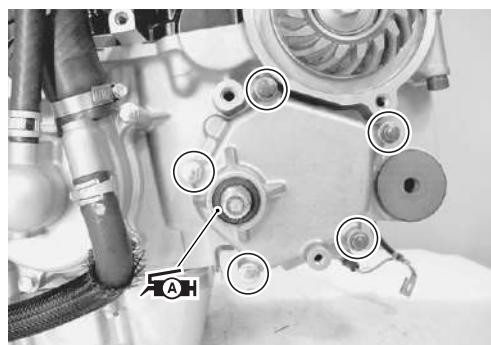

**SECONDARY DRIVEN GEAR**

- Install the shims ① onto the secondary driven gear case.  
( 4-11)
- Fit the O-ring ② and apply engine oil.

**CAUTION**

**Use the new O-ring to prevent oil pressure leak.**

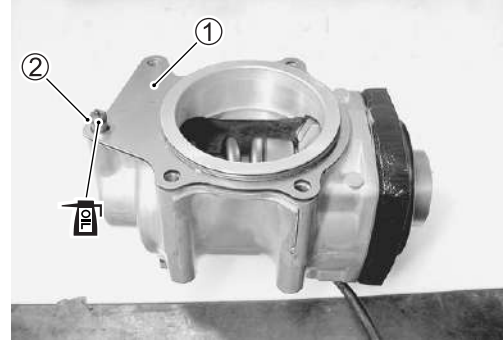

- Install the secondary driven gear case ③ with the bolts and then tighten them to the specified torque.

 **Secondary driven gear case bolt:**  
**26 N·m (2.6 kgf-m, 19.0 lb-ft)**

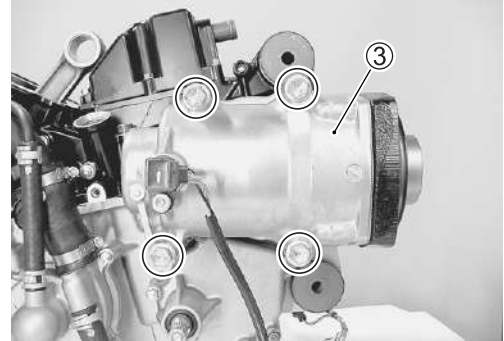
**NO. 1 FRONT CAM CHAIN TENSION ADJUSTER**

- After unlocking the ratchet, push the cam chain tension adjuster rod.
- Insert the special tool between the ratchet and the adjuster body.

 **09918-53810: Chain tensioner lock tool**



- Install the front cam chain tension adjuster No. 1 with the bolts and tighten its bolts to the specified torque.

 **Front cam chain tension adjuster No. 1 bolt:**  
**10 N·m (1.0 kgf-m, 7.0 lb-ft)**



**FRONT CAM DRIVE IDLE GEAR/SPROCKET**

- Turn the crankshaft counterclockwise with the box wrench and align “R I T” line (A) on the crankshaft with the index marks (B) of the upper crankcase hole.

**CAUTION**

To adjust the camshaft timing correctly, be sure to align “R I T” line (A) with the index marks (B) and hold this position when installing the cam drive idle gears/sprockets, front and rear.

- Install the front cam chain tensioner No. 1 assy (1).
- Apply a small quantity of THREAD LOCK SUPER to the bolt and tighten its to the specified torque.

 **99000-32030: THREAD LOCK SUPER “1303” or equivalent**

 **Front chain tensioner No. 1 bolt:**  
**18 N·m (1.8 kgf·m, 13.0 lb-ft)**

- Engage the cam chain No. 1 onto the cam drive idler sprocket and install it to the upper crankcase.
- Align the groove (A) on the cam idler sprocket with the embossed line (B) on the upper crankcase. ( 3-94)

- Apply SUZUKI MOLY PASTE to the idler shaft (2) and install the idler shaft.

 **MOLYBDENUM OIL SOLUTION**

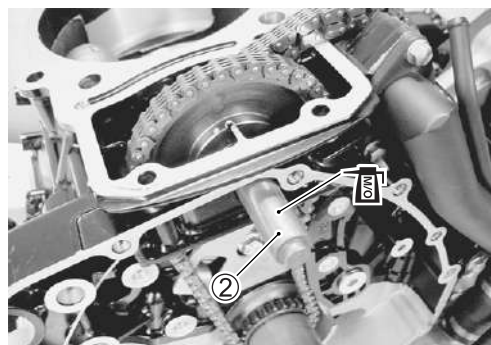
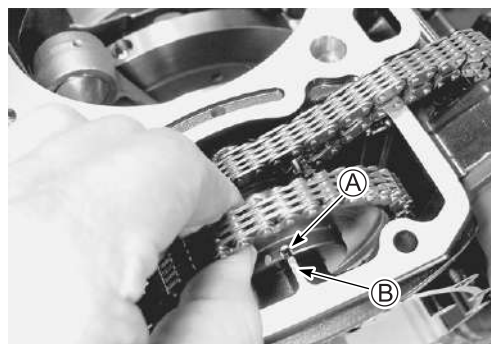
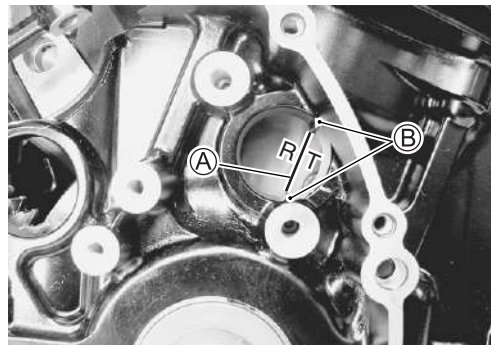

- Install the cam chain guide No. 1 ③.
- Apply a small quantity of THREAD LOCK SUPER to the bolts and tighten its to the specified torque.

 **99000-32030: THREAD LOCK SUPER “1303” or equivalent**

 **Cam chain guide No. 1 bolt: 18 N·m (1.8 kgf·m, 13.0 lb-ft)**

- Remove the tensioner lock tool.

**NOTE:**

*Click sound is heard when the cam chain tension adjuster is released.*

**GENERATOR**

- Degrease the tapered portion of the generator rotor assembly and also the crankshaft. Use nonflammable cleaning solvent to wipe off the oily or greasy matter to make these surfaces completely dry.
- Install the key ①.

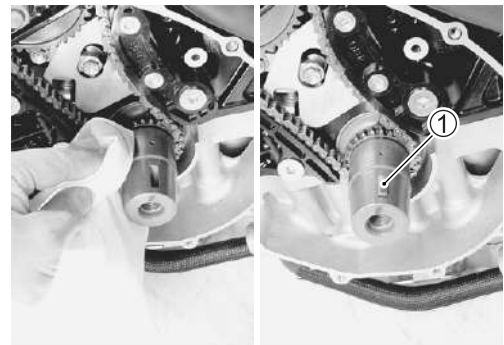
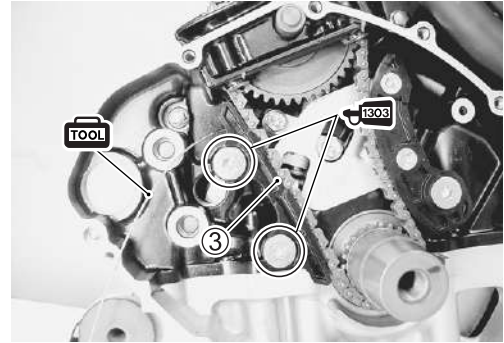

- Install the generator rotor assembly.
- Tighten the generator rotor bolt to the specified torque.

 **Generator rotor bolt: 160 N·m (16.0 kgf·m, 115.5 lb-ft)**



**REAR CAM CHAIN DRIVE SPROCKET**

- Install the rear cam chain drive sprocket ① onto the crankshaft.

**NOTE:**

*When installing the cam chain drive sprocket, align the wide spline teeth ① and ②.*

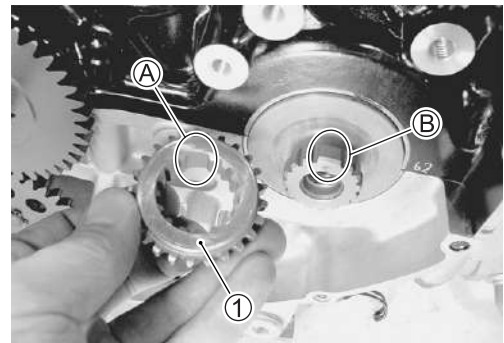

- Install the rear cam chain drive sprocket bolt with the washer.
- Hold the generator rotor and tighten its bolt to the specified torque.

 **Rear cam chain drive sprocket bolt: 85 N·m (8.5 kgf·m, 61.5 lb-ft)**

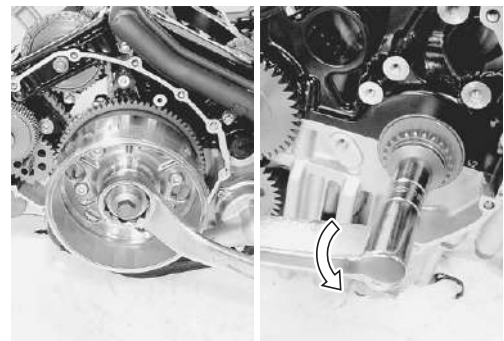



**STARTER TORQUE LIMITER/STARTER IDLE GEAR**

- Install the starter idle gear ① and shaft ②.

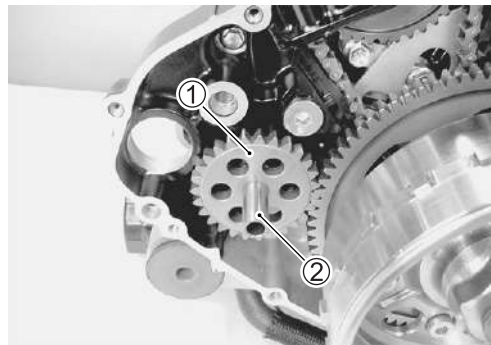

- Install the bushings ③ into the crankcase and generator cover.

**NOTE:**

Apply molybdenum oil solution to the inside of the bushings.

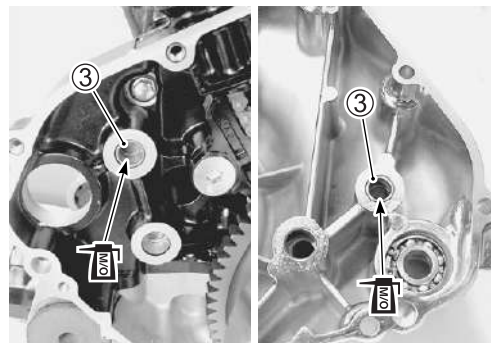
 **MOLYBDENUM OIL SOLUTION**

- Fit the washers ④ onto the starter torque limiter ⑤.
- Install the starter torque limiter ⑤ to the crankcase.

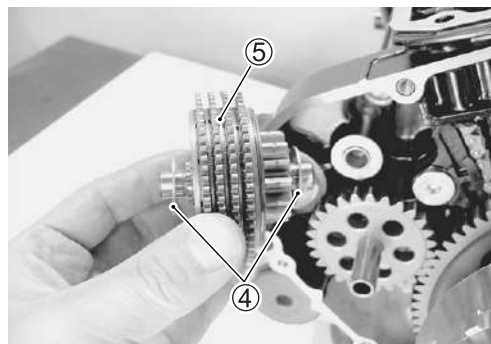
**REAR CAM CHAIN IDLER SPROCKET**

- Engage the cam chain No. 1 onto the cam drive idler sprocket and it to the upper crankcase.
- Align the groove ① on the cam idler sprocket with the embossed line ② on the upper crankcase. (↖ 3-94)

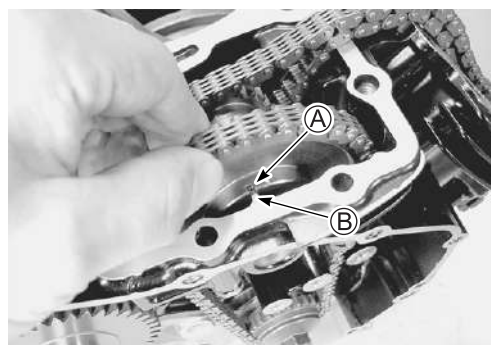

- Apply SUZUKI MOLY PASTE to the idler shaft ① and install the idler shaft.

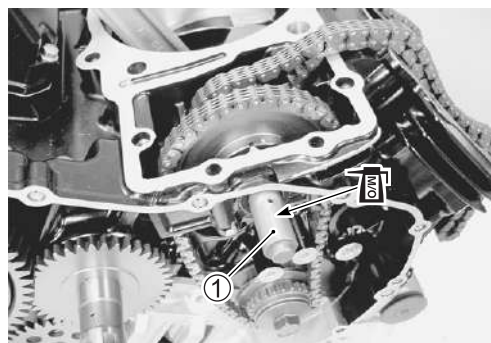
 **MOLYBDENUM OIL SOLUTION**

- After unlocking the ratchet, push the cam chain tension adjuster rod.
- Insert the special tool between the ratchet and the adjuster body.

 **09917-62430: Chain tensioner lock tool**

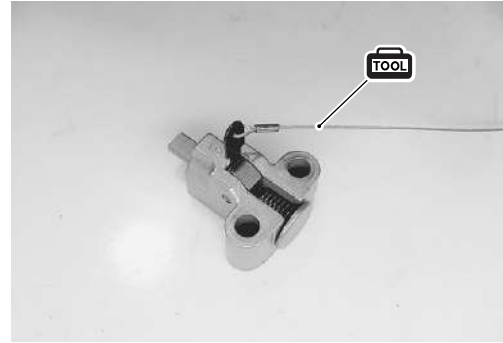

- Install the rear cam chain tension adjuster No. 1 with the bolts and tighten its bolts to the specified torque.

 **Rear cam chain tension adjuster No. 1 bolt:**  
**10 N·m (1.0 kgf-m, 7.0 lb-ft)**



- Install the cam chain guide No. 1 ①, rear cam chain tensioner No. 1 assy ②.
- Apply a small quantity of THREAD LOCK SUPER to the bolts and tighten its to the specified torque.

 **99000-32030: THREAD LOCK SUPER "1303"**  
**or equivalent**

 **Cam chain guide No. 1 bolt: 18 N·m (1.8 kgf-m, 13.0 lb-ft)**  
**Rear cam chain tensioner No. 1 bolt:**  
**18 N·m (1.8 kgf-m, 13.0 lb-ft)**

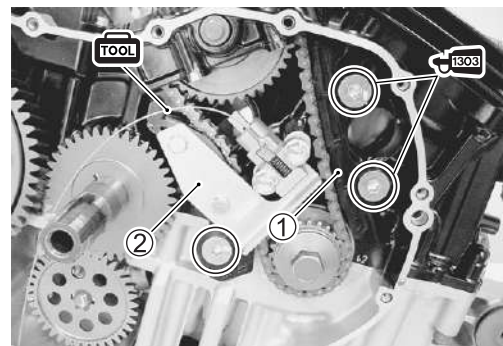

- Remove the tensioner lock tool.

**NOTE:**

*Click sound is heard when the cam chain tension adjuster is released.*

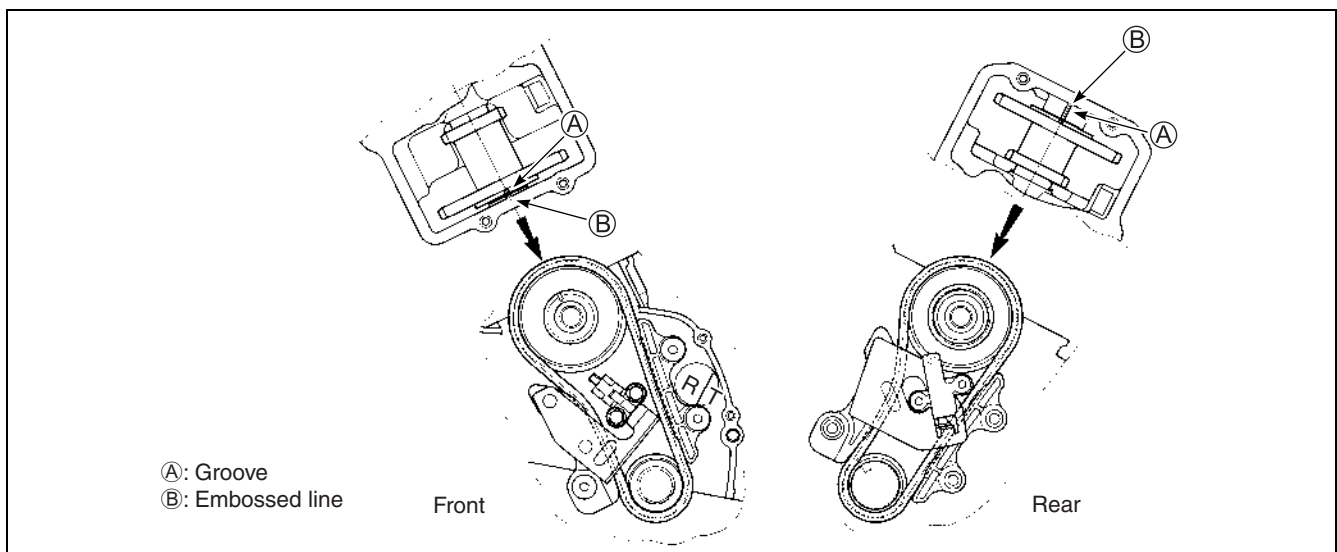



**CLUTCH**

- Install the needle bearing ① and spacer ② onto the counter-shaft.
- Apply engine oil to them.

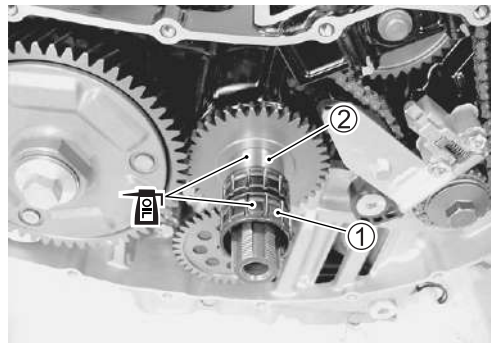

- Install the primary driven gear assembly ③ onto the counter-shaft.
- Install the thrust washer ④.

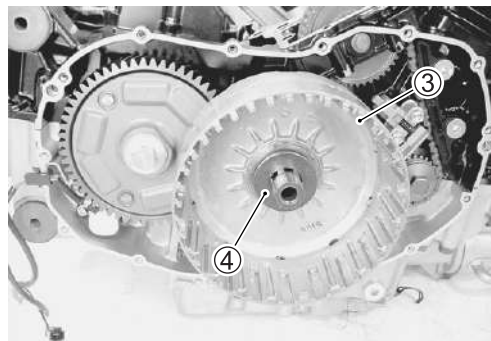

- Install the clutch sleeve hub assembly ⑤ onto the counter-shaft.
- Install the spring washer ⑥.

**NOTE:**

*The conical curve side of spring washer ⑥ faces outside.*

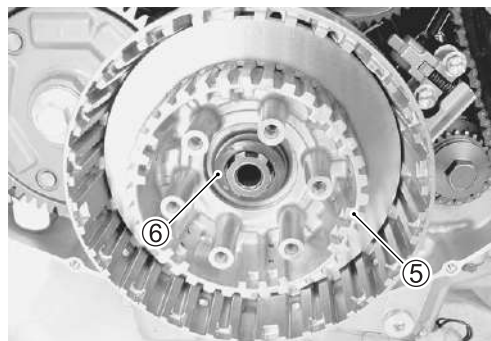

- Hold the generator rotor and tighten the clutch sleeve hub nut to the specified torque.

**🔧 Clutch sleeve hub nut: 95 N·m (9.5 kgf-m, 68.5 lb-ft)**

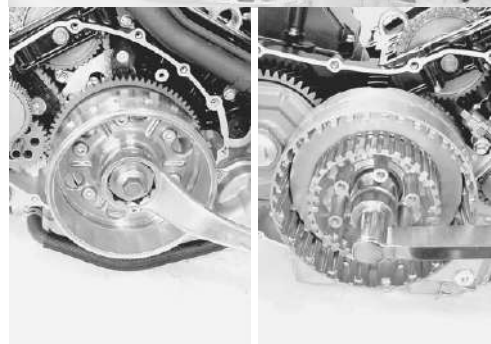

- Lock the clutch sleeve hub nut with a center punch.



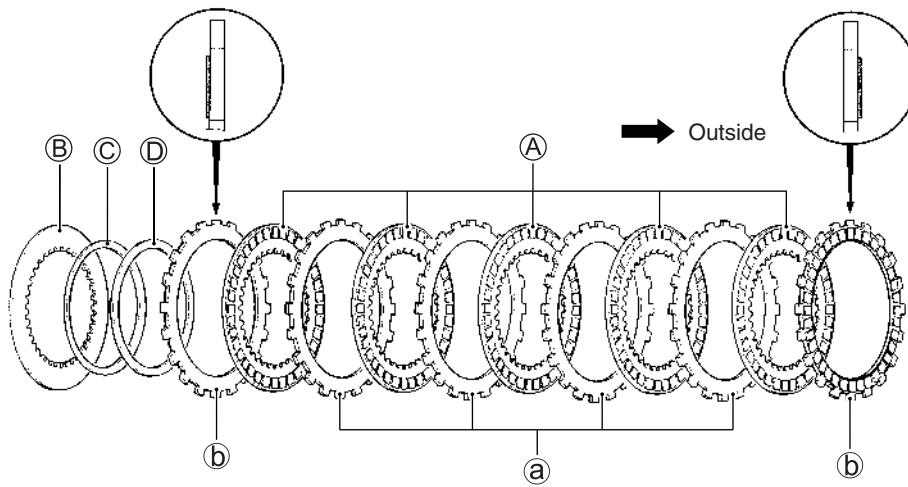

**DRIVE PLATE:**

- (A) Drive plate No. 1 .....5 pcs.
- (B) Drive plate No. 2 .....1 pc.
- (C) Wave washer
- (D) Wave washer seat

**DRIVEN PLATE:**

- (a) Driven plate No. 1 .....4 pcs.
- (b) Driven plate No. 2 .....2 pcs.

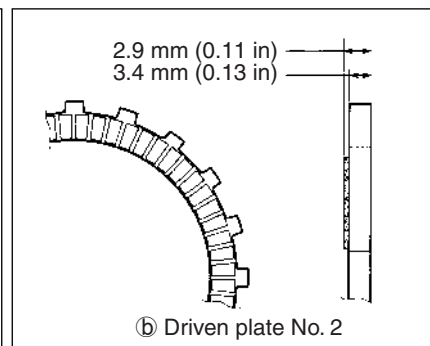
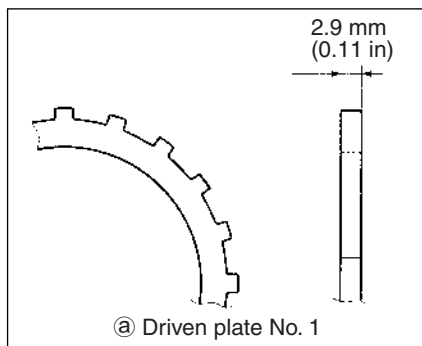
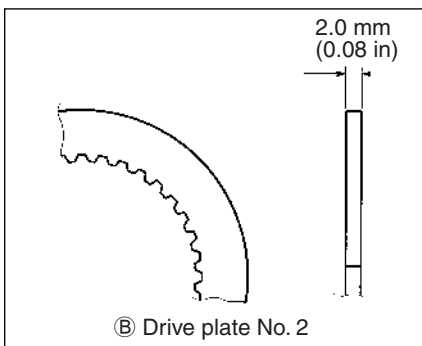
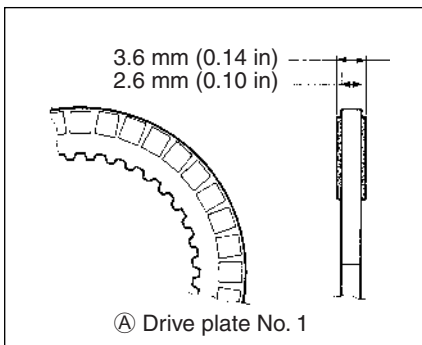
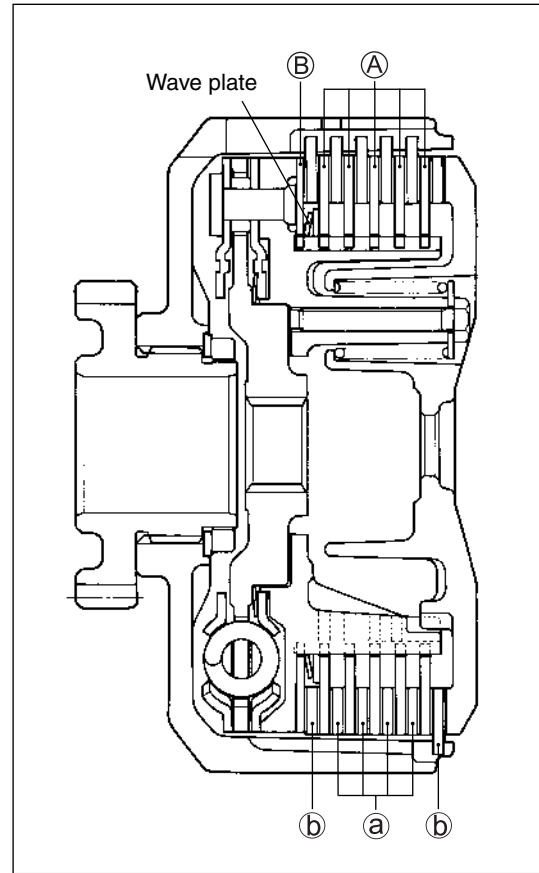

- Install the drive plate No. 2 ⑦, spring washer ⑧ and spring washer seat ⑨ onto the clutch sleeve hub correctly.

**NOTE:**

*The conical curve side of spring washer ⑧ faces outside.*

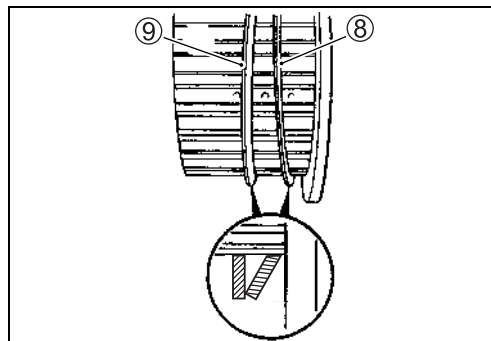
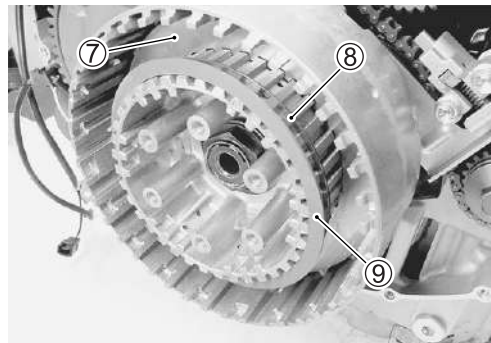

- Insert the clutch drive plates and driven plates one by one to the clutch sleeve hub after applying engine oil to the them.

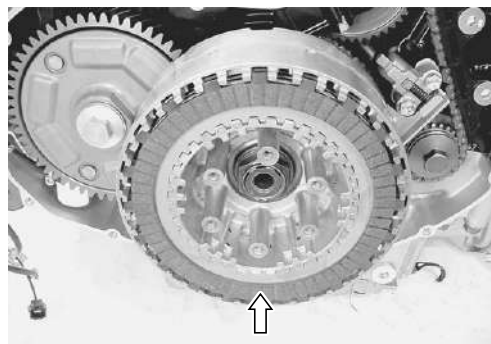

- Install the clutch push rod release ball ⑩ and clutch push rod ⑪ into the countershaft.

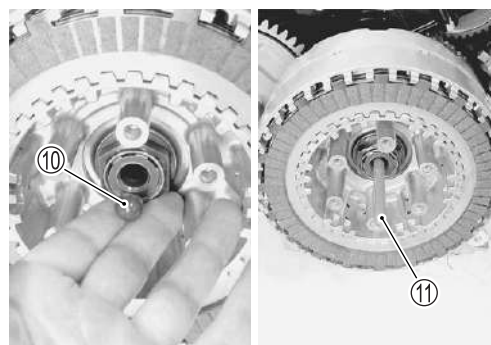

- Install the clutch push piece ⑫, bearing ⑬ and thrust washer ⑭.

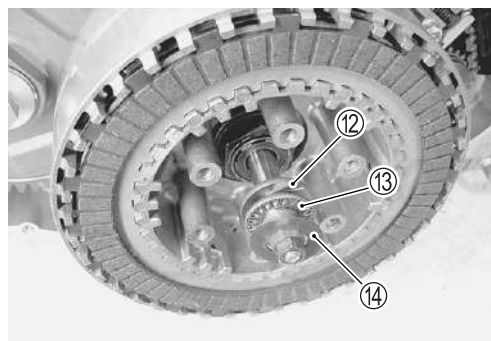

- Tighten the clutch spring set bolts securely while holding the generator rotor.

**NOTE:**

*Tighten the clutch spring bolts diagonally.*

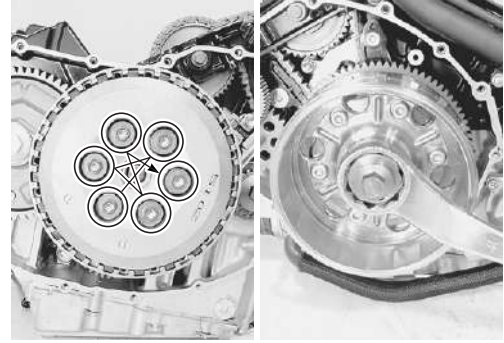

**PISTON RING**

- Install the piston rings in the order of oil ring, 2nd ring and 1st ring.
- The first member to go into the oil ring groove is a spacer ①. After placing the spacer, fit the two side rails ②.

**NOTE:**

*Side designations, top and bottom, are not applied to the spacer and side rails: you can position each either way.*

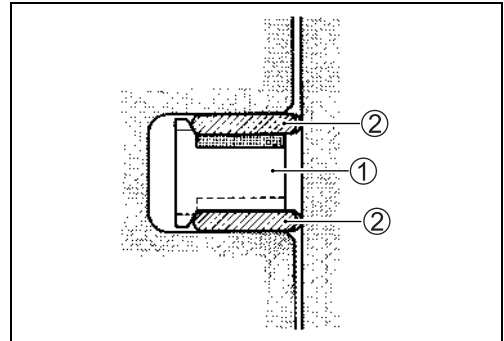

**CAUTION**

**When installing the spacer, be careful not to allow its two ends to overlap in the groove.**

- Ⓐ INCORRECT
- Ⓑ CORRECT

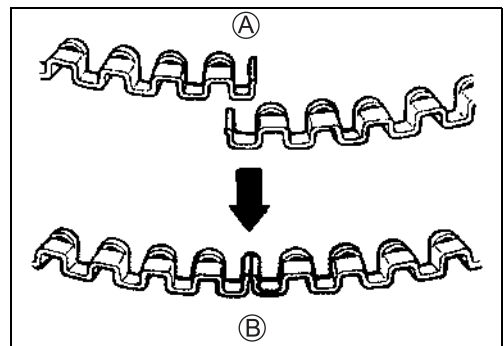

- Install the 2nd ring ③ and the 1st ring ④ to the piston.

**NOTE:**

*1st ring and 2nd ring differ in shape.*

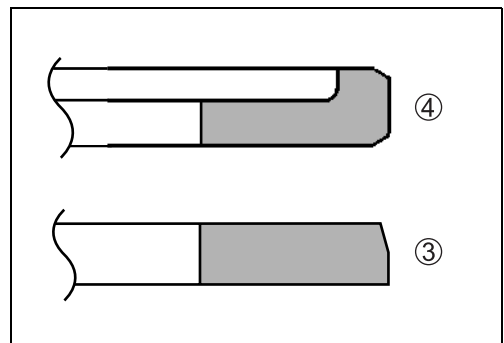

- Be sure to bring the concave side of 1st ring to the top when fitting it to the piston.
- 2nd ring has letters “RN” marked on the side. Be sure to bring the marked side to the top when fitting it to the piston.

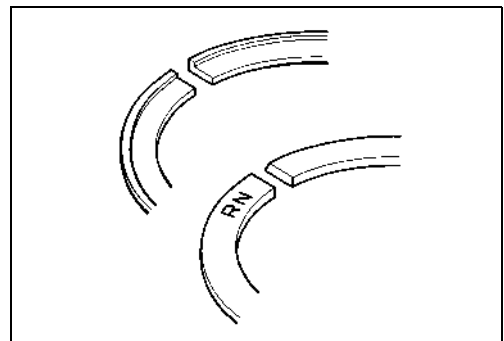

- Position the gaps of the three ring as shown. Before inserting each piston into the cylinder, check that the gaps are so located.

- Ⓒ 2nd ring and lower side rail
- Ⓓ Upper side rail
- Ⓔ 1st ring and spacer

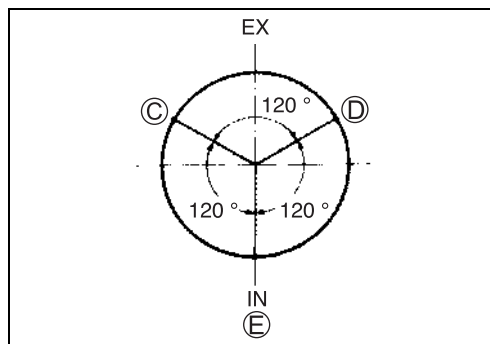

- Apply a small quantity of MOLYBDENUM OIL SOLUTION onto each piston pins, front and rear.

#### **MOLYBDENUM OIL SOLUTION**

- Assemble the pistons and conrods, front and rear.

#### **NOTE:**

When installing the pistons, front and rear, the indents **A** on the piston heads must be located to each exhaust side.

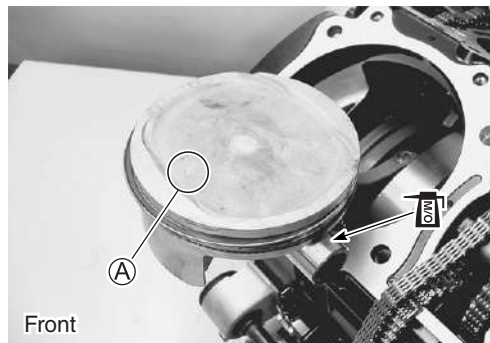

- Place a clean rag over the cylinder base so as not to drop the piston pin circlips into the crankcase.
- Install the piston pin circlips, front and rear.

#### **CAUTION**

**Use new piston pin circlips to prevent circlip failure which will occur with a bend one.**

#### **NOTE:**

End gap of the circlip should not be aligned with the cutaway in the piston pin bore.

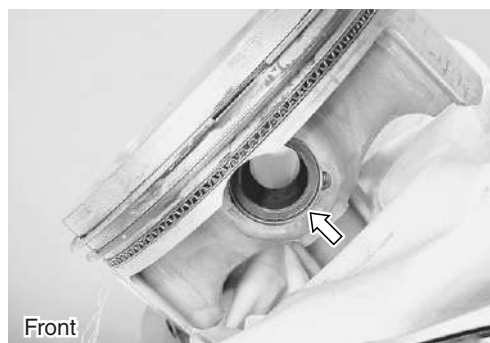



**CYLINDER**

- Fit the dowel pins and new gaskets ① to the crankcase front and rear.

**CAUTION**

**Use the new gaskets to prevent oil leakage.**

- Apply a small quantity of MOLYBDENUM OIL SOLUTION to the sliding surface of the pistons and cylinder walls.

 **MOLYBDENUM OIL SOLUTION**
**NOTE:**

The cylinders can be distinguished by the embossed-letters, "FR" and "RR".

"FR": Front (#2) cylinder

"RR": Rear (#1) cylinder

- Hold the piston rings in proper position, and insert each of the pistons into the respective cylinders.
- Tighten the cylinder nuts temporarily.

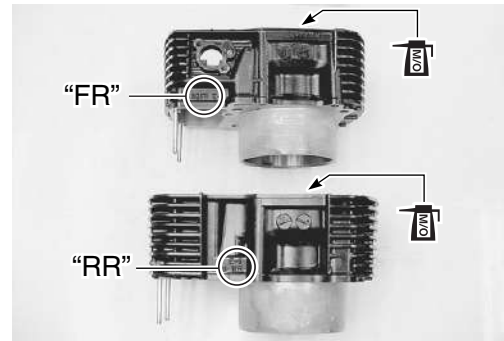
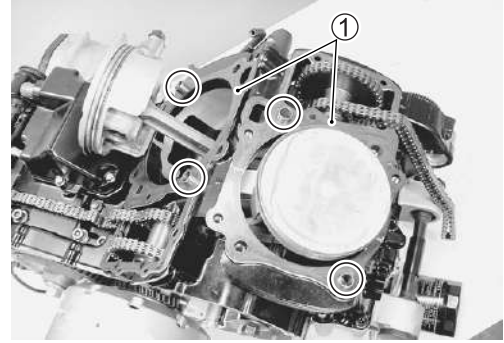
**CYLINDER HEAD**

- Pull the cam chains out of the cylinders and install the cam chain guides No. 2 ①.

**NOTE:**

There are the guide holders for the bottom ends of each cam chain guide cast in the crankcase. Be sure that the cam chain guides are inserted properly.

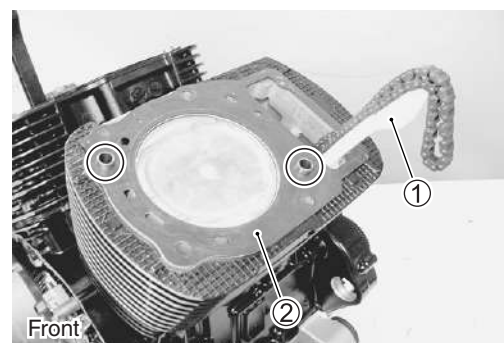



- Fit the dowel pins and new cylinder head gaskets ② to the cylinders, front and rear.

**CAUTION**

Use the new gaskets to prevent gas leakage.

**NOTE:**

The cylinder heads can be distinguished by the embossed-letters, "F" and "R".

"F": Front (#2) cylinder

"R": Rear (#1) cylinder

- Place the front and rear cylinder head on the cylinder.

**NOTE:**

When installing the cylinder head, keep the cam chain taut.

- Tighten the cylinder head bolts (M10) to the specified two step torque with a torque wrench sequentially and diagonally.

 **Cylinder head bolt (M10):**

**Initial 25 N·m (2.5 kgf-m, 18.0 lb-ft)**

**Final 42 N·m (4.2 kgf-m, 30.5 lb-ft)**

- Tighten the other bolts (M6) and (M8) to the a little at a time to equalize the pressure.

 **Crankcase bolt: (M6) 11 N·m (1.1 kgf-m, 8.0 lb-ft)**  
**(M8) 26 N·m (2.6 kgf-m, 19.0 lb-ft)**

**NOTE:**

Apply engine oil to the both side of washers ① and thread portion of the bolts before installing the cylinder head bolts.

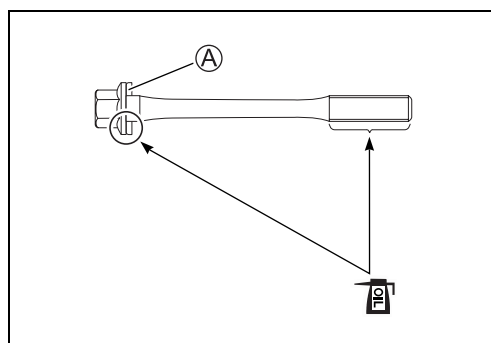
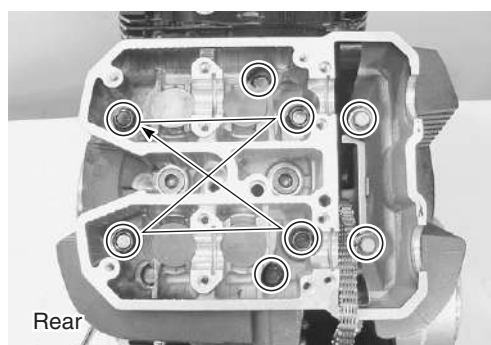
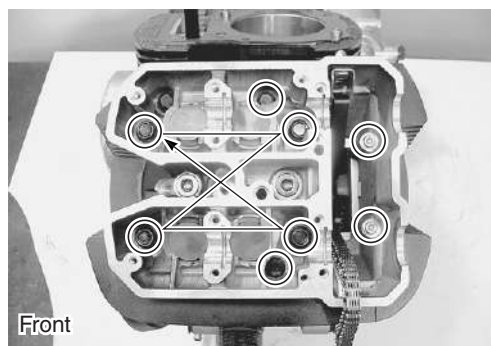
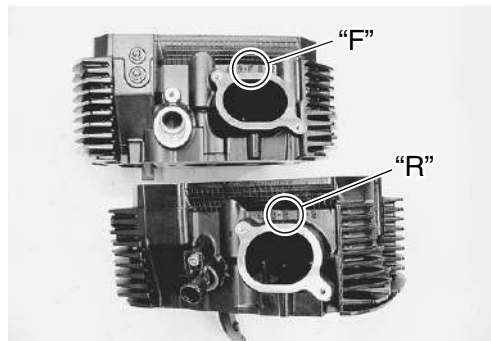
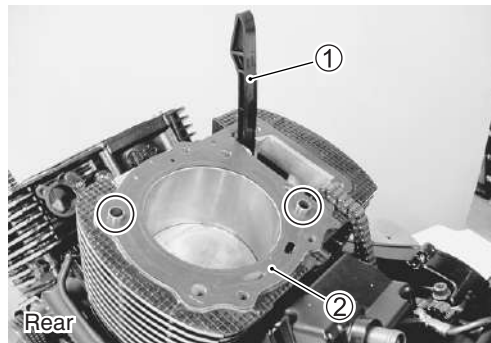

①: 8 mm and 10 mm bolts

- Tighten the front and rear cylinder nuts to the specified torque.

 **Cylinder nut: 13 N·m (1.3 kgf-m, 9.5 lb-ft)**

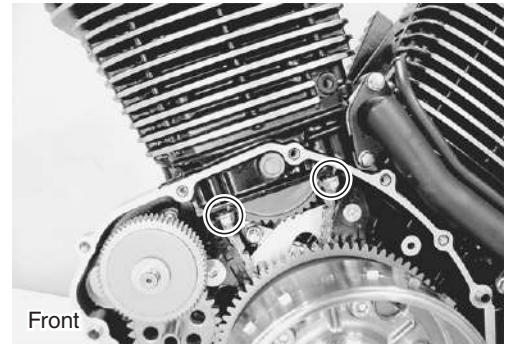

### FRONT CAMSHAFTS

- Turn the crankshaft counterclockwise approx. 1-1/3 turns (486°) with the box wrench and align “F I T” line **(A)** on the crankshaft with the index marks **(B)** of the upper crankcase hole while keeping the camshaft drive chain pulled upward.

#### CAUTION

**Pull the cam chains upward, or the chain will be caught between crankcase and cam drive sprocket.**

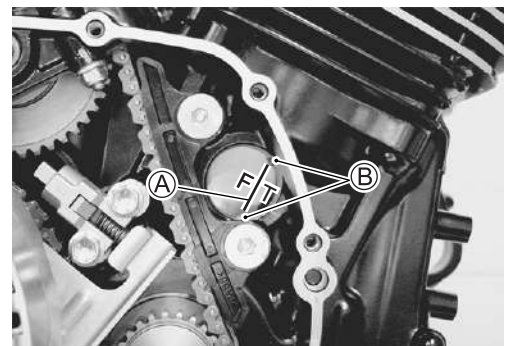

#### CAUTION

**To adjust the camshaft timing correctly, be sure to align “F I T” line **(A)** with the index marks **(B)** and hold this position when installing the camshafts.**

- The camshafts are identified by the embossed letters.
- Before replacing the camshafts on cylinder head, apply MOLYBDENUM OIL SOLUTION to their journals and cam faces.
- Apply a MOLYBDENUM OIL SOLUTION to the camshaft journal holders.

### MOLYBDENUM OIL SOLUTION

#### NOTE:

*Before installing the camshaft, check that the tappets are installed correctly.*

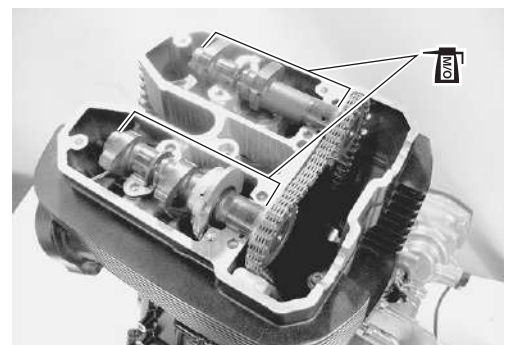

- Pull the cam chain lightly.
- The exhaust camshaft sprocket has an arrow marked "1" ①. Turn the exhaust camshaft so that the arrow is aligned with the gasket surface of the cylinder head.
- Engage the cam chain with the exhaust camshaft sprocket.
- Starting from the roller pin that is directly above the arrow marked "2" ②, count out 18 roller pins (from the exhaust camshaft side going towards the intake camshaft side).
- Engage the 18th roller pin ③ on the cam chain with the arrow marked "3" on the intake sprocket.

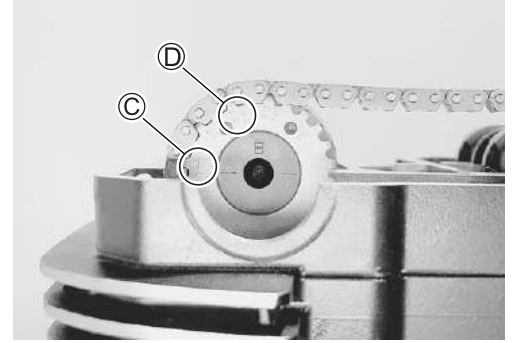

**NOTE:**

*The cam chain should now be on all three sprockets. Be careful not to move the crankshaft until the camshaft journal holders and cam chain tension adjuster are secured.*

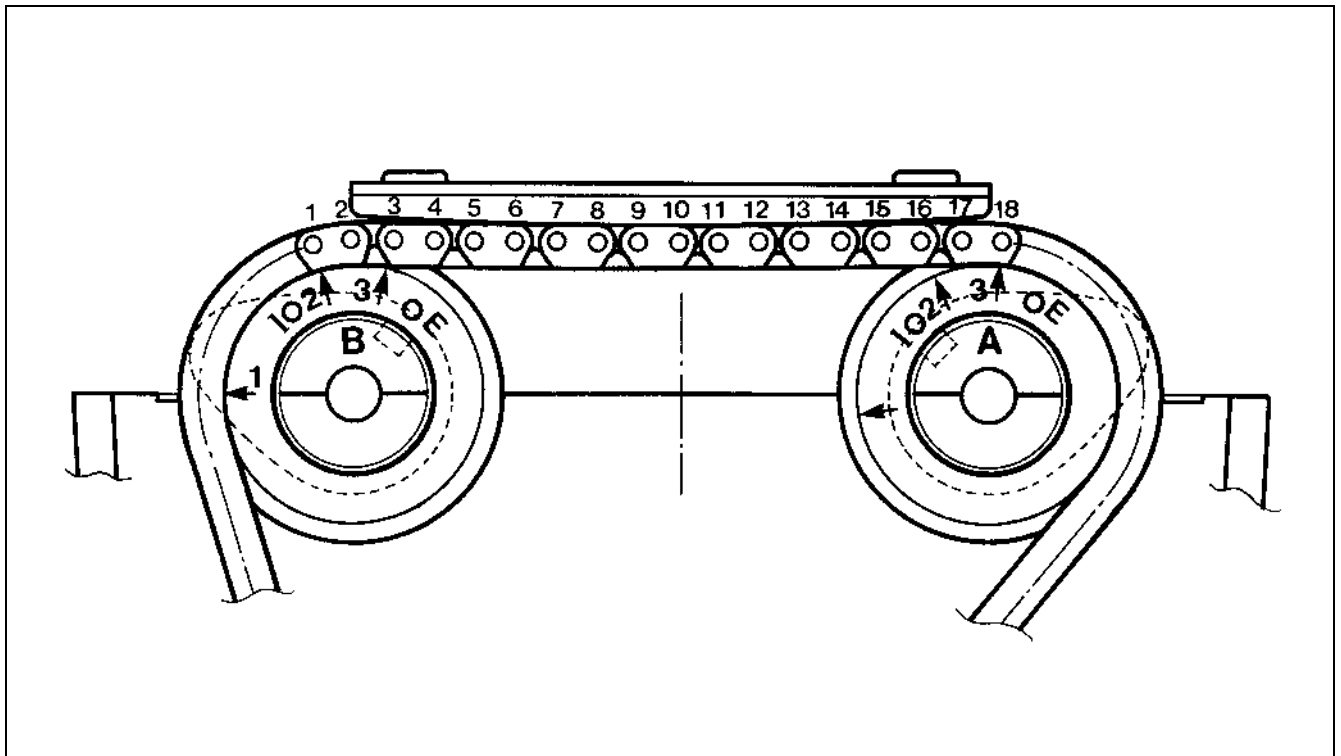
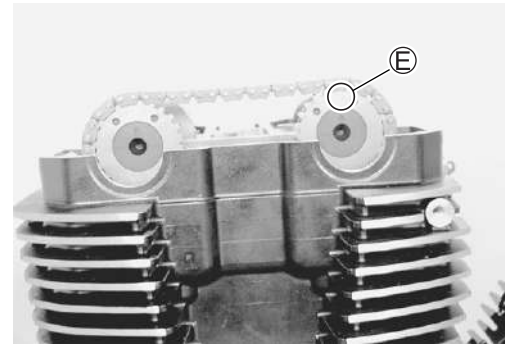

- Install the dowel pins.
- Install the camshaft journal holders, intake and exhaust ①, and cam chain guide No. 3 ②.
- Have the camshaft journal holders seated evenly by tightening the camshaft journal holder bolts lightly, in the ascending order of numbers.

**NOTE:**

- \* *Damage to head or camshaft journal holder thrust surfaces may result if the camshaft journal holders are not drawn down evenly.*
- \* *Each camshaft journal holder is identified with a cast-on letter F (IN. & EX.).*
- \* *The ascending order of numbers are indicated on the camshaft journal holder.*
- Tighten the camshaft journal holder bolts in ascending order of numbers to the specified torque.

 **Camshaft journal holder bolt: 11 N·m (1.1 kgf·m, 8.0 lb-ft)**

**CAUTION**

- \* **The camshaft journal holder bolts are made of a special material and much superior in strength, compared with other types of high strength bolts.**
- \* **Take special care not to use other types of bolts.**

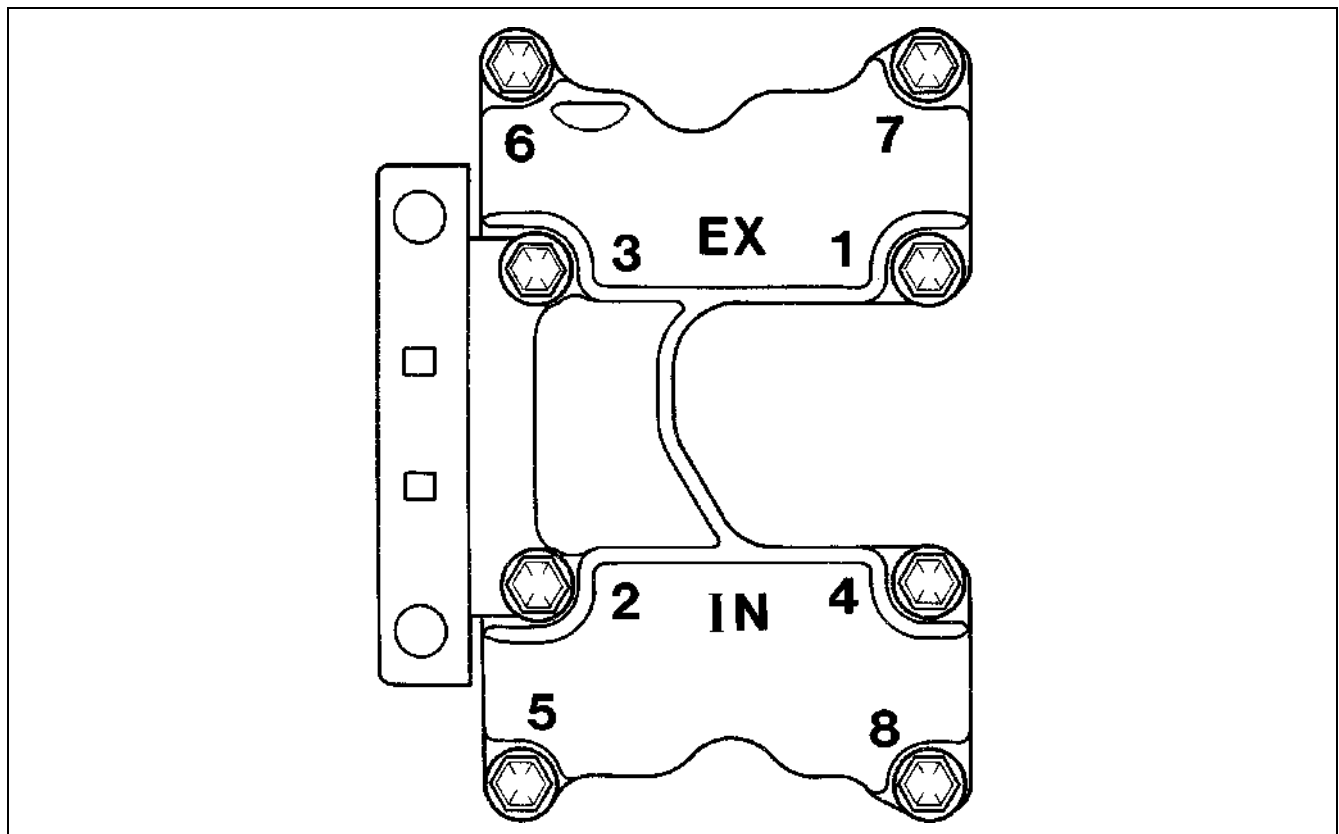
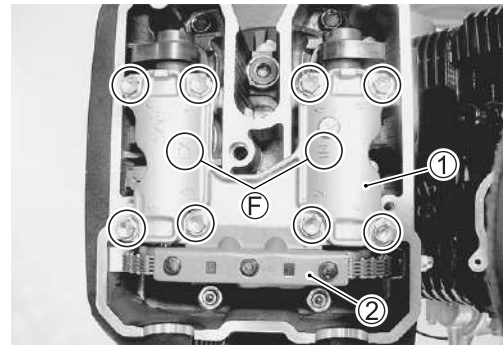
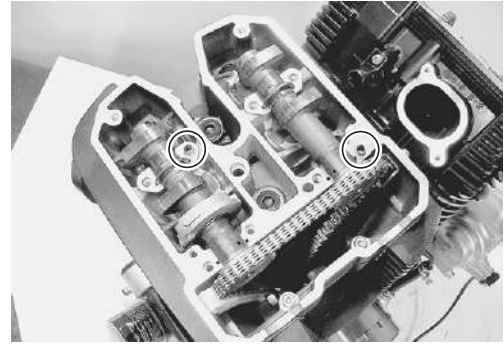

## REAR CAMSHAFTS

- From the position where the front camshafts have now been installed, rotate the generator rotor approx.  $2/3$  turn ( $234^\circ$ ) and align the “R I T” line **(A)** on the crankshaft with the index marks **(B)** of the upper crankcase hole.

### CAUTION

- \* Pull the cam chain upward, or the chain will be caught between crankcase and cam drive sprocket.
- \* To adjust the camshaft timing correctly, be sure to align “R I T” line **(A)** with the index mark **(B)** and hold this position when installing the camshafts.

- The camshafts are identified by the embossed letters.
- Before replacing the camshafts on cylinder head, apply MOLYBDENUM OIL SOLUTION to their journals and cam faces.
- Apply a MOLYBDENUM OIL SOLUTION to the camshaft journal holders.

### MOLYBDENUM OIL SOLUTION

#### NOTE:

Before installing the camshaft, check that the tappets are installed correctly.

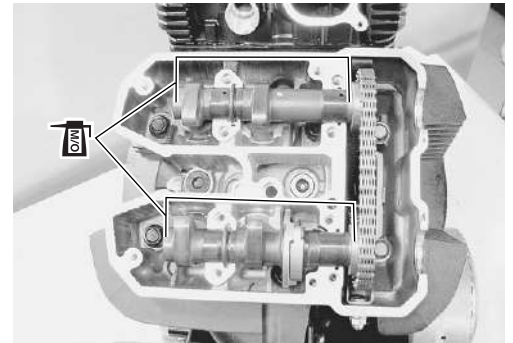
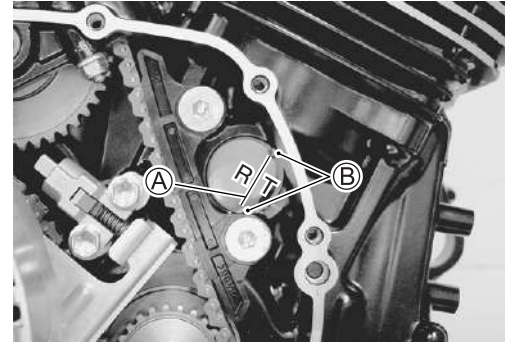



- Pull the cam chain lightly.
- The intake camshaft sprocket has an arrow marked "1" ③. Turn the intake camshaft so that the arrow is aligned with the gasket surface of the cylinder head.
- Engage the cam chain with the intake camshaft sprocket.
- The other arrow marked "2" ④ should now be pointing straight up. Starting from the roller pin that is directly above the arrow marked "2" ④, count out 18 roller pins (from the intake camshaft side going towards the exhaust camshaft side).
- Engage the 18th roller pin ⑤ on the cam chain with the arrow marked "3" on the exhaust sprocket.

**NOTE:**

*The cam chain should now be on all three sprockets. Be careful not to move the crankshaft until the camshaft journal holders and cam chain tension adjuster are secured.*

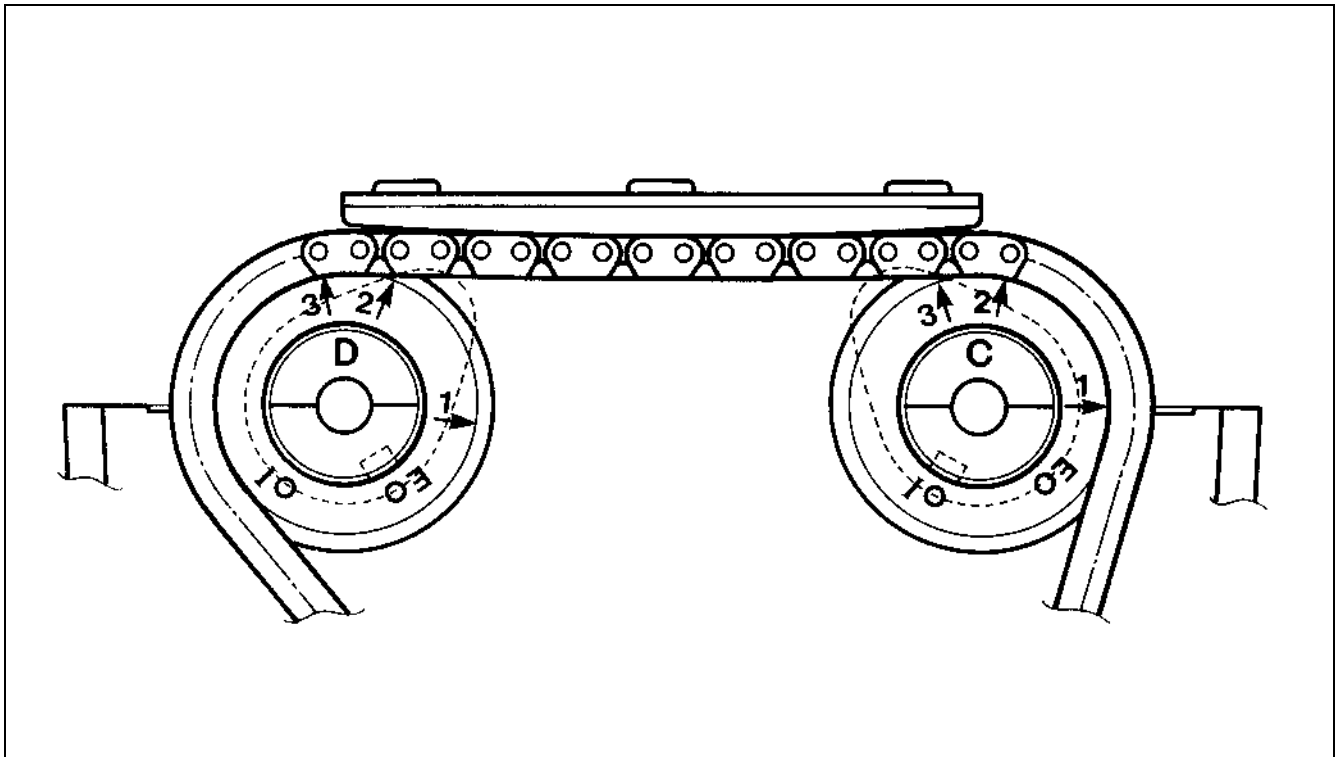
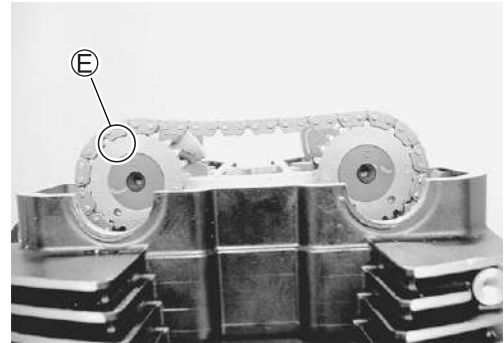
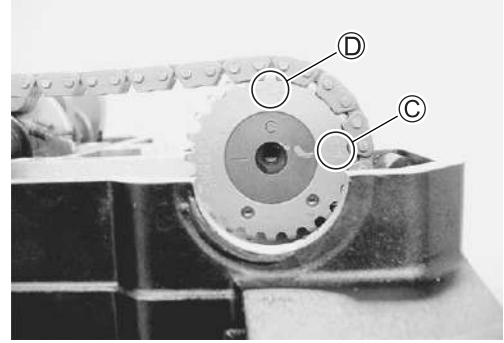



- Install the dowel pins.
- Install the camshaft journal holders, intake and exhaust ①, and cam chain guide No. 3 ②.
- Have the camshaft journal holders seated evenly by tightening the camshaft journal holder bolts lightly, in the ascending order of numbers.

**NOTE:**

- \* *Damage to head or camshaft journal holder thrust surfaces may result if the camshaft journal holders are not drawn down evenly.*
- \* *Each camshaft journal holder is identified with a cast-on letter  $\text{\textcircled{F}}$  (IN. & EX.).*
- \* *The ascending order of numbers are indicated on the camshaft journal holder.*
- Tighten the camshaft journal holder bolts in ascending order of numbers to the specified torque. (☞ 3-104)

**🔧 Camshaft journal holder bolt: 11 N·m (1.1 kgf-m, 8.0 lb-ft)**

**CAUTION**

- \* **The camshaft journal holder bolts are made of a special material and much superior in strength, compared with other types of high strength bolts.**
- \* **Take special care not to use other types of bolts.**

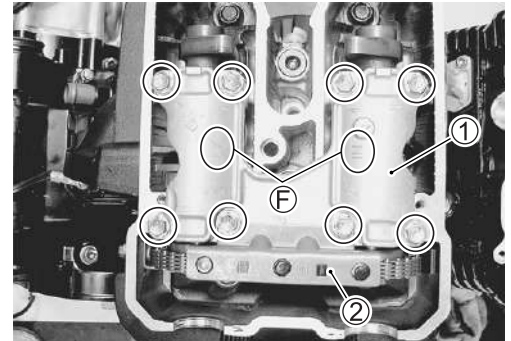
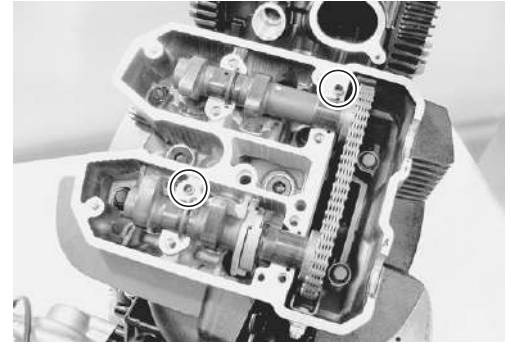
**REAR CAM CHAIN TENSION ADJUSTER**

- The cam chain tension adjuster are identified by the embossed letters (R-UP).
- Retract the push rod by pushing the stopper ①.

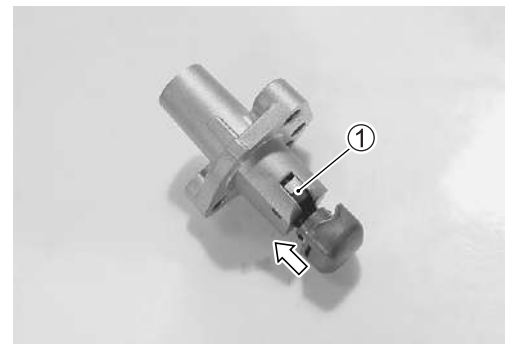

- Install a new gasket ②.

**CAUTION**

**Use a new gasket to prevent oil leakage.**

- Install the cam chain tension adjuster ③ and tighten its mounting bolts.

**🔧 Cam chain tension adjuster mounting bolt: 10 N·m (1.0 kgf-m, 7.0 lb-ft)**

- Install the spring ④.

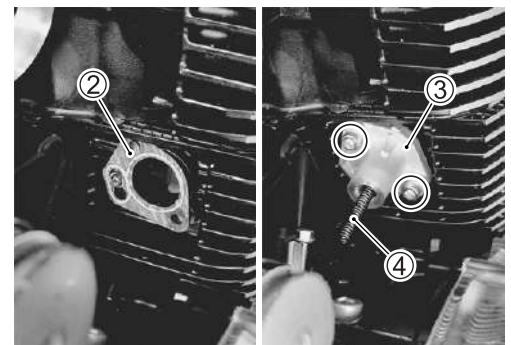

- Install the gasket ⑤ and cam chain tension adjuster cap bolt ⑥.

**NOTE:**

*Click sound is heard when the cam chain tension adjuster cap bolt is installed.*

- Tighten the cam chain tension adjuster cap bolt to the specified torque.

**🔩 Cam chain tension adjuster cap bolt:**  
23 N·m (2.3 kgf·m, 16.5 lb·ft)

**CAUTION**

After installing the cam chain tension adjuster, check to be sure that the adjuster works properly by checking the slack of cam chain.

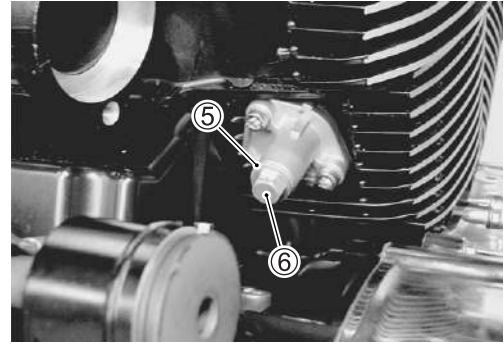
**FRONT CAM CHAIN TENSION ADJUSTER**

- The cam chain tension adjuster are identified by the embossed letters (F-UP).
- Retract the push rod by pushing the stopper ①.



- Install a new gasket ②.

**CAUTION**

Use a new gasket to prevent oil leakage.

- Install the cam chain tension adjuster ③ and tighten its mounting bolts.

**🔩 Cam chain tension adjuster mounting bolt:**  
10 N·m (1.0 kgf·m, 7.0 lb·ft)

- Install the spring ④.

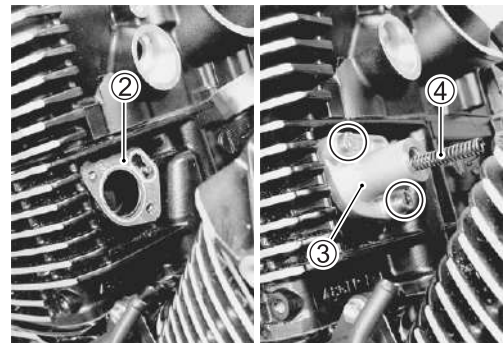

- Install the gasket ⑤ and cam chain tension adjuster cap bolt ⑥.

**NOTE:**

*Click sound is heard when the cam chain tension adjuster cap bolt is installed.*

- Tighten the cam chain tension adjuster cap bolt to the specified torque.

 **Cam chain tension adjuster cap bolt:**

**23 N·m (2.3 kgf·m, 16.5 lb-ft)**

**CAUTION**

**After installing the cam chain tension adjuster, check to be sure that the adjuster works properly by checking the slack of cam chain.**

- After installing the cam chain tension adjuster, rotate the crankshaft (some turns), and recheck the positions of the camshafts. (☞ 3-106)

**FRONT AND REAR CYLINDER HEAD COVER**

- Pour engine oil in each oil pocket in the cylinder heads.

**NOTE:**

*Be sure to check the valve clearance. (☞ 2-8)*

- Install the new gaskets to the cylinder head covers.
- Apply SUZUKI BOND to the cam end caps of the gaskets as shown.

 **99104-31140: SUZUKI BOND “1207B” or equivalent**

**CAUTION**

**Use the new gaskets to prevent oil leakage.**

- Place the cylinder head covers on the cylinder heads.
- Fit a new gasket ① to each head cover bolts.

**CAUTION**

**Use a new gasket to prevent oil leakage.**

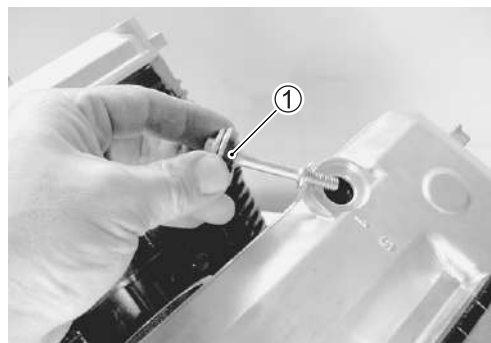
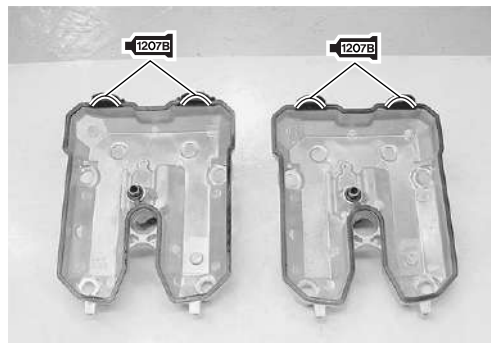
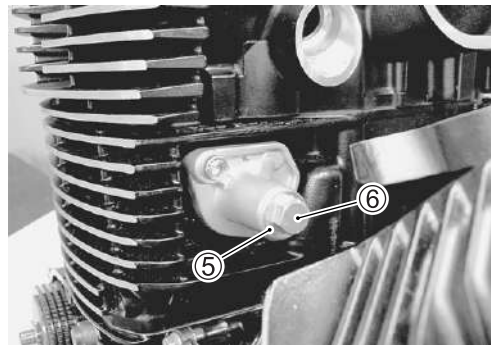

- Tighten the head cover bolts in ascending order of numbers to the specified torque.

**Head cover bolt (Front and Rear):**

**11 N·m (1.1 kgf-m, 8.0 lb-ft)**

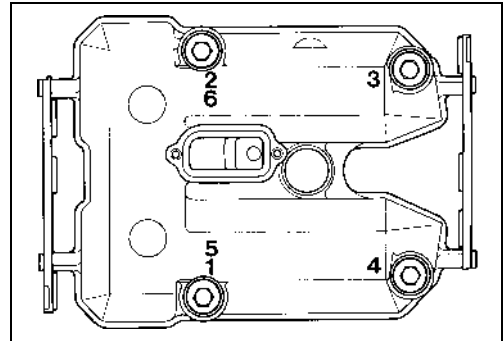
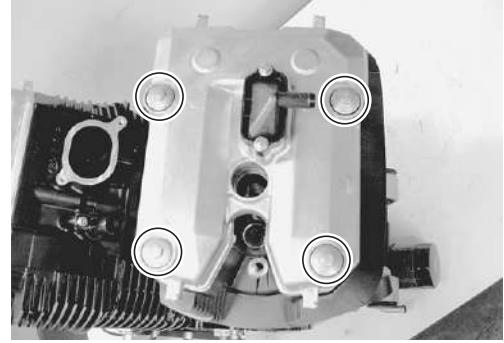

**GENERATOR COVER**

- Install the dowel pins and gasket ①.

**CAUTION**

**Use the new gasket to prevent oil leakage.**

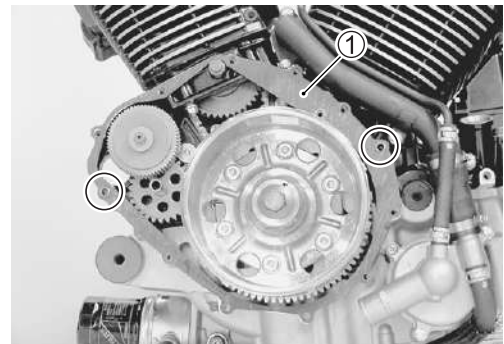

- Install the generator cover and tighten its bolts.

**NOTE:**

*Fit the new gasket washers to the bolts ①.*

**CAUTION**

**Use the new gasket to prevent oil leakage.**

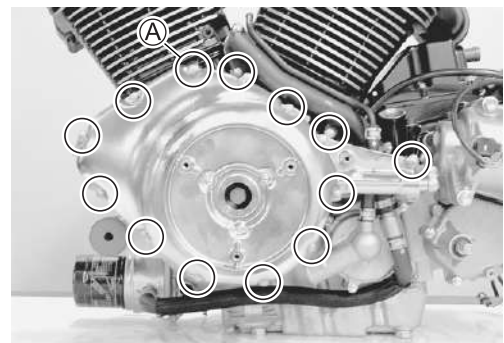

- Apply engine oil to the new O-ring and install the generator cover plug.

**CAUTION**

**Use the new O-ring to prevent oil leakage.**

- Tighten the generator cover plug ② and valve timing inspection plug ③ to the specified torque.

**Generator cover plug: 16 N·m (1.6 kgf-m, 11.5 lb-ft)**

**Valve timing inspection plug:**

**23 N·m (2.3 kgf-m, 16.5 lb-ft)**

- Install the generator cover cap ④.

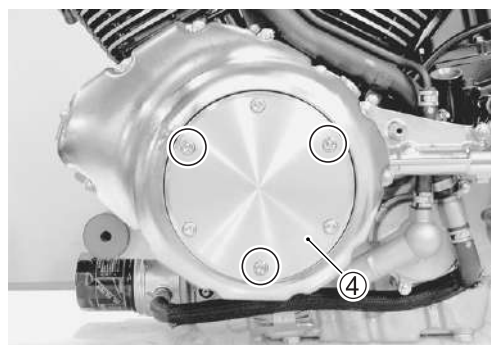
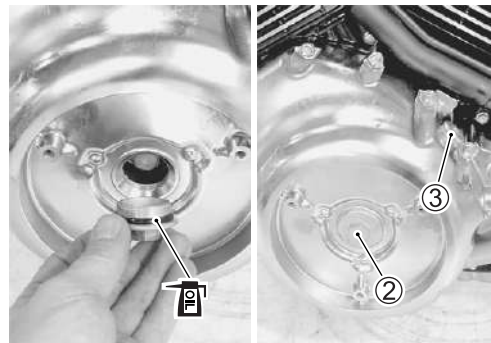
**CLUTCH COVER**

- Loosen the lock nut ① and turn in the release screw ② to feel resistance.
- From that position, turn out the release screw ② 1 turn and tighten the lock nut ① securely by holding the release screw ②.

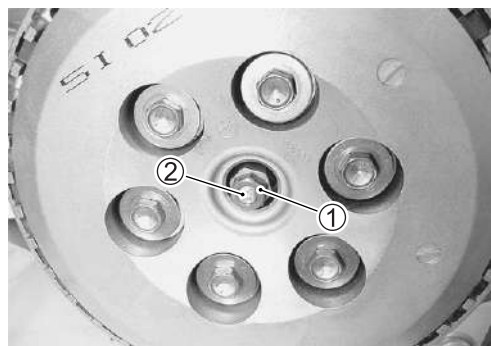

- Install the dowel pins and gasket ③.

**CAUTION**

**Use the new gasket to prevent oil leakage.**

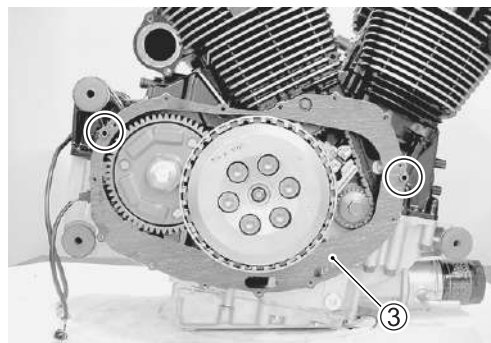



- Install the clutch cover and tighten its bolts.

**NOTE:**

Fit the new gasket washers to the bolts (A).

**CAUTION**

**Use a new gasket washer to prevent oil leakage.**

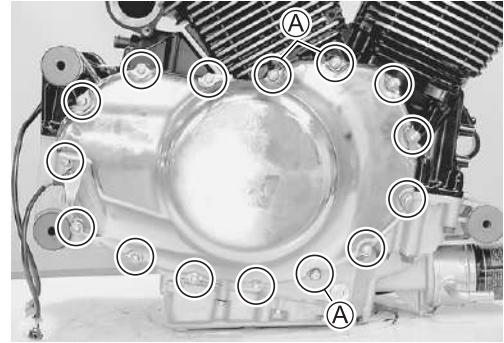

**THERMOSTAT**

- Apply engine coolant to the O-ring.

**CAUTION**

**Use a new O-ring to prevent engine coolant leakage.**

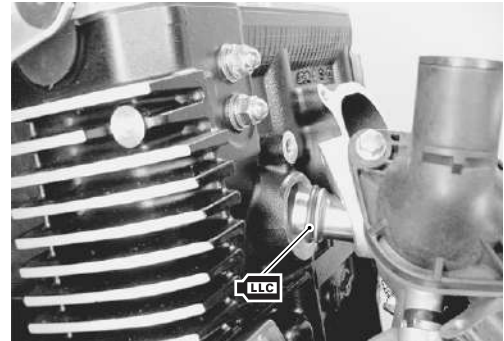

- Install the thermostat assembly ① and connect the water hoses ②.
- Tighten the thermostat assembly bolt.

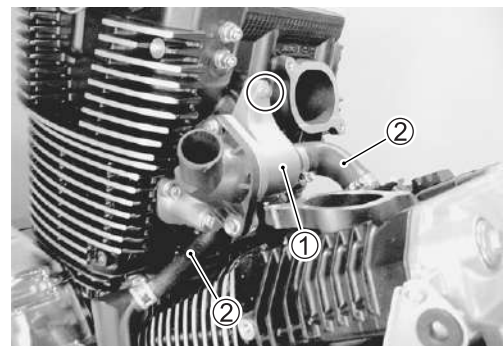

**INTAKE PIPE**

- Apply SUZUKI SUPER GREASE "A" to the O-ring.

 99000-25010: SUZUKI SUPER GREASE "A" or equivalent

- Install the intake pipes.

**CAUTION**

**Use the new O-ring to prevent air from scking through the joint.**

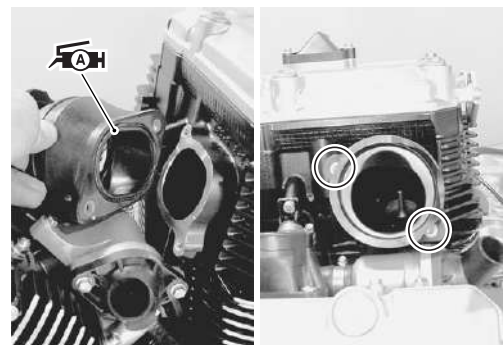

**NOTE:**

Face the "UP" mark on the intake pipe to the upper.



**STARTER MOTOR**

- Apply SUZUKI SUPER GREASE "A" to the O-ring.

 99000-25010: SUZUKI SUPER GREASE "A"  
or equivalent

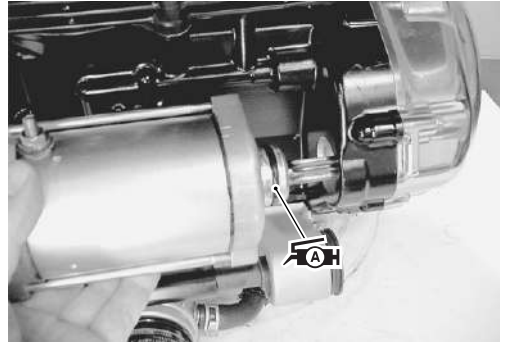

- Tighten the starter motor ① bolts to the specified torque.

 Starter motor bolt: 6 N·m (0.6 kgf-m, 4.5 lb-ft)

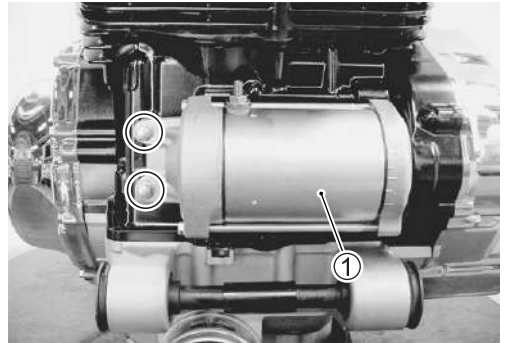

- Install the spark plugs. ( 2-16)

# DRIVELINE/AXLE

## CONTENTS

<b>SECONDARY BEVEL GEARS .....</b>	<b>4- 2</b>
<b>CONSTRUCTION .....</b>	<b>4- 2</b>
<b>REMOVAL .....</b>	<b>4- 4</b>
<b>DISASSEMBLY .....</b>	<b>4- 4</b>
<b>INSPECTION .....</b>	<b>4- 6</b>
<b>REASSEMBLY .....</b>	<b>4- 8</b>
<b>SECONDARY GEAR SHIMS ADJUSTMENT .....</b>	<b>4-10</b>
<b>FINAL BEVEL GEARS .....</b>	<b>4-13</b>
<b>CONSTRUCTION .....</b>	<b>4-13</b>
<b>FINAL GEAR CASE REMOVAL .....</b>	<b>4-15</b>
<b>FINAL GEAR CASE DISASSEMBLY .....</b>	<b>4-15</b>
<b>FINAL GEAR SHIMS ADJUSTMENT .....</b>	<b>4-20</b>
<b>FINAL GEAR CASE REASSEMBLY .....</b>	<b>4-24</b>
<b>FINAL GEAR CASE INSTALLATION .....</b>	<b>4-28</b>

## SECONDARY BEVEL GEARS CONSTRUCTION

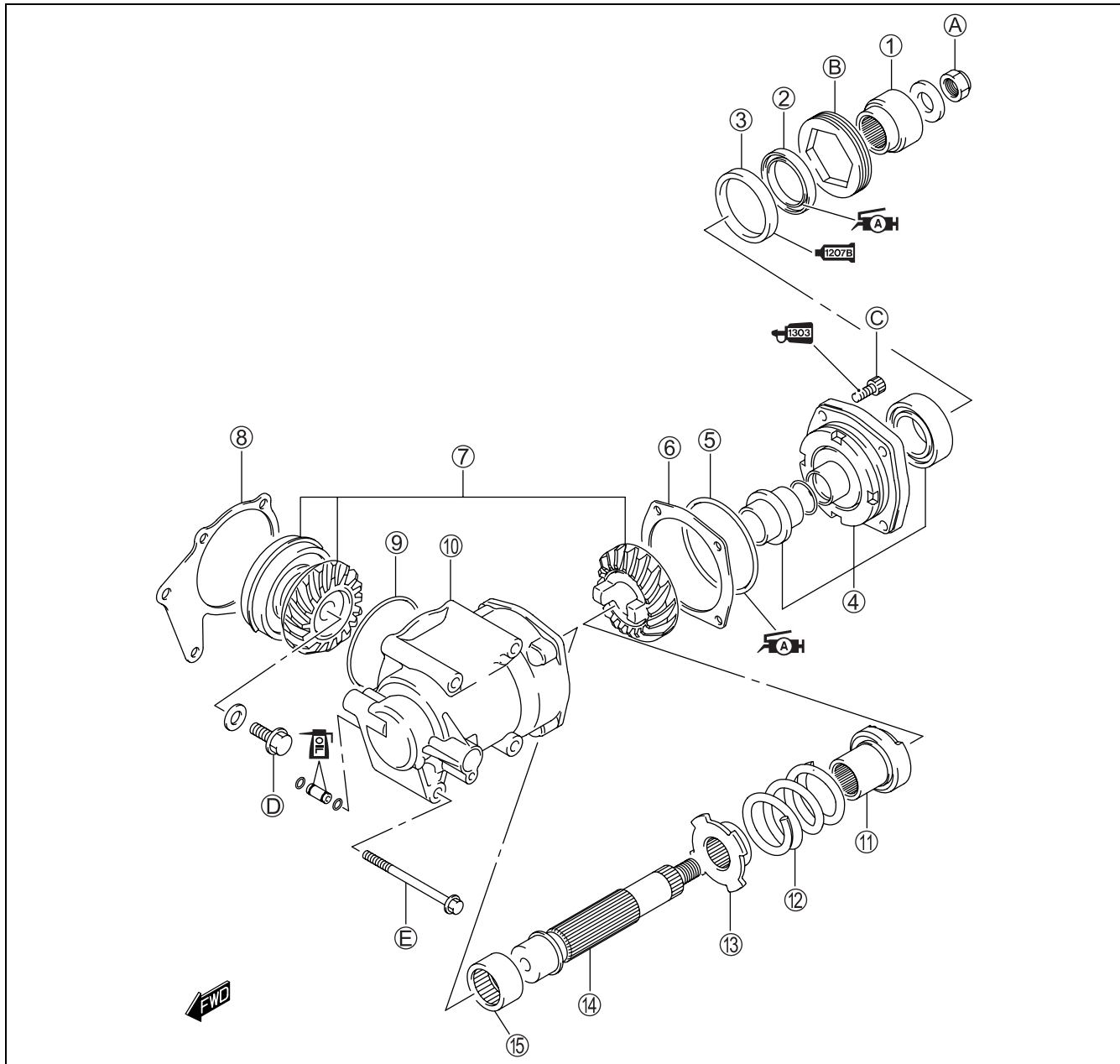

①	Driven bevel gear coupling	⑧	Shims	⑮	Driven bevel gear bearing
②	Oil seal	⑨	O-ring	Ⓐ	Driven bevel gear coupling nut
③	Oil seal housing	⑩	Secondary gear case	Ⓑ	Secondary driven bearing stopper
④	Bearing housing set	⑪	Output cam dog	Ⓒ	Secondary driven bearing housing bolt
⑤	O-ring	⑫	Damper spring	Ⓓ	Secondary drive gear bolt
⑥	Shims	⑬	Spring cam stopper	Ⓔ	Secondary driven gear case bolt
⑦	Secondary bevel gear set	⑭	Driven bevel gear shaft		



ITEM	N·m	kgf·m	lb·ft
Ⓐ	95	9.5	68.5
Ⓑ	105	10.5	76.0

ITEM	N·m	kgf·m	lb·ft
Ⓒ	28	2.8	20.0
Ⓓ	145	14.5	105.0

ITEM	N·m	kgf·m	lb·ft
Ⓔ	26	2.6	19.0

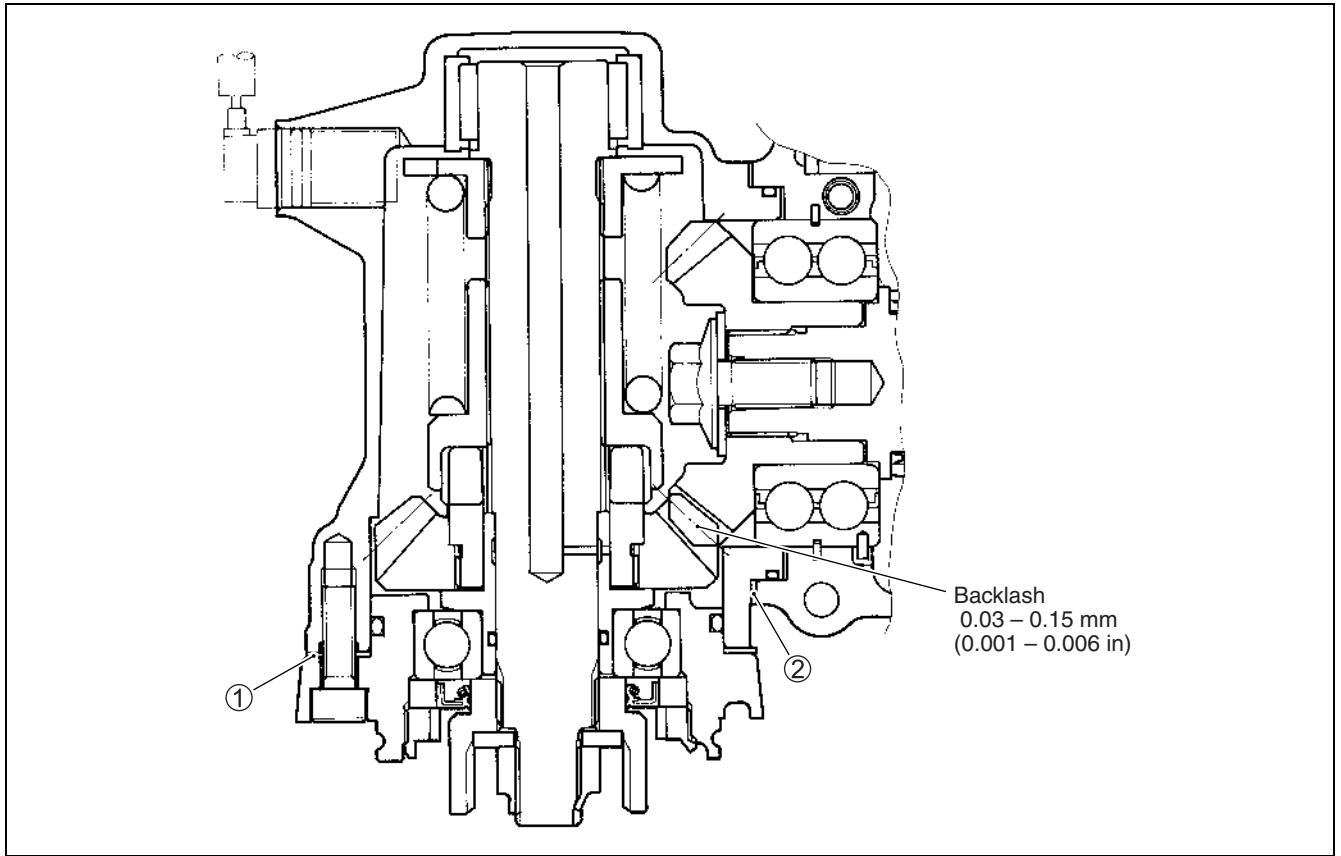

Adjust backlash by selecting shims. (Use two pieces of shims.)

Shim ① size table

Part number	Thickness
24945-26D00-030	0.30 mm (0.012 in)
24945-26D00-035	0.35 mm (0.014 in)
24945-26D00-040	0.40 mm (0.016 in)
24945-26D00-050	0.50 mm (0.020 in)
24945-26D00-060	0.60 mm (0.024 in)

The shims ① are available as a set (24945-26810).

Shim ② size table

Part number	Thickness
24935-48G00-040	0.40 mm (0.016 in)
24935-48G00-045	0.45 mm (0.018 in)
24935-48G00-050	0.50 mm (0.020 in)
24935-48G00-055	0.55 mm (0.022 in)
24935-48G00-060	0.60 mm (0.024 in)
24935-48G00-065	0.65 mm (0.026 in)
24935-48G00-070	0.70 mm (0.028 in)
24935-48G00-075	0.75 mm (0.030 in)
24935-48G00-080	0.80 mm (0.031 in)

The shims ② are available as a set (24935-48810).

## REMOVAL

The secondary bevel gear service requires engine removal and disassembly. Refer to the engine removal and the engine disassembly sections for secondary bevel gear assembly removal.

Engine removal  3-3

## DISASSEMBLY

### SECONDARY DRIVE BEVEL GEAR ( 3-28)

#### SECONDARY DRIVEN BEVEL GEAR

- Remove the secondary gear case ① and speedometer sensor ②.

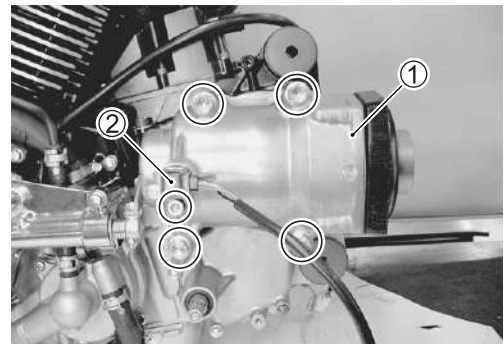

- Remove the shims ③.



- Remove the secondary driven gear assembly ④.

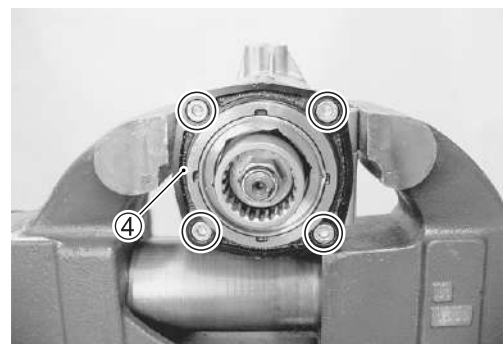

- Remove the shims ⑤.



- Using a chisel, unlock the nut.
- Remove the driven bevel gear coupling nut with the special tool.

 **09924-64510: Final drive gear coupling holder**



- Remove the washer ⑥ and the driven bevel gear coupling ⑦.

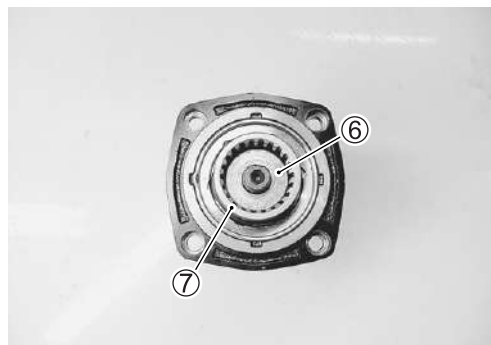

- Using a chisel, unlock the nut.



- Remove the bearing stopper with the special tool.

 **09924-41830: Bearing retainer wrench**





- Remove the bearing housing ⑧, secondary driven gear ⑨, output cam dog ⑩, damper spring ⑪, spring cam stopper ⑫ and shaft ⑬.

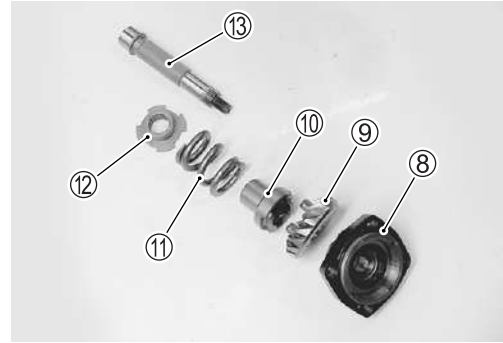

## INSPECTION

- \* Driven bevel gear damage or wear
- \* Improper tooth contact
- \* Output cam dog wear or damage
- \* Shaft damage or wear.
- \* Universal joint spline damage or wear



## BEARING/OIL SEAL

- Rotate the bearing inner race by finger to inspect for abnormal play, noise and smooth rotation while the bearings are in the bearing housing and secondary gear case.
- Replace the bearing in the following procedure if there is anything unusual.

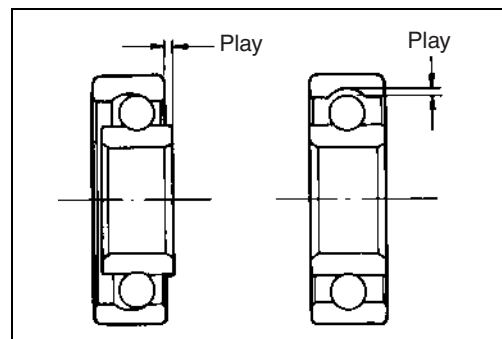

- Remove the oil seal with the special tool.

**TOOL** 09913-50121: Oil seal remover

**CAUTION**

The removed oil seal must be replaced with a new one.

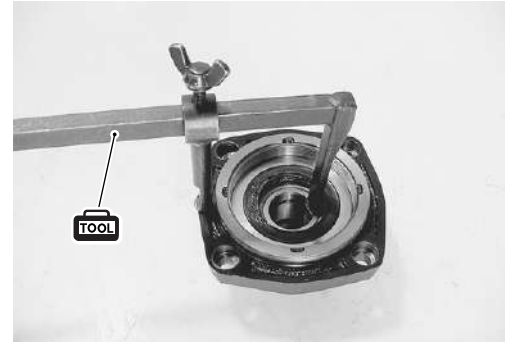

- Remove the driven gear stopper with the special tool.

**TOOL** 09913-70210: Bearing installer set (30 mm)



- Remove the bearings (①, ②) and oil seal housing ③ with the special tools.

**TOOL** 09921-20240: Bearing remover set (30 mm)

09941-64511: Bearing remover

09930-30104: Sliding shaft

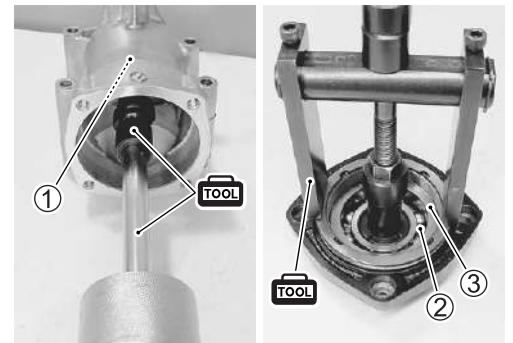

### DAMPER SPRING

Measure the free length of the damper spring. If the length is shorter than the service limit, replace the spring with a new one.

**DATA** Damper spring free length

Service limit: 64.6 mm (2.54 in)

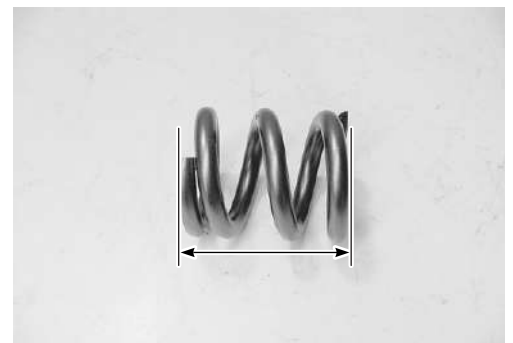

### SPEEDOMETER SENSOR (☞ 10-37)

## REASSEMBLY

- Reassemble the secondary driven gear in the reverse order of disassembly.
- The following steps require special attention or precautionary measures should be taken.

### BEARING AND OIL SEAL HOUSING

- Install the bearing with the special tool.

**TOOL** 09913-70210: Bearing installer set (68 mm)

#### NOTE:

When installing the bearing, stamped mark on the bearing must face outside.



- Install the bearing with the special tool.

**TOOL** 09913-70210: Bearing installer set (42 mm)

#### NOTE:

When installing the bearing, stamped mark on the bearing must face outside.



- Apply SUZUKI BOND to the mating surface of the bearing housing and oil seal housing.

**1207B** 99000-31140: SUZUKI BOND "1207B" or equivalent

#### NOTE:

\* Make surfaces free from moisture, oil, dust and other foreign materials.

\* Take extreme care not to apply any BOND to the bearing.

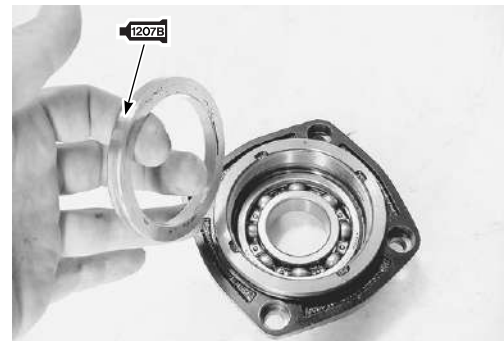

### DRIVEN GEAR STOPPER

- Install the driven gear stopper with the special tool.

**TOOL** 09913-70210: Bearing installer set (52 mm)

#### NOTE:

The chamfer side (A) of driven gear stopper faces to the bearing.

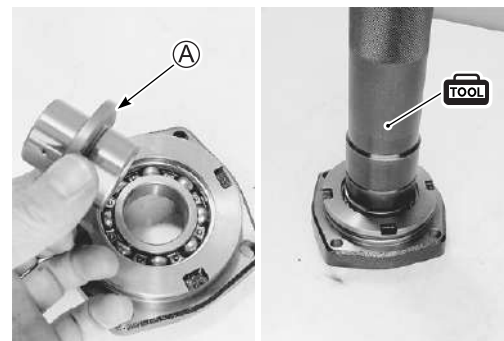

- Install the oil seal with the special tool.

 **09913-70210: Bearing installer set (62 mm)**

- Apply SUZUKI SUPER GREASE “A” to the oil seal lip.

 **99000-25010: SUZUKI SUPER GREASE “A”**  
or equivalent

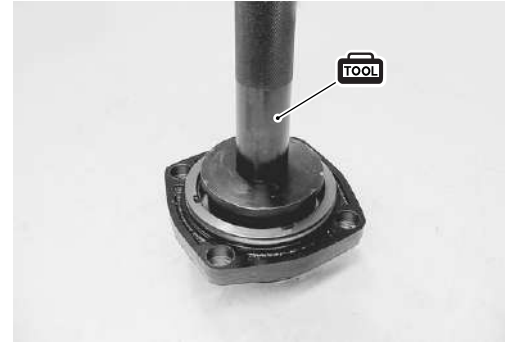

### SECONDARY DRIVEN BEVEL GEAR

- Install the secondary driven gear ①.

**NOTE:**

When install the secondary driven gear, fit the convex parts **A** of the secondary driven gear onto the concave parts **B** of the output cam dog.

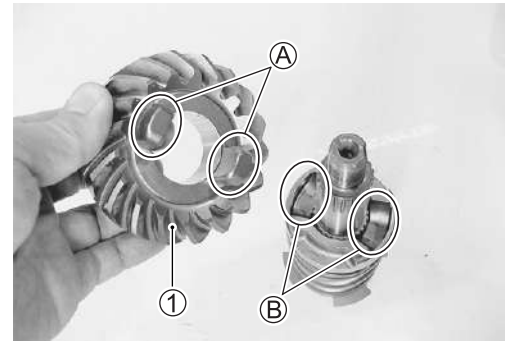

- Tighten the bearing stopper to the specified torque with special tool.

 **Secondary driven gear bearing stopper:**  
**105 N·m (10.5 kgf-m, 76.0 lb-ft)**

 **09924-41830: Bearing retainer wrench**

- Lock the bearing stopper with a center punch.

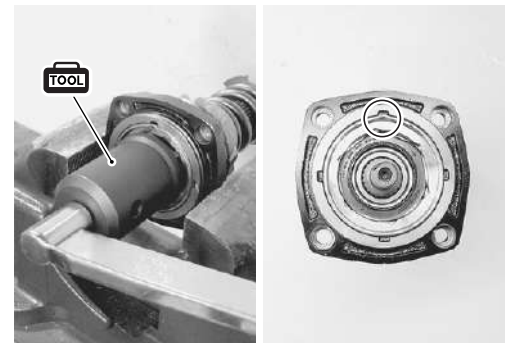

- Tighten the coupling nut to the specified torque with the special tool.

 **Secondary driven bevel gear coupling nut:**  
**95 N·m (9.5 kgf-m, 68.5 lb-ft)**

 **09924-64510: Final drive coupling holder**

- Lock the coupling nut with a center punch.



- Install the shims ②. (🔧 4-12)
- Apply SUZUKI SUPER GREASE “A” to the O-ring.

 **99000-25010: SUZUKI SUPER GREASE “A”**  
or equivalent

**CAUTION**

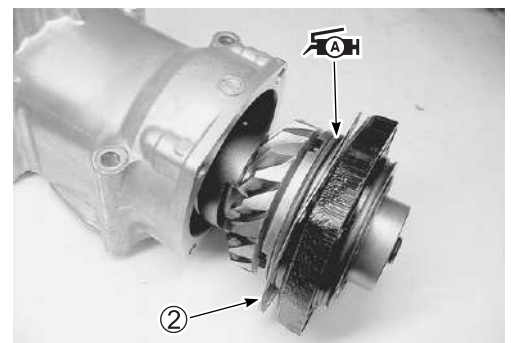

Use a new O-ring to prevent to oil leakage.



- Install the secondary driven gear assembly ③.
- Apply a small quantity of the THREAD LOCK SUPER to the bearing housing bolts and tighten it to the specified torque.

 **99000-32030: THREAD LOCK SUPER “1303” or equivalent**

 **Secondary driven bearing housing bolt:**  
**28 N·m (2.8 kgf·m, 20.0 lb·ft)**

- Install the shims ④. ( 4-12)
- Install the secondary gear case. ( 3-90)
- Install the speedometer sensor. ( 10-37)

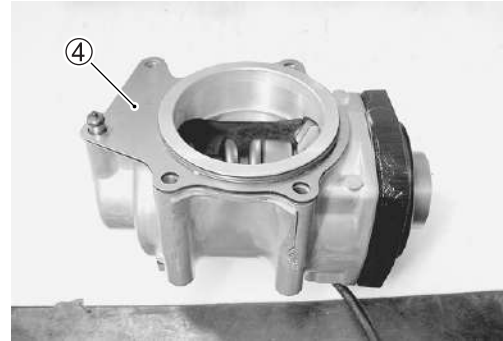
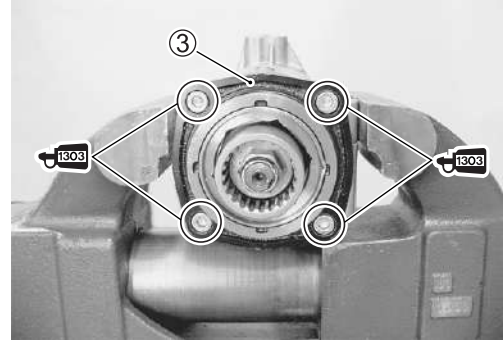

## SECONDARY GEAR SHIMS ADJUSTMENT BACKLASH

- Install the secondary driven gear assembly and secondary gear case with removed shims. ( 3-79 and 4-9)

### NOTE:

*Do not install the O-ring on the driven gear housing at this stage. O-ring is installed after backlash and tooth contact are correct.*

- Tighten the secondary driven gear case bolts to the specified torque.

 **Secondary driven gear case bolt:**  
**26 N·m (2.6 kgf·m, 19.0 lb·ft)**

- Measure the backlash as follows.
- Install the backlash measuring tool on the driven bevel gear coupling, and set-up a dial gauge as shown in photo.

 **09924-34510: Backlash measuring tool (27 – 50 mm)**  
**09900-20607: Dial gauge (1/100 mm, 10 mm)**  
**09900-20701: Magnetic stand**

- Adjust the dial gauge so that it touches the backlash measuring tool arm at the mark; hold the secondary drive bevel gear securely, and turn the secondary driven bevel gear coupling slightly in each direction, reading the total backlash on the dial gauge.

 **Secondary bevel gear backlash**  
**Standard: 0.03 – 0.15 mm (0.001 – 0.006 in)**

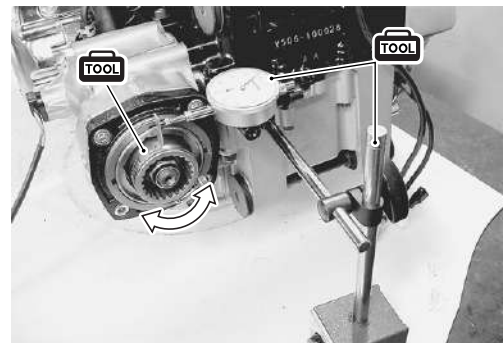
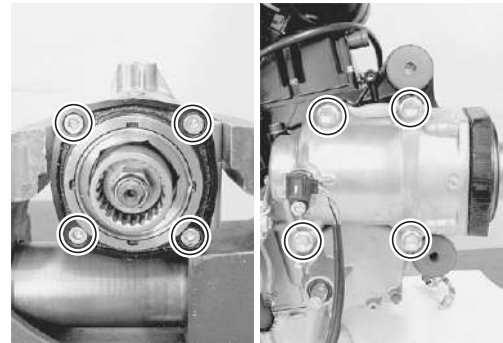

- If the backlash is not within specification, the shims (Driven bevel gear side) must be changed and the backlash should be re-checked until correct.

Refer to the chart for appropriate changes.

**NOTE:**

When changing the shims (Driven bevel gear side), measure the thickness of old shims. Using the thickness of the old shims as a guide, adjust the backlash by referring to the chart.

Backlash	Shim adjustment
Under 0.03 mm (0.001 in)	Increase shim thickness
0.03 – 0.15 mm (0.001 – 0.006 in)	Correct
Over 0.15 mm (0.006 in)	Decrease shim thickness

Driven bevel gear side

Part number	Shim thickness
24945-26D00-030	0.30 mm (0.012 in)
24945-26D00-035	0.35 mm (0.014 in)
24945-26D00-040	0.40 mm (0.016 in)
24945-26D00-050	0.50 mm (0.020 in)
24945-26D00-060	0.60 mm (0.024 in)

**NOTE:**

The shims (driven bevel gear side) are available as a set (24945-26810).



**TOOTH CONTACT**

After bringing the backlash within specification by changing the secondary driven bevel gear shims, it will be necessary to check tooth contact.

- Remove the secondary gear case. (☞ 4-4)
- Clean and degrease the secondary drive bevel gear teeth, and apply a coating of machinist's layout dye or paste to several teeth.

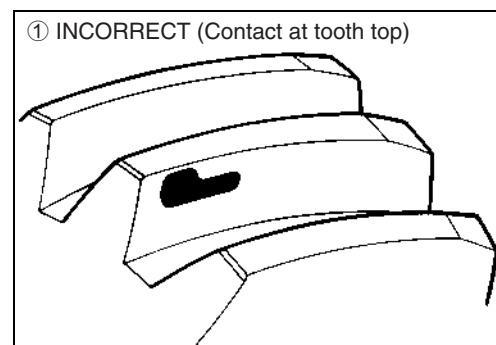

- Reinstall the secondary gear case, with removed shims.
- Rotate the secondary driven bevel gear coupling several turns in both directions.
- Remove the secondary gear case from the crankcase, and observe the tooth contact pattern made in the dye or paste.
- Compare the tooth contact pattern to the examples as shown in ①, ② and ③.

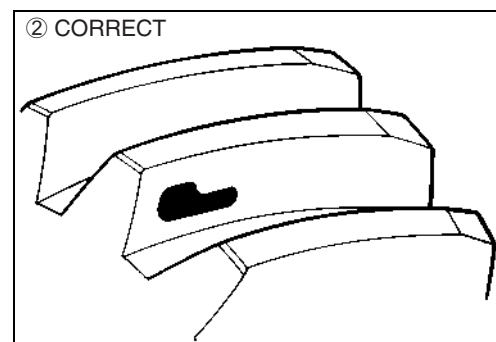



- If tooth contact is found to be incorrect, the shims of the secondary drive bevel gear and secondary driven bevel gear must be changed, tooth contact should be re-checked until correct.

**CAUTION**

After the tooth contact adjustment is made, the backlash must be re-checked, as it may change. Refer to the backlash checking sub-section, and readjust until both backlash and tooth contact are correct.

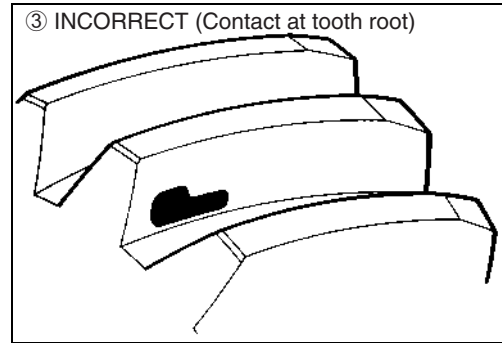

Tooth contact	Shim adjustment
Contact at tooth top ①	Decrease thickness of shims ④ or ⑤
Contact at tooth root ③	Increase thickness of shims ④ or ⑤

**SHIM SPECIFICATIONS**

Drive bevel gear side

Part number	Thickness
24935-48G00-040	0.40 mm (0.016 in)
24935-48G00-045	0.45 mm (0.018 in)
24935-48G00-050	0.50 mm (0.020 in)
24935-48G00-055	0.55 mm (0.022 in)
24935-48G00-060	0.60 mm (0.024 in)
24935-48G00-065	0.65 mm (0.026 in)
24935-48G00-070	0.70 mm (0.028 in)
24935-48G00-075	0.75 mm (0.030 in)
24935-48G00-080	0.80 mm (0.031 in)

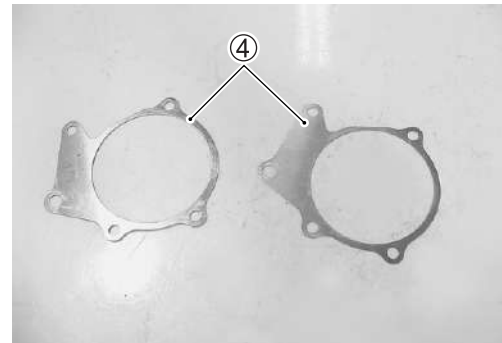

**NOTE:**

The shims (drive bevel gear side) are available as a set (24935-48810).

Driven bevel gear side

Part number	Shim thickness
24945-26D00-030	0.30 mm (0.012 in)
24945-26D00-035	0.35 mm (0.014 in)
24945-26D00-040	0.40 mm (0.016 in)
24945-26D00-050	0.50 mm (0.020 in)
24945-26D00-060	0.60 mm (0.024 in)

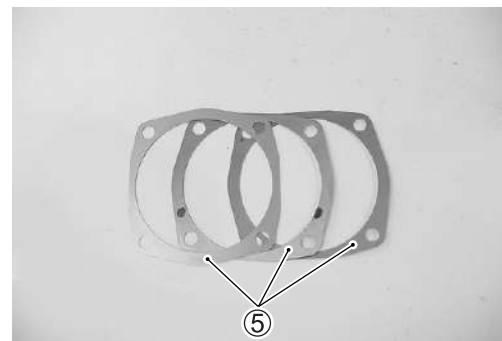

**NOTE:**

The shims (driven bevel gear side) are available as a set (24945-26810).

# FINAL BEVEL GEARS CONSTRUCTION

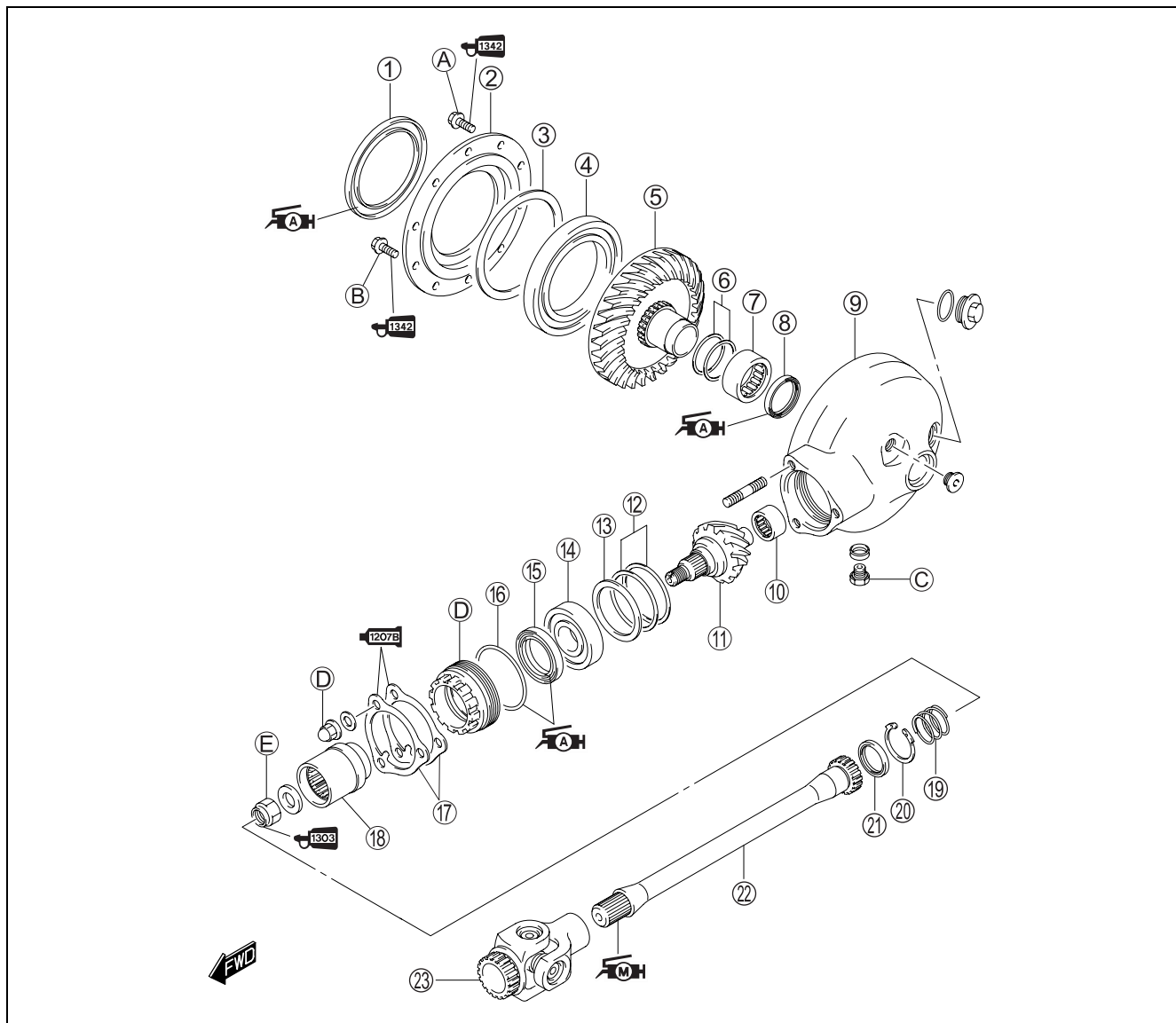

①	Oil seal	⑪	Final drive bavel gear	⑳	Oil seal
②	Final gear bearing case	⑫	Shims	㉒	Propeller shaft
③	Shims	⑬	Washer	㉓	Universal joint
④	Final driven gear bearing	⑭	Final drive bevel gear bearing	(A)	Final gear case bolt (M8)
⑤	Final driven bevel gear	⑮	Oil seal	(B)	Final gear case bolt (M10)
⑥	Shims	⑯	O-ring	(C)	Oil drain plug
⑦	Final driven gear bearing	⑰	Stopper plate	(D)	Final gear case nut
⑧	Oil seal	⑱	Final drive gear coupling	(E)	Final driven gear coupling nut
⑨	Final gear case	⑲	Spring		
⑩	Final drive gear bearing	㉑	Snap ring		



ITEM	N-m	kgf-m	lb-ft
(A)	23	2.3	16.5
(B)	50	5.0	36.0
(C)	23	2.3	16.5

ITEM	N-m	kgf-m	lb-ft
(D)	40	4.0	29.0
(E)	100	10.0	72.5

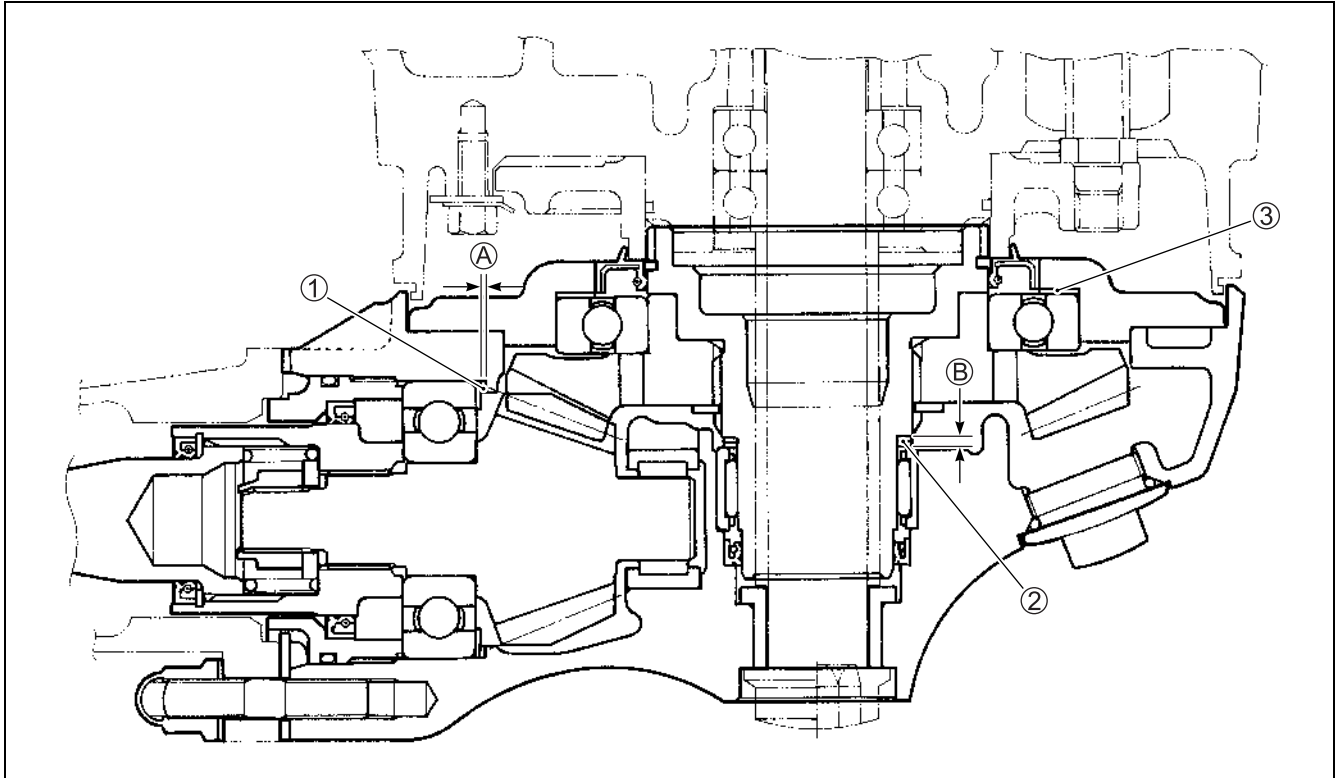

Standard clearance **A**: 1.00 mm (0.039 in)

**Shim ① size table**

Part number	Thickness
27445-24A01-030	0.30 mm (0.012 in)
27445-24A01-035	0.35 mm (0.014 in)
27445-24A01-040	0.40 mm (0.016 in)
27445-24A01-050	0.50 mm (0.020 in)
27445-24A01-060	0.60 mm (0.024 in)

The shims ① are available as a set (27445-24810).

Standard clearance **B**: 2.8 mm (0.110 in)

**Shim ② size table**

Part number	Shim thickness
09181-40011	0.95 mm (0.026 in)
09181-40013	1.05 mm (0.041 in)
09181-40014	1.10 mm (0.043 in)
09181-40176	1.20 mm (0.047 in)
09181-40182	1.40 mm (0.055 in)
09181-40212	1.50 mm (0.059 in)
27326-48G00-125	1.25 mm (0.049 in)
27326-48G00-135	1.35 mm (0.053 in)
27326-48G00-145	1.45 mm (0.057 in)

The shims ② are available as a set (27326-48810).

Shim ③ – Gear case cover clearance:  
0.1 mm (0.004 in)

**Shim ③ size table**

Part number	Thickness
27327-38B00-035	0.35 mm (0.014 in)
27327-38B00-040	0.40 mm (0.016 in)
27327-38B00-050	0.50 mm (0.020 in)
27327-38B00-060	0.60 mm (0.024 in)

The shims ③ are available as a set (27327-38810).

## FINAL GEAR CASE REMOVAL

After draining final gear oil, the following components must be removed in the described order before removing the final gear case.

- Drain final gear oil. (☞ 2-19)
- Remove the rear wheel. (☞ 9-34)
- Remove the final gear case nut, spring washer and final gear case ①.

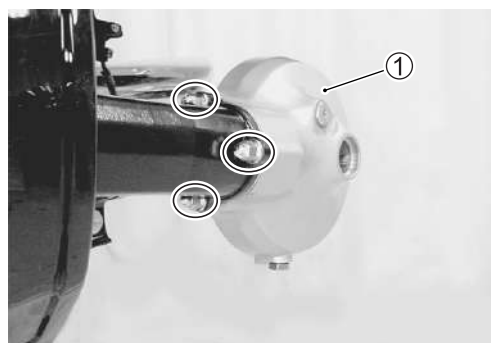

## FINAL GEAR CASE DISASSEMBLY

- Remove the plate ①.

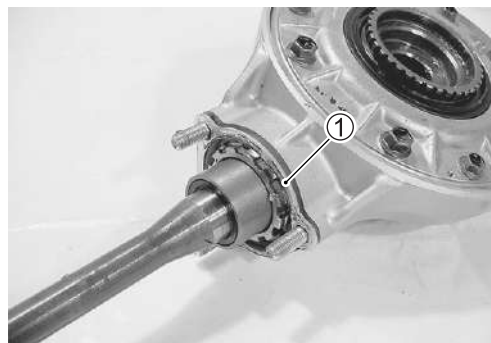

- Remove the dust seal ②.

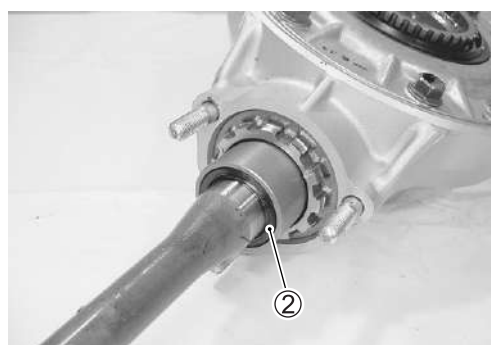

- Remove the snap ring ③.

 **09900-06108: Snap ring pliers**

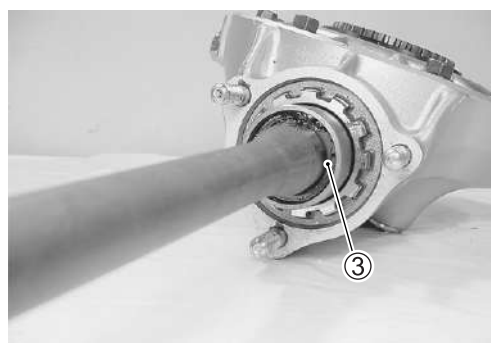

- Remove the propeller shaft ④ and spring ⑤.

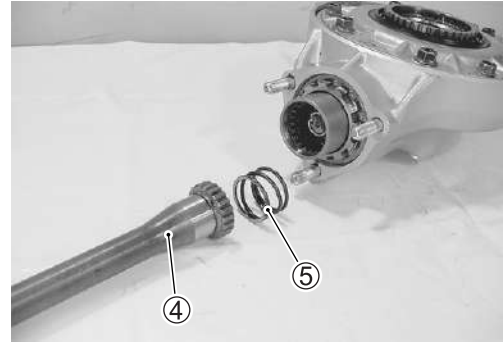

- Using a chisel, unlock the nut.
- Remove the final drive gear coupling nut with the special tool.

**TOOL** 09924-62430: 22 mm Long socket  
09924-64510: Final drive gear coupling holder

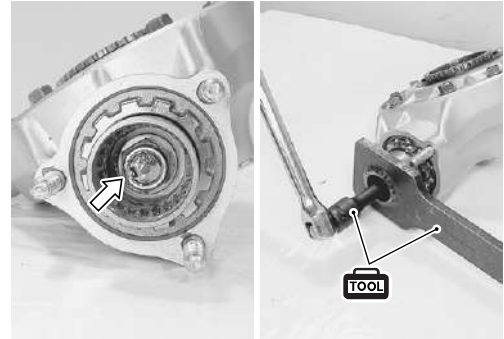

- Remove the washer ⑥ and the final drive gear coupling ⑦.

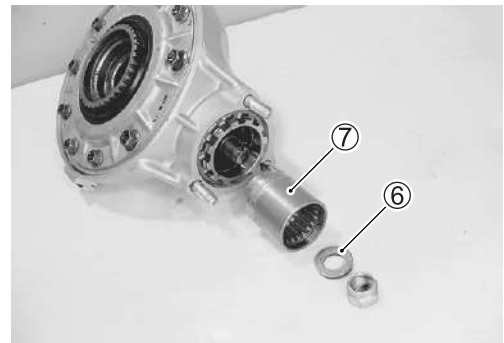

- Remove the bearing stopper with the special tool.

**TOOL** 09924-62410: Final drive gear bearing holder wrench



- Remove the final drive bevel gear with bearing ⑧ and shims ⑨.

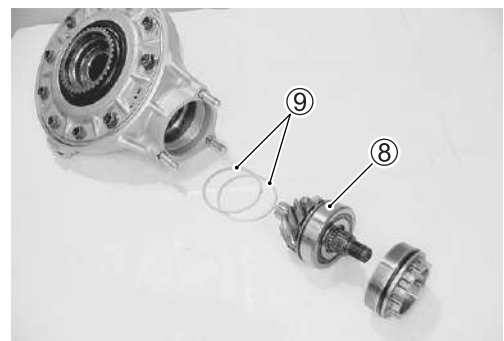

- Remove the bearing with the inner race from the final drive bevel gear with the special tool.

 **09913-60910: Bearing puller**

**CAUTION**

**The removed bearing must be replaced with a new one.**

**NOTE:**

*If no abnormal noise, the bearing removal is not necessary.*

- Remove the washer ⑩.
- Remove the inner race with the special tool.

 **09913-60910: Bearing puller**

**CAUTION**

**When replacing the drive bevel gear, replace the driven bevel gear also, as they must be replaced together.**

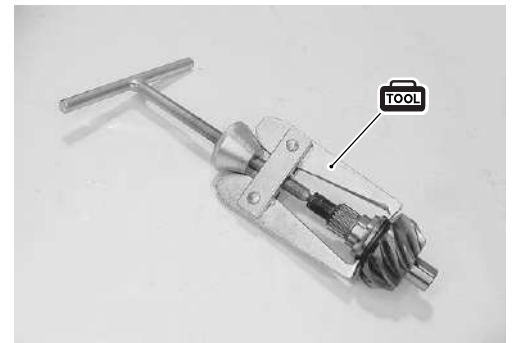
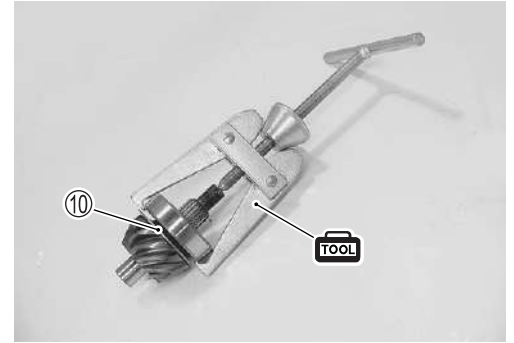

- Remove the final gear bearing case bolts.



- Remove the final gear bearing case from the final gear case, by using two 5 mm screws.





- Remove the shim ⑪ and final driven bevel gear ⑫.



- Remove the shims ⑬.

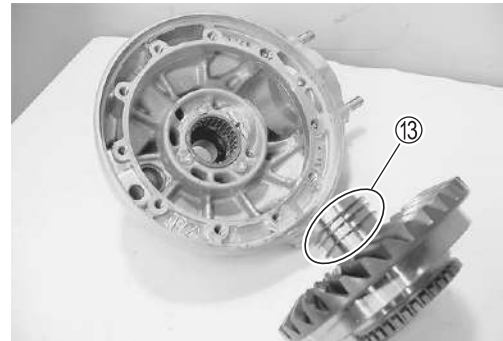

- Using two bolts or suitable bars, remove the final driven bevel gear bearing from the bevel gear.

**NOTE:**

*If no abnormal noise the bearing removal is not necessary.*

**CAUTION**

**The removed bearing must be replaced with a new one.**



- Remove the oil seal with the special tool.

**TOOL** 09913-50121: Oil seal remover

**CAUTION**

**The removed oil seal must be replaced with a new one.**

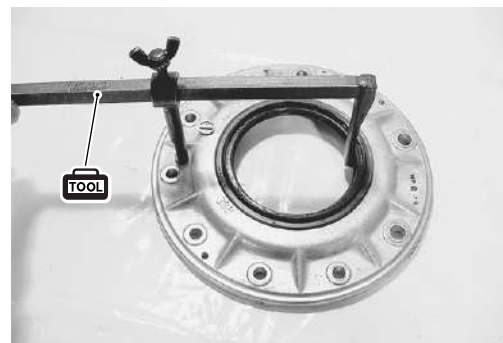

- Remove the final driven gear bearing ⑭ and oil seal ⑮ with the special tools.

**TOOL** 09941-64511: Bearing remover  
09930-30104: Sliding shaft

#### CAUTION

The removed bearing and oil seal must be replaced with new ones.

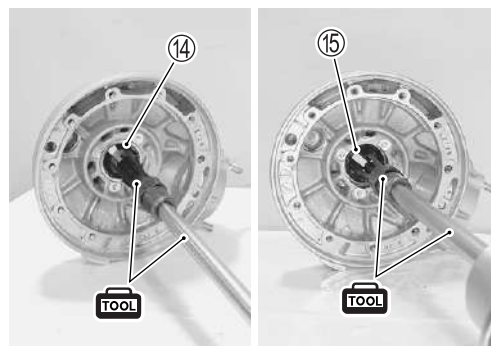

- Remove the final drive gear bearing with the special tools.

**TOOL** 09923-74511: Bearing remover  
09930-30104: Sliding shaft

#### CAUTION

The removed bearing must be replaced with a new one.



#### NOTE:

If no abnormal noise, the bearing removal is not necessary.

- Remove the oil seal ⑯ and O-ring ⑰ from the bearing stopper.

#### CAUTION

The removed oil seal and O-ring must be replaced with new ones.



#### INSPECTION

Inspect the removed parts for the following abnormalities.

- \* Drive and driven bevel gear damage or wear
- \* Improper tooth contact
- \* Abnormal noise of bearings
- \* Bearing damage or wear
- \* Oil seal damage or wear
- \* Propeller shaft spline damage or wear
- \* Spring for damage or fatigue



## FINAL GEAR SHIMS ADJUSTMENT

### FINAL GEAR BEARING CASE SHIM CLEARANCE

- Install the final driven gear, shims (① and ②) and final gear bearing case to the final gear case.

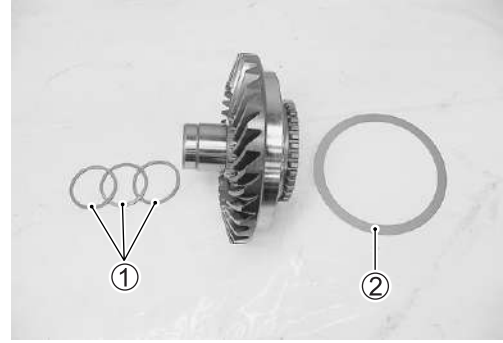

- Tighten the final gear case bolts to the specified torque.

**Final gear case bolt (M8): 23 N·m (2.3 kgf-m, 16.5 lb-ft)**  
**(M10): 50 N·m (5.0 kgf-m, 36.0 lb-ft)**

#### NOTE:

*It is not necessary to apply SUZUKI BOND "1207B" and THREAD LOCK to the matching surface and bolts at this stage.*

- Measure the clearance between the shims and bearing. If it is not within the specification, the shims must be changed.



#### Standard

**DATA** Final gear case shim clearance

**Standard: 0.1 mm (0.04 in)**

#### Shims ② specifications

Part number	Shim thickness
27327-38B00-035	0.35 mm (0.014 in)
27327-38B00-040	0.40 mm (0.016 in)
27327-38B00-050	0.50 mm (0.020 in)
27327-38B00-060	0.60 mm (0.024 in)

#### NOTE:

*The shims ② are available as a set (27327-38810).*

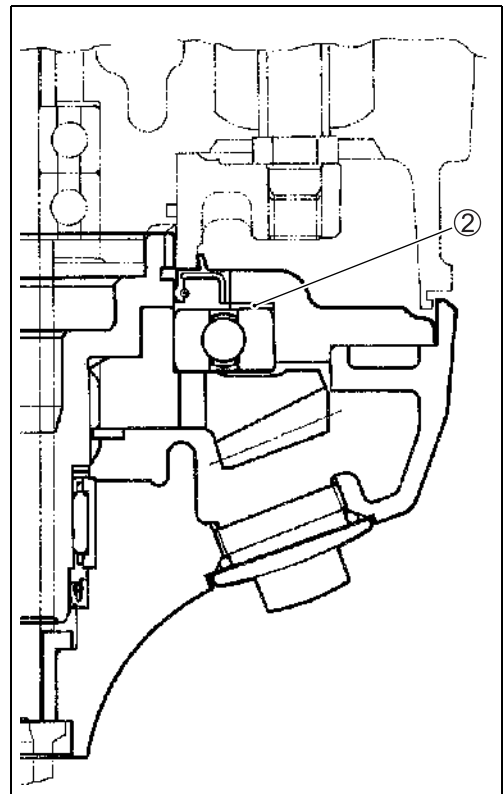

## BACKLASH

After assembling the final gear case (☞ 4-24), measure the final bevel gear backlash as follows.

- Install the backlash measuring tool on the drive bevel gear coupling, and set-up a dial gauge as shown in photo.

**TOOL** 09924-34510: Backlash measuring tool (27 – 50 mm)  
 09900-20607: Dial gauge (1/100 mm, 10 mm)  
 09900-20701: Magnetic stand

- Adjust the dial gauge so that it touches the backlash measuring tool arm at the mark; hold the final driven bevel gear securely, and turn the final drive bevel gear coupling slightly in each direction, reading the total backlash on the dial gauge.

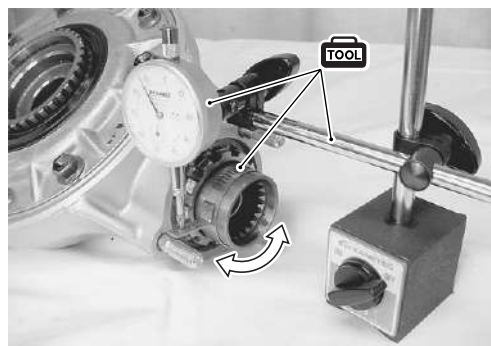

### **DATA** Final bevel gear backlash

**Standard: 0.08 – 0.16 mm (0.003 – 0.006 in)**

If the backlash is not within the specification, adjust the shim thickness as follows:

- Remove shims from final gear bearing case and final gear case, and measure total thickness.
- In order not to change the clearance between final driven bevel gear and bearing, the total thickness of the shims installed after a change is made must equal the original total thickness of shims.
- If backlash is too large:
  - a) Install a thinner shim pack ① between final driven bevel gear and final gear case.
  - b) Increase thickness of shims ② between final driven bevel gear bearing and bearing case by an amount equal to decrease above.
- If backlash is too small:
  - a) Install a thicker shim pack ① between final driven bevel gear and final gear case.
  - b) Decrease thickness of shims ② between final driven gear bearing and bearing case by an amount equal to increase above.

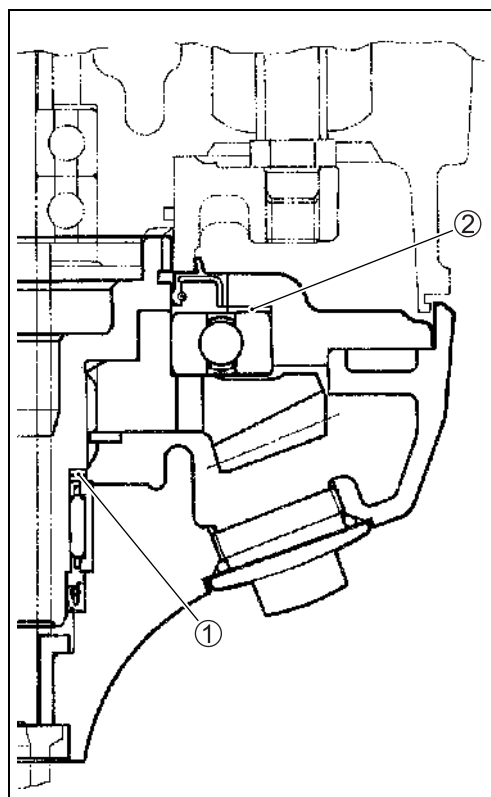

### Shims ① specifications

Part number	Shim thickness
09181-40011	0.95 mm (0.026 in)
09181-40013	1.05 mm (0.041 in)
09181-40014	1.10 mm (0.043 in)
09181-40176	1.20 mm (0.047 in)
09181-40182	1.40 mm (0.055 in)
09181-40212	1.50 mm (0.059 in)
27326-48G00-125	1.25 mm (0.049 in)
27326-48G00-135	1.35 mm (0.053 in)
27326-48G00-145	1.45 mm (0.057 in)

The shims ① are available as a set (27326-48810).

**Shims ② specifications**

Part number	Shim thickness
27327-38B00-035	0.35 mm (0.014 in)
27327-38B00-040	0.40 mm (0.016 in)
27327-38B00-050	0.50 mm (0.020 in)
27327-38B00-060	0.60 mm (0.024 in)

The shims ② are available as a set (27327-38810).

**EXAMPLE:**

Final gear to case shims ①;  $1.45 \text{ mm} + 1.40 \text{ mm} = 2.85 \text{ mm}$

Final gear bearing to bearing case shims ②,

$$0.35 \text{ mm} + 0.60 \text{ mm} = 0.95 \text{ mm}$$

$$\text{Original total measurement} = 3.80 \text{ mm}$$

**Backlash too large:**

Final gear to case shims ①;  $1.35 \text{ mm} + 1.45 \text{ mm} = 2.80 \text{ mm}$

Final gear bearing to bearing case shims ②,

$$0.60 \text{ mm} + 0.40 \text{ mm} = 1.00 \text{ mm}$$

$$\text{Total thickness} = 3.80 \text{ mm}$$

**Backlash too small:**

Final gear to case shims ①;  $1.50 \text{ mm} + 1.40 \text{ mm} = 2.90 \text{ mm}$

Final gear bearing to bearing case shims ②;

$$0.50 \text{ mm} + 0.40 \text{ mm} = 0.90 \text{ mm}$$

$$\text{Total thickness} = 3.80 \text{ mm}$$

**TOOTH CONTACT**

After backlash adjustment is carried out, the tooth contact must be checked.

- Remove the bolts from the final gear bearing case, and remove the case with the two 5 mm screws. (→ 4-17)  
Do not misplace the shims. Remove the final driven bevel gear.
- Clean and de-grease several teeth on the final driven bevel gear. Coat these teeth with machinist's dye or paste, preferably of a light color.
- Re-install the final driven bevel gear with shims in place, positioning the coated teeth so that they are centered on the final drive bevel gear.
- Re-install the final gear bearing case and bolts, and tighten to specification.

**Final gear case bolt (M8): 23 N·m (2.3 kgf-m, 16.5 lb-ft)**  
**(M10): 50 N·m (5.0 kgf-m, 36.0 lb-ft)**

- Using a socket and handle on the final drive bevel gear coupling nut, rotate the final drive bevel gear several turns in each direction, while loading the final driven bevel gear. This will provide a contact pattern on the coated teeth of the driven bevel gear.

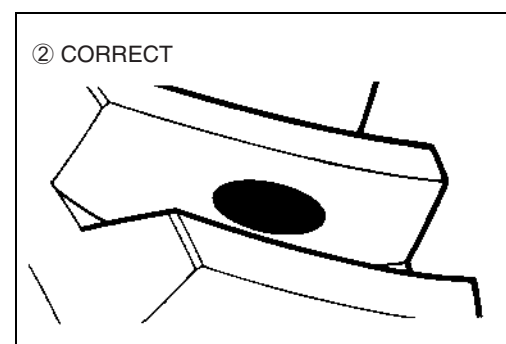
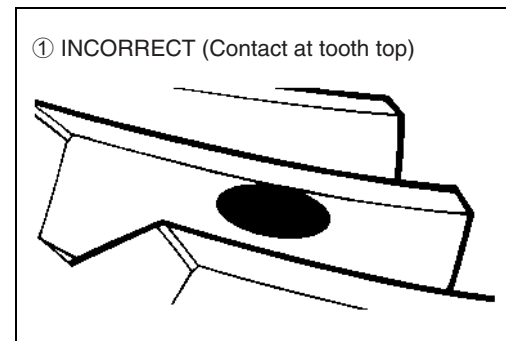

- Remove the final gear bearing case and final driven bevel gear, and inspect the coated teeth of the driven bevel gear. The contact patch should be as shown at right:
- If the tooth contact pattern is incorrect, as shown in ①, a thinner shim ④ is needed between the final drive bevel gear bearing and final gear case.
- If the tooth contact pattern is incorrect, as shown in ③, a thicker shim ④ is needed between the final drive bevel gear bearing and final gear case.
- If the tooth contact pattern is incorrect for either reason, the appropriate shim must be installed, and the tooth contact pattern rechecked by repeating the tooth coating procedure above.

**NOTE:**

*If it is necessary to adjust the shim ④ thickness between final drive bevel gear bearing and final gear case, the final gear backlash may change, and should be re-checked according to the procedure outlined under the Backlash Measurement sub-section. Both adjustments may be needed until both backlash and tooth contact are correct.*

**Shims ④ specification**

Part No.	Shim thickness
27445-24A01-030	0.30 mm (0.012 in)
27445-24A01-035	0.35 mm (0.014 in)
27445-24A01-040	0.40 mm (0.016 in)
27445-24A01-050	0.50 mm (0.020 in)
27445-24A01-060	0.60 mm (0.024 in)

**The shims ④ are available as a set (27445-24810).**

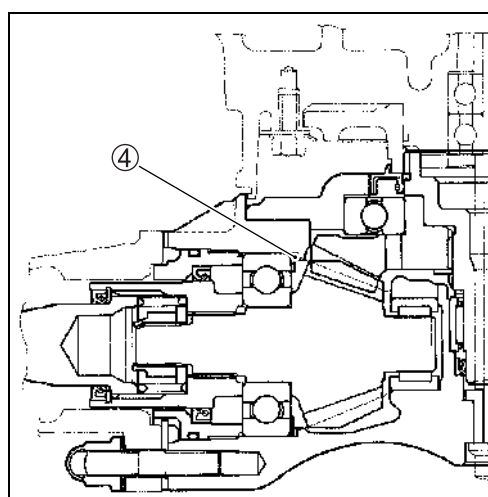
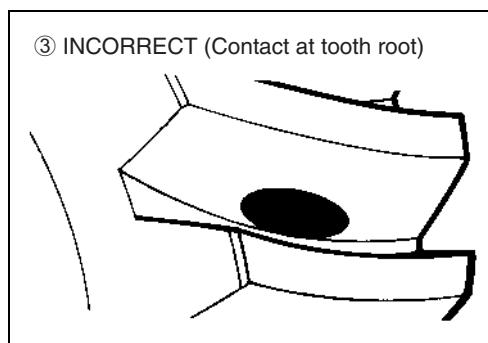



## FINAL GEAR CASE REASSEMBLY

Reassemble the final gear case in the reverse order of disassembly. Pay attention to the following points.

- Install a new oil seal ① and O-ring ② to the bearing stopper.



- Install the final drive gear bearing into the final gear case with the special tool.

 **09913-75821 : Bearing installer**



- Install the oil seal into the final gear case with the special tool.

 **09913-76010: Bearing installer set**

### CAUTION

- \* Use a new oil seal to prevent oil leakage.
- \* The lip and spring of the oil seal (A) should face to the driven bevel gear side.

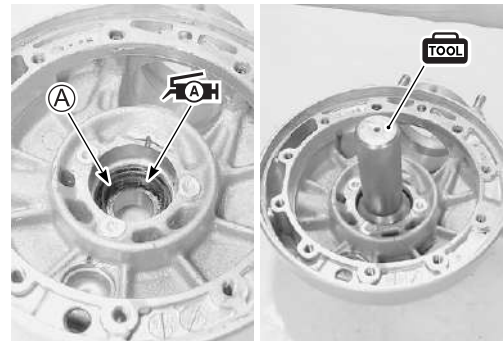

- Apply SUZUKI SUPER GREASE "A" to the oil seal lip.

 **99000-25010: SUZUKI SUPER GREASE "A"**  
or equivalent

- Install the final driven gear bearing into the final gear case with the special tool.

 **09951-16080: Bearing installer**

### NOTE:

The stamped mark side of bearing face to the driven bevel gear side.



- Install a new oil seal to the final gear bearing case with the special tool.

**TOOL 09951-16310: Final gear case oil seal installer**

- Apply SUZUKI SUPER GREASE “A” to the lip of the oil seal.

**AH 99000-25010: SUZUKI SUPER GREASE “A” or equivalent**

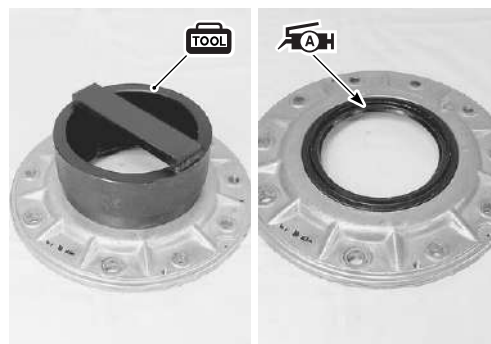

- Install the final driven bevel gear bearing to the bevel gear with the special tool.

**TOOL 09951-17010: Final driven gear bearing installer**



- Install correct shims (③, ④) to the both sides of the final driven bevel gear and install the gear to the final gear case.

Shim adjustment (4-20)

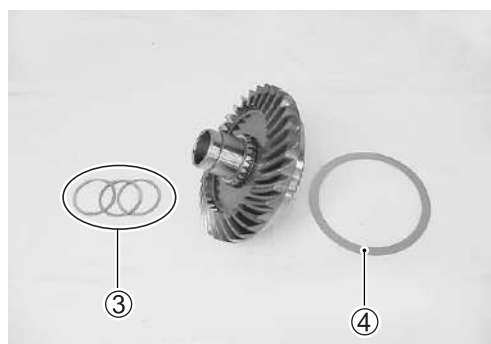

- Apply SUZUKI BOND to the mating surface of the final gear case and final gear bearing case.

**CAUTION**

**Do not block the breather passage when applying SUZUKI BOND.**

**1207B 99000-31140: SUZUKI BOND “1207B” or equivalent**



- Apply THREAD LOCK to the final gear case bolts and tighten them to the specified torque.

**1342 99000-32050: THREAD LOCK “1342” or equivalent**

**Final gear case bolt (M8): 23 N·m (2.3 kgf-m, 16.5 lb-ft)  
(M10): 50 N·m (5.0 kgf-m, 36.0 lb-ft)**

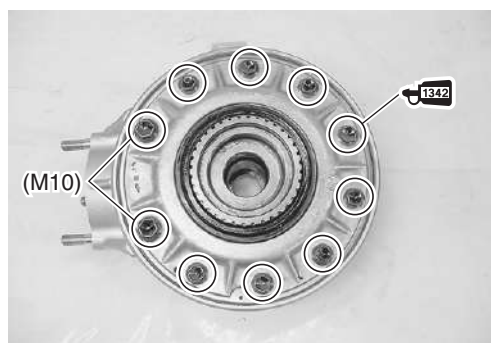

- Install the inner race ⑤, washer ⑥, bearing ⑦ and inner race ⑧, with the special tool.

**TOOL** 09913-84510: Bearing installer

**NOTE:**

When installing the bearing, stamped mark on the bearing must face outside.

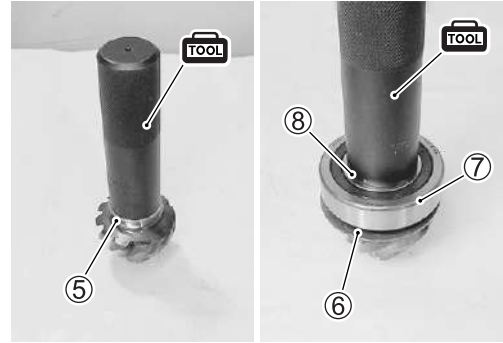

- Install the correct shims ⑨ to the final drive bevel gear and install the bevel gear to the final gear case.

Shim adjustment (☞ 4-23)



- Apply SUZUKI SUPER GREASE “A” to the O-ring and the lip of oil seal.
- Install the bearing stopper ⑩.

**CAUTION**

Use a new oil seal and O-ring to prevent oil leakage.

**AH** 99000-25010: SUZUKI SUPER GREASE “A”  
or equivalent

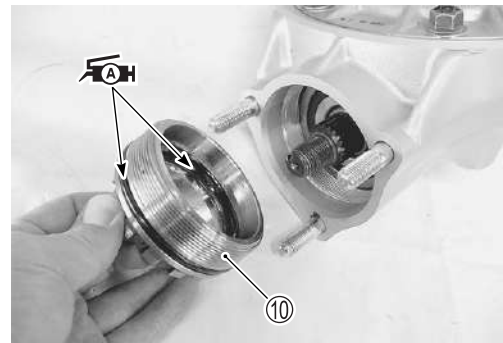

- Tighten the bearing stopper to the specified torque with the special tool.

**TOOL** 09924-62410: Final drive gear bearing holder wrench

**Final drive bevel gear bearing stopper:**  
110 N·m (11.0 kgf·m, 79.5 lb-ft)



- Install the final drive gear coupling ⑪ and washer ⑫.
- Apply a small quantity of the THREAD LOCK SUPER to the final drive gear coupling nut.

**1303** 99000-32030: THREAD LOCK SUPER “1303”  
or equivalent

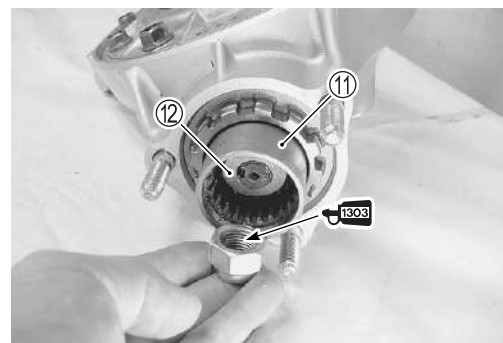

- Tighten the nut to the specified torque with the special tool.

 **Final drive gear coupling nut:**

**100 N·m (10.0 kgf-m, 72.5 lb-ft)**

 **09924-62430: 22 mm Long socket**

**09924-64510: Final drive gear coupling holder**

- Lock the final drive bevel gear coupling nut with a center punch.

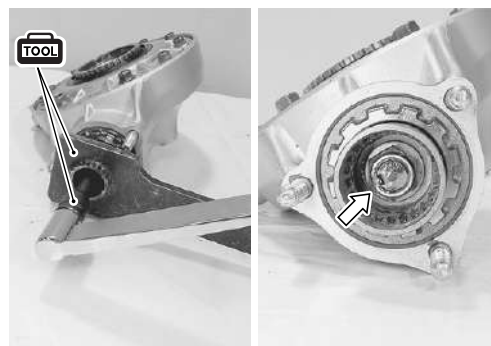

- Apply 5 – 7 cm<sup>3</sup> Lithium Base Molybdenum grease (NLGI#2) to the propeller shaft splines and final drive bevel gear coupling.
- Install the spring (13) and propeller shaft (14).

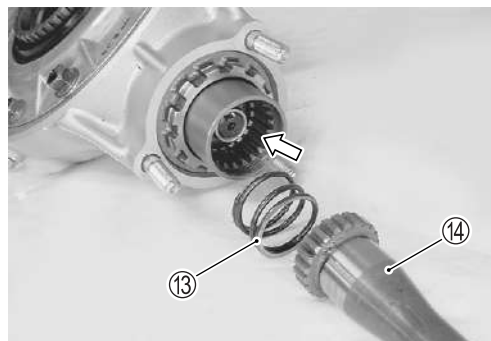

- Install the snap ring (15).
- After installing the propeller shaft with a new snap ring, make sure that the propeller shaft turns smoothly without any hitch or bearing noise.

 **09900-06108: Snap ring pliers**



- Install the dust seal with the special tool.

 **09940-51410: Steering bearing installer**

**09925-18011: Bearing installer**

- Apply SUZUKI SUPER GREASE “A” to the lip of the dust seal.

**CAUTION**

**Use a new dust seal to prevent oil leakage.**

 **99000-25010: SUZUKI SUPER GREASE “A”**

**or equivalent**

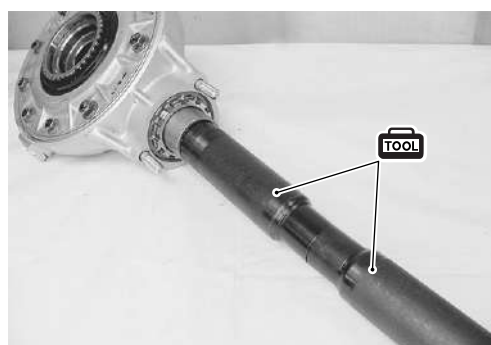

- Apply SUZUKI BOND to the mating surface of final gear case.
- ▶ **1207B** 99000-31140: SUZUKI BOND “1207B” or equivalent
- Install the stopper plate ⑯ to the final gear case.

**CAUTION**

When installing the plate, fit the protrusion **B** of plate to the one of the bearing stopper grooves.

**NOTE:**

Two kinds of plates are available to lock the stopper at the proper position.

- Apply SUZUKI BOND to the mating surface of swingarm.
- ▶ **1207B** 99000-31140: SUZUKI BOND “1207B” or equivalent

- Apply Lithium Base Molybdenum grease (NLGI#2) to the propeller shaft spline.

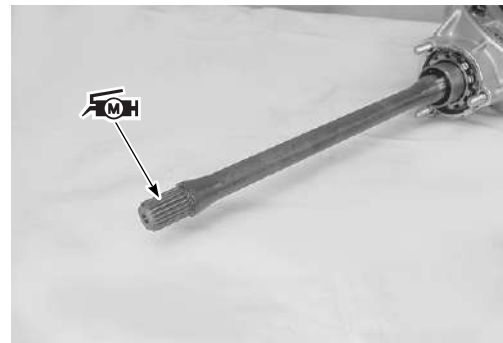
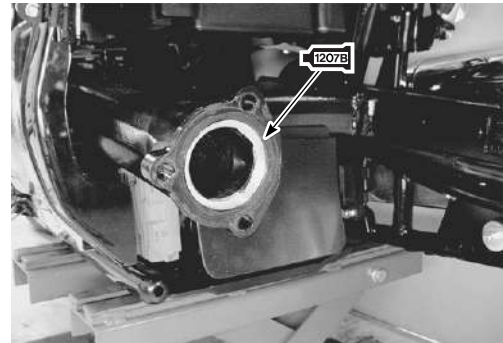
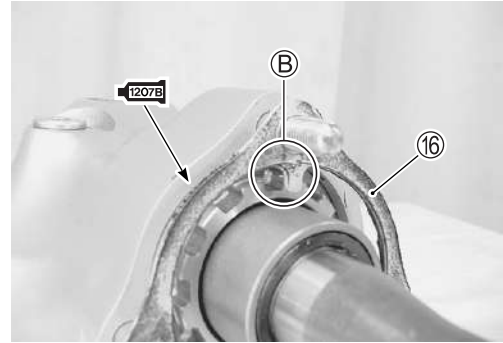

**FINAL GEAR CASE INSTALLATION**

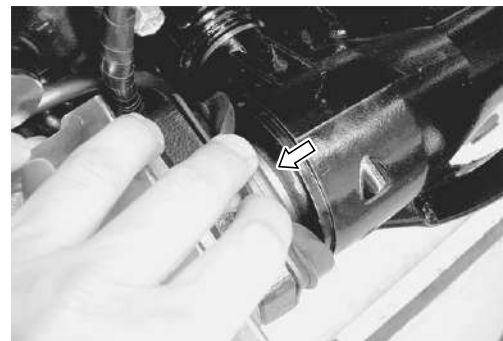

**NOTE:**

To install the final gear case easily, move the dust boot front and the universal joint turn into the propeller shaft.



- Install the final gear case.
- Tighten the final gear case bolts to the specified torque.

 **Final gear case nut: 40 N-m (4.0 kgf-m, 29.0 lb-ft)**

- Install the rear wheel. ( 9-39)
- Pour final gear oil. ( 2-19)

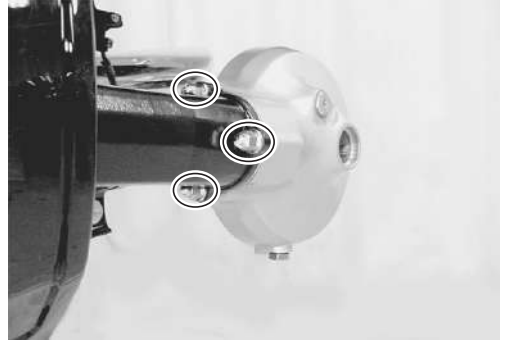



# FI SYSTEM DIAGNOSIS

## CONTENTS

<b>PRECAUTIONS IN SERVICING</b> .....	5- 3
<b>ELECTRICAL PARTS</b> .....	5- 3
<b>FUSE</b> .....	5- 4
<b>ECM/VARIOUS SENSORS</b> .....	5- 4
<b>ELECTRICAL CIRCUIT INSPECTION PROCEDURE</b> .....	5- 6
<b>USING THE MULTI-CIRCUIT TESTER</b> .....	5- 9
<b>FI SYSTEM TECHNICAL FEATURES</b> .....	5-10
<b>INJECTION TIME (INJECTION VOLUME)</b> .....	5-10
<b>COMPENSATION OF INJECTION TIME (VOLUME)</b> .....	5-11
<b>INJECTION STOP CONTROL</b> .....	5-11
<b>FI SYSTEM PARTS LOCATION</b> .....	5-12
<b>FI SYSTEM WIRING DIAGRAM</b> .....	5-14
<b>ECM TERMINAL</b> .....	5-15
<b>SELF-DIAGNOSIS FUNCTION</b> .....	5-17
<b>USER MODE</b> .....	5-17
<b>DEALER MODE</b> .....	5-18
<b>TPS ADJUSTMENT</b> .....	5-20
<b>FAIL-SAFE FUNCTION</b> .....	5-21
<b>FI SYSTEM TROUBLESHOOTING</b> .....	5-22
<b>CUSTOMER COMPLAINT ANALYSIS</b> .....	5-22
<b>VISUAL INSPECTION</b> .....	5-23
<b>SELF-DIAGNOSTIC PROCEDURES</b> .....	5-24
<b>SELF-DIAGNOSIS RESET PROCEDURE</b> .....	5-24
<b>USE OF SDS DIAGNOSTIC PROCEDURES</b> .....	5-25
<b>USE OF SDS DIAGNOSIS RESET PROCEDURE</b> .....	5-26
<b>SHOW DATA WHEN TROUBLE</b>	
<b>(DISPLAING DATA AT THE TIME OF DTC)</b> .....	5-27
<b>MALFUNCTION CODE AND DEFECTIVE CONDITION</b> .....	5-28
<b>“C12” (P0335) CKP SENSOR CIRCUIT MALFUNCTION</b> .....	5-32
<b>“C13” (P1750-H/L) or “C17” (P0105-H/L) IAP SENSOR</b>	
<b>CIRCUIT MALFUNCTION</b> .....	5-34
<b>“C14” (P0120-H/L) TP SENSOR CIRCUIT MALFUNCTION</b> .....	5-41
<b>“C15” (P0115-H/L) ECT SENSOR CIRCUIT MALFUNCTION</b> .....	5-46
<b>“C21” (P0110-H/L) IAT SENSOR CIRCUIT MALFUNCTION</b> .....	5-50
<b>“C23” (P1651-H/L) TO SENSOR CIRCUIT MALFUNCTION</b> .....	5-54
<b>“C24” (P0351), “C25” (P0352), “C26” (P0353) or</b>	
<b>“C27” (P0354) IGNITION SYSTEM MALFUNCTION</b> .....	5-57
<b>“C28” (P1655) STV ACTUATOR CIRCUIT MALFUNCTION</b> .....	5-58
<b>“C29” (P1654-H/L) STP SENSOR CIRCUIT MALFUNCTION</b> .....	5-61
<b>“C31” (P0705) GP SWITCH CIRCUIT MALFUNCTION</b> .....	5-66

# FI SYSTEM DIAGNOSIS

## CONTENTS

<b>“C32” (P0201) or “C33” (P0202) FUEL INJECTOR CIRCUIT MALFUNCTION.....</b>	<b>5-68</b>
<b>“C40” (P0505-H/L or P0506 and P0507) ISC VALVE CIRCUIT MALFUNCTION.....</b>	<b>5-70</b>
<b>“C41” (P0230-H/L) FP RELAY CIRCUIT MALFUNCTION .....</b>	<b>5-76</b>
<b>“C42” (P01650) IG SWITCH CIRCUIT MALFUNCTION .....</b>	<b>5-78</b>
<b>“C44” (P0156/P0161) or “C64” (P0130/P0135) HO2 SENSOR (HO2S) CIRCUIT MALFUNCTION (FOR E-02, 19, 24) .....</b>	<b>5-79</b>
<b>“C46” (P1657-H/L or P1658) EXCV ACTUATOR CIRCUIT MALFUNCTION.....</b>	<b>5-83</b>
<b>“C49” (P1768) or “C61” (P1656) PAIR CONTROL SOLENOID VALVE CIRCUIT MALFUNCTION .....</b>	<b>5-92</b>
<b>“C60” (P0480) COOLING FAN RELAY CIRCUIT MALFUNCTION.....</b>	<b>5-94</b>
<b>SENSORS .....</b>	<b>5-97</b>
<b>IAP SENSOR INSPECTION .....</b>	<b>5-97</b>
<b>IAP SENSOR REMOVAL AND INSTALLATION.....</b>	<b>5-97</b>
<b>TP SENSOR INSPECTION .....</b>	<b>5-97</b>
<b>TP SENSOR REMOVAL AND INSTALLATION .....</b>	<b>5-97</b>
<b>TPS ADJUSTMENT.....</b>	<b>5-97</b>
<b>STP SENSOR INSPECTION .....</b>	<b>5-98</b>
<b>STP SENSOR REMOVAL AND INSTALLATION.....</b>	<b>5-98</b>
<b>STP SENSOR ADJUSTMENT .....</b>	<b>5-98</b>
<b>CKP SENSOR INSPECTION .....</b>	<b>5-98</b>
<b>CKP SENSOR REMOVAL AND INSTALLATION .....</b>	<b>5-98</b>
<b>IAT SENSOR INSPECTION .....</b>	<b>5-99</b>
<b>IAT SENSOR REMOVAL AND INSTALLATION.....</b>	<b>5-99</b>
<b>ECT SENSOR INSPECTION.....</b>	<b>5-99</b>
<b>ECT SENSOR REMOVAL AND INSTALLATION.....</b>	<b>5-99</b>
<b>TO SENSOR INSPECTION.....</b>	<b>5-99</b>
<b>TO SENSOR REMOVAL AND INSTALLATION.....</b>	<b>5-99</b>
<b>HO2 SENSOR INSPECTION (FOR E-02, 19, 24).....</b>	<b>5-100</b>
<b>HO2 SENSOR REMOVAL AND INSTALLATION (FOR E-02, 19, 24).....</b>	<b>5-100</b>

## PRECAUTIONS IN SERVICING

When handling the component parts or servicing the FI system, observe the following points for the safety of the system.

### ELECTRICAL PARTS

#### CONNECTOR/COUPLER

- When connecting a connector, be sure to push it in until a click is felt.

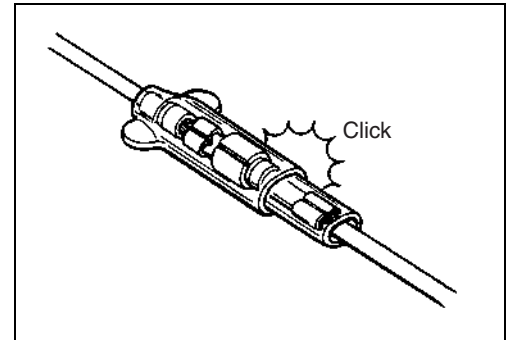

- With a lock type coupler, be sure to release the lock when disconnecting, and push in fully to engage the lock when connecting.
- When disconnecting the coupler, be sure to hold the coupler body and do not pull the lead wires.
- Inspect each terminal on the connector/coupler for looseness or bending.
- Inspect each terminal for corrosion and contamination. The terminals must be clean and free of any foreign material which could impede proper terminal contact.

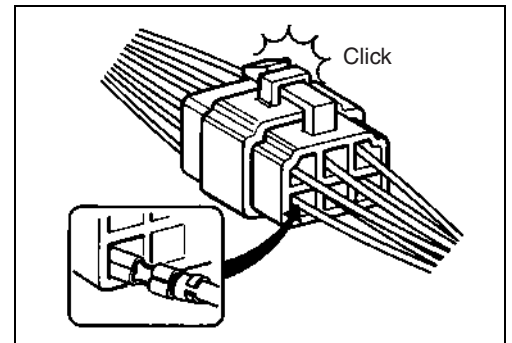

- Inspect each lead wire circuit for poor connection by shaking it by hand lightly. If any abnormal condition is found, repair or replace.

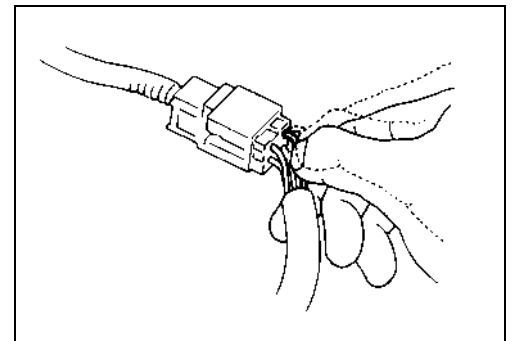

- When taking measurements at electrical connectors using a tester probe, be sure to insert the probe from the wire harness side (backside) of the connector/coupler.

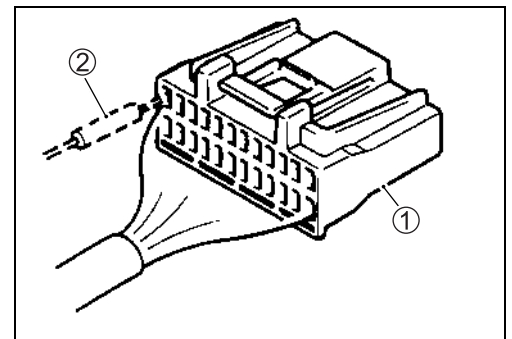

- ① Coupler
- ② Probe

- When connecting meter probe from the terminal side of the coupler (where connection from harness side not being possible), use extra care not to force and cause the male terminal to bend or the female terminal to open.

Connect the probe as shown to avoid opening of female terminal.

Never push in the probe where male terminal is supposed to fit.

- Check the male connector for bend and female connector for excessive opening. Also check the coupler for locking (looseness), corrosion, dust, etc.

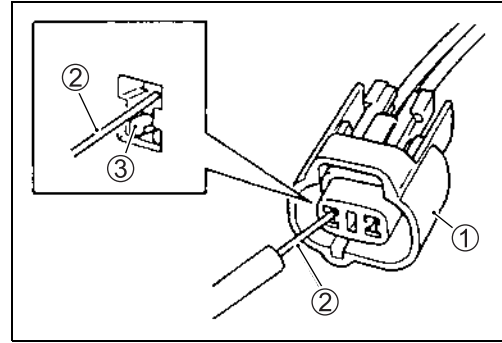

- ① Coupler
- ② Probe
- ③ Where male terminal fits

## FUSE

- When a fuse blows, always investigate the cause to correct it and then replace the fuse.
- Do not use a fuse of a different capacity.
- Do not use wire or any other substitute for the fuse.

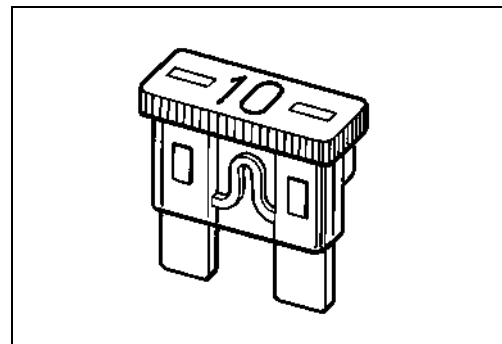

## ECM/VARIOUS SENSORS

- Since each component is a high-precision part, great care should be taken not to apply any sharp impacts during removal and installation.

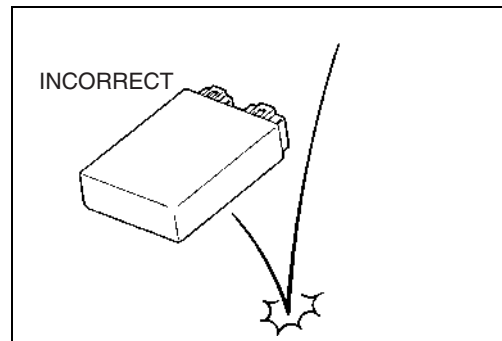

- Be careful not to touch the electrical terminals of the ECM. The static electricity from your body may damage this part.

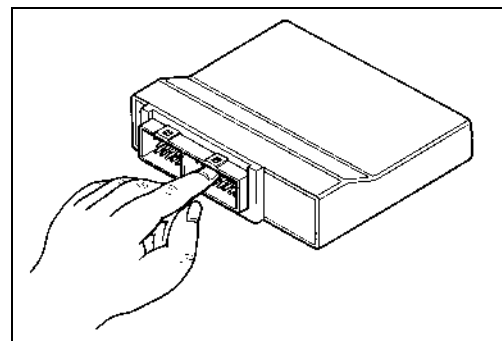

- When disconnecting and connecting the ECM, make sure to turn OFF the ignition switch ①, or electronic parts may get damaged.

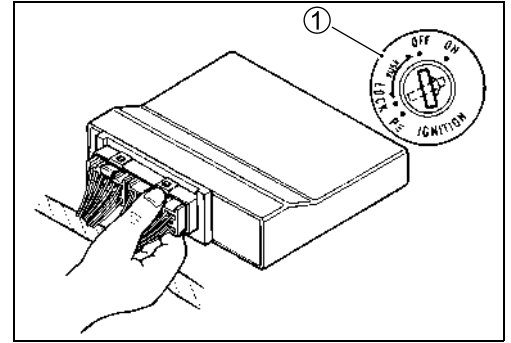

- Battery connection in reverse polarity is strictly prohibited. Such a wrong connection will damage the components of the FI system instantly when reverse power is applied.

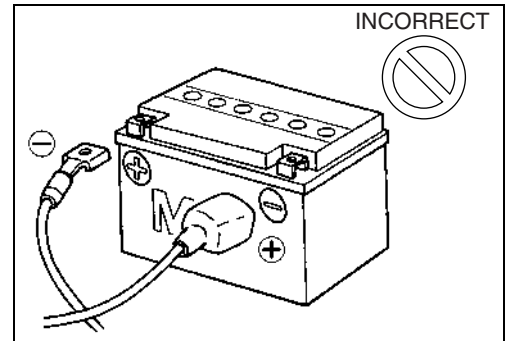

- Removing any battery terminal of a running engine is strictly prohibited. The moment such removal is made, damaging counter electromotive force will be applied to the ECM which may result in serious damage.

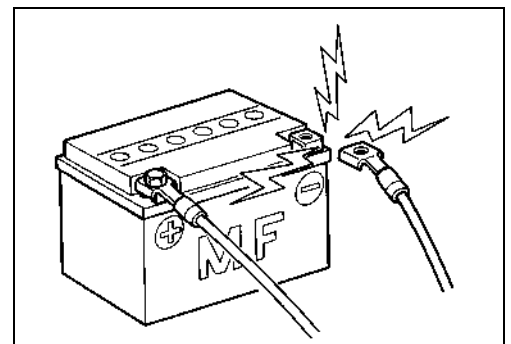

- Before measuring voltage at each terminal, check to make sure that battery voltage is 11 V or higher. Terminal voltage check with a low voltage battery will lead to erroneous diagnosis.

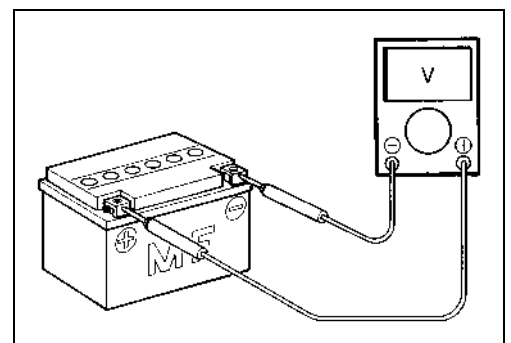

- Never connect any tester (voltmeter, ohmmeter, or whatever) to the ECM when its coupler is disconnected. Otherwise, damage to ECM may result.
- Never connect an ohmmeter to the ECM with its coupler connected. If attempted, damage to ECM or sensors may result.
- Be sure to use a specified voltmeter/ohmmeter. Otherwise, accurate measurements may not be obtained and personal injury may result.

## ELECTRICAL CIRCUIT INSPECTION PROCEDURE

While there are various methods for electrical circuit inspection, described here is a general method to check for open and short circuit using an ohmmeter and a voltmeter.

### OPEN CIRCUIT CHECK

Possible causes for the open circuits are as follows. As the cause can exist in the connector/coupler or terminal, they need to be checked carefully.

- Loose connection of connector/coupler.
- Poor contact of terminal (due to dirt, corrosion or rust, poor contact tension, entry of foreign object etc.).
- Wire harness being open.
- Poor terminal-to-wire connection.
- Disconnect the negative cable from the battery.
- Check each connector/coupler at both ends of the circuit being checked for loose connection. Also check for condition of the coupler lock if equipped.

① Sensor

② ECM

\*1 Check for loose connection.

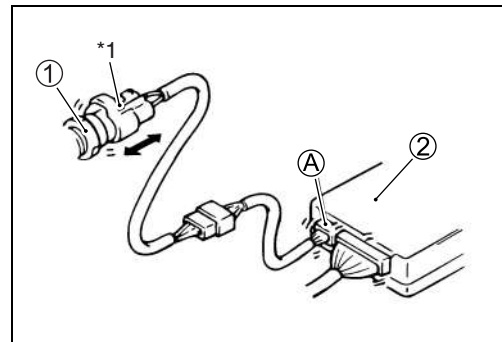

- Using a test male terminal, check the female terminals of the circuit being checked for contact tension.

Check each terminal visually for poor contact (possibly caused by dirt, corrosion, rust, entry of foreign object, etc.). At the same time, check to make sure that each terminal is fully inserted in the coupler and locked.

If contact tension is not enough, rectify the contact to increase tension or replace.

The terminals must be clean and free of any foreign material which could impede proper terminal contact.

\*1 Check contact tension by inserting and removing.

\*2 Check each terminal for bend and proper alignment.

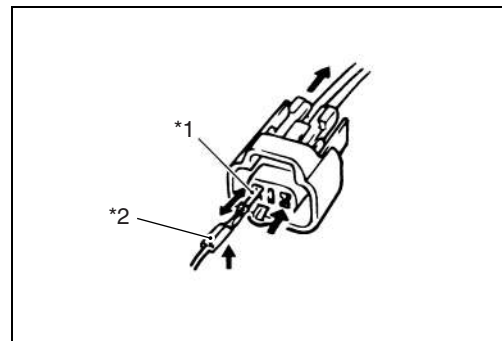

- Using continuity inspect or voltage check procedure as described below, inspect the wire harness terminals for open circuit and poor connection. Locate abnormality, if any.

Ⓐ Looseness of crimping

Ⓑ Open

Ⓒ Thin wire (a few strands left)

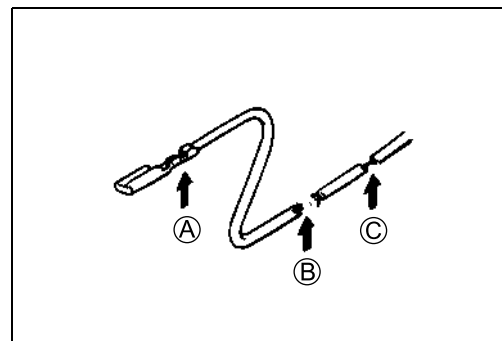



**Continuity check**

- Measure resistance across coupler ② (between ① and ③ in the figure).

If no continuity is indicated (infinity or over limit), the circuit is open between terminals ① and ③.

① ECM

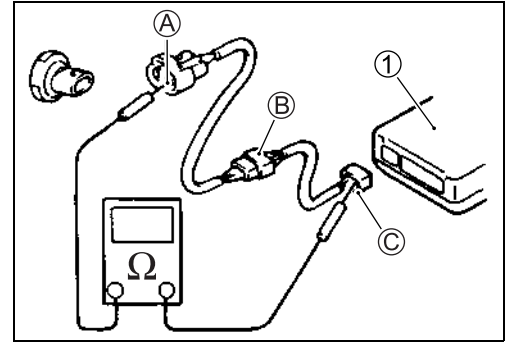

- Disconnect the coupler ② and measure resistance between couplers ① and ②.

If no continuity is indicated, the circuit is open between couplers ① and ②. If continuity is indicated, there is an open circuit between couplers ②' and ③ or an abnormality in coupler ②' or coupler ③.

① ECM

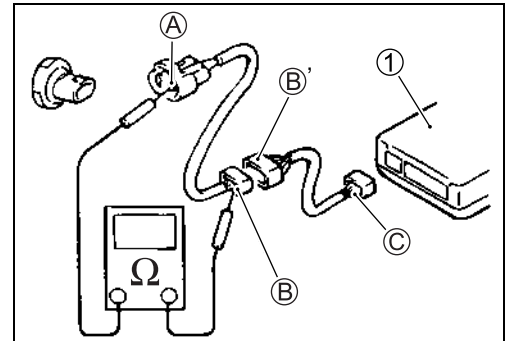

**VOLTAGE CHECK**

If voltage is supplied to the circuit being checked, voltage check can be used as circuit check.

- With all connectors/couplers connected and voltage applied to the circuit being checked, measure voltage between each terminal and body ground.

If measurements were taken as shown in the figure at the right and results are as listed below, it means that the circuit is open between terminals ① and ②.

**Voltage Between:**

- ③ and body ground: Approx. 5 V
- ② and body ground: Approx. 5 V
- ① and body ground: 0 V

Also, if measured values are as listed below, a resistance (abnormality) exists which causes the voltage drop in the circuit between terminals ① and ②.

**Voltage Between:**

- ③ and body ground: Approx. 5 V
  - ② and body ground: Approx. 5 V
  - ① and body ground: 3 V
- } 2 V voltage drop

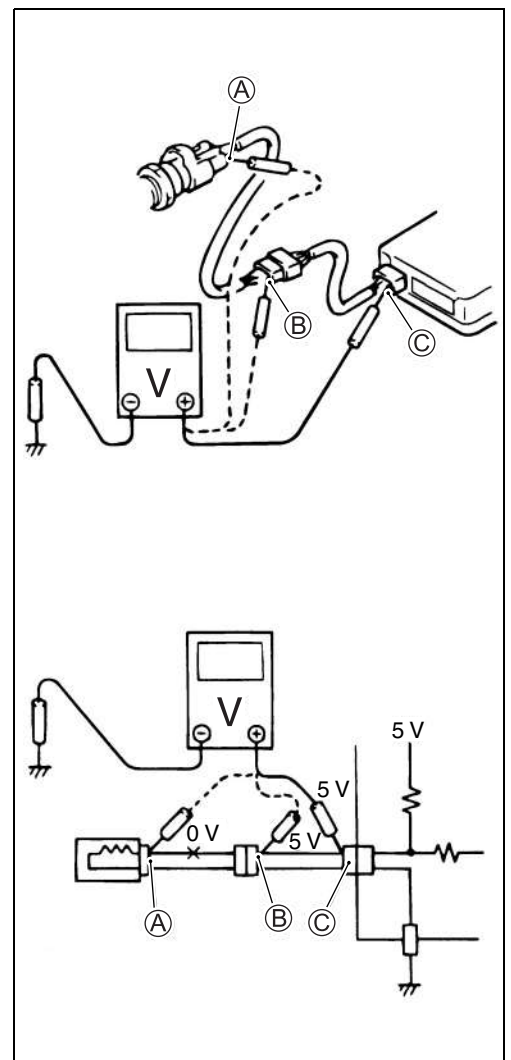

**SHORT CIRCUIT CHECK (WIRE HARNESS TO GROUND)**

- Disconnect the negative cable from the battery.
- Disconnect the connectors/couplers at both ends of the circuit to be checked.

**NOTE:**

If the circuit to be checked branches to other parts as shown, disconnect all connectors/couplers of those parts. Otherwise, diagnosis will be misled.

- Measure resistance between terminal at one end of circuit (A terminal in figure) and body ground. If continuity is indicated, there is a short circuit to ground between terminals A and C.

① Other parts

\*1 To other parts

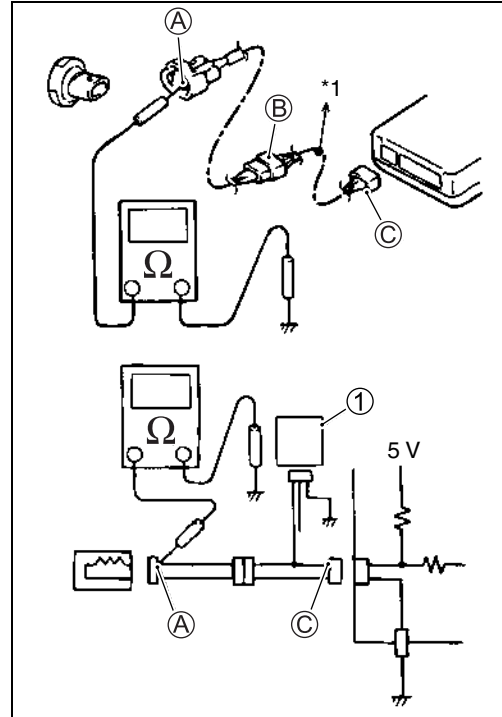

- Disconnect the connector/coupler included in circuit (coupler B) and measure resistance between terminal A and body ground.

If continuity is indicated, the circuit is shorted to the ground between terminals A and B.

① ECM

\*1 To other parts

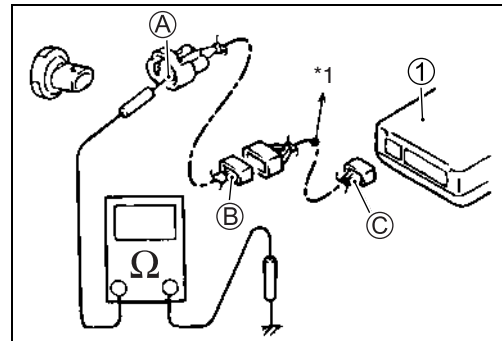

## USING THE MULTI-CIRCUIT TESTER

- Use the Suzuki multi-circuit tester set (09900-25008).
- Use well-charged batteries in the tester.
- Be sure to set the tester to the correct testing range.

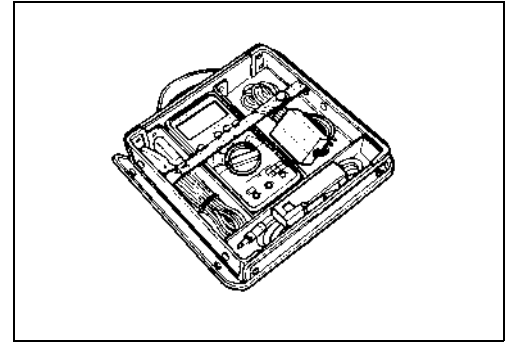

## USING THE TESTER

- Incorrectly connecting the  $\oplus$  and  $\ominus$  probes may cause the inside of the tester to burnout.
- If the voltage and current are not known, make measurements using the highest range.
- When measuring the resistance with the multi-circuit tester ①,  $\infty$  will be shown as 10.00 M $\Omega$  and "1" flashes in the display.
- Check that no voltage is applied before making the measurement. If voltage is applied the tester may be damaged.
- After using the tester, turn the power off.

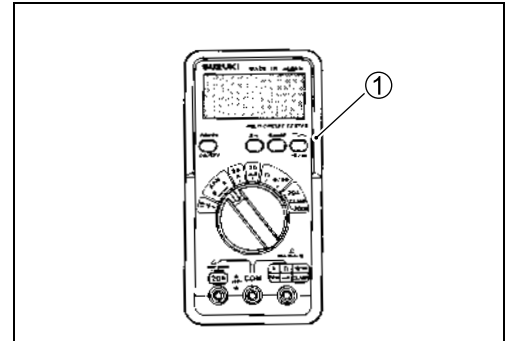

### 09900-25008: Multi-circuit tester set

#### NOTE:

- \* When connecting the multi-circuit tester, use the needle pointed probe to the back side of the lead wire coupler and connect the probes of tester to them.
- \* Use the needle pointed probe to prevent the rubber of the water proof coupler from damage.

### 09900-25009: Needle pointed probe set

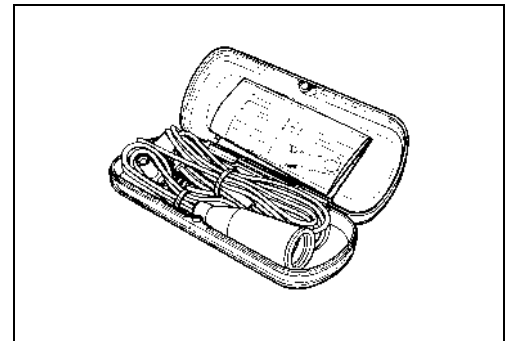

## FI SYSTEM TECHNICAL FEATURES

### INJECTION TIME (INJECTION VOLUME)

The factors to determine the injection time include the basic fuel injection time, which is calculated on the basis of intake air pressure, engine speed and throttle opening angle, and various compensations.

These compensations are determined according to the signals from various sensors that detect the engine and driving conditions.

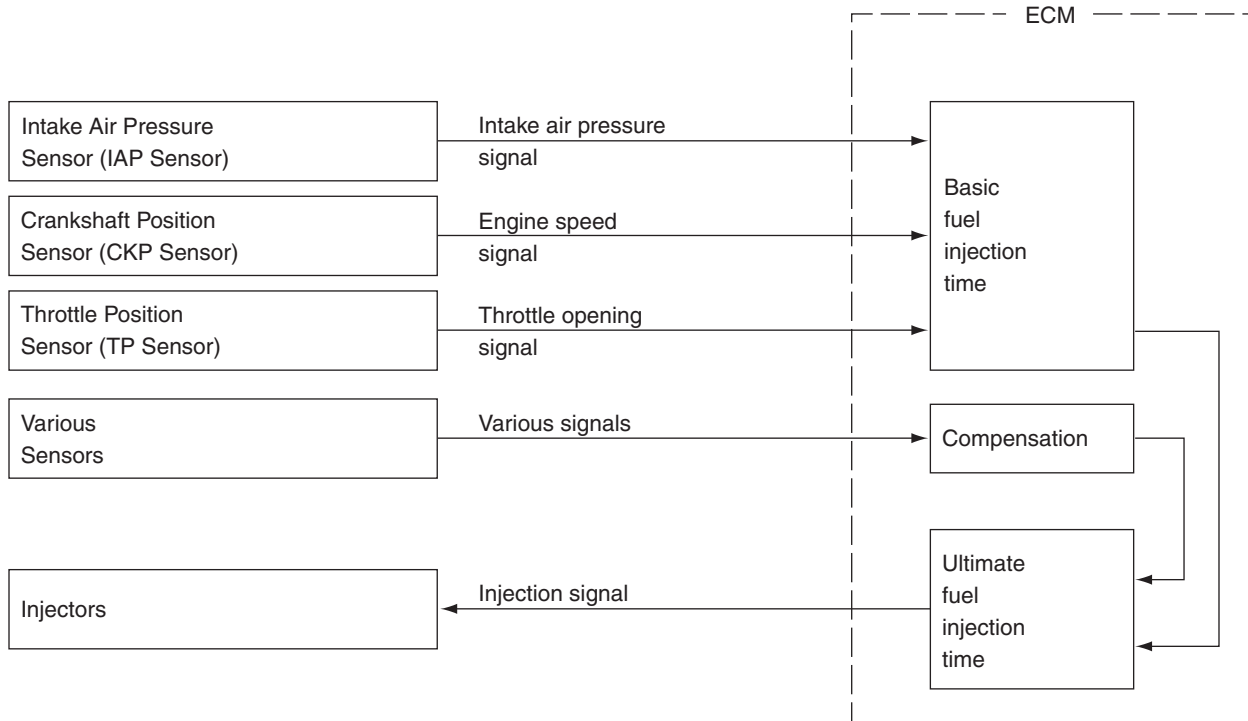

## COMPENSATION OF INJECTION TIME (VOLUME)

The following different signals are output from the respective sensors for compensation of the fuel injection time (volume).

SIGNAL	DESCRIPTION
ENGINE COOLANT TEMPERATURE SENSOR SIGNAL	When engine coolant temperature is low, injection time (volume) is increased.
INTAKE AIR TEMPERATURE SENSOR SIGNAL	When intake air temperature is low, injection time (volume) is increased.
HEATED OXYGEN SENSOR SIGNAL (FOR E-02, 19, 24)	Air/fuel ratio is compensated to the theoretical ratio from density of oxygen in exhaust gasses. The compensation occurs in such a way that more fuel is supplied if detected air/fuel ratio is lean and less fuel is supplied if it is rich.
BATTERY VOLTAGE SIGNAL	ECM operates on the battery voltage and at the same time, it monitors the voltage signal for compensation of the fuel injection time (volume). A longer injection time is needed to adjust injection volume in the case of low voltage.
ENGINE RPM SIGNAL	At high speed, the injection time (volume) is increased.
STARTING SIGNAL	When starting engine, additional fuel is injected during cranking engine.
ACCELERATION SIGNAL/ DECELERATION SIGNAL	During acceleration, the fuel injection time (volume) is increased, in accordance with the throttle opening speed and engine rpm. During deceleration, the fuel injection time (volume) is decreased.

## INJECTION STOP CONTROL

SIGNAL	DESCRIPTION
TIP-OVER SENSOR SIGNAL (FUEL SHUT-OFF)	When the motorcycle tips over, the tip-over sensor sends a signal to the ECM. Then, this signal cuts OFF current supplied to the fuel pump, fuel injectors and ignition coils.
OVER-REV. LIMITER SIGNAL	The fuel injectors stop operation when engine rpm reaches rev. limit rpm.

## FI SYSTEM PARTS LOCATION

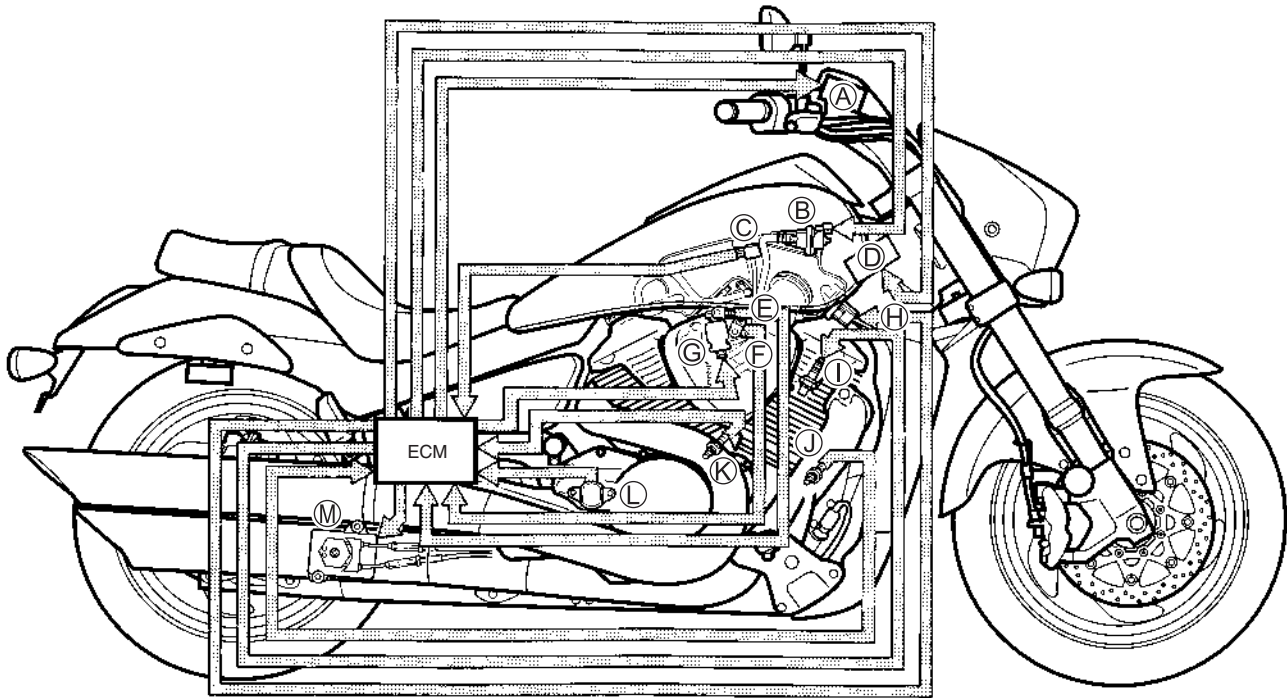

- |   |  |
|---|--|
| Ⓐ Tachometer                                | Ⓑ ISC valve (ISCV)                               |
| Ⓒ Intake air pressure sensor #2 (IAPS)      | Ⓓ Ignition coil #1 (IG COIL)                     |
| Ⓔ Secondary throttle position sensor (STPS) | Ⓕ Throttle position sensor (TPS)                 |
| Ⓖ Secondary throttle valve actuator (STVA)  | Ⓖ PAIR control solenoid valve (For E-02, 19, 24) |
| Ⓘ Ignition coil/plug cap #2                 | Ⓙ HO2 sensor #2 (HO2S) [For E-02, 19, 24]        |
| Ⓚ HO2 sensor #1 (HO2S) [For E-02, 19, 24]   | Ⓛ Gear position switch                           |
| Ⓜ Exhaust control valve actuator (EXCVA)    |  |



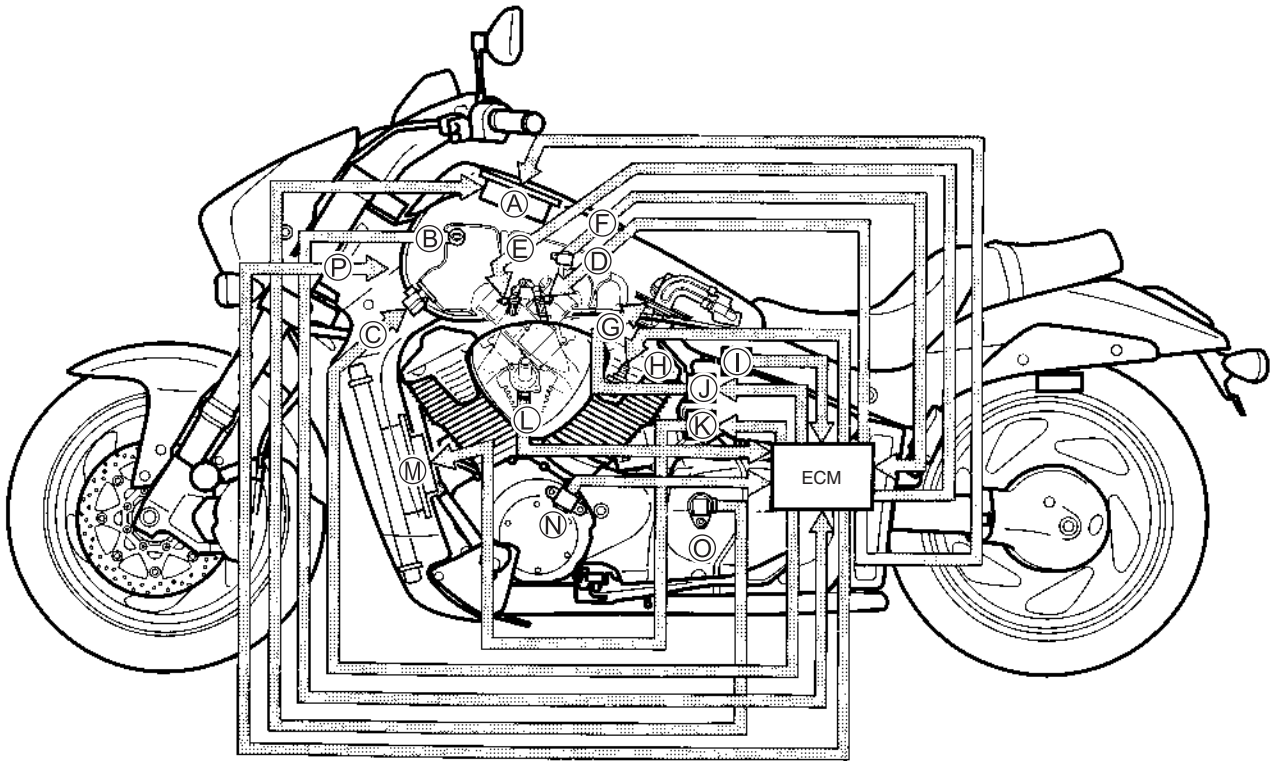

- |                               |  |
|-------------------------------|--|
| Ⓐ Speedometer                 | Ⓑ Intake air temperature sensor (IATS)     |
| Ⓒ PAIR control solenoid valve | Ⓓ Fuel injector #1                         |
| Ⓔ Fuel injector #2            | Ⓕ Intake air pressure sensor #1 (IAPS)     |
| Ⓖ Fuel pump                   | Ⓗ Ignition coil/plug cap #1                |
| Ⓛ Tip-over sensor (TOS)       | Ⓜ Fuel pump relay (FP RELAY)               |
| Ⓚ Cooling fan relay           | Ⓝ Engine coolant temperature sensor (ECTS) |
| Ⓜ Cooling fan                 | Ⓝ Crankshaft position sensor (CKPS)        |
| Ⓞ Speedmeter sensor           | Ⓟ Ignition coil #2 (IG COIL)               |

# FI SYSTEM WIRING DIAGRAM

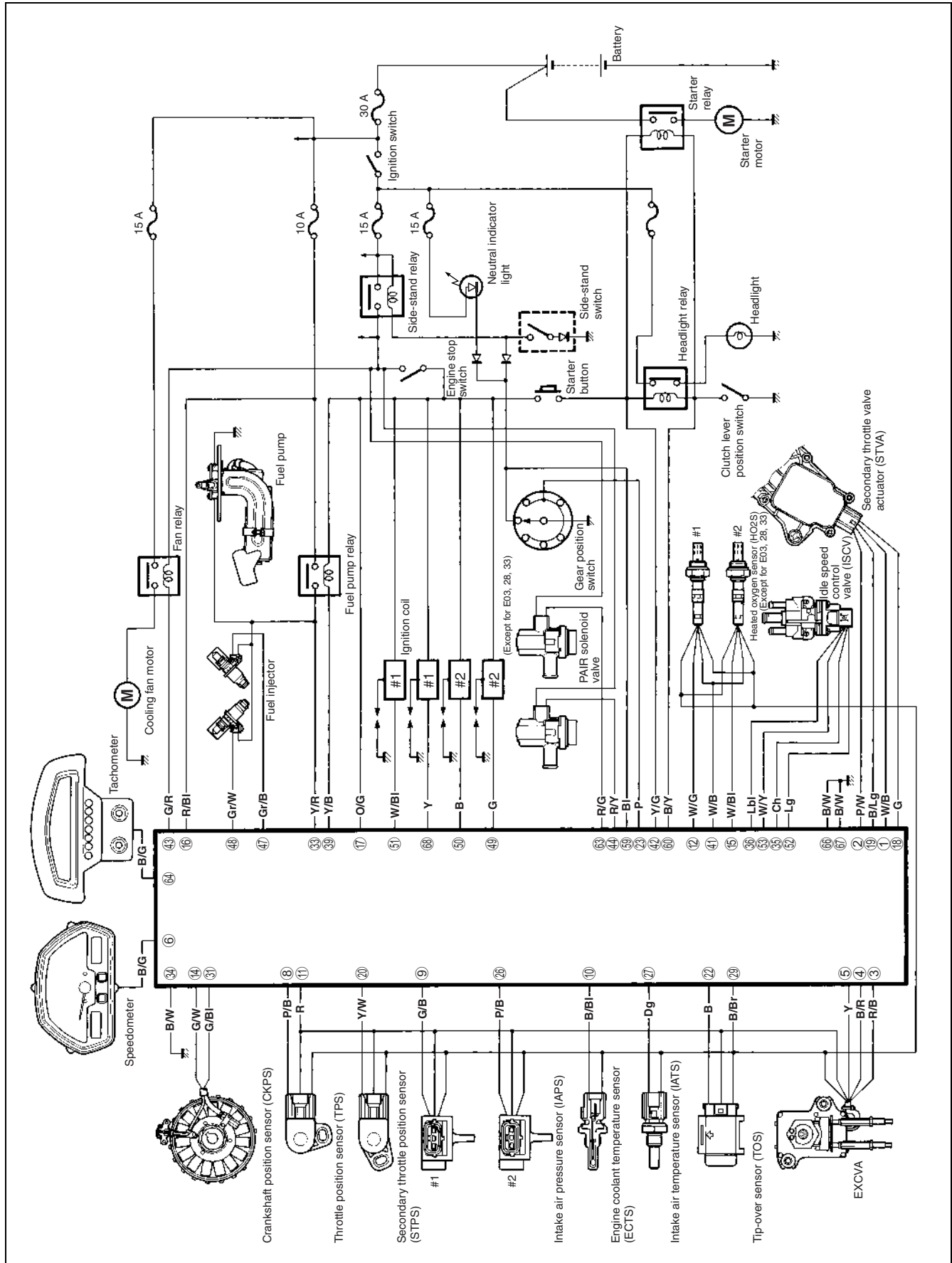

## ECM TERMINAL

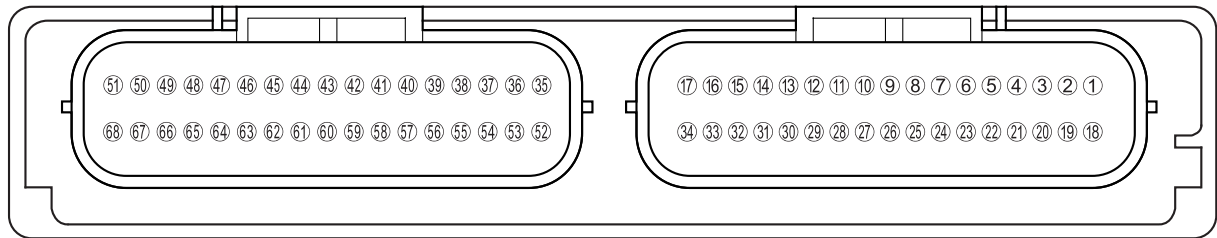

TERMINAL NO.	CIRCUIT	TERMINAL NO.	CIRCUIT
①	STVA signal (STVA. 2A)	⑱	STVA signal (STVA. 2B)
②	STVA signal (STVA. 1A)	⑲	STVA signal (STVA. 1B)
③	EXCVA power (MO-)	⑳	STP sensor signal (STP)
④	EXCVA power (MO+)	㉑	Ignition switch signal
⑤	EXCVA position sensor (MPS)	㉒	TO sensor signal (TOS)
⑥	Serial data for speedometer	㉓	GP switch signal (GP)
⑦	Blank	㉔	Blank
⑧	TP sensor signal (TP)	㉕	Blank
⑨	IAP sensor signal #1 (IAP. 1)	㉖	IAP sensor signal #2 (IAP. 2)
⑩	ECT sensor signal (ECT)	㉗	IAT sensor signal (IAT)
⑪	Power source for sensors (VCC)	㉘	Blank
⑫	HO2 sensor signal #1 (HO2S) [For E-02, 19, 24]	㉙	Sensors ground (E2)
⑬	Blank	㉚	Blank
⑭	CKP sensor signal (CKP+)	㉛	CKP sensor signal (CKP-)
⑮	HO2 sensor signal #2 (HO2S) [For E-02, 19, 24]	㉜	Serial data for self-diagnosis
⑯	Power source for back-up	㉝	Power source for fuel injector (VM)
⑰	Power source	㉞	ECM ground (E1)

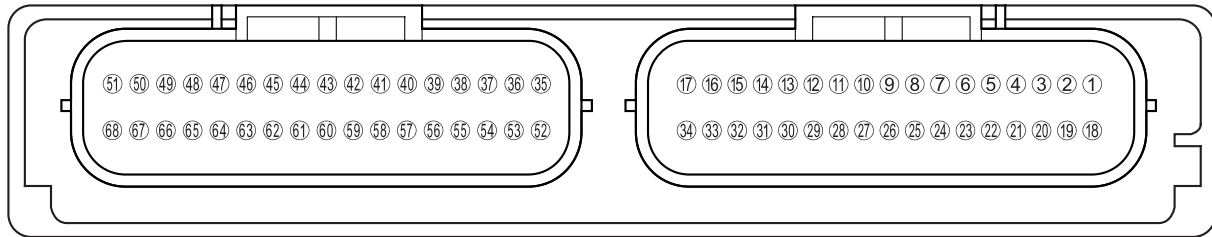

TERMINAL NO.	CIRCUIT	TERMINAL NO.	CIRCUIT
③⑤	ISC signal (ISC, 2A)	⑤②	ISC signal (ISC, 2B)
③⑥	ISC signal (ISC, 1A)	⑤③	ISC signal (ISC, 1B)
③⑦	—	⑤④	—
③⑧	—	⑤⑤	—
③⑨	Fuel pump relay (FP Relay)	⑤⑥	—
④①	—	⑤⑦	—
④②	HO2 sensor heater (HO2, H)	⑤⑧	Mode select switch
④③	Starter relay	⑤⑨	Neutral switch
④④	Cooling fan relay (FAR)	⑥①	Clutch position switch
④⑤	Rear cylinder PAIR control solenoid #1 valve (PAIR. #1)	⑥②	—
④⑥	Blank	⑥③	—
④⑦	Blank	⑥④	PAIR control solenoid valve #2 (PAIR. #2) [Except for E-03, 28, 33]
④⑧	Fuel injector #2 (#21)	⑥⑤	Tachometer
④⑨	Fuel injector #1 (#11)	⑥⑥	—
⑤①	Ignition coil #2	⑥⑦	Ground
⑤②	Ignition coil #2	⑥⑧	Ground for ignition system
⑤③	Ignition coil #1	⑥⑨	Ignition coil #1

## SELF-DIAGNOSIS FUNCTION

The self-diagnosis function is incorporated in the ECM. The function has two modes, “User mode” and “Dealer mode”. The user can only be notified by the LCD (DISPLAY) panel and LED (FI indicator light). To check the function of the individual FI system devices, the dealer mode is provided. In this check, the special tool is necessary to read the code of the malfunction items.

### USER MODE

MALFUNCTION	LCD (DISPLAY) INDICATION <sup>Ⓐ</sup>	FI INDICATOR LIGHT INDICATION <sup>Ⓑ</sup>	INDICATION MODE
“NO”	Odometer *1	—	—
“YES”	Odometer (*1) and “FI” letters *2	FI indicator light turns ON.	Each 2 sec. Odometer (*1) and “FI” are indi- cated alternately.
Engine can start	*2		
Engine can not start	“FI” letter *3	FI indicator light turns ON and blinks.	“FI” is indicated continuously.

\*1

Current letter displayed any one of the Odometer, Tripmeter or Clock.

\*2

When one of the signals is not received by ECM, the fail-safe circuit works and injection is not stopped. In this case, “FI” and Odometer (\*1) are indicated in the LCD panel and motorcycle can run.

\*3

The injection signal is stopped, when the crankshaft position sensor signal, tip-over sensor signal, both #1/#2 ignition signals, both #1/#2 injector signals, fuel pump relay signal or ignition switch signal is not sent to ECM. In this case, “FI” is indicated in the LCD panel. Motorcycle does not run.

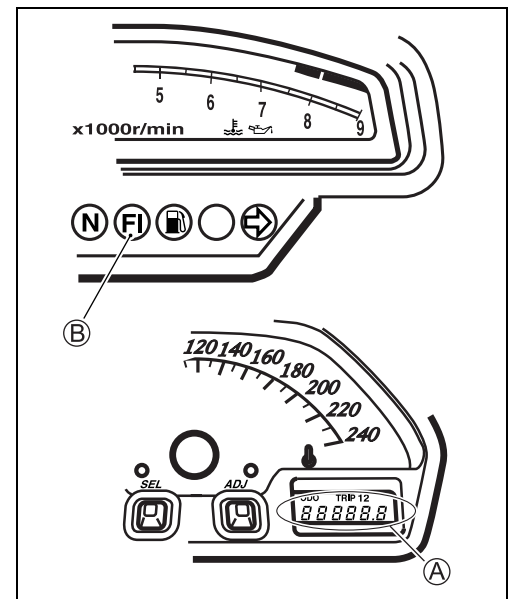

“CHEC”: The LCD panel indicates “CHEC” when no communication signal from the ECM is received for 3 seconds.

For Example

: The ignition switch is turned ON, and the engine stop switch is turned OFF. In this case, the speedometer does not receive any signal from ECM, and the panel indicates “CHEC”.

If CHEC is indicated, the LCD does not indicate the trouble code. It is necessary to check the wiring harness between ECM and speedometer couplers.

The possible cause of this indication is as follows;

Engine stop switch is in OFF position. Side-stand/ignition inter-lock system is not working. Ignition fuse is burnt.

## DEALER MODE

The defective function is memorized in the computer. Use the special tool's coupler to connect to the dealer mode coupler. The memorized malfunction code is displayed on LCD (DISPLAY) panel. Malfunction means that the ECM does not receive signal from the devices. These affected devices are indicated in the code form.

 09930-82720: Mode select switch

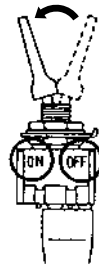

### CAUTION

**Before checking the malfunction code, do not disconnect the ECM lead wire couplers. If the couplers from the ECM are disconnected, the malfunction code memory is erased and the malfunction code can not be checked.**

MALFUNCTION	LCD (DISPLAY) INDICATION	FI INDICATOR LIGHT INDICATION	INDICATION MODE
"NO"	C00		—
"YES"	C**code is indicated from small numeral to large one.	FI indicator light turns OFF.	For each 2 sec., code is indicated.



CODE	MALFUNCTION PART	REMARKS
C00	None	No defective part
C12	Crankshaft position sensor (CKPS)	Pick-up coil signal, Generator
C13	Intake air pressure sensor #2 (IAPS #2)	For Front cylinder
C14	Throttle position sensor (TPS)	*1
C15	Engine coolant temp. sensor (ECTS)	
C17	Intake air pressure sensor #1 (IAPS #1)	For Rear cylinder
C21	Intake air temp. sensor (IATS)	
C23	Tip-over sensor (TOS)	
C24	Ignition signal #1 (IG coil #1.1)	For Rear cylinder
C25	Ignition signal #2 (IG coil #2.1)	For Front cylinder
C26	Ignition signal #1 (IG coil #1.2)	For Rear cylinder
C27	Ignition signal #2 (IG coil #2.2)	For Front cylinder
C28	Secondary throttle valve actuator (STVA)	
C29	Secondary throttle position sensor (STPS)	*2
C31	Gear position signal (GP switch)	
C32	Injector signal #1 (FI #1)	For Rear cylinder
C33	Injector signal #2 (FI #2)	For Front cylinder
C40	Idle speed control valve (ISC valve)	
C41	Fuel pump control system (FP control system)	Fuel pump, fuel pump relay
C42	Ignition switch signal (IG switch signal)	Anti-theft
C44	Heated oxygen sensor #2 (HO2S #2)	For E-02, 19, 24
C46	Exhaust control valve actuator (EXCVA)	
C49	PAIR control solenoid valve #2 (PAIR valve #2)	Except for E-03, 28, 33
C60	Cooling fan control system	Cooling fan relay
C61	PAIR control solenoid valve #1 (PAIR #1)	
C64	Heated oxygen sensor #1 (HO2S #1)	For E-02, 19, 24

In the LCD (DISPLAY) panel, the malfunction code is indicated from small code to large code.

\*1

To get the proper signal from the throttle position sensor, the sensor basic position is indicated in the LCD (DISPLAY) panel. The malfunction code is indicated in three digits. In front of the three digits, a line appears in any of the three positions, upper, middle or lower line. If the indication is upper or lower line when engine rpm is 900 r/min, slightly turn the throttle position sensor and bring the line to the middle.

In the normal condition, the throttle valve stop screw pushes throttle valves slightly, and middle line will be indicated.

\*2

When the secondary throttle valve actuator and secondary throttle position sensor signals are not sent to ECM. In this case, C28 and C29 are indicated alternately.

## TPS ADJUSTMENT

1. Warm up the engine and check the engine idle r/min.  
Adjust the engine rpm to 900 r/min if necessary. (☞ 6-22)
2. Connect the special tool (Mode select switch) to the dealer mode coupler at the wiring harness.

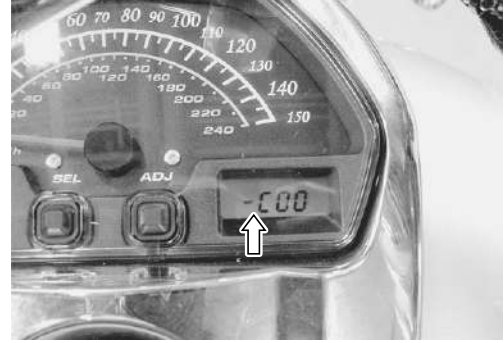

3. Remove the fuel tank. (☞ 6-3)
4. Remove the right air cleaner box. (☞ 6-13)
5. If the throttle position sensor adjustment is necessary, loosen the screw and turn the throttle position sensor and bring the line to the middle.
6. Then, tighten the screw to fix the throttle position sensor.



**TOOL** 09930-11950: Torx wrench  
09930-82720: Mode select switch

The LCD displays the line for 0.4 sec. at a time, and when such a display repeats two times, it indicates the current position where the sensor is fixed.

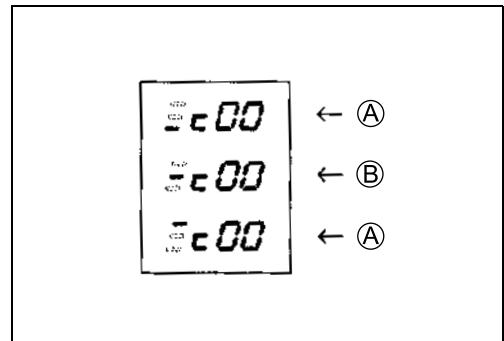

- (A) Incorrect  
(B) Correct position

## FAIL-SAFE FUNCTION

FI system is provided with fail-safe function to allow the engine to start and the motorcycle to run in a minimum performance necessary even under malfunction condition.

ITEM	FAIL-SAFE MODE	STARTING ABILITY	RUNNING ABILITY
IAP sensor	Intake air pressure is fixed to 760 mmHg.	“YES”	“YES”
TP sensor	The throttle opening is fixed to full open position.	“YES”	“YES”
ECT sensor	Engine coolant temperature value is fixed to 80 °C (176 °F).	“YES”	“YES”
IAT sensor	Intake air temperature value is fixed to 40 °C (104 °F).	“YES”	“YES”
Ignition signal	#1.1 or #1.2 Ignition-off	“YES”	“YES”
		#1 cylinder can run.	
	#2.1 or #2.2 Ignition-off	“YES”	“YES”
		#2 cylinder can run.	
Injection signal	#1 Fuel-cut	“YES”	“YES”
		#2 cylinder can run.	
	#2 Fuel-cut	“YES”	“YES”
		#1 cylinder can run.	
Secondary throttle valve actuator	Secondary throttle valve is fixed to full close position. When motor disconnection or lock occurs, power from ECM is shut off.	“YES”	“YES”
STP sensor	Secondary throttle valve is fixed to full close position.	“YES”	“YES”
Gear position signal	Gear position signal is fixed to 5th gear.	“YES”	“YES”
Heated oxygen sensor (E-02, 19, 24)	Fuel-air compensation ratio is fixed to normal condition.	“YES”	“YES”
PAIR control solenoid valve	ECM stops controlling PAIR control solenoid valve.	“YES”	“YES”
EXCV actuator	EXCV actuator is fixed to full open position. When motor disconnection or lock occurs, power from ECM is shut off.	“YES”	“YES”
ISC valve	When motor disconnection or lock occurs, power from ECM is shut off.	“YES”	“YES”

The engine can start and can run even if the above signal is not received from each sensor. But, the engine running condition is not complete, providing only emergency help (by fail-safe circuit). In this case, it is necessary to bring the motorcycle to the workshop for complete repair.

When two ignition signals or two injector signals are not received by ECM, the fail-safe circuit can not work and ignition or injection is stopped.

## FI SYSTEM TROUBLESHOOTING

### CUSTOMER COMPLAINT ANALYSIS

Record details of the problem (failure, complaint) and how it occurred as described by the customer. For this purpose, use of such an inspection form such as below will facilitate collecting information required for proper analysis and diagnosis.

#### EXAMPLE: CUSTOMER PROBLEM INSPECTION FORM

User name:	Model:	VIN:	
Date of issue:	Date Reg.	Date of problem:	Mileage:

Malfunction indicator lamp condition (LED)	<input type="checkbox"/> Always ON <input type="checkbox"/> Sometimes ON <input type="checkbox"/> Always OFF <input type="checkbox"/> Good condition
Malfunction display/code (LCD)	User mode: <input type="checkbox"/> No display <input type="checkbox"/> Malfunction display (            )
	Dealer mode: <input type="checkbox"/> No code <input type="checkbox"/> Malfunction code (            )

PROBLEM SYMPTOMS	
<input type="checkbox"/> <b>Difficult Starting</b> <input type="checkbox"/> No cranking <input type="checkbox"/> No initial combustion <input type="checkbox"/> No combustion <input type="checkbox"/> Poor starting at ( <input type="checkbox"/> cold <input type="checkbox"/> warm <input type="checkbox"/> always) <input type="checkbox"/> Other _____	<input type="checkbox"/> <b>Poor Driveability</b> <input type="checkbox"/> Hesitation on acceleration <input type="checkbox"/> Back fire/ <input type="checkbox"/> After fire <input type="checkbox"/> Lack of power <input type="checkbox"/> Surging <input type="checkbox"/> Abnormal knocking <input type="checkbox"/> Engine rpm jumps briefly <input type="checkbox"/> Other _____
<input type="checkbox"/> <b>Poor Idling</b> <input type="checkbox"/> Poor fast idle <input type="checkbox"/> Abnormal idling speed ( <input type="checkbox"/> High <input type="checkbox"/> Low) (        r/min) <input type="checkbox"/> Unstable <input type="checkbox"/> Hunting (        r/min to        r/min) <input type="checkbox"/> Other _____	<input type="checkbox"/> <b>Engine Stall when</b> <input type="checkbox"/> Immediately after start <input type="checkbox"/> Throttle valve is opened <input type="checkbox"/> Throttle valve is closed <input type="checkbox"/> Load is applied <input type="checkbox"/> Other _____
<input type="checkbox"/> OTHERS:	

MOTORCYCLE/ENVIRONMENTAL CONDITION WHEN PROBLEM OCCURS	
<b>Environmental condition</b>	
Weather	<input type="checkbox"/> Fair <input type="checkbox"/> Cloudy <input type="checkbox"/> Rain <input type="checkbox"/> Snow <input type="checkbox"/> Always <input type="checkbox"/> Other _____
Temperature	<input type="checkbox"/> Hot <input type="checkbox"/> Warm <input type="checkbox"/> Cool <input type="checkbox"/> Cold (      °C/      °F) <input type="checkbox"/> Always
Frequency	<input type="checkbox"/> Always <input type="checkbox"/> Sometimes (      times/      day, month) <input type="checkbox"/> Only once <input type="checkbox"/> Under certain condition
Road	<input type="checkbox"/> Urban <input type="checkbox"/> Suburb <input type="checkbox"/> Highway <input type="checkbox"/> Mountainous ( <input type="checkbox"/> Uphill <input type="checkbox"/> Downhill) <input type="checkbox"/> Tarmacadam <input type="checkbox"/> Gravel <input type="checkbox"/> Other _____
<b>Motorcycle condition</b>	
Engine condition	<input type="checkbox"/> Cold <input type="checkbox"/> Warming up phase <input type="checkbox"/> Warmed up <input type="checkbox"/> Always <input type="checkbox"/> Other at starting <input type="checkbox"/> Immediately after start <input type="checkbox"/> Racing without load <input type="checkbox"/> Engine speed (      r/min)
Motorcycle condition	During driving: <input type="checkbox"/> Constant speed <input type="checkbox"/> Accelerating <input type="checkbox"/> Decelerating <input type="checkbox"/> Right hand corner <input type="checkbox"/> Left hand corner <input type="checkbox"/> At stop <input type="checkbox"/> Motorcycle speed when problem occurs (      km/h,      mile/h) <input type="checkbox"/> Other _____

**NOTE:**

The above form is a standard sample. The form should be modified according to conditions and characteristics of each market.

**VISUAL INSPECTION**

- Prior to diagnosis using the mode select switch or SDS, perform the following visual inspections. The reason for visual inspection is that mechanical failures (such as oil leakage) cannot be displayed on the screen with the use of mode select switch or SDS.
- \* Engine oil level and leakage (☞ 2-17)
- \* Engine coolant level and leakage (☞ 2-20)
- \* Fuel level and leakage (☞ 2-16 and 10-36)
- \* Clogged air cleaner element (☞ 2-4)
- \* Battery condition (☞ 10-43)
- \* Throttle cable play (☞ 2-19)
- \* Vacuum hoses looseness, bend and disconnection
- \* Broken fuse
- \* FI light operation (☞ 5-17 and 10-33)
- \* Each warning light operation (☞ 10-33)
- \* Speedometer operation (☞ 10-37)
- \* Exhaust gas leakage and noise (☞ 2-6)
- \* Each coupler disconnection
- \* Clogged radiator fins (☞ 8-6)

## SELF-DIAGNOSTIC PROCEDURES

### NOTE:

- \* Don't disconnect couplers from the ECM, the battery cable from the battery, ECM ground wire harness from the engine or main fuse before confirming the malfunction code (self-diagnostic trouble code) stored in memory. Such disconnection will erase the memorized information in ECM memory.
- \* Malfunction code stored in ECM memory can be checked by the special tool.
- \* Before checking malfunction code, read SELF-DIAGNOSIS FUNCTION "USER MODE and DEALER MODE" (☞ 5-17 and 5-18) carefully to have good understanding as to what functions are available and how to use it.
- \* Be sure to read "PRECAUTIONS IN SERVICING" (☞ 5-3) before inspection and observe what is written there.
- Remove the left frame lower side cover. (☞ 3-6)
- Connect the special tool to the dealer mode coupler at the wiring harness, and start the engine or crank the engine for more than 4 seconds.
- Turn the special tool's switch ON and check the malfunction code to determine the malfunction part.

 **09930-82720: Mode select switch**

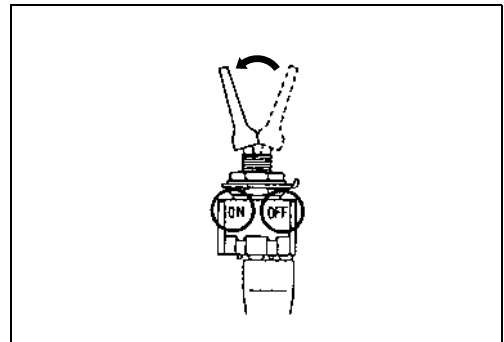

## SELF-DIAGNOSIS RESET PROCEDURE

- After repairing the trouble, turn OFF the ignition switch and turn ON again.
- If the malfunction code indicates (C00), the malfunction is cleared.
- Disconnect the special tool from the dealer mode coupler.

### NOTE:

- \* Even though the malfunction code (C00) is indicated, the previous malfunction history code still remains stored in the ECM. Therefore, erase the history code memorized in the ECM using SDS.
- \* The malfunction code is memorized in the ECM also when the wire coupler of any sensor is disconnected. Therefore, when a wire coupler has been disconnected at the time of diagnosis, erase the stored malfunction history code using SDS.





## USE OF SDS DIAGNOSTIC PROCEDURES

- \* Don't disconnect couplers from ECM, the battery cable from the battery, ECM ground wire harness from the engine or main fuse before confirming the malfunction code (self-diagnostic trouble code) stored in memory. Such disconnection will erase the memorized information in ECM memory.
  - \* Malfunction code stored in ECM memory can be checked by the SDS.
  - \* Be sure to read "PRECAUTIONS IN SERVICING" (☞ 5-3) before inspection and observe what is written there.
- Remove the left frame lower side cover. (☞ 3-6)
  - Set up the SDS tool. (Refer to the SDS operation manual for further details.)
  - Read the DTC (Diagnostic Trouble Code) and show data when trouble (displaying data at the time of DTC) according to instructions displayed on SDS.
  - Not only is SDS used for detecting Diagnostic Trouble Codes but also for reproducing and checking on screen the failure condition as described by customers using the trigger.
  - How to use trigger. (Refer to the SDS operation manual for further details.)

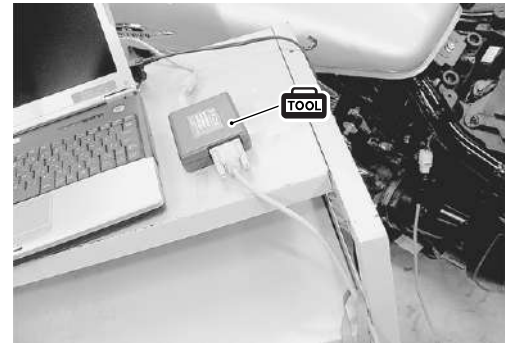

**TOOL** 09904-41010: SDS set tool  
99565-01010-007: CD-ROM Ver. 7

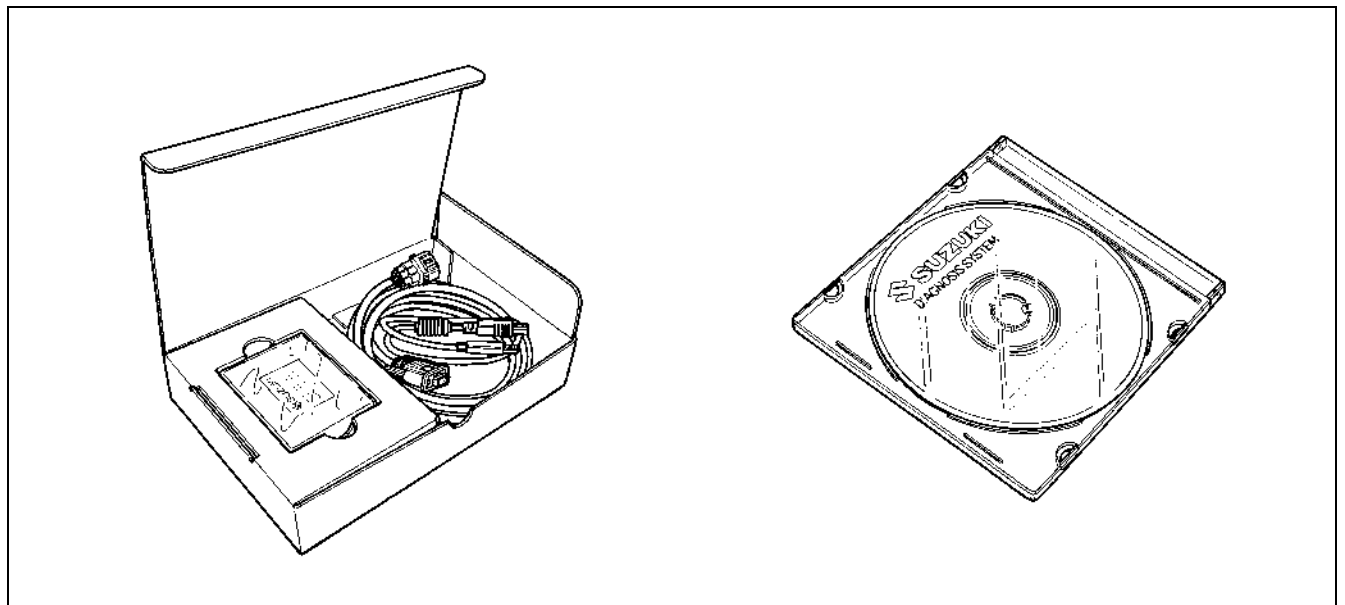

## USE OF SDS DIAGNOSIS RESET PROCEDURE

- After repairing the trouble, turn OFF the ignition switch and turn ON again.
- Click the DTC inspection button ①.
- Check the DTC.
- The previous malfunction history code (Past DTC) still remains stored in the ECM. Therefore, erase the history code memorized in the ECM using SDS tool.

### NOTE:

The malfunction code is memorized in the ECM also when the wire coupler of any sensor is disconnected. Therefore, when a wire coupler has been disconnected at the time of diagnosis, erase the stored malfunction history code using SDS.

- Click “Clear” ② to delete history code (Past DTC).

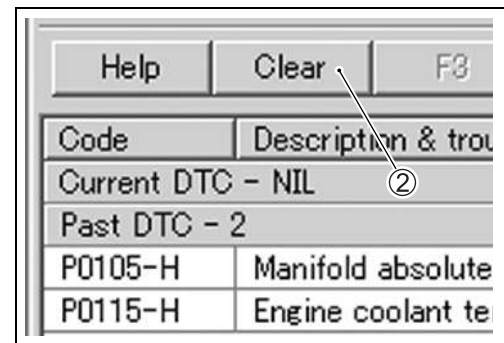
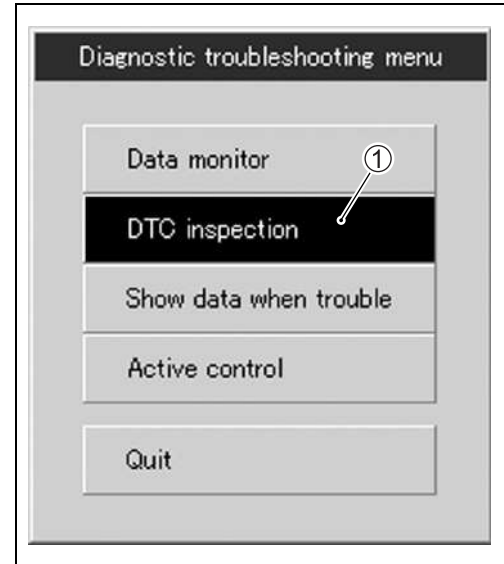

- Follow the displayed instructions.

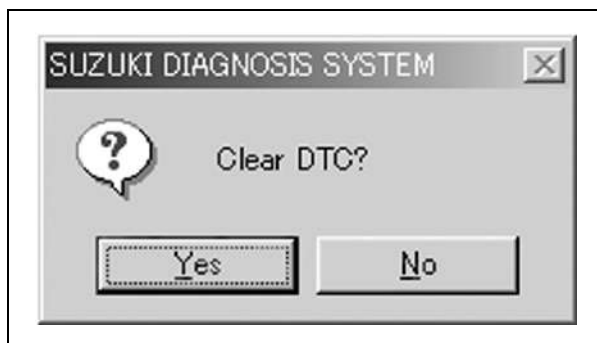

- Check that both “Current DTC” ③ and “Past DTC” ④ are deleted (NIL).



## SHOW DATA WHEN TROUBLE (DISPLAING DATA AT THE TIME OF DTC)

ECM stores the engine and driving conditions (in the form of data as shown in the figure) at the moment of the detection of a malfunction in its memory. This data is called “Show data when trouble”.

Therefore, it is possible to know engine and driving conditions (e.g., whether the engine was warm or not, where the motorcycle was running or stopped) when a malfunction was detected by checking the show data when trouble. This show data when trouble function can record the maximum of two Diagnostic Trouble Codes in the ECM.

Also, ECM has a function to store each show data when trouble for two different malfunctions in the order as the malfunction is detected. Utilizing this function, it is possible to know the order of malfunctions that have been detected. Its use is helpful when rechecking or diagnosing a trouble.

Item	Pre-detect	Detect poi...	Post-dete...
Engine speed	0	0	0
Throttle position	28.9	28.9	28.9
Manifold absolute pressure 1	135.2	144.3	145.6
Engine coolant / oil temperature	24.0	24.0	24.0
Gear position	N	N	N
Secondary throttle actuator position sensor	96.1	96.1	98.4

- Click “Show data when trouble” ① to display the data. By clicking the drop down button ②, either “Failure #1” or “Failure #2” can be selected.

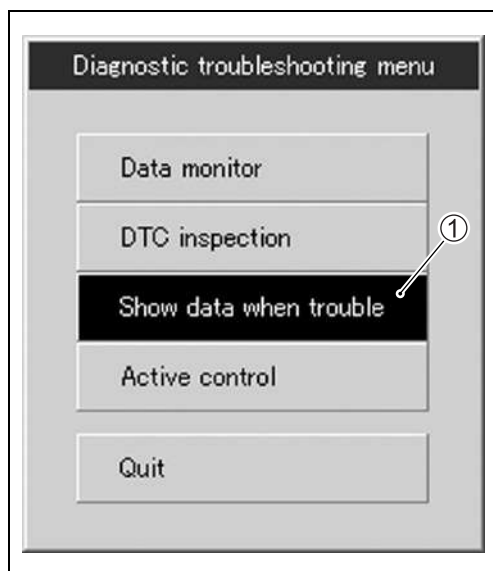

Item	Pre-d
Engine speed	
Throttle position	
Manifold absolute pressure 1	
Engine coolant / oil temperature	
Gear position	
Secondary throttle actuator position sensor	

**MALFUNCTION CODE AND DEFECTIVE CONDITION**

DTC No.		DETECTED ITEM	DETECTED FAILURE CONDITION	CHECK FOR
C00		NO FAULT	—————	—————
C12		CKP sensor	The signal does not reach ECM for 3 sec. or more, after receiving the starter signal.	CKP sensor wiring and mechanical parts CKP sensor, lead wire/coupler connection
P0335				
C13/C17		IAP sensor	The sensor should produce following voltage. $0.5\text{ V} \leq \text{sensor voltage} < 4.85\text{ V}$ In other than the above range, C13 (P1750) or C17 (P0105) is indicated.	IAP sensor, lead wire/coupler connection
P1750/P0105				
P1750/ P0105	H			
	L	Sensor voltage is lower than specified value.	IAP sensor circuit open or shorted to ground or VCC circuit open	
C14		TP sensor	The sensor should produce following voltage. $0.2\text{ V} \leq \text{sensor voltage} < 4.80\text{ V}$ In other than the above range, C14 (P0120) is indicated.	TP sensor, lead wire/coupler connection
P0120				
P0120	H			
	L	Sensor voltage is lower than specified value.	TP sensor circuit open or shorted to ground or VCC circuit open	
C15		ECT sensor	The sensor voltage should be the following. $0.15\text{ V} \leq \text{sensor voltage} < 4.85\text{ V}$ In other than the above range, C15 (P0115) is indicated.	ECT sensor, lead wire/coupler connection
P0115				
P0115	H			
	L	Sensor voltage is lower than specified value.	ECT sensor circuit shorted to ground	
C21		IAT sensor	The sensor voltage should be the following. $0.15\text{ V} \leq \text{sensor voltage} < 4.85\text{ V}$ In other than the above range, C21 (P0110) is indicated.	IAT sensor, lead wire/coupler connection
P0110				
P0110	H			
	L	Sensor voltage is lower than specified value.	IAT sensor circuit shorted to ground	

DTC No.	DETECTED ITEM	DETECTED FAILURE CONDITION	CHECK FOR
C23	TO sensor	The sensor voltage should be the following for 2 sec. and more, after ignition switch is turned ON.	TO sensor, lead wire/coupler connection
P1651		$0.2\text{ V} \leq \text{sensor voltage} < 4.8\text{ V}$ In other than the above value, C23 (P1651) is indicated.	
P1651		H	Sensor voltage is higher than specified value.
	L	Sensor voltage is lower than specified value.	TO sensor circuit open or shorted to ground or VCC circuit open
C24/C25 C26/C27	Ignition signal	CKP sensor (pick-up coil) signal is produced, but signal from ignition coil is interrupted 8 times or more continuously. In this case, the code C24 (P0351), C25 (P0352), C26 (P0353) or C27 (P0354) is indicated.	Ignition coil, wiring/coupler connection, power supply from the battery
P0351/P0352 P0353/P0354			
C28	Secondary throttle valve actuator	When no actuator control signal is supplied from the ECM, communication signal does not reach ECM or operation voltage does not reach STVA motor, C28 (P1655) is indicated. STVA can not operate.	STVA motor, STVA lead wire/coupler
P1655			
C29	STP sensor	The sensor should produce following voltage.	STP sensor, lead wire/coupler connection
P1654		$0.15\text{ V} \leq \text{sensor voltage} < 4.85\text{ V}$ In other than the above range, C29 (P1654) is indicated.	
P1654		H	Sensor voltage is higher than specified value.
	L	Sensor voltage is lower than specified value.	STP sensor circuit open or shorted to ground or VCC circuit open
C31	Gear position signal	Gear position signal voltage should be higher than the following for 3 seconds and more. Gear position sensor voltage $> 0.6\text{ V}$ If lower than the above value, C31 (P0705) is indicated.	GP switch, wiring/coupler connection, gearshift cam, etc.
P0705			
C32/C33	Fuel injector	CKP sensor (pickup coil) signal is produced, but fuel injector signal is interrupted 4 times or more continuously. In this case, the code C32 (P0201) or C33 (P0202) is indicated.	Fuel injector, wiring/coupler connection, power supply to the injector
P0201/P0202			

DTC No.		DETECTED ITEM	DETECTED FAILURE CONDITION	CHECK FOR
C40 P0505	H	ISC valve	ISC valve motor current is higher than specified value.	ISC valve circuit shorted to BATT or ground circuit open
	L		ISC valve motor circuit is open.	ISC valve circuit open or BATT circuit open
P0506			Idle speed is lower than the desired idle speed.	W/Y or Lg wire open or ground circuit open Air circuit clogged ISC valve is fixed
P0507			Idle speed is higher than the desired idle speed.	W/Y or Dgr wire open or shorted or ground circuit open ISC valve is fixed ISC valve hose connection
C41		Fuel pump relay	No voltage is applied to the fuel pump, although fuel pump relay is turned ON, or voltage is applied to fuel pump although fuel pump relay is turned OFF.	Fuel pump relay, lead wire/coupler connection, power source to fuel pump relay and fuel injectors
P0230				
P0230	H		Voltage is applied to fuel pump although fuel pump relay is turned OFF.	Fuel pump relay switch circuit shorted to power source Fuel pump relay (switch side)
	L		No voltage is applied to the fuel pump, although fuel pump relay is turned ON.	Fuel pump relay circuit open or short Fuel pump relay (coil side).
C42 P1650		Ignition switch	Ignition switch signal is not input to ECM.	Ignition switch, lead wire/coupler
C44/C64		HO2 sensor (E-02, 19, 24)	HO2 sensor output voltage is not input to ECM during engine operation and running condition. (Sensor voltage < 0.45 V) In other than the above value, C44 (P0156/0130) is indicated.	HO2 sensor circuit open or shorted to ground
P0156/P0130				
C44/C64			The Heater can not operate so that heater operation voltage is not supply to the oxygen heater circuit, C44 (P0161/0135) is indicated.	HO2 sensor lead wire/coupler connection Battery voltage supply to the HO2 sensor
P0161/P0135				



DTC No.	DETECTED ITEM	DETECTED FAILURE CONDITION	CHECK FOR	
C46	Exhaust control valve actuator	EXCVA position sensor produces following voltage. $0.1\text{ V} \leq \text{sensor voltage} < 4.9\text{ V}$ In other than the above range, C46 (P1657) is indicated. When no actuator control signal is supplied from the ECM, communication signal does not reach ECM or operation voltage does not reach EXCVA motor, C46 (P1658) is indicated. EXCVA can not operate.	EXCVA, EXCVA lead wire/coupler	
P1657				
P1657		H	EXCVA position sensor voltage is higher than specified value.	EXCVA position sensor circuit shorted to VCC or ground circuit open
		L	EXCVA position sensor voltage is lower than specified value.	EXCVA position sensor circuit open or shorted to ground or VCC circuit open
P1658		When no actuator control signal is supplied from the ECM, communication signal does not reach ECM or operation voltage does not reach EXCVA motor, C46 (P1658) is indicated. EXCVA motor can not operate.	EXCVA, EXCVA motor lead wire/coupler	
C49/C61 P1768/P1656	PAIR control solenoid valve	PAIR control solenoid valve voltage is not input to ECM.	PAIR control solenoid valve, lead wire/coupler	
C60 P0480	Cooling fan relay	Cooling fan relay signal is not input to ECM.	Cooling fan relay, lead wire/coupler connection	

## “C12” (P0335) CKP SENSOR CIRCUIT MALFUNCTION

DETECTED CONDITION	POSSIBLE CAUSE
The signal does not reach ECM for 3 sec. or more, after receiving the starter signal.	<ul style="list-style-type: none"> <li>• Metal particles or foreign material being stuck on the CKP sensor and rotor tip.</li> <li>• CKP sensor circuit open or short.</li> <li>• CKP sensor malfunction.</li> <li>• ECM malfunction.</li> </ul>

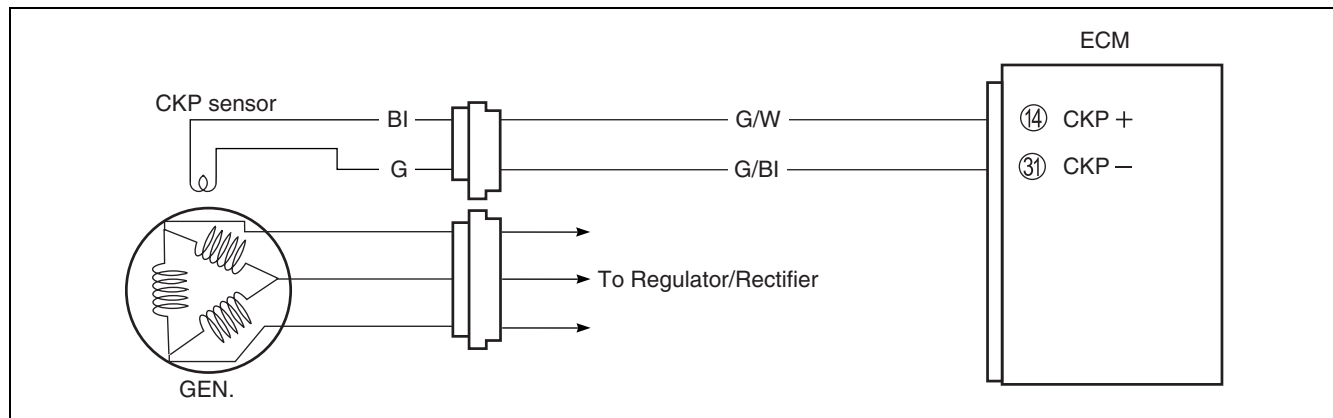

### INSPECTION

#### Step 1

- 1) Remove the right frame side cover. (☞ 9-5)
- 2) Remove the left frame lower side cover. (☞ 3-6)
- 3) Turn the ignition switch OFF.
- 4) Check the CKP sensor coupler for loose or poor contacts.  
If OK, then measure the CKP sensor resistance.

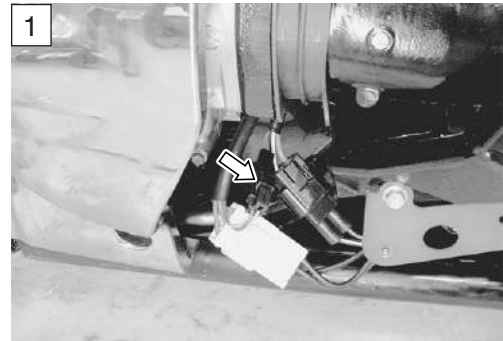

- 5) Disconnect the CKP sensor coupler and measure the resistance.

**DATA** CKP sensor resistance: 190 – 290 Ω  
(Green – Blue)

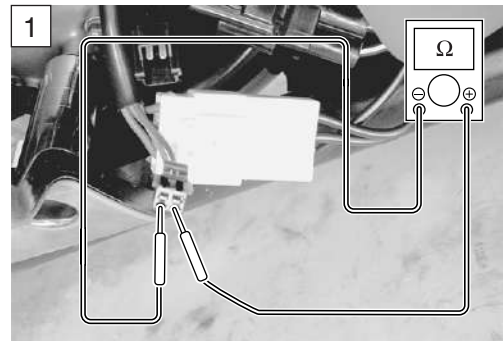

6) If OK, then check the continuity between each terminal and ground.

**DATA** CKP sensor continuity:  $\infty \Omega$  (Infinity)  
 (Blue – Ground)  
 (Green – Ground)

**TOOL** 09900-25008: Multi-circuit tester set

**Tester knob indication: Resistance ( $\Omega$ )**

Are the resistance and continuity OK?

YES	Go to step 2.
NO	Replace the CKP sensor with a new one.

7) After repairing the trouble, clear the DTC using SDS tool.  
 (☞ 5-26)

**Step 2**

- 1) Crank the engine a few seconds with the starter motor, and measure the CKP sensor peak voltage at the coupler.
- 2) Repeat the above test procedure a few times and measure the highest peak voltage.

**DATA** CKP sensor peak voltage: 1.5 V and more  
 (⊖ Green – ⊕ Blue)

① Peak volt adaptor

**TOOL** 09900-25008: Multi-circuit tester set

**Tester knob indication: Voltage (V)**

Is the voltage OK?

YES	<ul style="list-style-type: none"> <li>• G/W or G/BI wire open or shorted to ground.</li> <li>• Loose or poor contacts on the CKP sensor coupler or ECM coupler (terminal ⑭ or ⑳).</li> <li>• If wire and connection are OK, intermittent trouble or faulty ECM.</li> <li>• Recheck each terminal and wire harness for open circuit and poor connection.</li> <li>• Replace the ECM with a known good one, and inspect it again.</li> </ul>
NO	<ul style="list-style-type: none"> <li>• Inspect that metal particles or foreign material stuck on the CKP sensor and rotor tip.</li> <li>• If there are no metal particles and foreign material, then replace the CKP sensor with a new one.</li> </ul>

3) After repairing the trouble, clear the DTC using SDS tool.  
 (☞ 5-26)

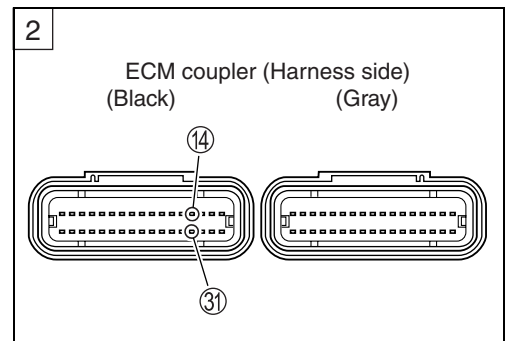
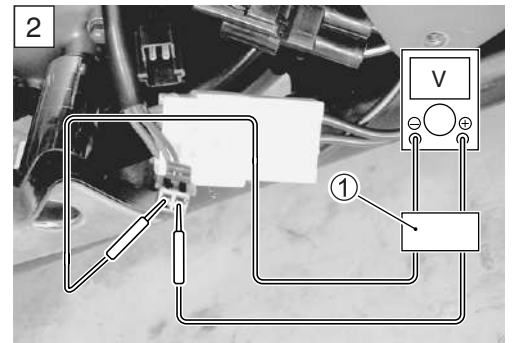
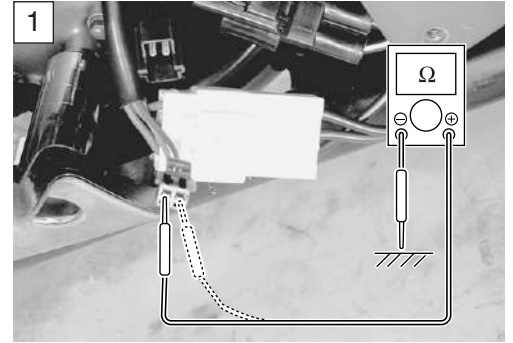

## “C13” (P1750-H/L) or “C17” (P0105-H/L) IAP SENSOR CIRCUIT MALFUNCTION

	DETECTED CONDITION	POSSIBLE CAUSE
C13/C17	IAP sensor voltage is not within the following range. $0.5 \text{ V} \leq \text{Sensor voltage} < 4.85 \text{ V}$ <b>NOTE:</b> <i>Note that atmospheric pressure varies depending on weather conditions as well as altitude.</i> <i>Take that into consideration when inspecting voltage.</i>	<ul style="list-style-type: none"> <li>• Clogged vacuum passage between throttle body and IAP sensor.</li> <li>• Air being drawn from vacuum passage between throttle body and IAP sensor.</li> <li>• IAP sensor circuit open or shorted to ground.</li> <li>• IAP sensor malfunction.</li> <li>• ECM malfunction.</li> </ul>
P1750/ P0105		
P1750/ P0105	H	Sensor voltage is higher than specified value.
	L	Sensor voltage is lower than specified value.

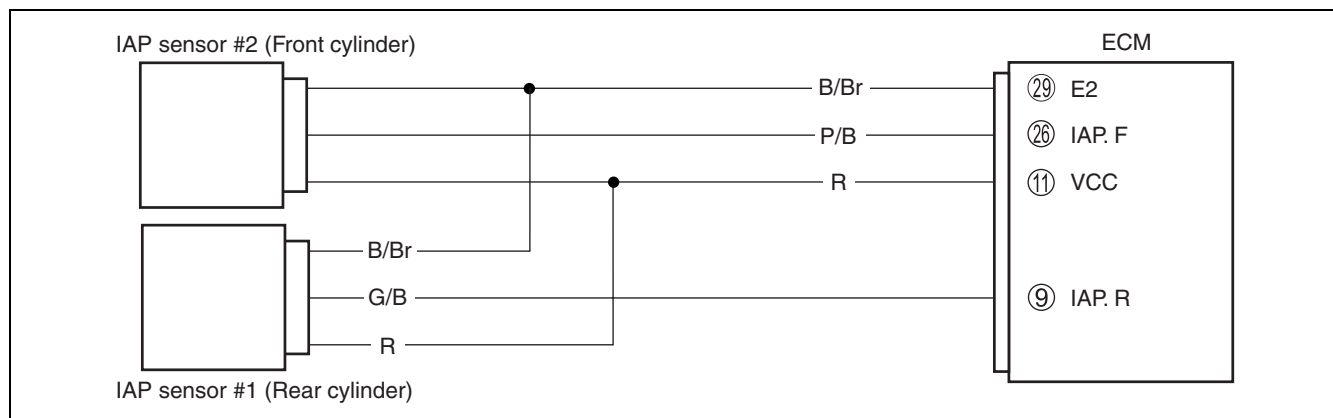

### INSPECTION

#### Step 1

(When indicating C13 for IAP sensor #2)

(When indicating C17 for IAP sensor #1)

- 1) Remove the fuel tank. (☞ 6-3)
- 2) Turn the ignition switch OFF.
- 3) Check the IAP sensor coupler (#2 ① or #1 ②) for loose or poor contacts.

If OK, then measure the IAP sensor input voltage.

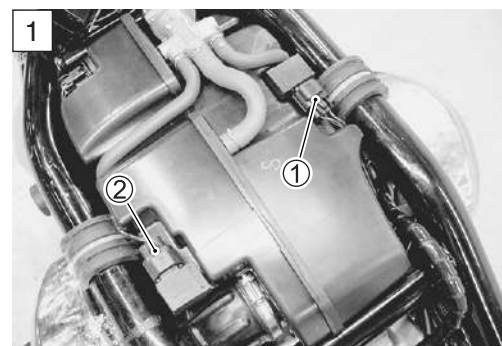

- 4) Disconnect the IAP sensor coupler.
- 5) Turn the ignition switch ON.
- 6) Measure the voltage at the Red wire ③ and ground.
- 7) If OK, then measure the voltage at the Red wire ③ and B/Br wire ④.

**DATA** IAP sensor input voltage: 4.5 – 5.5 V  
 (+ Red – (-) Ground)  
 (+ Red – (-) B/Br)

**TOOL** 09900-25008: Multi-circuit tester set

**Tester knob indication: Voltage (V)**

Is the voltage OK?

YES	Go to Step 2.
NO	<ul style="list-style-type: none"> <li>• Loose or poor contacts on the ECM coupler (terminal ①① or ②⑨).</li> <li>• Open or short circuit in the Red wire or B/Br wire.</li> </ul>

- 8) After repairing the trouble, clear the DTC using SDS tool. (☞ 5-26)

**Step 2**

- 1) Connect the IAP sensor coupler.
- 2) Reinstall the fuel tank and lift up fuel tank.
- 3) Insert the needle pointed probes to the lead wire coupler.
- 4) Start the engine at idle speed and measure the IAP sensor output voltage at the wire side coupler.  
 (#2: between P/B and B/Br wires)  
 (#1: between G/B and B/Br wires)

**DATA** IAP sensor output voltage:  
 Approx. 2.6 V at idle speed  
 (#2: (+) P/B – (-) B/Br)  
 (#1: (+) G/B – (-) B/Br)

**TOOL** 09900-25008: Multi-circuit tester set  
 09900-25009: Needle pointed probe set

**Tester knob indication: Voltage (V)**

Is the voltage OK?

YES	Go to Step 3.
NO	<ul style="list-style-type: none"> <li>• Check the vacuum hose for crack or damage.</li> <li>• Open or short circuit in the P/B wire. (#2)</li> <li>• Open or short circuit in the G/B wire. (#1)</li> <li>• If vacuum hose and wire are OK, replace the IAP sensor with a new one.</li> </ul>

- 5) After repairing the trouble, clear the DTC using SDS tool. (☞ 5-26)

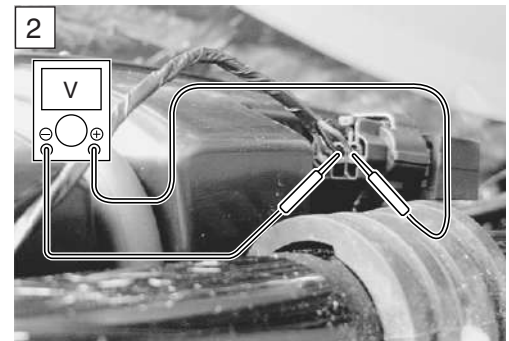
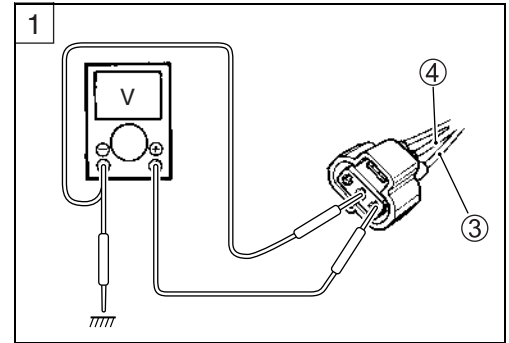

**Step 3**

- 1) Turn the ignition switch OFF.
- 2) Remove the IAP sensor. (↗ 6-13)
- 3) Connect the vacuum pump gauge to the vacuum port of the IAP sensor.
- 4) Arrange 3 new 1.5 V batteries in series ① (check that total voltage is 4.5 – 5.0 V) and connect ⊖ terminal to the ground terminal ② and ⊕ terminal to the VCC terminal ③.
- 5) Check the voltage between Vout terminal ④ and ground ②. Also, check if voltage reduces when vacuum is applied up to 400 mmHg by using vacuum pump gauge. (↗ 5-40)

 **09917-47011: Vacuum pump gauge**  
**09900-25008: Multi-circuit tester set**

 **Tester knob indication: Voltage (---)**

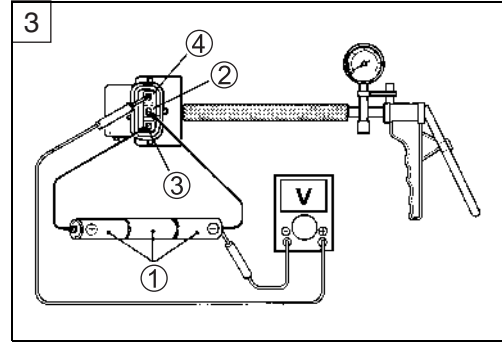

Is the voltage OK?

YES	<ul style="list-style-type: none"> <li>• Red, P/B or B/Br wire open or shorted to ground, or poor ⑪, ⑳ or ㉑ connection (#2)</li> <li>• G/B, Red or B/Br wire open or shorted to ground, or poor ⑨, ⑪ or ㉑ connection (#1)</li> <li>• If wire and connection are OK, intermittent trouble or faulty ECM.</li> <li>• Recheck each terminal and wire harness for open circuit and poor connection.</li> <li>• Replace the ECM with a known good one, and inspect it again.</li> </ul>
NO	If check result is not satisfactory, replace the IAP sensor with a new one.

- 6) After repairing the trouble, clear the DTC using SDS tool. (↗ 5-26)

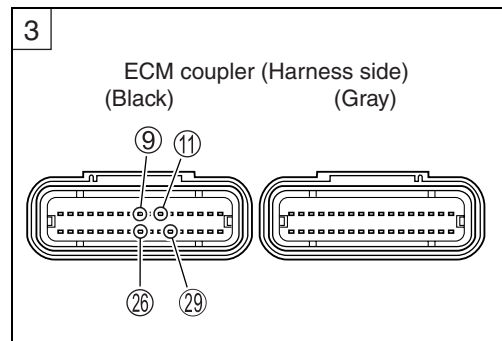



**Step 1****(When indicating P1750-H for IAP sensor #2)****(When indicating P0105-H for IAP sensor #1)**

- 1) Turn the ignition switch OFF.
- 2) Remove the fuel tank. (☞ 6-3)
- 3) Check the IAP sensor coupler for loose or poor contacts.  
If OK, then check the IAP sensor lead wire continuity.

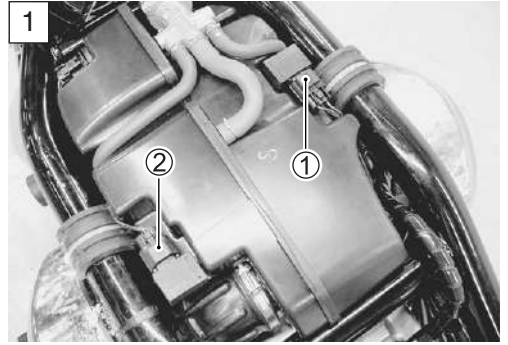

- 4) Disconnect the IAP sensor coupler.
- 5) Check the continuity between Red wire (A) and P/B (#2 ①) or G/B (#1 ②) wire (B).  
If the sound is not heard from the tester, the circuit condition is OK.

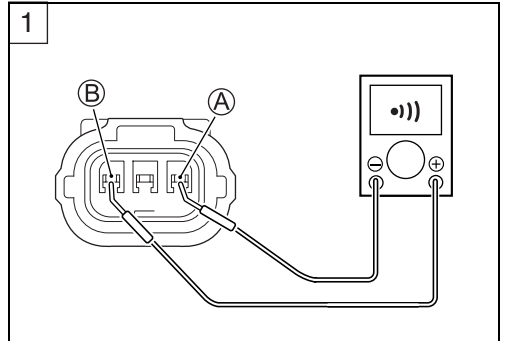

- 6) Remove the left frame lower side cover. (☞ 3-6)
- 7) Remove the ECM bracket and disconnect the ECM coupler.

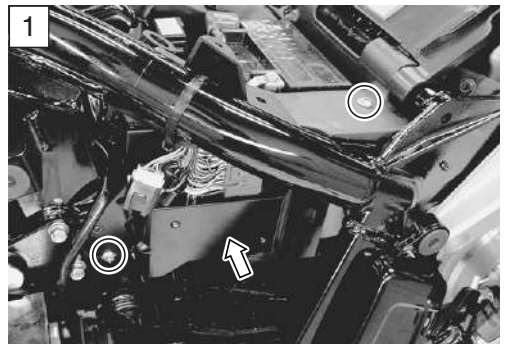

- 8) Check the continuity between P/B wire ② and terminal ⑨ (#2), and G/B wire ① and terminal ⑳ (#1).
- 9) If OK, then check the continuity between B/Br wire ③ (#1 and #2) and terminal ㉑.

**CAUTION**

When using the multi-circuit tester, do not strongly touch the terminal of the ECM coupler with a needle pointed tester probe to prevent the terminal damage or terminal bend.

**DATA** IAPS lead wire continuity: Continuity (•••)

- TOOL** 09900-25008: Multi-circuit tester set
- 09900-25009: Needle pointed probe set

**Tester knob indication: Continuity test (•••)**

Is the continuity OK?

YES	Go to Step 2.
NO	G/B or P/B wire shorted to VCC, or B/Br wire open.

- 10) After repairing the trouble, clear the DTC using SDS tool. (☞ 5-26)

**Step 1**

(When indicating P1750-L for IAP sensor #2)

(When indicating P0105-L for IAP sensor #1)

- 1) Turn the ignition switch OFF.
- 2) Remove the fuel tank. (☞ 6-3)
- 3) Check the IAP sensor coupler for loose or poor contacts. If OK, then check the IAP sensor lead wire continuity.
- 4) Disconnect the IAP sensor coupler.
- 5) Check the continuity between P/B (#2 ①) or G/B (#1 ②) wire ② and ground.
- 6) Also, check the continuity between P/B or G/B wire ② and B/Br wire ③. If the sound is not heard from the tester, the circuit condition is OK.

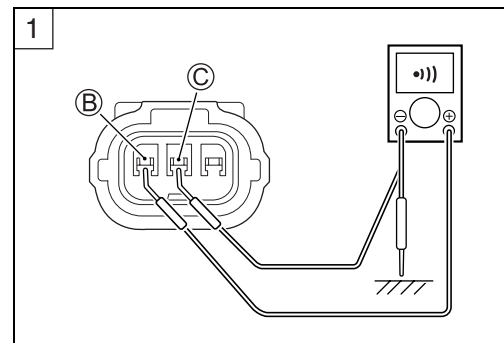
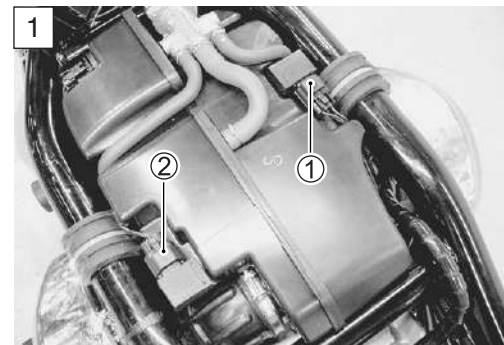
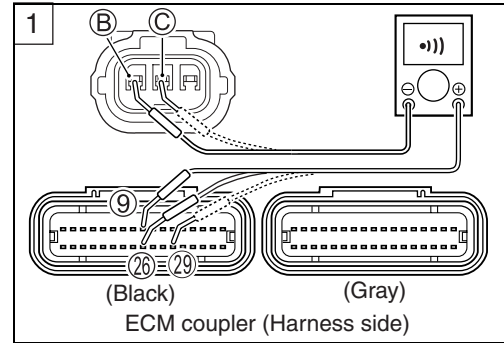

- 7) Disconnect the ECM coupler. (☞ 5-37)
- 8) Check the continuity between Red wires ① (#1 and #2) and terminal ⑩.
- 9) Also, check the continuity between P/B wire ⑨ and terminal ⑨, and G/B wire ② and terminal ⑫.

**CAUTION**

**When using the multi-circuit tester, do not strongly touch the terminal of the ECM coupler with a needle pointed tester probe to prevent the terminal damage or terminal bend.**

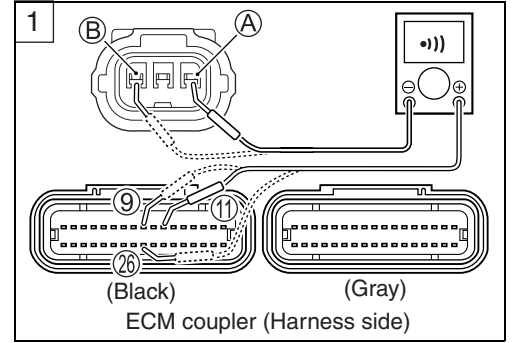

**DATA** IAPS lead wire continuity: Continuity (•••)

**TOOL** 09900-25008: Multi-circuit tester set  
09900-25009: Needle pointed probe set

**Tester knob indication: Continuity test (•••)**

Is the continuity OK?

YES	Go to Step 1 (☞ 5-34) and go to Step 2.
NO	Red wire and P/B or G/B wire open, or P/B and G/B wire shorted to ground

- 10) After repairing the trouble, clear the DTC using SDS tool. (☞ 5-26)

**Step 2**

- 1) Connect the IAP sensor coupler and ECM coupler.
- 2) Reinstall the fuel tank and lift up the fuel tank.
- 3) Insert the needle pointed probes to the lead wire coupler.
- 4) Start the engine at idle speed and measure the IAP sensor output voltage at the wire side coupler.
  - (#2: between P/B and B/Br wires)
  - (#1: between G/B and B/Br wires)

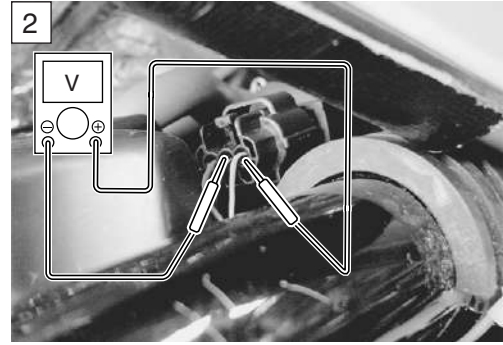
**DATA** IAP sensor output voltage:

**Approx. 1.4 – 3.8 V at idle speed**

**(#2: ⊕ P/B – ⊖ B/Br)**

**(#1: ⊕ G/B – ⊖ B/Br)**

- TOOL** 09900-25008: Multi-circuit tester set  
 09900-25009: Needle pointed probe set

**Tester knob indication: Voltage (V)**

Is the voltage OK?

YES	Go to Step 3.
NO	<ul style="list-style-type: none"> <li>• Check the vacuum hose for crack or damage.</li> <li>• Open or short circuit in the P/B wire. (#2)</li> <li>• Open or short circuit in the G/B wire. (#1)</li> <li>• If vacuum hose and wire are OK, replace the IAP sensor with a new one.</li> </ul>

- 5) After repairing the trouble, clear the DTC using SDS tool.  
 (☞ 5-26)

**Step 3** (☞ 5-36)

**Output voltage (VCC voltage 4.5 – 5.0 V, ambient temp. 20 – 30 °C, 68 – 86 °F)**

ALTITUDE (Reference)		ATMOSPHERIC PRESSURE		OUTPUT VOLTAGE
(ft)	(m)	(mmHg)	kPa	(V)
0	0	760	100	3.4 – 4.0
2 000	610	707	94	
2 001	611	707	94	3.0 – 3.7
5 000	1 524	634	85	
5 001	1 525	634	85	2.6 – 3.4
8 000	2 438	567	76	
8 001	2 439	567	76	2.4 – 3.1
10 000	3 048	526	70	

## “C14” (P0120-H/L) TP SENSOR CIRCUIT MALFUNCTION

DETECTED CONDITION		POSSIBLE CAUSE	
C14	Output voltage is not within the following range. Difference between actual throttle opening and opening calculated by ECM is larger than specified value. $0.2\text{ V} \leq \text{Sensor voltage} < 4.8\text{ V}$	<ul style="list-style-type: none"> <li>• TP sensor maladjusted</li> <li>• TP sensor circuit open or short</li> <li>• TP sensor malfunction</li> <li>• ECM malfunction</li> </ul>	
P0120			
P0120			
	H	Sensor voltage is higher than specified value.	<ul style="list-style-type: none"> <li>• TP sensor circuit shorted to VCC or ground circuit open</li> </ul>
	L	Sensor voltage is lower than specified value.	

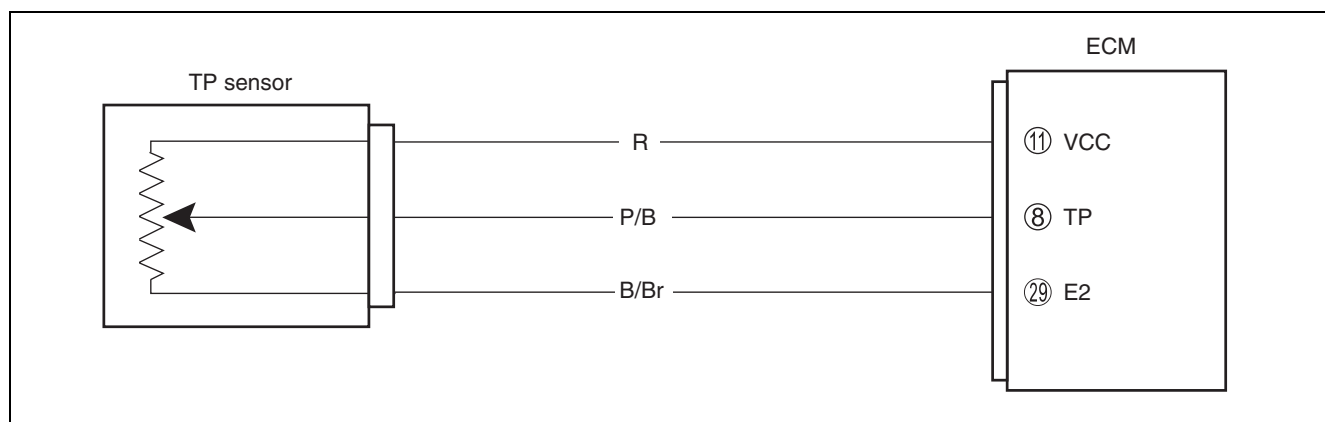

### INSPECTION

#### Step 1 (When indicating C14:)

- 1) Turn the ignition switch OFF.
- 2) Remove the fuel tank. (6-3)
- 3) Check the TP sensor coupler for loose or poor contacts.  
If OK, then measure the TP sensor input voltage.
- 4) Disconnect the TP sensor coupler.
- 5) Turn the ignition switch ON.
- 6) Measure the voltage at the Red wire (B) and ground.
- 7) If OK, then measure the voltage at the Red wire (B) and B/Br wire (C).

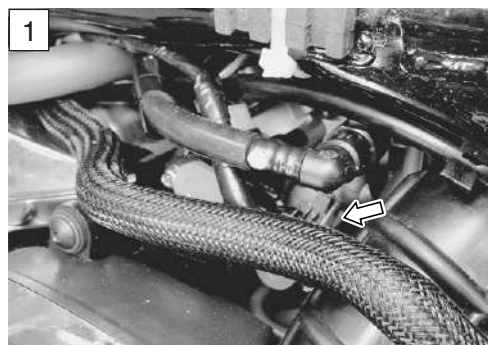

**DATA** TP sensor input voltage: 4.5 – 5.5 V

(+ Red – – Ground)

(+ Red – – B/Br)

**TOOL** 09900-25008: Multi-circuit tester set

**Tester knob indication: Voltage (V)**

Is the voltage OK?

YES	Go to Step 2.
NO	<ul style="list-style-type: none"> <li>• Loose or poor contacts on the ECM coupler (terminal 11 or 29).</li> <li>• Open or short circuit in the Red wire or B/Br wire.</li> </ul>

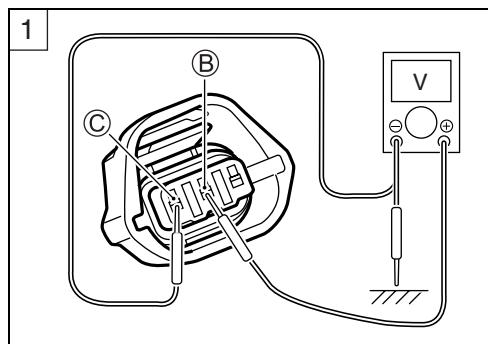

**Step 1 (When indicating P0120-H:)**

- 1) Turn the ignition switch OFF.
- 2) Remove the fuel tank. (☞ 6-3)
- 3) Check the TP sensor coupler for loose or poor contacts.  
If OK, then check the TP sensor lead wire continuity.

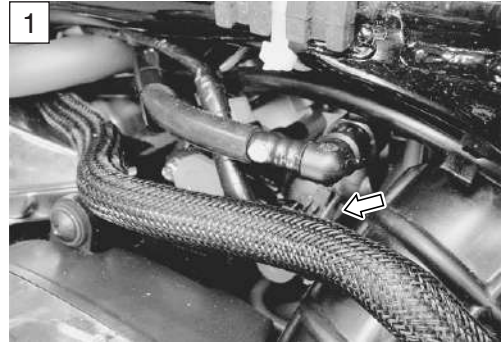

- 4) Disconnect the TP sensor coupler.
- 5) Check the continuity between P/B wire (A) and Red wire (B).  
If the sound is not heard from the tester, the circuit condition is OK.

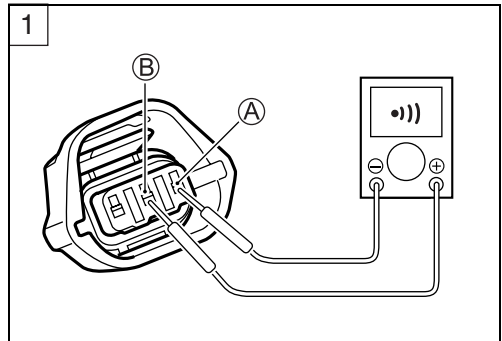

- 6) Disconnect the ECM coupler. (☞ 5-37)
- 7) Check the continuity between P/B wire (A) and terminal (8).
- 8) Also, check the continuity between B/Br wire (C) and terminal (29).

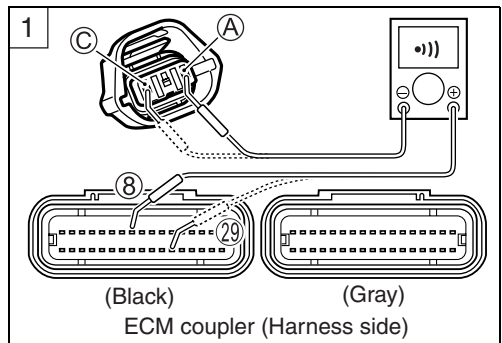

**CAUTION**

When using the multi-circuit tester, do not strongly touch the terminal of the ECM coupler with a needle pointed tester probe to prevent the terminal damage or terminal bend.

**DATA** TPS lead wire continuity: Continuity (•))

- TOOL** 09900-25008: Multi-circuit tester set
- 09900-25009: Needle pointed probe set

**Tester knob indication: Continuity test (•))**

Is the continuity OK?

YES	Go to Step 2.
NO	P/B wire shorted to VCC, or B/Br wire open

- 9) After repairing the trouble, clear the DTC using SDS tool. (☞ 5-26)



**Step 1 (When indicating P0120-L:)**

- 1) Turn the ignition switch OFF.
- 2) Remove the fuel tank. (↖ 6-3)
- 3) Check the TP sensor coupler for loose or poor contacts.  
If OK, then check the TP sensor lead wire continuity.

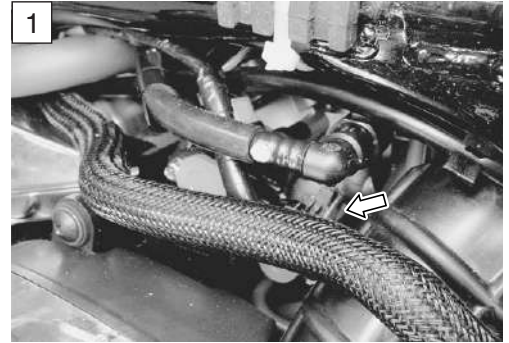

- 4) Disconnect the TP sensor coupler.
- 5) Check the continuity between P/B wire (A) and ground.
- 6) Also, check the continuity between P/B wire (A) and B/Br wire (C). If the sound is not heard from the tester, the circuit condition is OK.

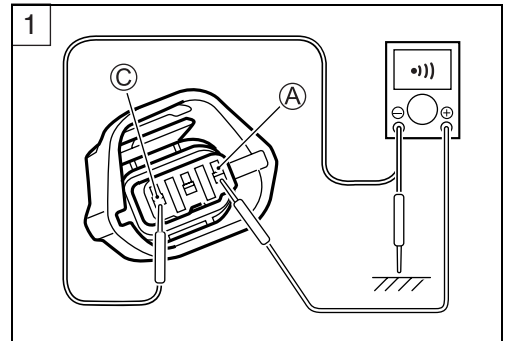

- 7) Disconnect the ECM coupler. (↖ 5-37)
- 8) Check the continuity between P/B wire (A) and terminal (8).
- 9) Also, check the continuity between Red wire (B) and terminal (1).

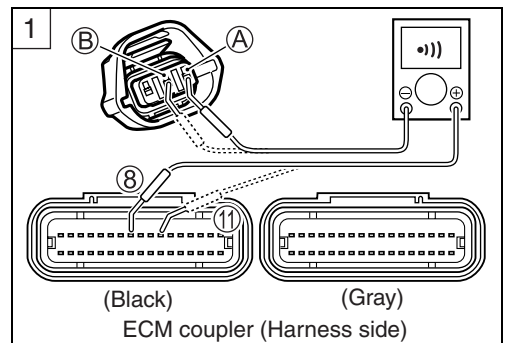

**CAUTION**

**When using the multi-circuit tester, do not strongly touch the terminal of the ECM coupler with a needle pointed tester probe to prevent the terminal damage or terminal bend.**

**DATA** TPS lead wire continuity: Continuity (•••)

**TOOL** 09900-25008: Multi-circuit tester set  
09900-25009: Needle pointed probe set

**Tester knob indication: Continuity test (•••)**

Is the continuity OK?

YES	Go to Step 1 (↖ 5-41) and go to Step 2.
NO	Red wire or P/B wire open, or P/B wire shorted to ground

- 10) After repairing the trouble, clear the DTC using SDS tool. (↖ 5-26)

**Step 2**

- 1) Turn the ignition switch OFF.
- 2) Disconnect the TP sensor coupler and ECM coupler.
- 3) Install the test harness to the TP sensor.
- 4) Check the continuity between terminal ① and ground.



**DATA** TP sensor continuity:  $\infty \Omega$  (Infinity)  
(Terminal ① – Ground)

- 5) If OK, then measure the TP sensor resistance at the test harness terminals (between terminal ① and terminal ②).
- 6) Turn the throttle grip and measure the resistance.

**DATA** TP sensor resistance  
Throttle valve is closed: Approx. 1.1 k $\Omega$   
Throttle valve is opened: Approx. 4.3 k $\Omega$

- 7) If OK, then measure the TP sensor resistance at the test harness terminals (between terminal ③ and terminal ④).

**DATA** TP sensor resistance: Approx. 5.0 k $\Omega$   
(Terminal ③ – Terminal ④)

-  09900-25008: Multi-circuit tester set
- 09900-28630: TPS test wire harness
-  Tester knob indication: Resistance ( $\Omega$ )

Are the continuity and resistance OK?

YES	Go to Step 3.
NO	<ul style="list-style-type: none"> <li>• Reset the TP sensor position correctly.</li> <li>• Replace the TP sensor with a new one.</li> </ul>

- 8) After repairing the trouble, clear the DTC using SDS tool.  
( 5-26)

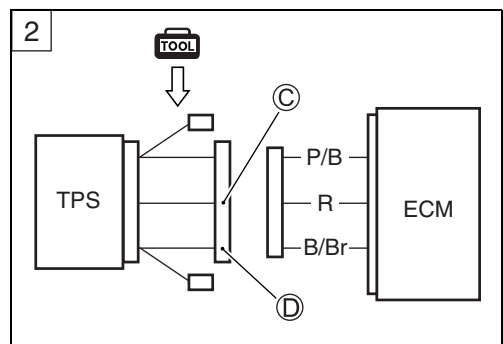
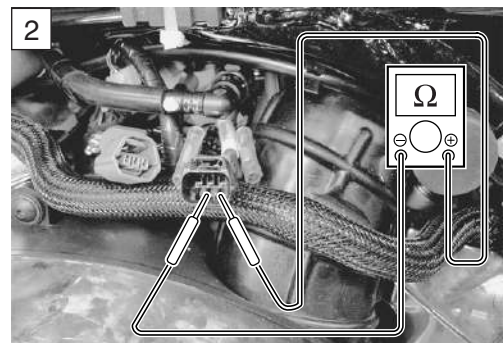
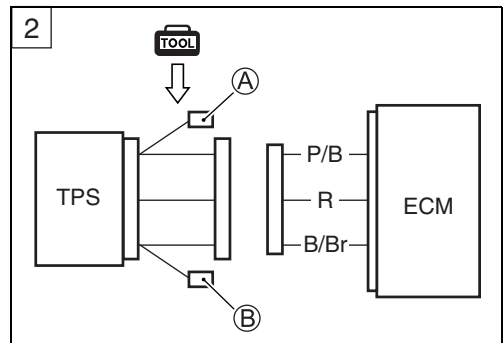
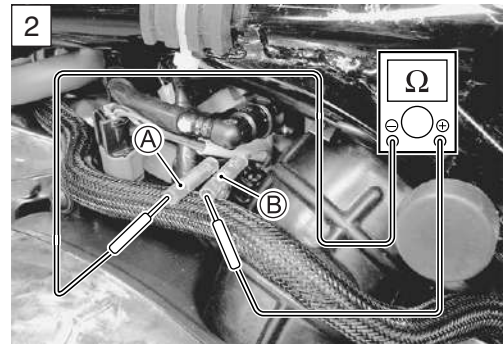
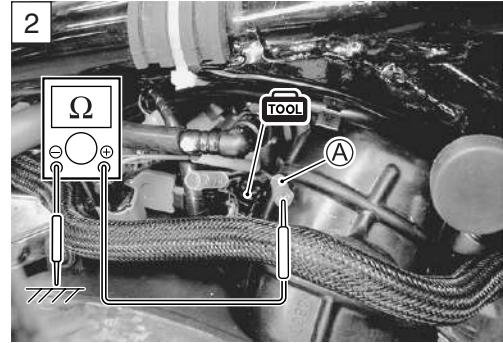

**Step 3**

- 1) Connect the TP sensor coupler ① to the test harness.
- 2) Turn the ignition switch ON.
- 3) Measure the TP sensor output voltage at the coupler (between ⊕ P/B and ⊖ B/Br) by turning the throttle grip.

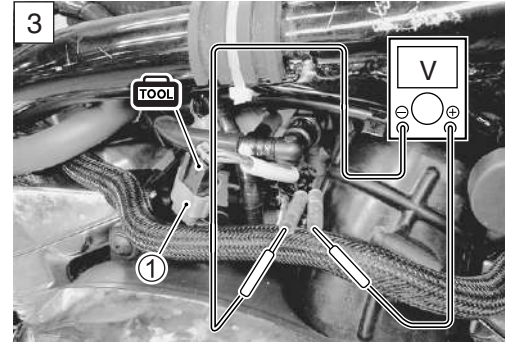

**DATA** TP sensor output voltage

Throttle valve is closed: **Approx. 1.1 V**

Throttle valve is opened: **Approx. 4.3 V**

**TOOL** 09900-25008: Multi-circuit tester set

**V** Tester knob indication: Voltage (---)

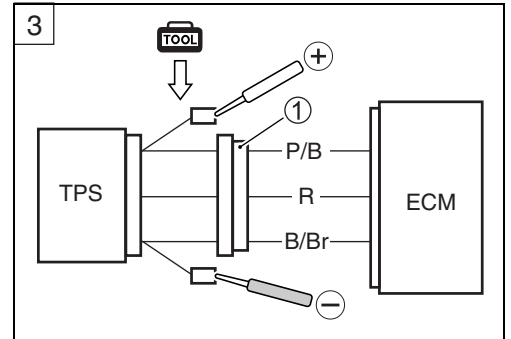

Is the voltage OK?

YES	<ul style="list-style-type: none"> <li>• P/B, Red or B/Br wire open or shorted to ground, or poor ⑧, ⑪ or ⑲ connection</li> <li>• If wire and connection are OK, intermittent trouble or faulty ECM.</li> <li>• Recheck each terminal and wire harness for open circuit and poor connection.</li> <li>• Replace the ECM with a known good one, and inspect it again.</li> </ul>
NO	If check result is not satisfactory, replace TP sensor with a new one.

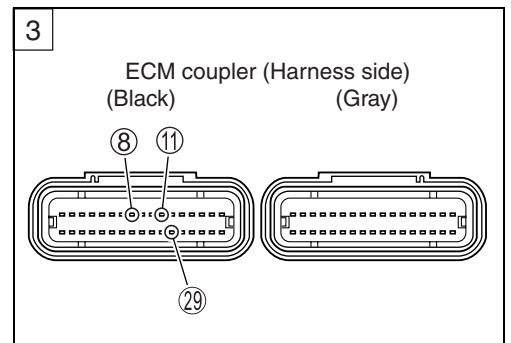

- 4) After repairing the trouble, clear the DTC using SDS tool.

(☞ 5-26)

**“C15” (P0115-H/L) ECT SENSOR CIRCUIT MALFUNCTION**

DETECTED CONDITION		POSSIBLE CAUSE
C15	Output voltage is not within the following range.	<ul style="list-style-type: none"> <li>• ECT sensor circuit open or short</li> <li>• ECT sensor malfunction</li> <li>• ECM malfunction</li> <li>• ECT sensor circuit open or ground circuit open</li> <li>• ECT sensor circuit shorted to ground</li> </ul>
P0115	$0.15 \text{ V} \leq \text{Sensor voltage} < 4.85 \text{ V}$	
P0115	Sensor voltage is higher than specified value.	
	H	
	L	

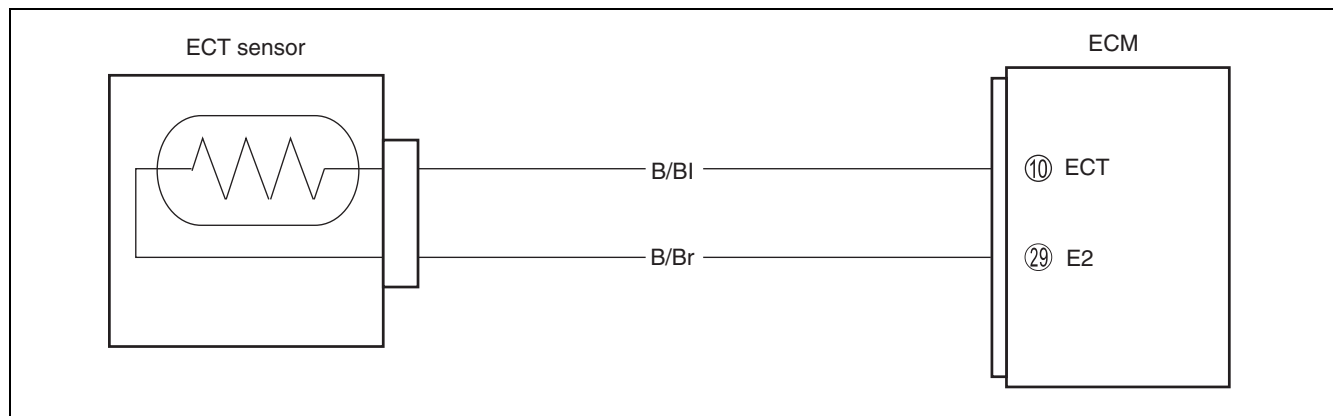
**INSPECTION****Step 1 (When indicating C15:)**

- 1) Turn the ignition switch OFF.
- 2) Remove the right air cleaner box. (☞ 6-13)
- 3) Check the ECT sensor coupler for loose or poor contacts.  
If OK, then measure the ECT sensor voltage at the wire side coupler.
- 4) Disconnect the coupler and turn the ignition switch ON.
- 5) Measure the voltage between B/BI wire terminal ① and ground.
- 6) If OK, then measure the voltage between B/BI wire terminal ① and B/Br wire terminal ②.

**DATA** ECT sensor voltage: 4.5 – 5.5 V  
 (+ B/BI – (–) Ground)  
 (+ B/BI – (–) B/Br)

**TOOL** 09900-25008: Multi-circuit tester set

**Tester knob indication: Voltage (V)**

Is the voltage OK?

YES	Go to Step 2.
NO	<ul style="list-style-type: none"> <li>• Loose or poor contacts on the ECM coupler (terminal ⑩ or ⑲).</li> <li>• Open or short circuit in the B/BI wire or B/Br wire</li> </ul>

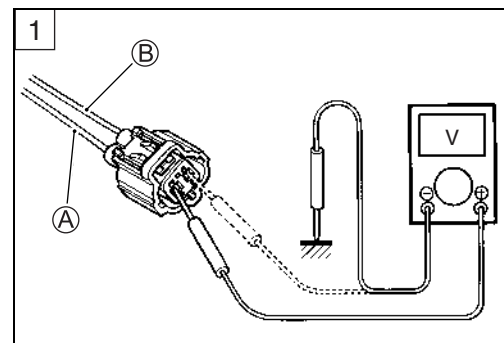
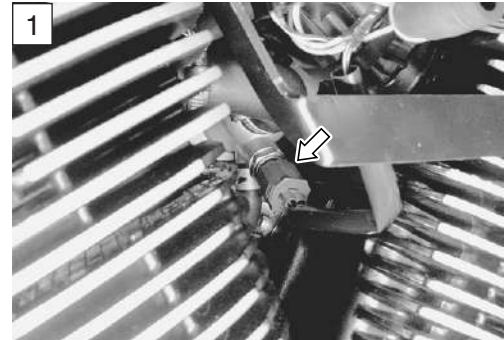

**Step 1 (When indicating P0115-H:)**

- 1) Turn the ignition switch OFF.
- 2) Remove the right air cleaner box. (☞ 6-13)
- 3) Check the ECT sensor coupler for loose or poor contacts.  
If OK, then check the ECT sensor lead wire continuity.

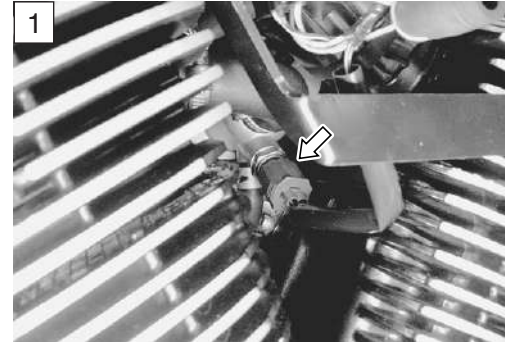

- 4) Disconnect the ECT sensor coupler and ECM coupler. (☞ 5-37)
- 5) Check the continuity between B/BI wire (A) and terminal 10.
- 6) Also, check the continuity between B/Br wire (B) and terminal 29.

**CAUTION**

**When using the multi-circuit tester, do not strongly touch the terminal of the ECM coupler with a needle pointed tester probe to prevent the terminal damage or terminal bend.**

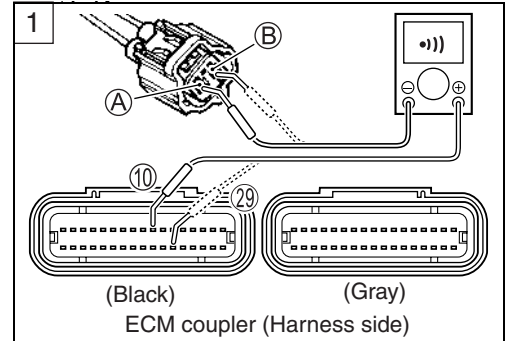

**DATA** ECTS lead wire continuity: Continuity (•••)

**TOOL** 09900-25008: Multi-circuit tester set  
09900-25009: Needle pointed probe set

**Tester knob indication: Continuity test (•••)**

Is the continuity OK?

YES	Go to Step 2.
NO	B/BI or B/Br wire open

- 7) After repairing the trouble, clear the DTC using SDS tool. (☞ 5-26)

**Step 1 (When indicating P0115-L:)**

- 1) Turn the ignition switch OFF.
- 2) Remove the right air cleaner box. (☞ 6-13)
- 3) Check the ECT sensor coupler for loose or poor contacts.  
If OK, then measure the output voltage.

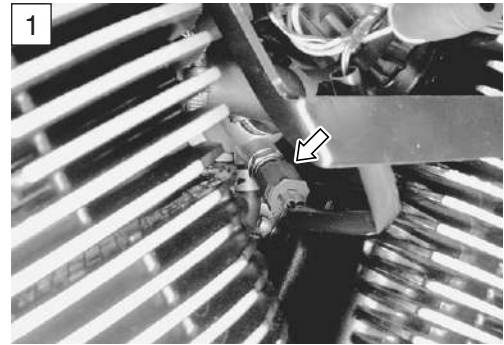

- 4) Disconnect the ECT sensor coupler.
- 5) Check the continuity between B/BI wire (A) and ground.  
If the sound is not heard from the tester, the circuit condition is OK.

**Tester knob indication: Continuity test (•••)**

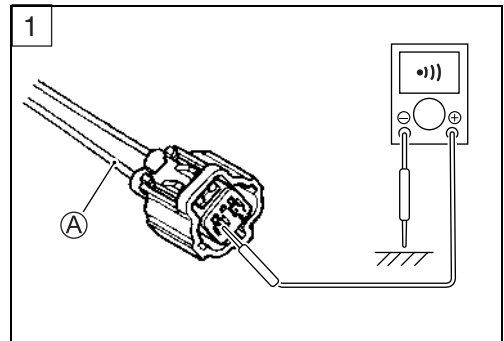

- 6) Connect the ECT sensor coupler and turn the ignition switch ON.
- 7) Measure the voltage between B/BI wire (A) and ground.

**DATA ECT sensor output voltage: 0.15 – 4.84 V**  
(+ B/BI – - Ground)

**09900-25008: Multi-circuit tester set**  
**09900-25009: Needle pointed probe set**

**Tester knob indication: Voltage (---)**

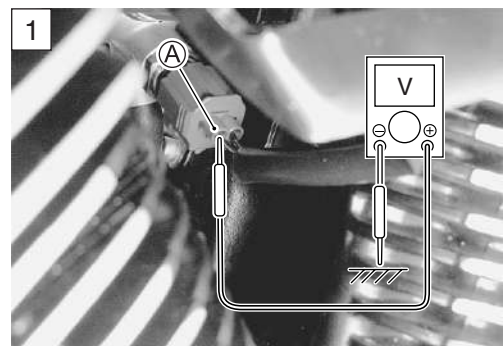

Are the continuity and voltage OK?

YES	Go to Step 2.
NO	<ul style="list-style-type: none"> <li>• B/BI wire shorted to ground</li> <li>• If wire is OK, go to Step 2.</li> </ul>

- 8) After repairing the trouble, clear the DTC using SDS tool.  
(☞ 5-26)



**Step 2**

- 1) Turn the ignition switch OFF.
- 2) Disconnect the ECT sensor coupler.
- 3) Measure the ECT sensor resistance.

**DATA** ECT sensor resistance:

**Approx. 2.45 kΩ at 20 °C (68 °F)**  
**(Terminal – Terminal)**

**TOOL** 09900-25008: Multi-circuit tester set

**Tester knob indication: Resistance (Ω)**

Refer to page 8-9 for details.

Is the resistance OK?

YES	<ul style="list-style-type: none"> <li>• B/Bl or B/Br wire open or shorted to ground, or poor ⑩ or ⑳ connection.</li> <li>• If wire and connection are OK, intermittent trouble or faulty ECM.</li> <li>• Recheck each terminal and wire harness for open circuit and poor connection.</li> <li>• Replace the ECM with a known good one, and inspect it again.</li> </ul>
NO	Replace the ECT sensor with a new one.

- 4) After repairing the trouble, clear the DTC using SDS tool.  
(☞ 5-26)

**DATA** ECT sensor specification

Engine Oil Temp	Resistance
20 °C (68 °F)	Approx. 2.45 kΩ
50 °C (122 °F)	Approx. 0.811 kΩ
80 °C (176 °F)	Approx. 0.318 kΩ
110 °C (230 °F)	Approx. 0.142 kΩ

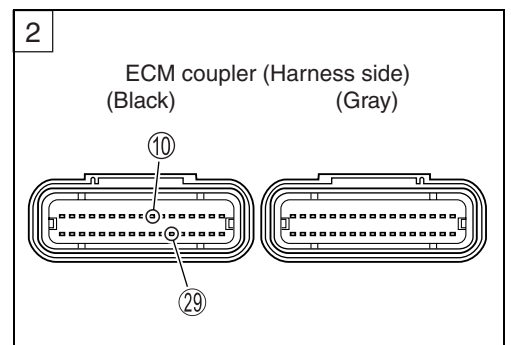
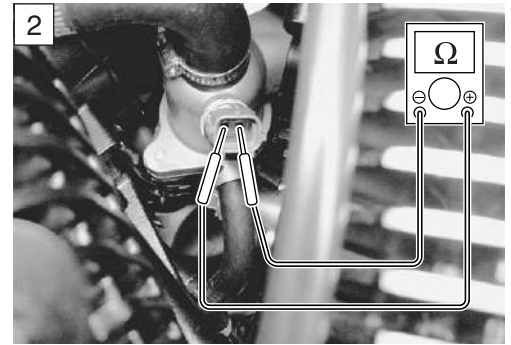

## “C21” (P0110-H/L) IAT SENSOR CIRCUIT MALFUNCTION

DETECTED CONDITION		POSSIBLE CAUSE
C21	Output voltage is not within the following range.	<ul style="list-style-type: none"> <li>IAT sensor circuit open or short</li> <li>IAT sensor malfunction</li> <li>ECM malfunction</li> <li>IAT sensor circuit open or ground circuit open</li> <li>IAT sensor circuit shorted to ground</li> </ul>
P0110	$0.15 \text{ V} \leq \text{Sensor voltage} < 4.85 \text{ V}$	
P0110	Sensor voltage is higher than specified value.	
	H	
	L	

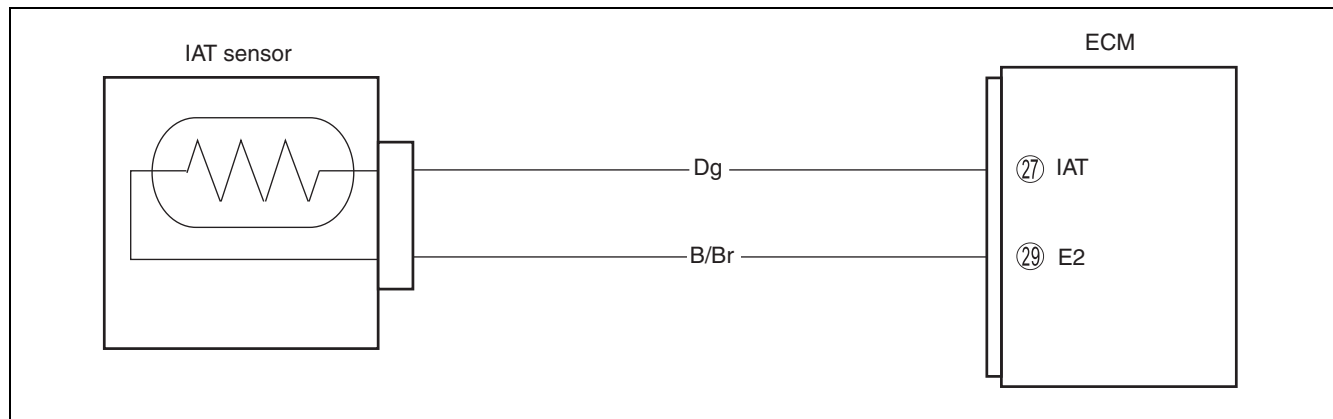

### INSPECTION

#### Step 1 (When indicating C21:)

- Turn the ignition switch OFF.
- Remove the fuel tank. (☞ 6-3)
- Check the IAT sensor coupler for loose or poor contacts.  
If OK, then measure the IAT sensor voltage at the wire side coupler.
- Disconnect the coupler and turn the ignition switch ON.



- Measure the voltage between Dg wire terminal (A) and ground.
- If OK, then measure the voltage between Dg wire terminal (A) and B/Br wire terminal (B).

**DATA** IAT sensor input voltage: 4.5 – 5.5 V  
 (+ Dg – (–) Ground)  
 (+ Dg – (–) B/Br)

**TOOL** 09900-25008: Multi-circuit tester set

**Tester knob indication: Voltage (V)**

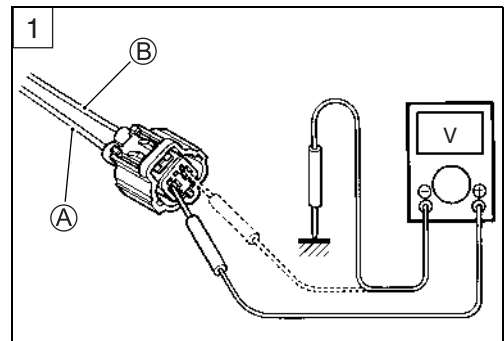

Is the voltage OK?

YES	Go to Step 2.
NO	<ul style="list-style-type: none"> <li>Loose or poor contacts on the ECM coupler (terminal 27 or 29)</li> <li>Open or short circuit in the Dg wire or B/Br wire</li> </ul>

**Step 1 (When indicating P0110-H:)**

- 1) Turn the ignition switch OFF.
- 2) Remove the fuel tank. (☞ 6-3)
- 3) Check the IAT sensor coupler for loose or poor contacts.  
If OK, then check the IAT sensor lead wire continuity.



- 4) Disconnect the IAT sensor coupler and ECM coupler. (☞ 5-37)
- 5) Check the continuity between Dg wire (A) and terminal 27.
- 6) Also, check the continuity between B/Br wire (B) and terminal 29.

**CAUTION**

**When using the multi-circuit tester, do not strongly touch the terminal of the ECM coupler with a needle pointed tester probe to prevent the terminal damage or terminal bend.**

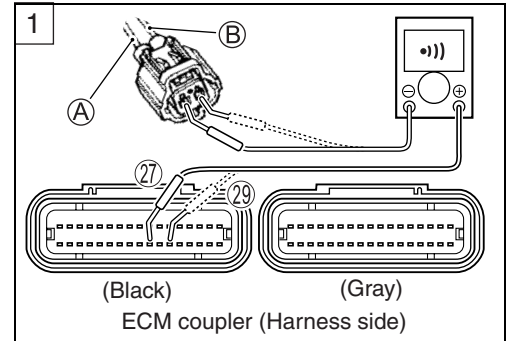

**DATA** IATS lead wire continuity: Continuity (•••)

**TOOL** 09900-25008: Multi-circuit tester set  
09900-25009: Needle pointed probe set

**Tester knob indication: Continuity test (•••)**

Is the continuity OK?

YES	Go to Step 2.
NO	Dg wire or B/Br wire open

- 7) After repairing the trouble, clear the DTC using SDS tool. (☞ 5-26)

**Step 1 (When indicating P0110-L:)**

- 1) Turn the ignition switch OFF.
- 2) Remove the fuel tank. (📄 6-3)
- 3) Check the IAT sensor coupler for loose or poor contacts.  
If OK, then check the IAT sensor lead wire continuity.



- 4) Disconnect the IAT sensor coupler.
- 5) Check the continuity between Dg wire (A) and ground. If the sound is not heard from the tester, the circuit condition is OK.

 **Tester knob indication: Continuity test (•••)**

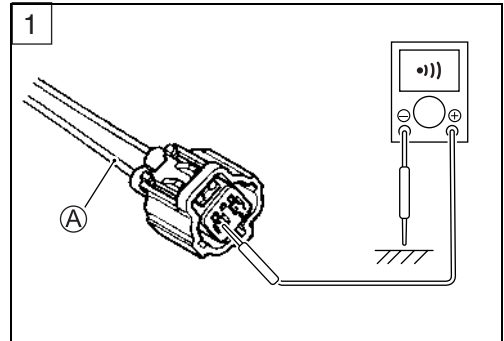

- 6) Connect the IAT sensor coupler and turn the ignition switch ON.
- 7) Measure the voltage between Dg wire (A) and ground.

**DATA** IAT sensor output voltage: 0.15 – 4.84 V  
(+ Dg – - Ground)

 **09900-25008: Multi-circuit tester set**  
**09900-25009: Needle pointed probe set**

 **Tester knob indication: Voltage (V)**

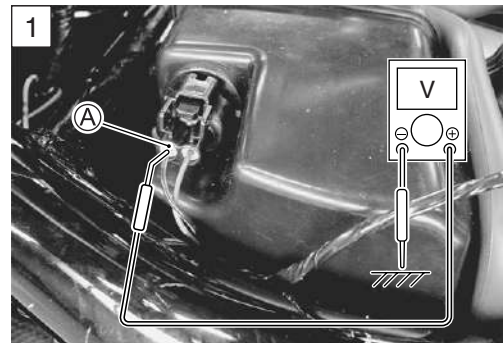

Are the continuity and voltage OK?

YES	Go to Step 2.
NO	<ul style="list-style-type: none"> <li>• Dg wire shorted to ground</li> <li>• If wire is OK, go to Step 2.</li> </ul>

- 8) After repairing the trouble, clear the DTC using SDS tool. (📄 5-26)

**Step 2**

- 1) Turn the ignition switch OFF.
- 2) Measure the IAT sensor resistance.

**DATA** IAT sensor resistance: Approx. 2.45 kΩ at 20 °C (68 °F)  
(Terminal – Terminal)

**TOOL** 09900-25008: Multi-circuit tester set

**Tester knob indication: Resistance (Ω)**

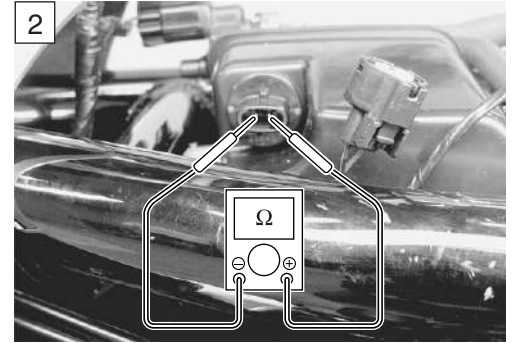

Is the resistance OK?

YES	<ul style="list-style-type: none"> <li>• Dg or B/Br wire open or shorted to ground, or poor ⑳ or ㉑ connection</li> <li>• If wire and connection are OK, intermittent trouble or faulty ECM.</li> <li>• Recheck each terminal and wire harness for open circuit and poor connection.</li> <li>• Replace the ECM with a known good one, and inspect it again.</li> </ul>
NO	Replace the IAT sensor with a new one.

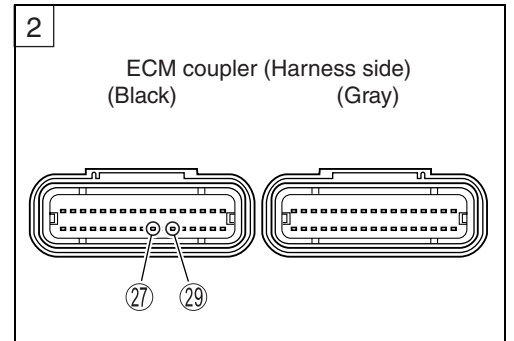

**DATA** IAT sensor specification

Intake Air Temp	Resistance
20 °C (68 °F)	Approx. 2.45 kΩ
80 °C (176 °F)	Approx. 0.322 kΩ
120 °C (248 °F)	Approx. 0.117 kΩ

**NOTE:**

IAT sensor resistance measurement method is the same way as that of the ECT sensor. Refer to page 8-9 for details.

## “C23” (P1651-H/L) TO SENSOR CIRCUIT MALFUNCTION

DETECTED CONDITION		POSSIBLE CAUSE
C23	The sensor voltage should be the following for 2 sec. and more, after ignition switch is turned ON. $0.2 \text{ V} \leq \text{Sensor voltage} < 4.8 \text{ V}$	<ul style="list-style-type: none"> <li>• TO sensor circuit open or short</li> <li>• TO sensor malfunction</li> <li>• ECM malfunction</li> </ul>
P1651		
P1651	H	<ul style="list-style-type: none"> <li>• TO sensor circuit shorted to VCC or ground circuit open</li> <li>• TO sensor circuit open or shorted to ground or VCC circuit open</li> </ul>
	L	

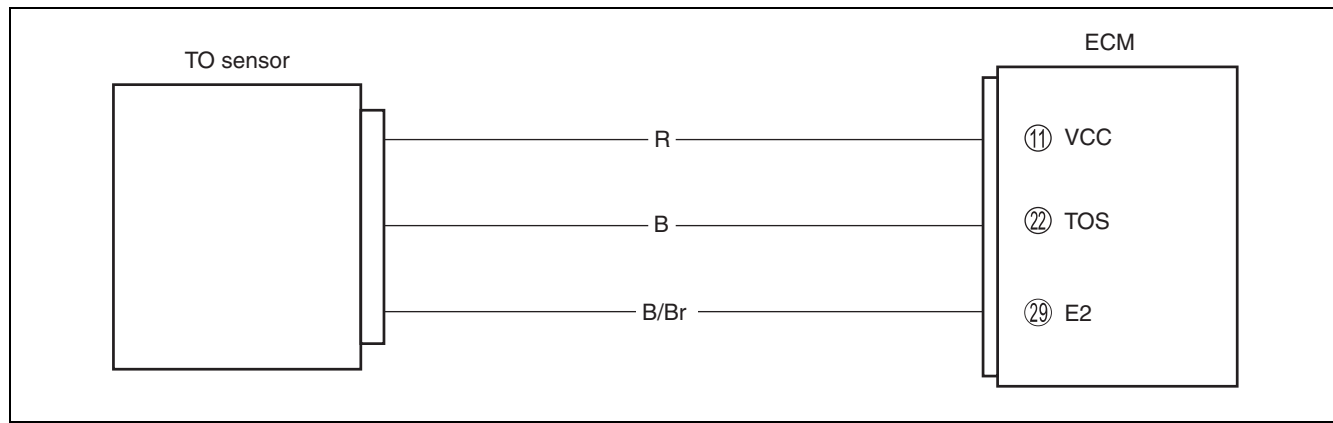

### INSPECTION

#### Step 1 (When indicating C23:)

- 1) Turn the ignition switch OFF.
- 2) Remove the fuel tank. (See 6-3)
- 3) Check the TO sensor coupler for loose or poor contacts.  
If OK, then measure the TO sensor resistance.
- 4) Disconnect the TO sensor coupler.

- 5) Measure the resistance between terminal (A) and terminal (C).

**DATA** TO sensor resistance: 16.5 – 22.3 kΩ  
(Terminal (A) – Terminal (C))

**TOOL** 09900-25008: Multi-circuit tester set

**Tester knob indication: Resistance (Ω)**

Is the resistance OK?

YES	Go to Step 2.
NO	Replace the TO sensor with a new one.





**Step 1 (When indicating P1651-H:)**

- 1) Turn the ignition switch OFF.
- 2) Remove the fuel tank. (☞ 6-3)
- 3) Check the TO sensor coupler for loose or poor contacts.  
If OK, then check the TO sensor lead wire continuity.



- 4) Disconnect the TO sensor coupler.
- 5) Check the continuity between Red wire (A) and Black wire (B).  
If the sound is not heard from the tester, the circuit condition is OK.

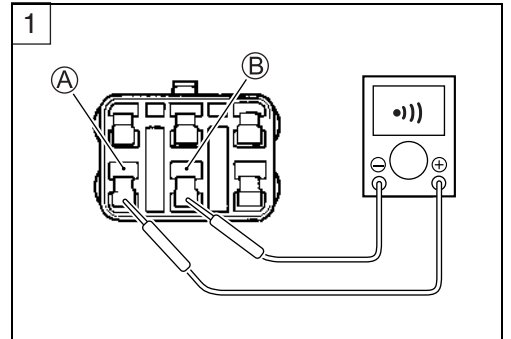

- 6) Disconnect the ECM coupler. (☞ 5-37)
- 7) Check the continuity between Black wire (B) and terminal 22.
- 8) Also, check the continuity between B/Br wire (C) and terminal 29.

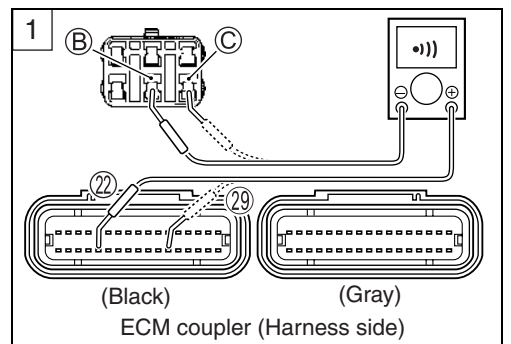

**CAUTION**

**When using the multi-circuit tester, do not strongly touch the terminal of the ECM coupler with a needle pointed tester probe to prevent the terminal damage or terminal bend.**

**DATA** TOS lead wire continuity: Continuity (•••)

**TOOL** 09900-25008: Multi-circuit tester set  
09900-25009: Needle pointed probe set

**Tester knob indication: Continuity test (•••)**

Is the continuity OK?

YES	Go to Step 2.
NO	Black wire shorted to VCC, or B/Br wire open.

- 9) After repairing the trouble, clear the DTC using SDS tool.  
(☞ 5-26)

**Step 1 (When indicating P1651-L:)**

- 1) Turn the ignition switch OFF.
- 2) Remove the fuel tank. (☞ 6-3)
- 3) Check the TO sensor coupler for loose or poor contacts.  
If OK, then check the TO sensor lead wire continuity.

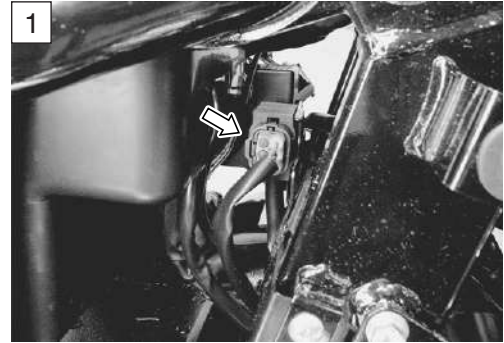

- 4) Disconnect the TO sensor coupler.
- 5) Check the continuity between Black wire (B) and ground.
- 6) Also, check the continuity between Black wire (B) and B/Br wire (C). If the sound is not heard from the tester, the circuit condition is OK.

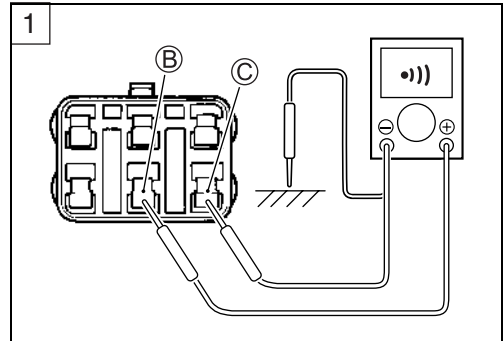

- 7) Disconnect the ECM coupler. (☞ 5-37)
- 8) Check the continuity between Red wire (A) and terminal 11.
- 9) Also, then check the continuity between Black wire (B) and terminal 22.

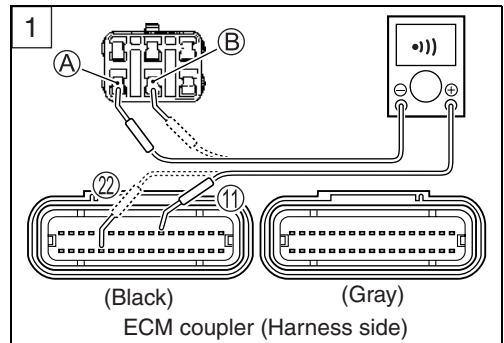

**CAUTION**

When using the multi-circuit tester, do not strongly touch the terminal of the ECM coupler with a needle pointed tester probe to prevent the terminal damage or terminal bend.

**DATA** TOS lead wire continuity: Continuity (•••)

**TOOL** 09900-25008: Multi-circuit tester set  
09900-25009: Needle pointed probe set

**Tester knob indication: Continuity test (•••)**

Is the continuity OK?

YES	Go to Step 2.
NO	Red or Black wire open, or Black wire shorted to ground.

- 10) After repairing the trouble, clear the DTC using SDS tool. (☞ 5-26)

**Step 2**

- 1) Connect the TO sensor coupler and ECM coupler.
- 2) Insert the needle pointed probes to the lead wire coupler.
- 3) Turn the ignition switch ON.
- 4) Measure the voltage at the wire side coupler between Black and B/Br wires.

**DATA** TO sensor voltage (Normal): 0.4 – 1.4 V  
 (+ Black – - B/Br)

Also, measure the voltage when leaning the motorcycle.

- 5) Dismount the TO sensor from its bracket and measure the voltage when it is leaned 65° and more, left and right, from the horizontal level.

**DATA** TO sensor voltage (Leaning): 3.7 – 4.4 V  
 (+ Black – - B/Br)

- TOOL** 09900-25008: Multi-circuit tester set
- 09900-25009: Needle pointed probe set

**Tester knob indication: Voltage (V)**

Is the voltage OK?

YES	<ul style="list-style-type: none"> <li>• Red, Black or B/Br wire open or shorted to ground, or poor ①①, ②② or ②⑨ connection</li> <li>• If wire and connection are OK, intermittent trouble or faulty ECM.</li> <li>• Recheck each terminal and wire harness for open circuit and poor connection.</li> <li>• Replace the ECM with a known good one, and inspect it again.</li> </ul>
NO	<ul style="list-style-type: none"> <li>• Loose or poor contacts on the ECM coupler</li> <li>• Open or short circuit</li> <li>• Replace the TO sensor with a new one.</li> </ul>

- 6) After repairing the trouble, clear the DTC using SDS tool.  
 (☞ 5-26)

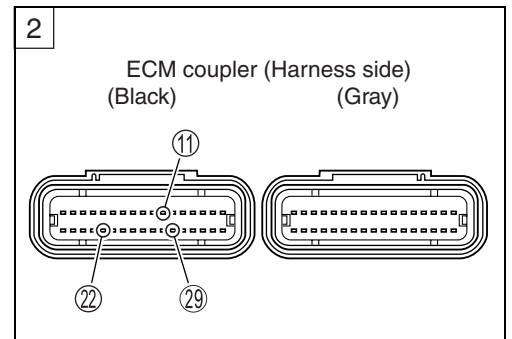
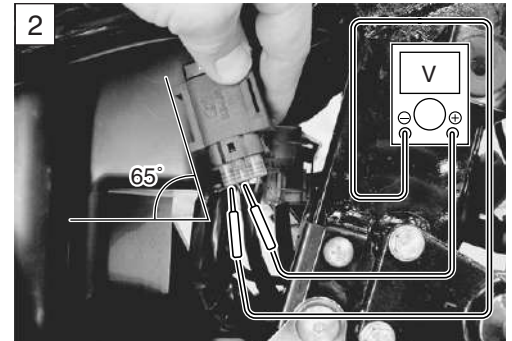
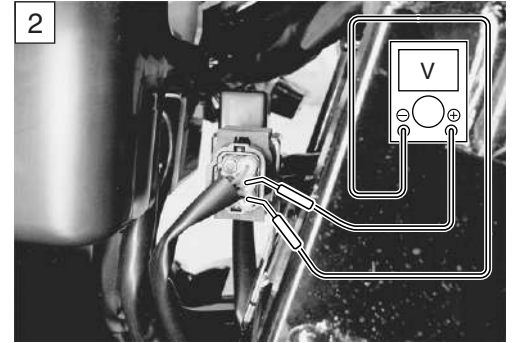

**“C24” (P0351), “C25” (P0352), “C26” (P0353) or “C27” (P0354) IGNITION SYSTEM MALFUNCTION**

(When indicating C24/P0351 and C26/P0353 for #1)

(When indicating C25/P0352 and C27/P0354 for #2)

\* Refer to the IGNITION SYSTEM for details. (☞ 10-22)

## “C28” (P1655) STV ACTUATOR CIRCUIT MALFUNCTION

DETECTED CONDITION	POSSIBLE CAUSE
The operation voltage does not reach the STVA. ECM does not receive communication signal from the STVA.	<ul style="list-style-type: none"> <li>• STVA malfunction</li> <li>• STVA circuit open or short</li> <li>• STVA motor malfunction</li> </ul>

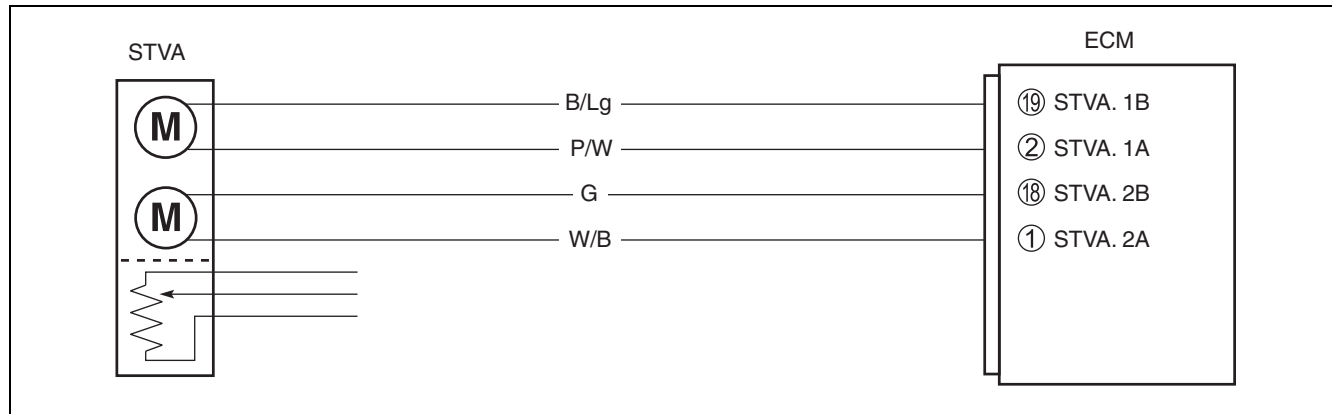

### INSPECTION

#### Step 1

- 1) Remove the air cleaner chamber. (📖 6-13)
- 2) Check the STVA lead wire coupler for loose or poor contacts.



- 3) Turn the ignition switch ON to check the STV operation.  
(STV operating order: Full open → 95% open)

Is the operating OK?

YES	Go to Step 2.
NO	<ul style="list-style-type: none"> <li>• Loose or poor contacts on the STVA coupler</li> <li>• Open or short circuit in the B/Lg, P/W, W/B or Green wires</li> <li>• If wire and connection are OK, go to Step 2.</li> </ul>

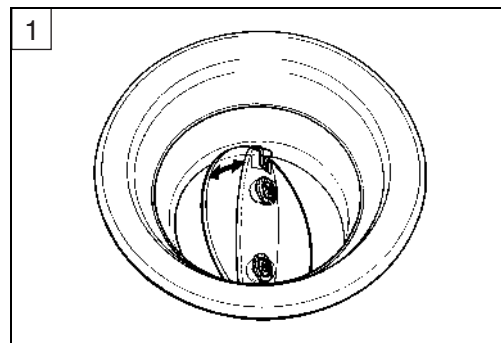

- 4) After repairing the trouble, clear the DTC using SDS tool.  
(📖 5-26)

**Step 2**

- 1) Turn the ignition switch OFF.
- 2) Disconnect the STVA lead wire coupler.
- 3) Check the continuity between each terminal and ground.

**DATA** STVA continuity:  $\infty \Omega$  (Infinity)  
(Terminal – Ground)

- 4) If OK, then measure the STVA resistance (between Black wire (A) and Pink wire (B)) and (between Green wire (C) and W/BI wire (D)).

**DATA** STVA resistance: Approx.  $7 \Omega$   
(B/Lg (A) – P/W (B))  
(Green (C) – W/B (D))

**TOOL** 09900-25008: Multi-circuit tester set

**Tester knob indication: Resistance ( $\Omega$ )**

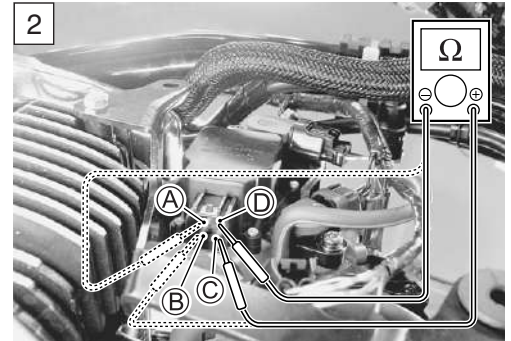
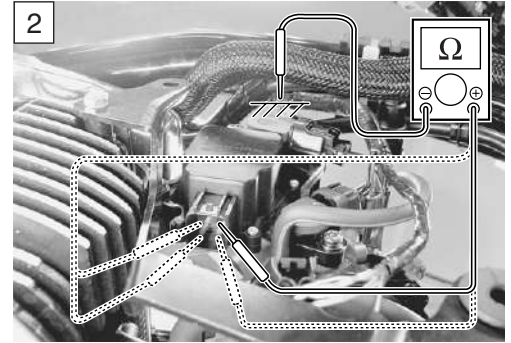

Is the resistance OK?

YES	<ul style="list-style-type: none"> <li>• W/B, P/W, Green and B/Lg wire open or shorted to ground, or poor ①, ②, ⑱ and ⑲ connection</li> <li>• If wire and connection are OK, intermittent trouble or faulty ECM.</li> <li>• Recheck each terminal and wire harness for open circuit and poor connection.</li> <li>• Replace the ECM with a known good one, and inspect it again.</li> </ul>
NO	<ul style="list-style-type: none"> <li>• Loose or poor contacts on the ECM coupler.</li> <li>• Replace the STVA with a new one.</li> </ul>

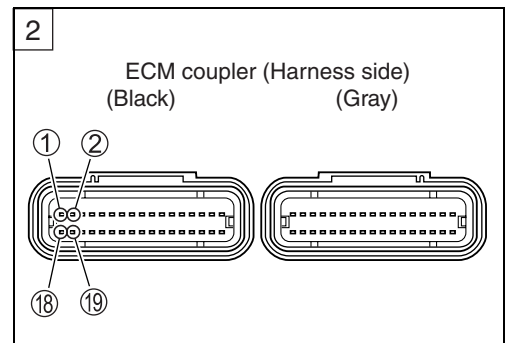

- 5) After repairing the trouble, clear the DTC using SDS tool.

(↖ 5-26)

**ACTIVE CONTROL INSPECTION**

- 1) Set up the SDS tool. (Refer to the SDS operation manual for further details.)
- 2) Turn the ignition switch ON.
- 3) Click “Secondary throttle operating control” ①.



- 4) Click each button ②.  
At this time, if an operation sound is heard from the STVA, the function is normal.

<input type="checkbox"/>	Secondary throttle actuator position sensor	98.0	%
<input type="checkbox"/>	Secondary throttle full opened	Full opened	
<input type="checkbox"/>	Secondary throttle full closed	Except full cls	
<input type="checkbox"/>	Starter signal	Off	
<input type="checkbox"/>	Battery voltage	0.0	V
<input type="checkbox"/>	Exhaust valve control select terminal	GND	

The image shows a software interface titled "Secondary throttle operating control". It has a "Spec" label and three buttons: "Off", "Full closed", and "Full opened". The "Full opened" button is highlighted in black and has a circled number "2" with an arrow pointing to it.



## “C29” (P1654-H/L) STP SENSOR CIRCUIT MALFUNCTION

DETECTED CONDITION		POSSIBLE CAUSE	
C29	Signal voltage is not within the following range. Difference between actual throttle opening and opening calculated by ECM is larger than specified value. $0.15\text{ V} \leq \text{Sensor voltage} < 4.85\text{ V}$	<ul style="list-style-type: none"> <li>• STP sensor maladjusted</li> <li>• STP sensor circuit open or short</li> <li>• STP sensor malfunction</li> <li>• ECM malfunction</li> </ul>	
P1654			
P1654			
	H	Sensor voltage is higher than specified value.	<ul style="list-style-type: none"> <li>• STP sensor circuit shorted to VCC or ground circuit open</li> <li>• STP sensor circuit open or shorted to ground or VCC circuit open</li> </ul>
	L	Sensor voltage is lower than specified value.	

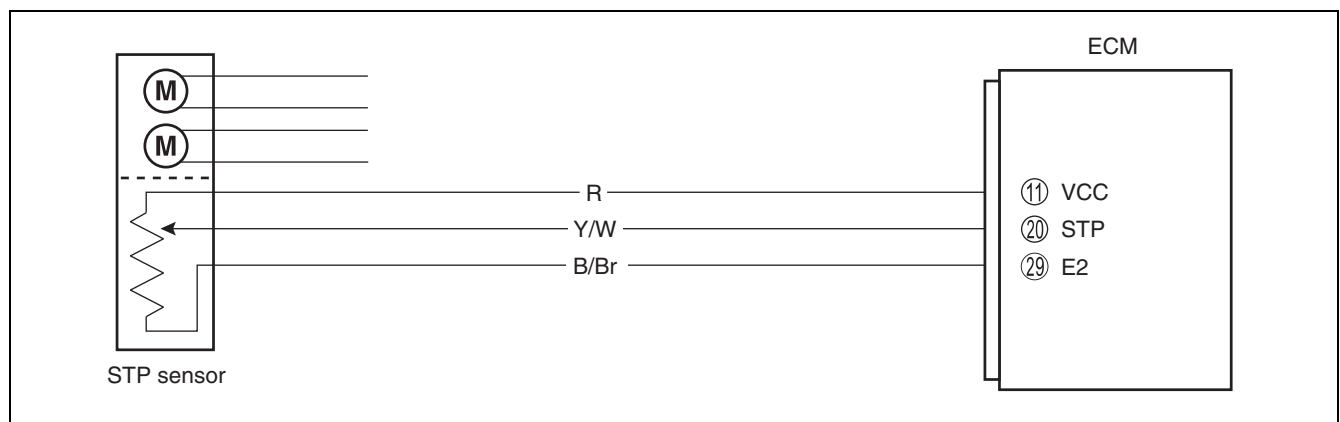

### INSPECTION

#### Step 1 (When indicating C29:)

- 1) Turn the ignition switch OFF.
- 2) Remove the right air cleaner box. (➡ 6-13)
- 3) Check the STP sensor coupler for loose or poor contacts.  
If OK, then measure the STP sensor input voltage.
- 4) Disconnect the STP sensor coupler. (Black)
- 5) Turn the ignition switch ON.
- 6) Measure the voltage at the Red wire ① and ground.
- 7) If OK, then measure the voltage at the Red wire ① and B/Br wire ②.



**DATA** STP sensor input voltage: 4.5 – 5.5 V

(+ Red – – Ground)

(+ Red – – B/Br)

**TOOL** 09900-25008: Multi-circuit tester set

**TESTER** Tester knob indication: Voltage (V)

Is the voltage OK?

YES	Go to Step 2.
NO	<ul style="list-style-type: none"> <li>• Loose or poor contacts on the ECM coupler (terminal ① or ②)</li> <li>• Open or short circuit in the Red wire or B/Br wire</li> </ul>

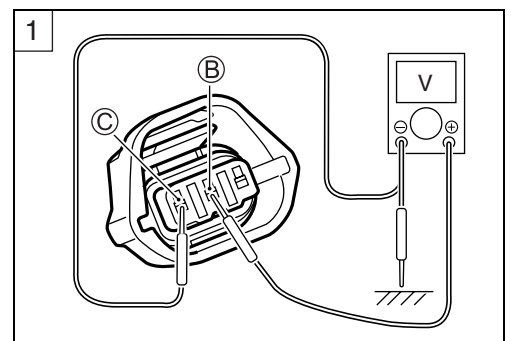

**Step 1 (When indicating P1654-H:)**

- 1) Turn the ignition switch OFF.
- 2) Remove the right air cleaner box. (☞ 6-13)
- 3) Check the STP sensor coupler for loose or poor contacts.  
If OK, then check the STP sensor lead wire continuity.  
STP sensor lead wire coupler: Black



- 4) Disconnect the STP sensor coupler.
- 5) Check the continuity between Y/W wire (A) and Red wire (B).  
If the sound is not heard from the tester, the circuit condition is OK.

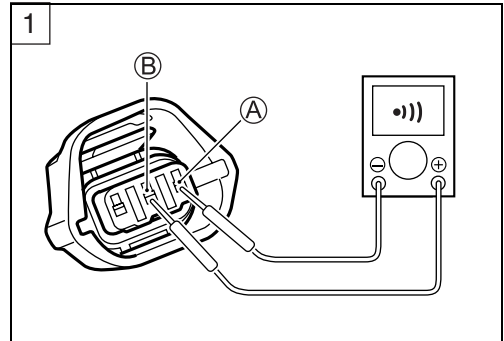

- 6) Disconnect the ECM coupler. (☞ 5-37)
- 7) Check the continuity between Y/W wire (A) and terminal (20).
- 8) Also, check the continuity between B/Br wire (C) and terminal (29).

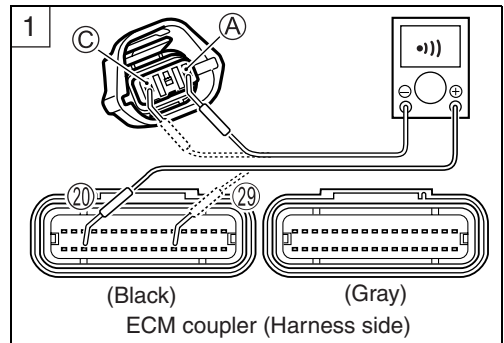

**CAUTION**

When using the multi-circuit tester, do not strongly touch the terminal of the ECM coupler with a needle pointed tester probe to prevent the terminal damage or terminal bend.

**DATA** STPS lead wire continuity: Continuity (•••)

**TOOL** 09900-25008: Multi-circuit tester set  
09900-25009: Needle probe set

**Tester knob indication: Continuity test (•••)**

Is the continuity OK?

YES	Go to Step 2.
NO	Y/W wire shorted to VCC, or B/Br wire open

- 9) After repairing the trouble, clear the DTC using SDS tool.  
(☞ 5-26)

**Step 1 (When indicating P1654-L:)**

- 1) Turn the ignition switch OFF.
- 2) Remove the right air cleaner box. (➡ 6-13)
- 3) Check the STP sensor coupler for loose or poor contacts.  
If OK, then check the STP sensor lead wire continuity.  
STP sensor lead wire coupler: Black

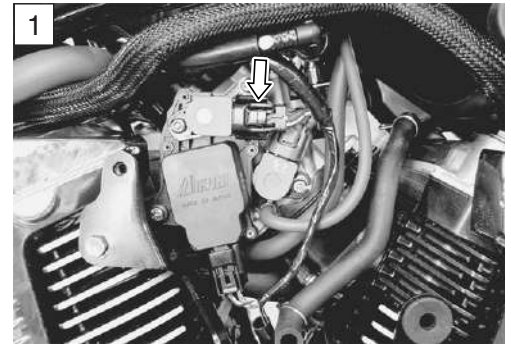

- 4) Disconnect the STP sensor coupler.
- 5) Check the continuity between Y/W wire (A) and ground.
- 6) Also, check the continuity between Y/W wire (A) and B/Br wire (C). If the sound is not heard from the tester, the circuit condition is OK.

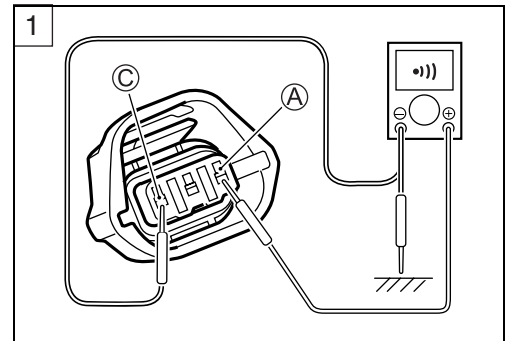

- 7) Disconnect the ECM coupler. (➡ 5-37)
- 8) Check the continuity between Y/W wire (A) and terminal (20).
- 9) Also, check the continuity between Red wire (B) and terminal (11).

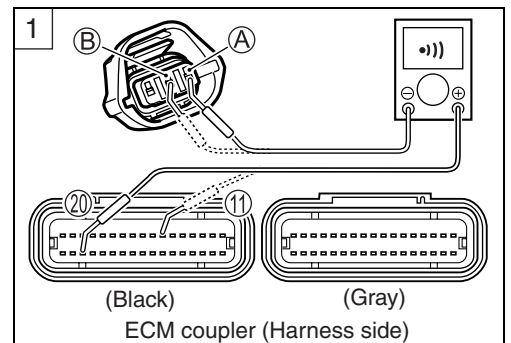

**CAUTION**

**When using the multi-circuit tester, do not strongly touch the terminal of the ECM coupler with a needle pointed tester probe to prevent the terminal damage or terminal bend.**

**DATA** STPS lead wire continuity: Continuity (••)

**TOOL** 09900-25008: Multi-circuit tester set  
09900-25009: Needle pointed probe set

**Tester knob indication: Continuity test (••)**

Is the continuity OK?

YES	Go to Step 1 (➡ 5-61) and go to Step 2.
NO	Red or Y/W wire open, or Y/W wire shorted to ground

- 10) After repairing the trouble, clear the DTC using SDS tool. (➡ 5-26)

**Step 2**

- 1) Turn the ignition switch OFF.
- 2) Remove the air cleaner chamber. (☞ 6-13)
- 3) Disconnect the STP sensor coupler.
- 4) Check the continuity between each terminal and ground.

**DATA** STP sensor continuity:  $\infty \Omega$  (Infinity)  
(Terminal – Ground)

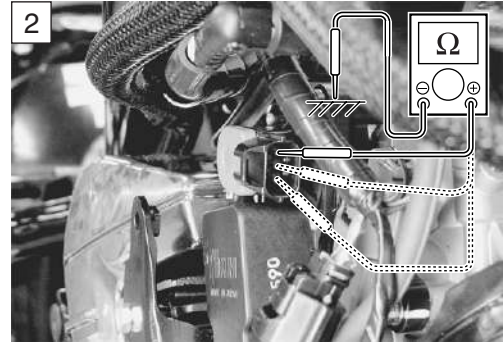

- 5) If OK, then measure the STP sensor resistance at the terminals (between Y/W wire (A) and B/Br wire (C)).
- 6) Close and open the secondary throttle valve by finger, and measure the valve closing and opening resistance.

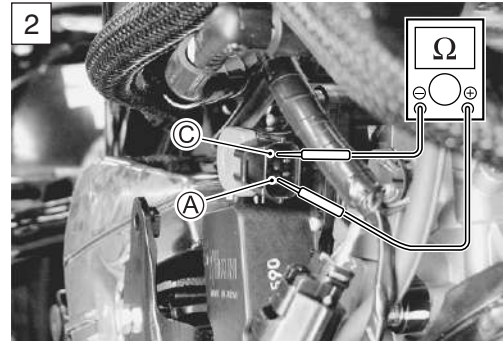

**DATA** STP sensor resistance  
Secondary throttle valve is closed: Approx. 0.6 k $\Omega$   
Secondary throttle valve is opened: Approx. 4.2 k $\Omega$   
(Y/W (A) – B/Br (C))

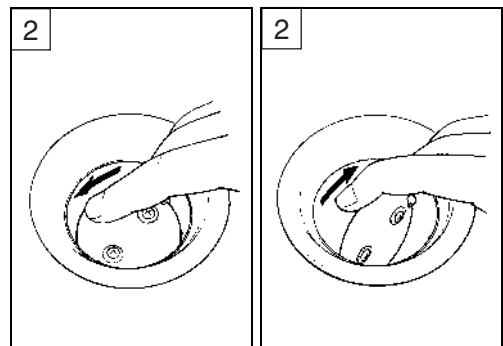

- 7) If OK, then measure the STP sensor resistance at the terminals (between Red wire (B) and B/Br wire (C)).

**DATA** STP sensor resistance: Approx. 5.0 k $\Omega$   
(Red (B) – B/Br (C))

**TOOL** 09900-25008: Multi-circuit tester set  
**Tester knob indication: Resistance ( $\Omega$ )**

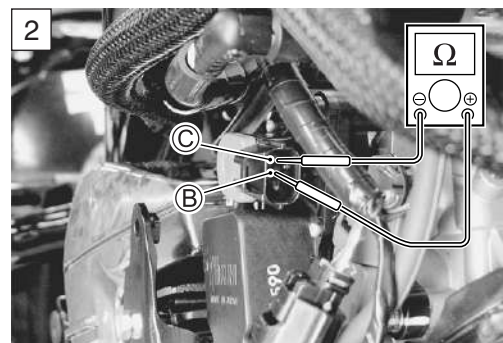

Are the continuity and resistance OK?

YES	Go to Step 3.
NO	<ul style="list-style-type: none"> <li>• Reset the STP sensor position correctly.</li> <li>• Replace the STP sensor with a new one.</li> </ul>

- 8) After repairing the trouble, clear the DTC using SDS tool. (☞ 5-26)

**Step 3**

- 1) Turn the ignition switch OFF.
- 2) Disconnect the STP sensor coupler and install the test harness.
- 3) Disconnect the STVA lead wire coupler.
- 4) Turn the ignition switch ON.
- 5) Measure the STP sensor output voltage at the terminals (between ⊕ terminal ① Y/W wire and ⊖ terminal ③ B/Br wire) by turning the secondary throttle valve (close and open) with a finger.

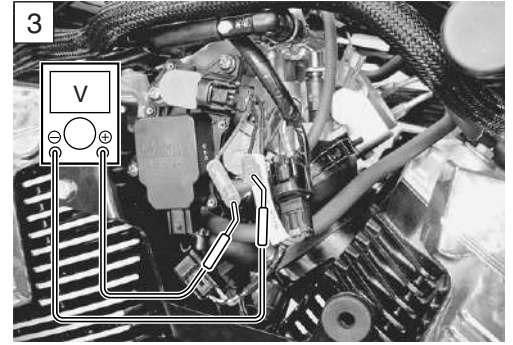

**DATA** STP sensor output voltage

Secondary throttle valve is closed: **Approx. 0.6 V**

Secondary throttle valve is opened: **Approx. 4.2 V**

**TOOL** 09900-25008: Multi-circuit tester set

09900-28630: TPS test wire harness

**V** Tester knob indication: Voltage (---)

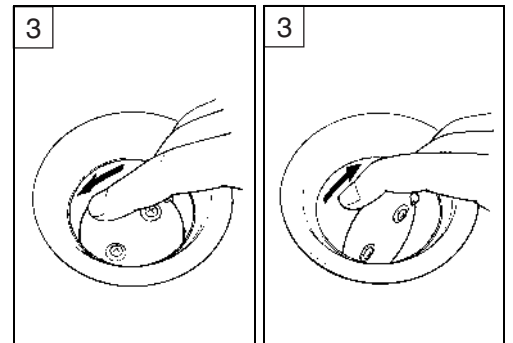

Is the voltage OK?

YES	<ul style="list-style-type: none"> <li>• Red, Y/W or B/Br wire open or shorted to ground, or poor ①, ②⑩ or ②⑨ connection</li> <li>• If wire and connection are OK, intermittent trouble or faulty ECM.</li> <li>• Recheck each terminal and wire harness for open circuit and poor connection.</li> <li>• Replace the ECM with a known good one, and inspect it again.</li> </ul>
NO	If check result is not satisfactory, replace STP sensor with a new one.

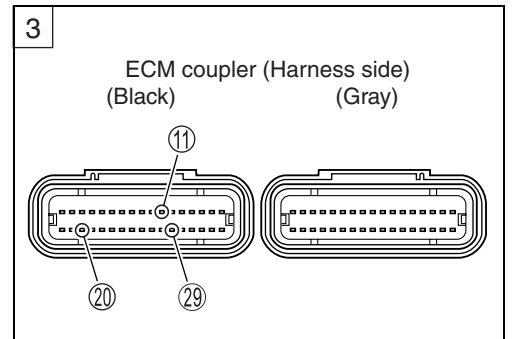

After repairing the trouble, clear the DTC using SDS tool.

(👉 5-26)



## “C31” (P0705) GP SWITCH CIRCUIT MALFUNCTION

DETECTED CONDITION	POSSIBLE CAUSE
No Gear Position switch voltage Switch voltage is not within the following range. Switch voltage > 0.6 V	<ul style="list-style-type: none"> <li>• Gear Position switch circuit open or short</li> <li>• Gear Position switch malfunction</li> <li>• ECM malfunction</li> </ul>

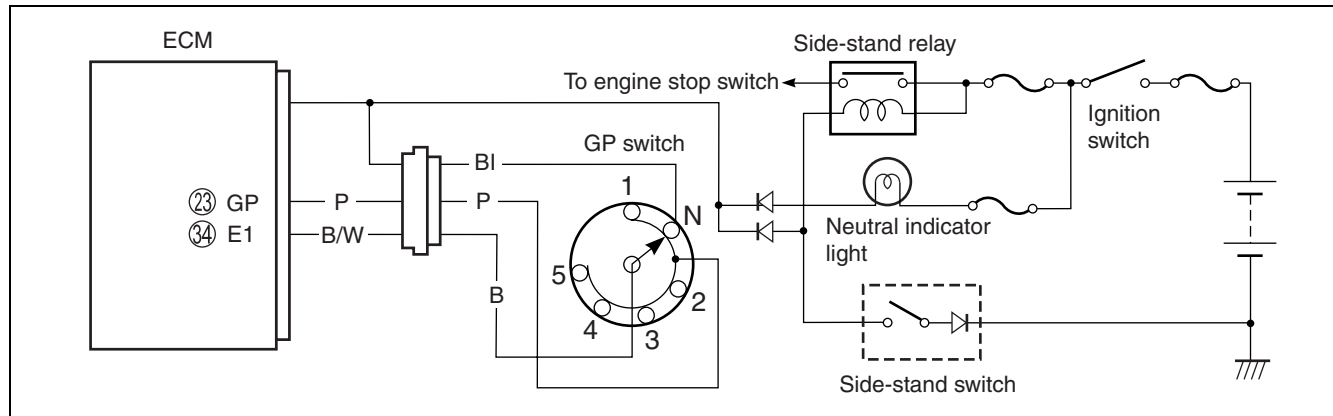

### INSPECTION

#### Step 1

- 1) Turn the ignition switch OFF.
- 2) Remove the right frame side cover. (➡ 9-5)
- 3) Check the GP switch coupler for loose or poor contacts.  
If OK, then measure the GP switch voltage.

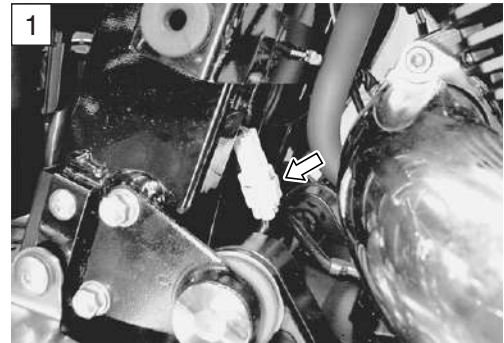

- 4) Support the motorcycle with a jack.
- 5) Fold the side-stand to up position.
- 6) Make sure the engine stop switch is in the “RUN” position.
- 7) Insert the needle pointed probe to the lead wire coupler.
- 8) Turn the ignition switch ON.
- 9) Measure the voltage at the wire side coupler between Pink wire and B/W wire, when shifting the gearshift lever from 1st to Top.

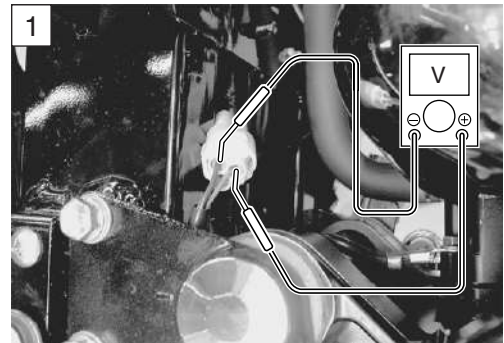

**DATA** GP switch voltage: 0.6 V and more  
(+ Pink – B/W)

**TOOL** 09900-25008: Multi-circuit tester set  
09900-25009: Needle pointed probe set

**TESTER** Tester knob indication: Voltage (V)



Is the voltage OK?

YES	<ul style="list-style-type: none"> <li>• Pink wire open or shorted to ground</li> <li>• If wire and connection are OK, intermittent trouble or faulty ECM.</li> <li>• Recheck each terminal and wire harness for open circuit and poor connection.</li> <li>• Replace the ECM with a known good one, and inspect it again.</li> </ul>
NO	<ul style="list-style-type: none"> <li>• Pink or B/W wire open, or Pink wire shorted to ground</li> <li>• Loose or poor contacts on the ECM coupler (terminal ②③ or ③④)</li> <li>• If wire and connection are OK, replace the GP switch with a new one.</li> </ul>

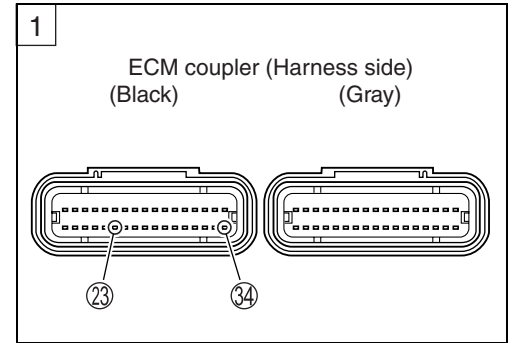

10) After repairing the trouble, clear the DTC using SDS tool.  
(☞ 5-26)

**“C32” (P0201) or “C33” (P0202) FUEL INJECTOR CIRCUIT MALFUNCTION**

DETECTED CONDITION	POSSIBLE CAUSE
CKP signals produced but fuel injector signal is interrupted continuous by 4 times or more.	<ul style="list-style-type: none"> <li>• Injector circuit open or short.</li> <li>• Injector malfunction.</li> <li>• ECM malfunction.</li> </ul>

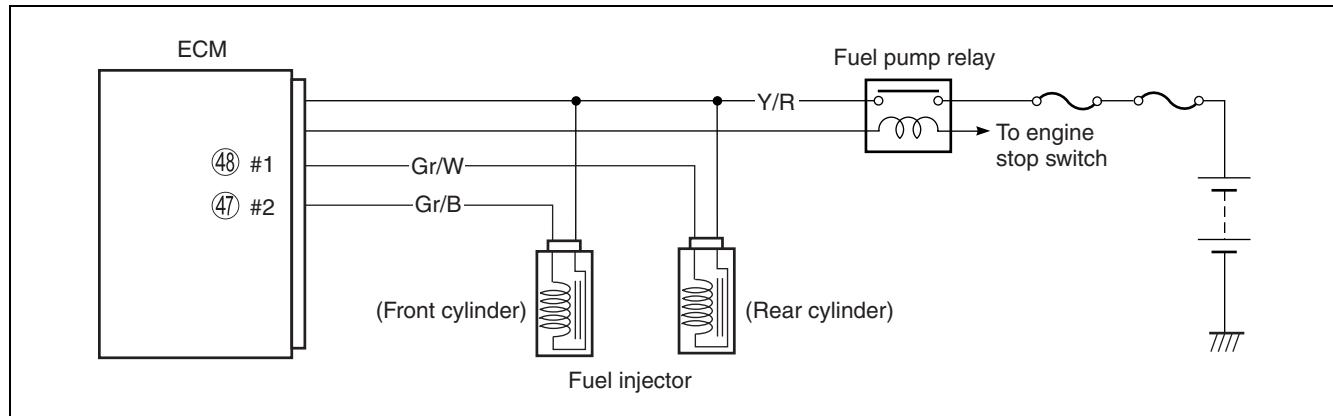
**INSPECTION**

(When indicating C32/P0201 for fuel injector #1)

(When indicating C33/P0202 for fuel injector #2)

**Step 1**

- 1) Remove the air cleaner chamber. (☞ 6-13)
- 2) Turn the ignition switch OFF.
- 3) Check the injector coupler (Front cylinder side ① or Rear cylinder side ②) for loose or poor contacts.  
If OK, then measure the injector resistance.
- 4) Disconnect the injector coupler and measure the resistance between terminals.

**DATA** Injector resistance: 11 – 13 Ω at 23 °C (73 °F)  
(Terminal – Terminal)

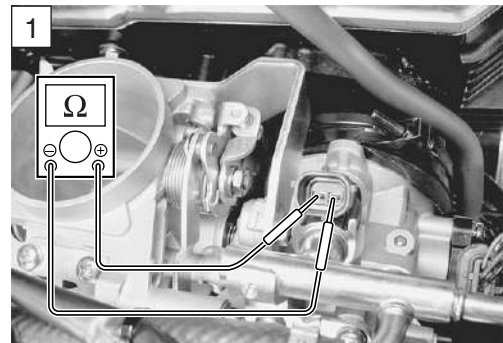
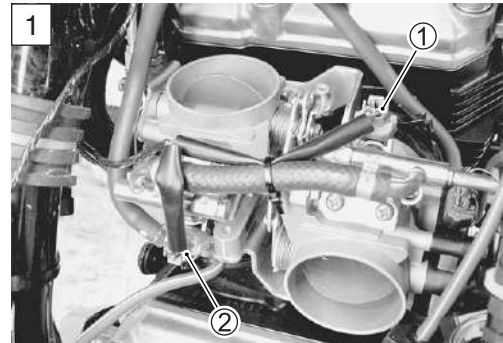

5) If OK, then check the continuity between each terminal and ground.

**DATA** STP sensor continuity:  $\infty \Omega$  (Infinity)

**TOOL** 09900-25008: Multi-circuit tester set

**Tester knob indication: Resistance ( $\Omega$ )**

Are the resistance and continuity OK?

YES	Go to Step 2.
NO	Replace the injector with a new one. (↗ 6-22)

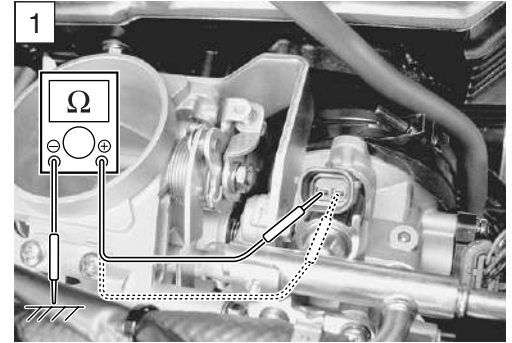

6) After repairing the trouble, clear the DTC using SDS tool. (↗ 5-26)

**Step 2**

- 1) Turn the ignition switch ON.
- 2) Measure the injector voltage between Y/R wire and ground.

**DATA** Injector voltage: Battery voltage  
(+ Y/R – - Ground)

**NOTE:**

Injector voltage can be detected only 3 for seconds after ignition switch is turned ON.

**TOOL** 09900-25008: Multi-circuit tester set

**Tester knob indication: Voltage (V)**

Is the voltage OK?

YES	<ul style="list-style-type: none"> <li>• Gr/B wire open or shorted to ground, or poor ④⑦ connection. (Front cylinder side)</li> <li>• Gr/W wire open or shorted to ground, or poor ④⑧ connection. (Rear cylinder side)</li> <li>• If wire and connection are OK, intermittent trouble or faulty ECM.</li> <li>• Recheck each terminal and wire harness for open circuit and poor connection.</li> <li>• Replace the ECM with a known good one, and inspect it again.</li> </ul>
NO	Open circuit in the Y/R wire

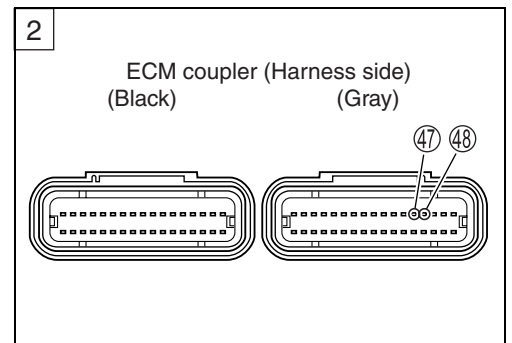
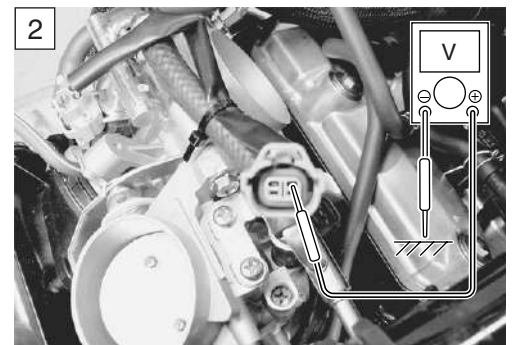

3) After repairing the trouble, clear the DTC using SDS tool. (↗ 5-26)

**“C40” (P0505-H/L or P0506 and P0507) ISC VALVE CIRCUIT MALFUNCTION**

DETECTED CONDITION		POSSIBLE CAUSE
C40 P0505	H	ISC valve motor current is higher than the specified value.
	L	ISC valve motor circuit is open.
P0506	Idle speed is lower than the desired idle speed.	<ul style="list-style-type: none"> <li>• ISC valve circuit shorted to BATT or ground circuit open</li> <li>• ISC valve circuit open or shorted to ground or BATT circuit open</li> <li>• W/Y or Lg wire open or short</li> <li>• ISC valve is fixed</li> <li>• Air circuit clogged</li> </ul>
P0507	Idle speed is higher than the desired idle speed.	<ul style="list-style-type: none"> <li>• W/Y or Dgr wire open or short</li> <li>• Disconnected ISC valve hose</li> </ul>

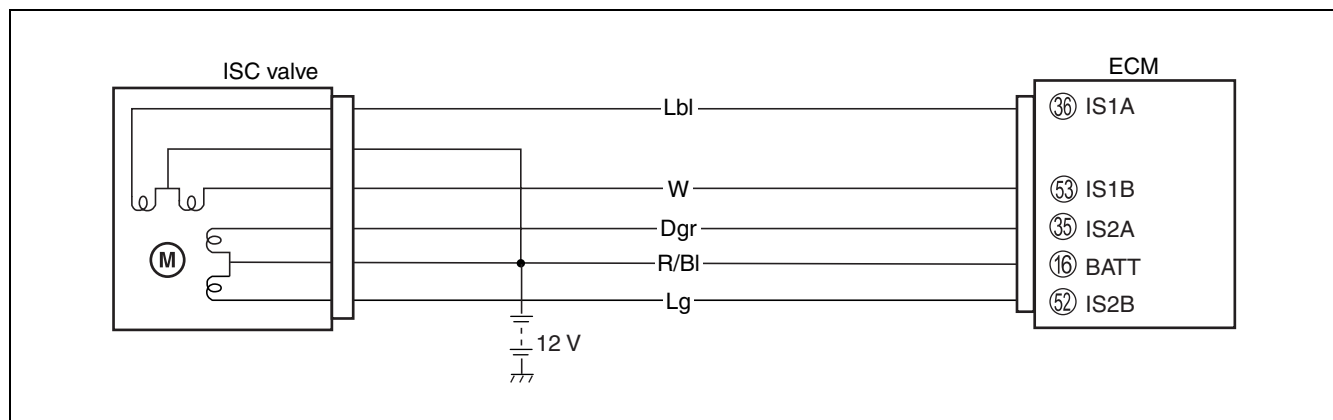
**CAUTION**

**Be careful not to disconnect at least 3 seconds after ignition switch is turned to OFF.**

**If the ECM coupler is disconnected within 3 seconds after ignition switch is turned to OFF, there is a possibility of an usual valve being written in ECM and causing an error of ISC valve operation.**

**INSPECTION**

**Step 1**

- 1) Remove the fuel tank. (☞ 6-3)
- 2) Turn the ignition switch OFF.
- 3) Check the ISC valve coupler for loose or poor contacts.
- 4) If OK, then check the ISC valve lead wire continuity.

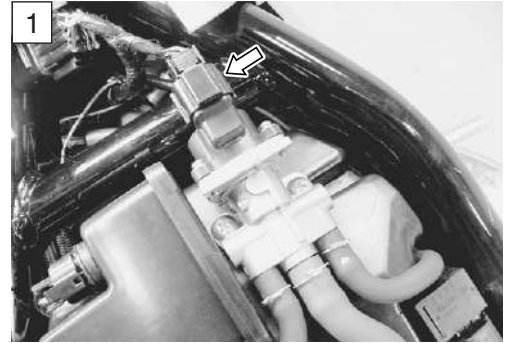

- 5) Disconnect the ISC valve coupler and ECM coupler. (☞ 5-37)
- 6) Check the continuity between terminals A and 33, terminals B and 16, terminals C and 36, terminals D and 52, terminals E and 16, and terminals F and 35.

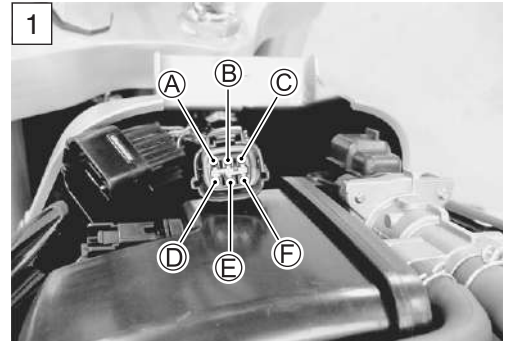

**CAUTION**

**When using the multi-circuit tester, do not strongly touch the terminal of the ECM coupler with a needle pointed tester probe to prevent the terminal damage or terminal bend.**

**DATA** ISC valve wire continuity: Continuity (•••)

**TOOL** 09900-25008: Multi-circuit tester set  
 09900-25009: Needle pointed probe set

**Tester knob indication: Continuity test (•••)**

Is the continuity OK?

YES	Go to Step 2.
NO	Lbl, W/Y, Dgr, R/Bl or Lg wire open.

- 7) After repairing the trouble, clear the DTC using SDS tool. (☞ 5-26)

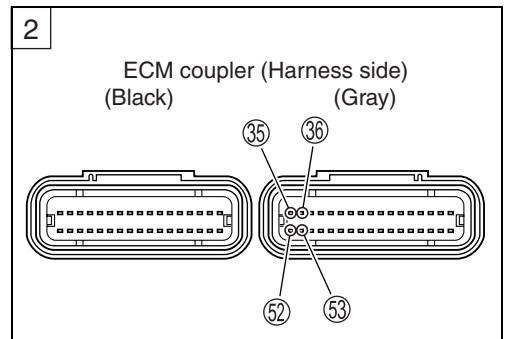

**Step 2**

- 1) Turn the ignition switch OFF.
- 2) Disconnect the ISC valve coupler.
- 3) Check the continuity between terminals ① and ③, terminals ② and ④.

**DATA** ISC valve continuity: Approx.  $\infty \Omega$  (Infinity)

(Terminal ① – Terminal ③)

(Terminal ② – Terminal ④)

- 4) If OK, then measure the resistance between terminals ① and ②, terminals ③ and ④.

**DATA** ISC valve resistance: Approx.  $30 \pm 1.2 \Omega$  at 20 °C (68 °F)

(Terminal ① – Terminal ②)

(Terminal ③ – Terminal ④)

Is the resistance OK?

YES	If wire is OK, intermittent trouble or faulty ECM.
NO	Replace the ISC valve with a new one.

- 5) After repairing the trouble, clear the DTC using SDS tool.  
( 5-26)

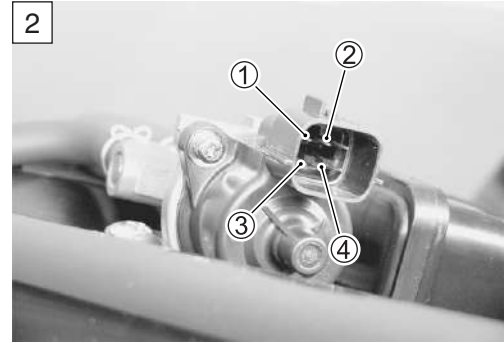



**ACTIVE CONTROL INSPECTION (ISC RPM CONTROL)**

**Check 1**

- 1) Set up the SDS tool. (Refer to the SDS operation manual for further details.)
- 2) Check that the engine is running.
- 3) Click the “Active control”.
- 4) Click the “ISC rpm control” ①.

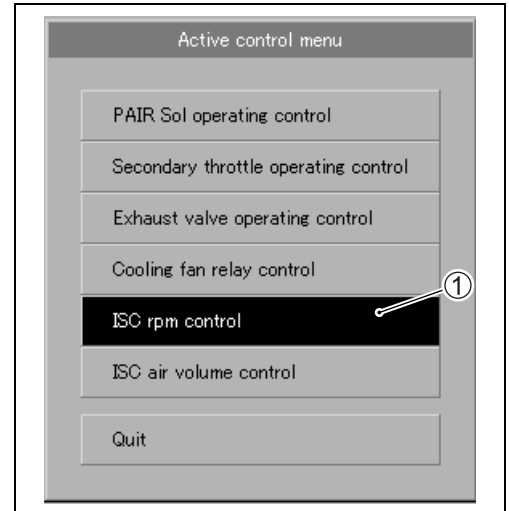

- 5) Check that the “Spec” ② is 900 rpm.
- 6) Check that the “Desired idle speed” ③ is 900 rpm.

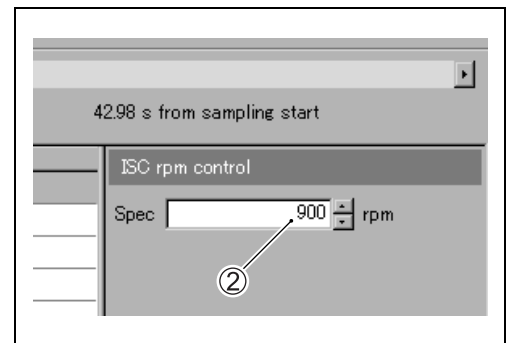

<input type="checkbox"/> Engine speed	869	rpm
<input type="checkbox"/> Engine coolant / oil temperature	88.6	°C
<input type="checkbox"/> Intake air temperature	50.9	°C
<input type="checkbox"/> Throttle position	28.4	°
<input type="checkbox"/> Desired idle speed	③ → 904	rpm
<input type="checkbox"/> ISC valve position	68	step

**Check 2**

- 1) Click the button ① and decrease the “Spec” ② to 800 rpm slowly.
- 2) Check that the “Desired idle speed” ③ is nearly equal to the “Spec” ②. At the same time, check that the number of steps in the ISC valve position decreases.
- 3) Click the button ④ and increase the “Spec” ② slowly.
- 4) Check that the “Desired idle speed” ③ is nearly equal to the “Spec” ②. Also, check that the number of steps ⑤ in the ISC valve position increases.

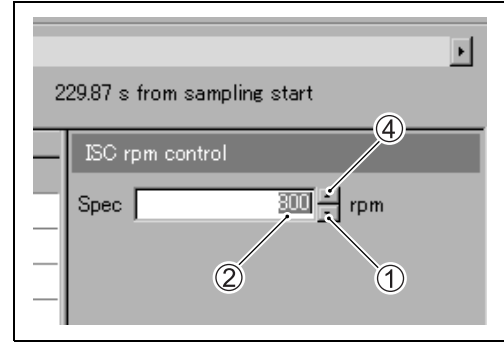

<input type="checkbox"/> Engine speed	707	rpm
<input type="checkbox"/> Engine coolant / oil temperature	100.5	°C
<input type="checkbox"/> Intake air temperature	50.9	°C
<input type="checkbox"/> Throttle position	28.4	°
<input type="checkbox"/> Desired idle speed	③ → 803	rpm
<input type="checkbox"/> ISC valve position	⑤ → 58	step

**Check 3**

- 1) Click the button ① and increase the “Spec” ② to 1 200 rpm slowly.
- 2) Check that the “Desired idle speed” ③ is nearly equal to the “Spec” ②. Also, check that the number of steps ④ in the ISC valve position increases.

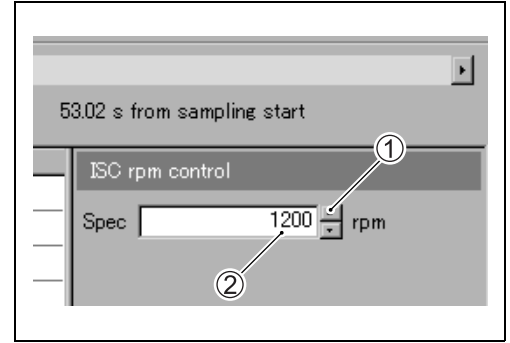

**CAUTION**

**Be careful not to increase the “Spec” to 1 500 rpm, or the “Engine speed” may reach the upper limit.**

<input type="checkbox"/> Engine speed	1176	rpm
<input type="checkbox"/> ISC valve position	④ → 87	step
<input type="checkbox"/> Desired idle speed	③ → 1205	rpm
<input type="checkbox"/> Engine coolant / oil temperature	96.1	°C
<input type="checkbox"/> Intake air temperature	61.6	°C
<input type="checkbox"/> Throttle position	28.4	°

**Check 4**

- 1) Increase the “Spec” ① to 1 400 rpm.
- 2) Check that the “Desired idle speed” ② is approx. 1 400 rpm.
- 3) Check that the “Engine speed” ③ is close to 1 400 rpm.

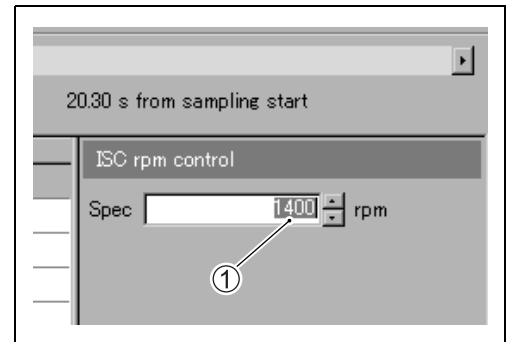

**CAUTION**

**Be careful not to increase the “Spec” to 1 500 rpm, or the “Engine speed” may reach the upper limit.**

<input type="checkbox"/> Engine speed	③ → 1411	rpm
<input type="checkbox"/> ISC valve position	93	step
<input type="checkbox"/> Desired idle speed	② → 1405	rpm
<input type="checkbox"/> Engine coolant / oil temperature	101.8	°C
<input type="checkbox"/> Intake air temperature	61.6	°C
<input type="checkbox"/> Throttle position	28.4	°

If the ISC valve does not function properly, inspect the ISC valve for details. (↪ 6-18)

### “C41” (P0230-H/L) FP RELAY CIRCUIT MALFUNCTION

DETECTED CONDITION		POSSIBLE CAUSE
C41	No voltage is applied to fuel pump although fuel pump relay is turned ON, or voltage is applied to fuel pump, although fuel pump relay is turned OFF.	<ul style="list-style-type: none"> <li>Fuel pump relay circuit open or short</li> <li>Fuel pump relay malfunction</li> <li>ECM malfunction</li> </ul>
P0230		
P0230	H	<ul style="list-style-type: none"> <li>Fuel pump relay switch circuit shorted to power source</li> <li>Faulty fuel pump relay (switch side)</li> <li>Fuel pump relay coil circuit open or short</li> <li>Faulty fuel pump relay (coil side)</li> </ul>
	L	

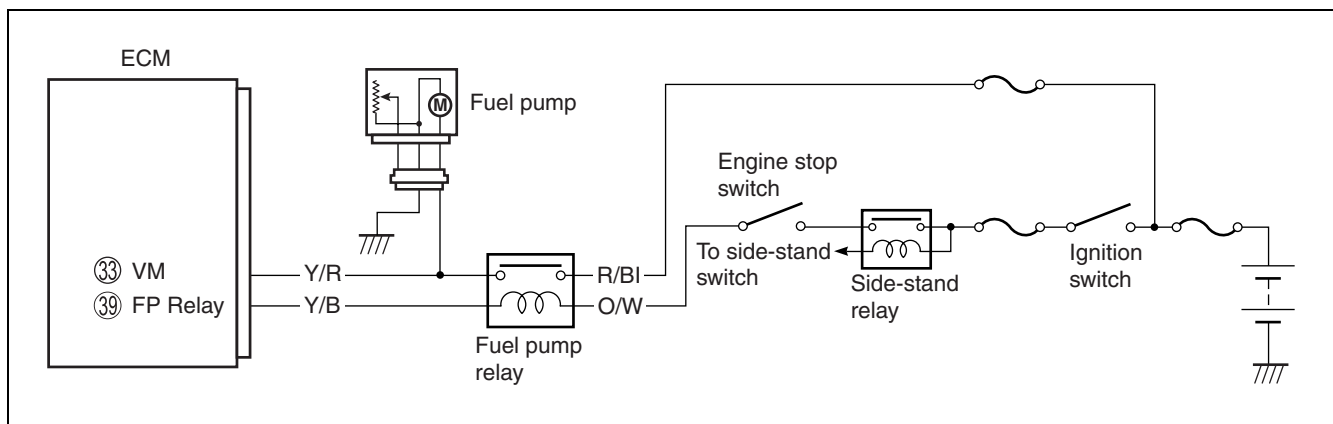

#### INSPECTION

##### Step 1 (When indicating C41:)

- Turn the ignition switch OFF.
- Remove the right frame side cover. (↗ 9-5)
- Check the FP relay coupler for loose or poor contacts.  
If OK, then check the FP relay. (↗ 6-6)

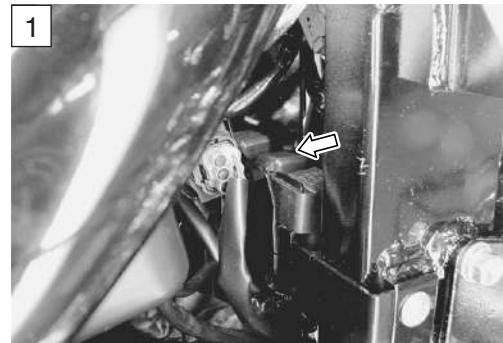

Is the FP relay OK?

YES	<ul style="list-style-type: none"> <li>Y/B or O/W wire open or short or poor 39 connection</li> <li>Y/R or R/BI wire open, shorted or poor 33 connection</li> <li>If wire and connection are OK, intermittent trouble or faulty ECM.</li> <li>Recheck each terminal and wire harness for open circuit and poor connection.</li> <li>Replace the ECM with a known good one, and inspect it again.</li> </ul>
NO	Replace the FP relay with a new one.

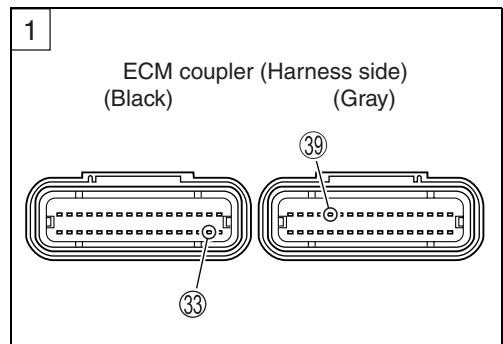

**Step 1 (When indicating P0230-H:)**

- 1) Turn the ignition switch OFF.
- 2) Remove the right frame side cover. (☞ 9-5)
- 3) Check the FP relay coupler for loose or poor contacts.  
If OK, then check the FP relay. (☞ 6-6)

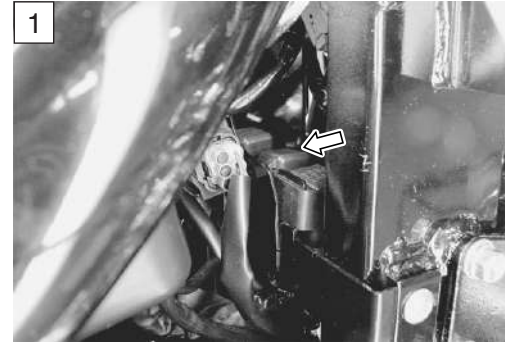

Is the FP relay OK?

YES	<ul style="list-style-type: none"> <li>• Y/R wire shorted to power source</li> <li>• Y/B wire shorted to ground</li> <li>• If wire and connection are OK, intermittent trouble or faulty ECM.</li> <li>• Recheck each terminal and wire harness for open circuit and poor connection.</li> <li>• Replace the ECM with a known good one, and inspect it again.</li> </ul>
NO	Replace the FP relay with a new one.

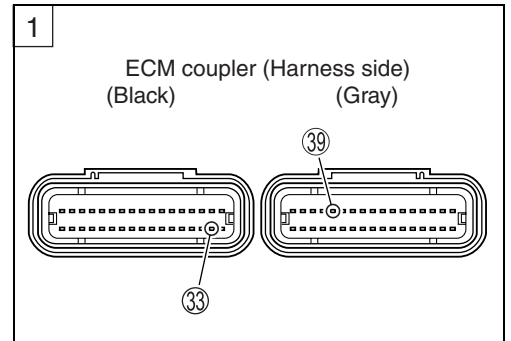

- 4) After repairing the trouble, clear the DTC using SDS tool. (☞ 5-26)

**Step 1 (When indicating P0230-L:)**

- 1) Turn the ignition switch OFF.
- 2) Remove the right frame side cover. (☞ 9-5)
- 3) Check the FP relay coupler for loose or poor contacts.  
If OK, then check the FP relay. (☞ 6-6)

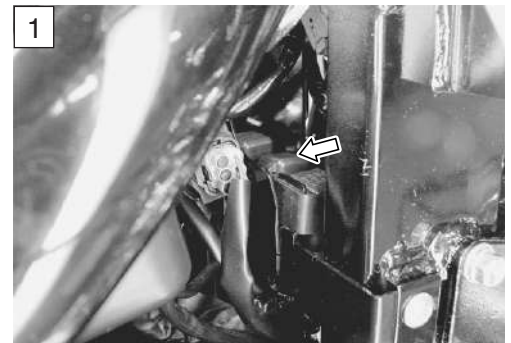

Is the FP relay OK?

YES	<ul style="list-style-type: none"> <li>• Y/B wire open or poor ③⑨ connection</li> <li>• O/W wire open or shorted to ground</li> <li>• R/BI or Y/R wire open or shorted to ground or poor ③③ connection</li> <li>• If wire and connection are OK, intermittent trouble or faulty ECM.</li> <li>• Recheck each terminal and wire harness for open circuit and poor connection.</li> <li>• Replace the ECM with a known good one, and inspect it again.</li> </ul>
NO	Replace the FP relay with a new one.

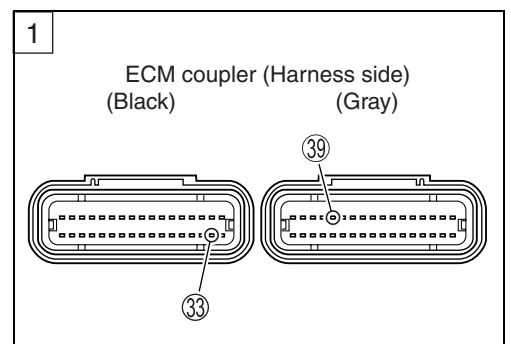

- 4) After repairing the trouble, clear the DTC using SDS tool. (☞ 5-26)

**“C42” (P01650) IG SWITCH CIRCUIT MALFUNCTION**

DETECTED CONDITION	POSSIBLE CAUSE
Ignition switch signal is not input to the ECM.	<ul style="list-style-type: none"><li>• Ignition system circuit open or short</li><li>• ECM malfunction</li></ul>

**INSPECTION**

\* Refer to the **IGNITION SWITCH INSPECTION** for details. (☞ 10-42)



## “C44” (P0156/P0161) or “C64” (P0130/P0135) HO2 SENSOR (HO2S) CIRCUIT MALFUNCTION (FOR E-02, 19, 24)

DETECTED CONDITION		POSSIBLE CAUSE
C44/C64 (P0156/P0130)	HO2 sensor output voltage is not input to ECM during engine operation and running condition. (Sensor voltage < 0.45 V)	<ul style="list-style-type: none"> <li>HO2 sensor circuit open or shorted to ground.</li> <li>Fuel system malfunction.</li> <li>ECM malfunction.</li> </ul>
C44/C64 (P0161/P0135)	The heater can not operate so that heater operation voltage is not supply to the oxygen heater circuit.	<ul style="list-style-type: none"> <li>Battery voltage supply to the HO2 sensor.</li> </ul>

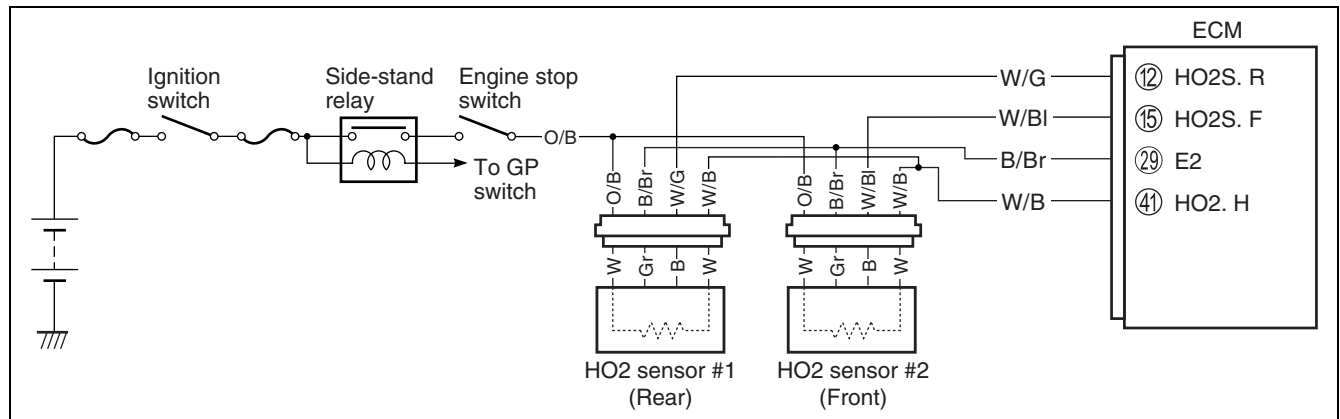

### INSPECTION

#### Step 1

(When indicating C44/P0156 for HO2 sensor #2)

(When indicating C64/P0130 for HO2 sensor #1)

- 1) Turn the ignition switch OFF.
- 2) Check the HO2 sensor for loose or poor contacts.  
If OK, then check the HO2 sensor lead wire continuity.

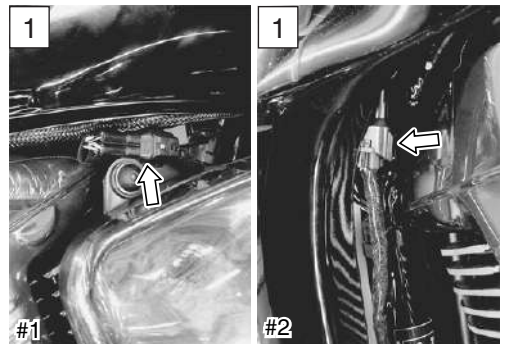

- 3) Disconnect the HO2 sensor coupler.
- 4) Check the continuity between W/G (#1) or W/BI (#2) wire (A) and ground.
- 5) Also, check the continuity between W/G (#1) or W/BI (#2) wire (A) and B/Br wire (B). If the sound is not heard from the tester, the circuit condition is OK.

**TOOL** 09900-25008: Multi-circuit tester set

**Tester knob indication: Continuity test (•••)**

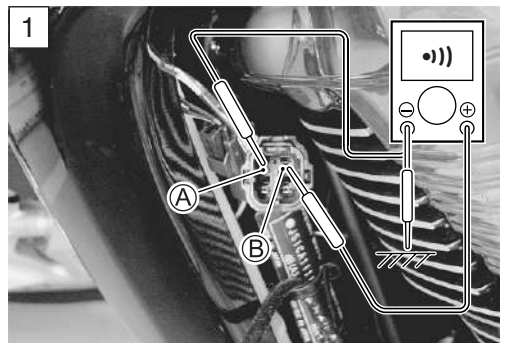

- 6) Disconnect the ECM coupler. (☞ 5-37)
- 7) Check the continuity between W/G or W/BI wire (A) and terminal 12, 15.
- 8) Also, check the continuity between B/Br wire (B) and terminal 29.

**CAUTION**

When using the multi-circuit tester, do not strongly touch the terminal of the ECM coupler with a needle pointed tester probe to prevent the terminal damage or terminal bend.

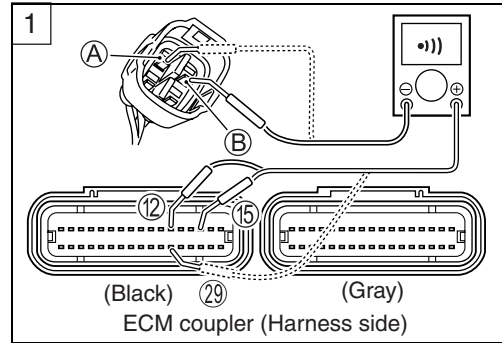

**DATA** HO2S lead wire continuity: Continuity (•••)

- TOOL** 09900-25008: Multi-circuit tester set
- 09900-25009: Needle pointed probe set

**Tester knob indication: Continuity test (•••)**

Is the continuity OK?

YES	Go to Step 2. (When indicating C44/P0130:)
NO	W/G or W/BI wire shorted to ground, or W/G and W/BI or B/Br wire open.

- 9) After repairing the trouble, clear the DTC using SDS tool. (☞ 5-26)

**Step 2**

- 1) Connect the ECM coupler and HO2 sensor coupler.
- 2) Warm up the engine enough.
- 3) Measure the HO2 sensor output voltage between W/G or W/BI wire and B/Br wire, when idling condition.

**DATA** HO2 sensor output voltage at idle speed:  
0.4 V and less (+ W/G or W/BI – – B/Br)

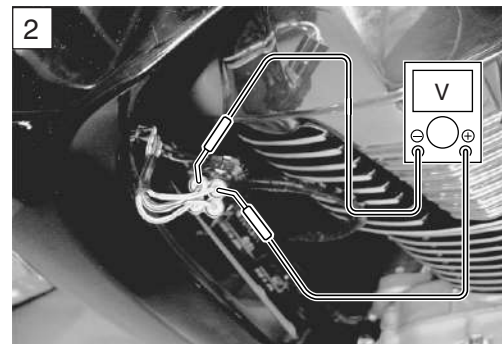

- 4) If OK, then pinch the PAIR hose ① with a proper hose clamp.
- 5) Remove the fuel tank (☞ 6-3) and frame head covers (☞ 9-6).
- 6) Measure the HO2 sensor output voltage while holding the engine speed at 3 000 r/min.

**DATA** HO2 sensor output voltage at 3 000 r/min:  
0.6 V and more (+ W/G or W/BI – – B/Br)

- TOOL** 09900-25008: Multi-circuit tester set
- 09900-25009: Needle pointed probe set

**Tester knob indication: Voltage (---)**

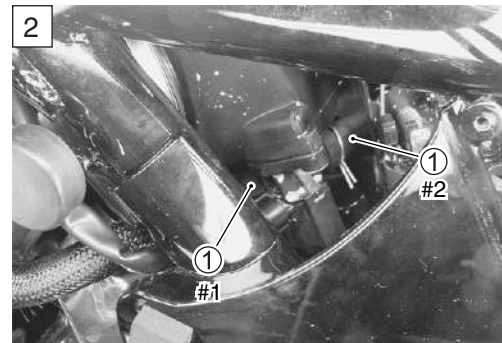

Is the voltage OK?

YES	<ul style="list-style-type: none"> <li>• W/G wire or B/Br wire open or shorted to ground, or poor ⑫, ⑮ or ⑲ connection.</li> <li>• If wire and connection are OK, intermittent trouble or faulty ECM.</li> <li>• Recheck each terminal and wire harness for open circuit and poor connection.</li> <li>• Replace the ECM with a known good one, and inspect it again.</li> </ul>
NO	Replace the HO2 sensor with a new one.

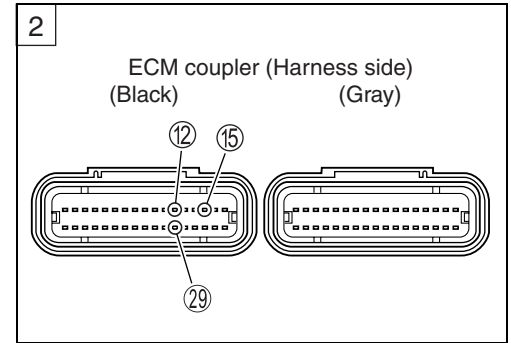

7) After repairing the trouble, clear the DTC using SDS tool.  
(☞ 5-26)

**Step 1**  
**(When indicating C44/P0161 for HO2 sensor #2)**

**(When indicating C64/P0135 for HO2 sensor #1)**

- 1) Turn the ignition switch OFF.
- 2) Check the HO2 sensor for loose or poor contacts.  
If OK, then check the HO2 sensor resistance.

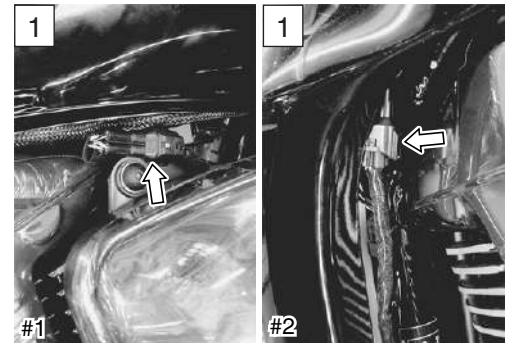

- 3) Disconnect the HO2 sensor coupler and measure the resistance between terminals.

**DATA** HO2 heater resistance: 4.0 – 5.5 Ω at 23 °C (73.4 °F)  
(White – White)

**NOTE:**

- \* Temperature of the sensor affects resistance value largely.
- \* Make sure that the sensor heater is at correct temperature.

**TOOL** 09900-25008: Multi-circuit tester set

**Tester knob indication: Resistance (Ω)**

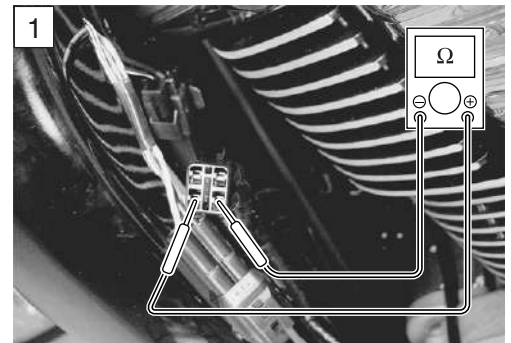

Is the voltage OK?

YES	Go to Step 2.
NO	Replace the HO2 sensor with a new one.

4) After repairing the trouble, clear the DTC using SDS tool.  
(☞ 5-26)

**Step 2**

- 1) Connect the HO2 sensor coupler.
- 2) Insert the needle pointed probes to the HO2 sensor coupler.
- 3) Turn the ignition switch ON and measure the heater voltage between W/B wire and ground.
- 4) If the tester voltage indicates the battery voltage, it is good condition.

**DATA** Heater voltage: **Battery voltage**  
 (+ W/B - (-) Ground)

**NOTE:**

Battery voltage can be detected only before starting the engine.

**TOOL** 09900-25008: Multi-circuit tester set  
 09900-25009: Needle pointed probe set

**Tester knob indication: Voltage (V)**

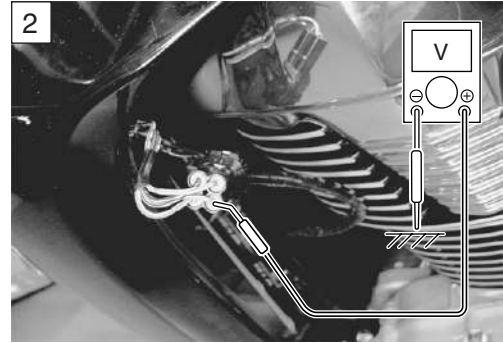

Is the voltage OK?

YES	<ul style="list-style-type: none"> <li>• W/B wire open or shorted to ground, or poor (41) connection.</li> <li>• Recheck each terminal and wire harness for open circuit and poor connection.</li> <li>• If wire and connection are OK, intermittent trouble or faulty ECM.</li> <li>• Replace the ECM with a known good one, and inspect it again.</li> </ul>
NO	Open or short circuit in the W/B wire. Loose or poor contacts on the ECM coupler (terminal (41)) or HO2 sensor coupler.

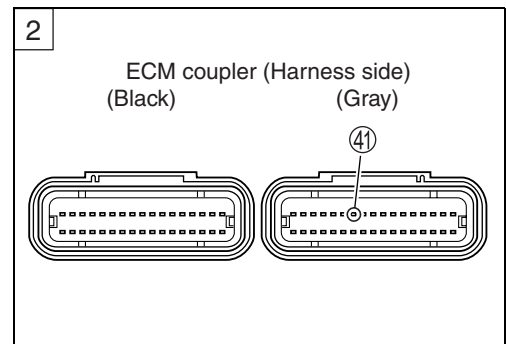

- 5) After repairing the trouble, clear the DTC using SDS tool. (5-26)

## “C46” (P1657-H/L or P1658) EXCVA ACTUATOR CIRCUIT MALFUNCTION

DETECTED CONDITION		POSSIBLE CAUSE
C46	The operation signal does not reach the EXCVA actuator. EXCVA position sensor voltage low or high $0.1\text{ V} \leq \text{Sensor voltage} < 4.9\text{ V}$ (without the above range)	<ul style="list-style-type: none"> <li>• EXCVA maladjusted</li> <li>• EXCVA circuit open or short</li> <li>• EXCVA motor malfunction</li> <li>• EXCVA position sensor malfunction</li> </ul>
P1657	H Sensor voltage is higher than specified value.	<ul style="list-style-type: none"> <li>• EXCVA position sensor circuit shorted to VCC or ground circuit open</li> <li>• EXCVA position sensor circuit open or shorted to ground or VCC circuit open</li> </ul>
	L Sensor voltage is lower than specified value.	
P1658	The operation signal does not reach the EXCVA motor. ECM does not receive communication signal from the STVA motor.	<ul style="list-style-type: none"> <li>• EXCVA motor circuit open or short</li> <li>• EXCVA motor malfunction</li> </ul>

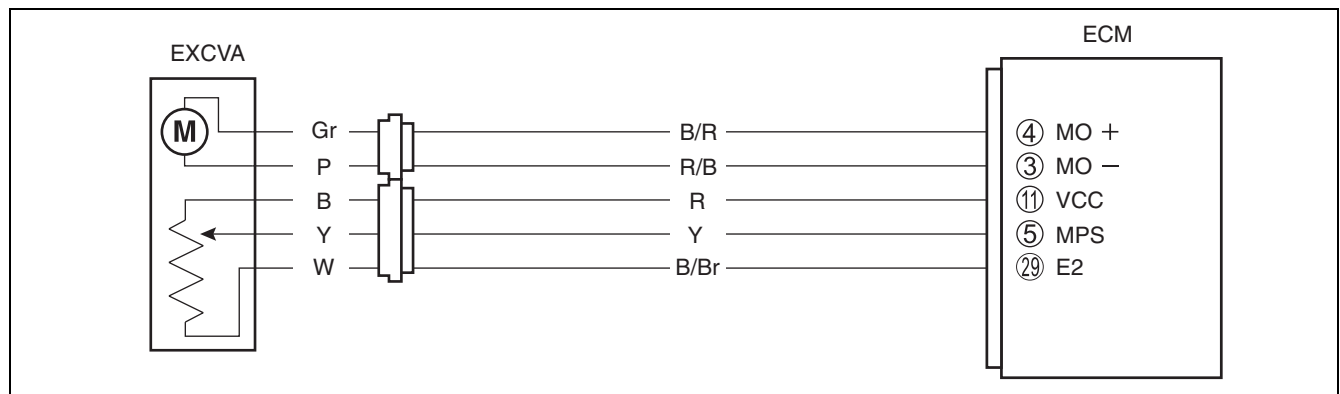

### INSPECTION

#### Step 1 (When indicating C46:)

- 1) Turn the ignition switch OFF.
- 2) Remove the lower frame cover. (→ 7-8)
- 3) Check the EXCVA lead wire coupler for loose or poor contacts.

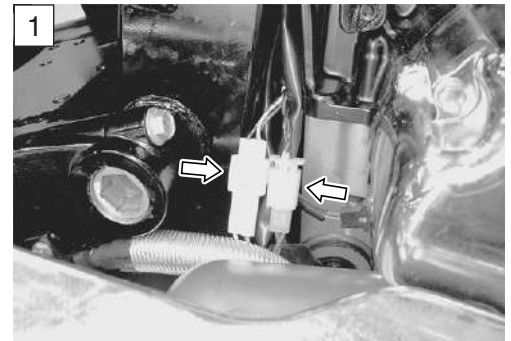

- 4) Turn the ignition switch ON.
- 5) Check the operation of the EXCVA.  
(EXCVA operating order: Full close → Full open → 30% open)

#### NOTE:

Install the EXCVA rubber cover correctly after checking the EXCVA.



Is the operation OK?

YES	Go to Step 2.
NO	Go to Step 6.

**Step 1 (When indicating P1657-H:)**

- 1) Turn the ignition switch OFF.
- 2) Remove the lower frame cover. (☞ 7-8)
- 3) Check the EXCVA position sensor coupler for loose or poor contacts.  
If OK, then check the EXCVA position sensor lead wire continuity.

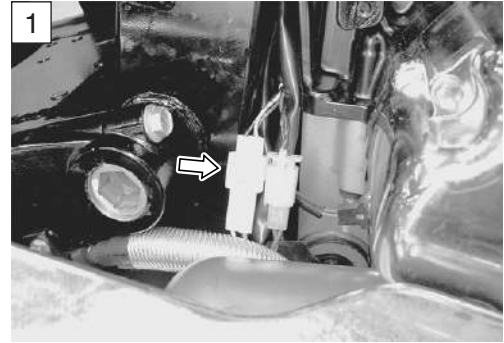

- 4) Disconnect the EXCVA position sensor coupler.
- 5) Check the continuity between Red wire (C) and Yellow wire (A).  
If the sound is not heard from the tester, the circuit condition is OK.

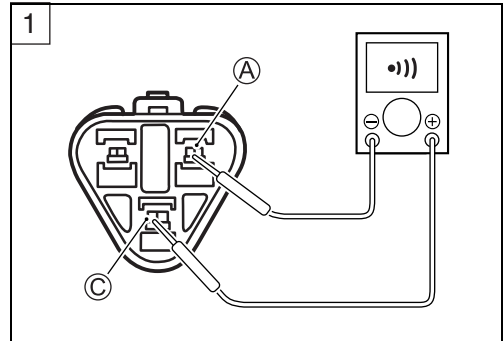

- 6) Disconnect the ECM coupler. (☞ 5-37)
- 7) Check the continuity between Yellow wire (A) and terminal (5).
- 8) Also, check the continuity between B/Br wire (B) and terminal (29).

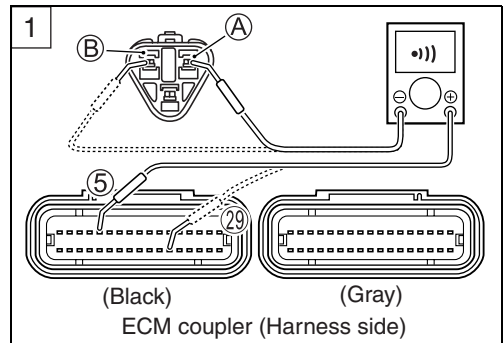

**CAUTION**

When using the multi-circuit tester, do not strongly touch the terminal of the ECM coupler with a needle pointed tester probe to prevent the terminal damage or terminal bend.

**DATA** EXCVA lead wire continuity: Continuity (•))

**TOOL** 09900-25008: Multi-circuit tester set  
09900-25009: Needle probe set

**Tester knob indication: Continuity test (•))**

Is the continuity OK?

YES	Go to Step 4.
NO	Yellow wire shorted to VCC, or B/Br wire open

- 9) After repairing the trouble, clear the DTC using SDS tool. (☞ 5-26)



**Step 1 (When indicating P1657-L:)**

- 1) Turn the ignition switch OFF.
- 2) Remove the lower frame cover. (➡ 7-8)
- 3) Check the EXCVA position sensor coupler for loose or poor contacts.  
If OK, then check the EXCVA position sensor lead wire continuity.

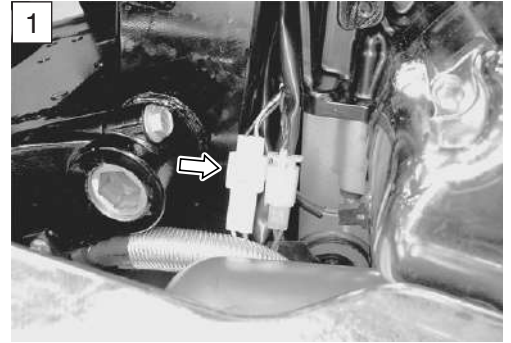

- 4) Disconnect the EXCVA position sensor coupler.
- 5) Check the continuity between Yellow wire (A) and ground.
- 6) Also, check the continuity between Yellow wire (A) and B/Br wire (B). If the sound is not heard from the tester, the circuit condition is OK.

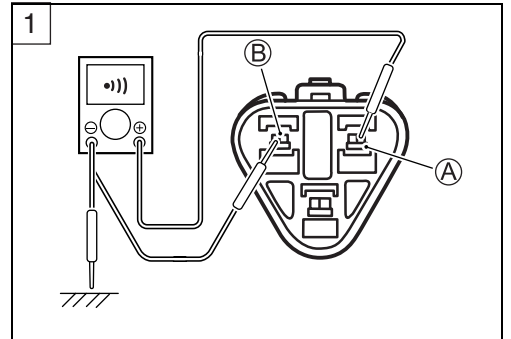

- 7) Disconnect the ECM coupler. (➡ 5-37)
- 8) Check the continuity between Yellow wire (A) and terminal (5).
- 9) Also, check the continuity between Red wire (C) and terminal (11).

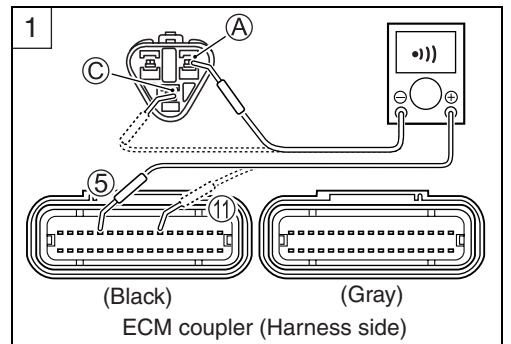

**CAUTION**

**When using the multi-circuit tester, do not strongly touch the terminal of the ECM coupler with a needle pointed tester probe to prevent the terminal damage or terminal bend.**

**DATA** EXCVA lead wire continuity: Continuity (•••)

**TOOL** 09900-25008: Multi-circuit tester set  
09900-25009: Needle pointed probe set

**Tester knob indication: Continuity test (•••)**

Is the continuity OK?

YES	Go to Step 2 and Go to Step 4.
NO	Red or Yellow wire open, or Yellow wire shorted to ground

- 10) After repairing the trouble, clear the DTC using SDS tool. (➡ 5-26)

**Step 1 (When indicating P1658:)**

- 1) Turn the ignition switch OFF.
- 2) Remove the lower frame cover. (↗ 7-8)
- 3) Check the EXCVA motor coupler for loose or poor contacts.

Is the contacting OK?

YES	Go to Step 6.
NO	Loose or poor contacts on the EXCV motor coupler

- 4) After repairing the trouble, clear the DTC using SDS tool. (↗ 5-26)



**Step 2**

- 1) Turn the ignition switch OFF.
- 2) Check the installation of EXCV cables. (↗ 7-12)  
If it is necessary, adjust the EXCV cables. (↗ 7-4)



- 3) Disconnect the EXCVA position sensor lead wire coupler.
- 4) Turn the ignition switch ON.
- 5) Measure the voltage between the Red wire terminal ① and ground.
- 6) If OK, then measure the voltage between the Red wire terminal ① and B/Br wire terminal ②.

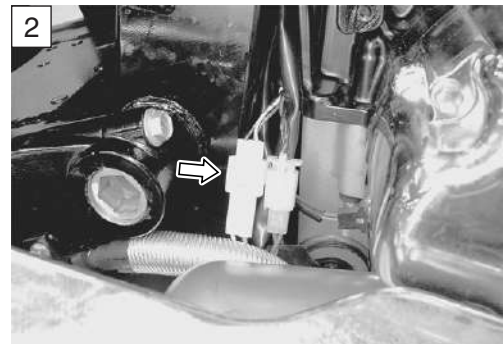

**DATA** Position sensor input voltage: 4.5 – 5.5 V  
 (+ Red – ⊖ Ground)  
 (+ Red – ⊖ B/Br)

**TOOL** 09900-25008: Multi circuit tester set

**Tester knob indication: Voltage (V)**

Is the voltage OK?

YES	Go to Step 3.
NO	<ul style="list-style-type: none"> <li>• Loose or poor contacts on the ECM coupler (terminal ①① or ②⑨)</li> <li>• Open or short circuit in the Red wire or B/Br wire</li> </ul>

- 7) After repairing the trouble, clear the DTC using SDS tool. (↗ 5-26)

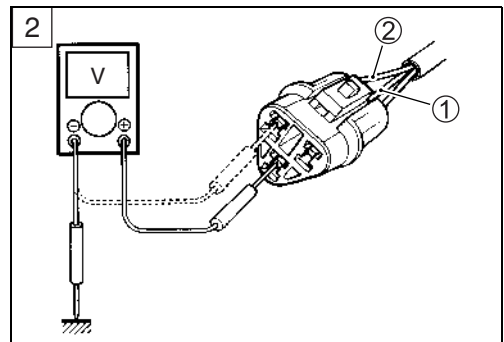

**Step 3**

- 1) Turn the ignition switch OFF.
- 2) Check the continuity between Yellow wire and ground.

**DATA** Position sensor continuity:  $\infty \Omega$  (Infinity)

- 3) If OK, then measure the position sensor resistance.

- 4) Connect the position sensor coupler.
- 5) Set the EXCVA to adjustment position. (↔ 7-2)

- 6) Disconnect the position sensor coupler and measure the resistance. (between Yellow and White wires)

**DATA** Position sensor resistance at adjustment position:  
Approx. 3.1 k $\Omega$  (+ Yellow – - White)

**TOOL** 09900-25008: Multi circuit tester set

**Tester knob indication: Resistance ( $\Omega$ )**

Is the resistance OK?

YES	Go to Step 4.
NO	Replace the EXCVA with a new one.

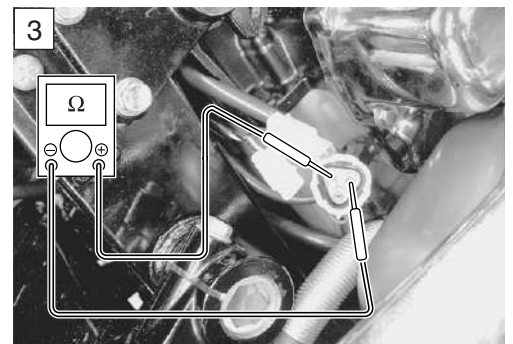
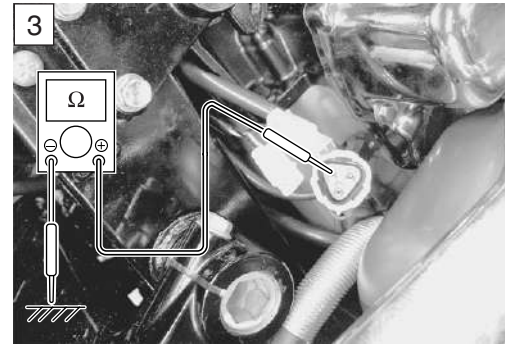

**Step 4**

- 1) Turn the ignition switch OFF.
- 2) Connect the position sensor coupler.
- 3) Measure the position sensor output voltage at fully close position and fully open position.
- 4) Insert the needle pointed probes to the back side of the position sensor lead wire coupler. (+ Yellow – B/Br)
- 5) Disconnect the EXCVA motor lead wire coupler.
- 6) To set the EXCV to fully close position, apply 12 volts to (A) and (B) terminals.  
 Positive wire – (A) (Pink wire) terminal  
 Negative wire – (B) (Gray wire) terminal
- 7) Turn the ignition switch ON.
- 8) Measure the position sensor output voltage at fully close position.
- 9) Then, to set the EXCV to fully open position, apply 12 volts to (B) and (A) terminals.  
 Positive wire – (B) (Gray wire) terminal  
 Negative wire – (A) (Pink wire) terminal
- 10) Measure the position sensor output voltage at fully open position.

**DATA** Position sensor output voltage  
 EXCV is fully close: 0.5 – 1.5 V  
 EXCV is fully open: 3.5 – 4.5 V  
 (+ Yellow – B/Br)

**TOOL** 09900-25008: Multi circuit tester set  
 09900-25009: Needle pointed probe set

**Tester knob indication: Voltage (V)**

Is the voltage OK?

YES	Replace the ECM with a known good one, and inspect it again.
NO	Go to Step 5.

- 11) After repairing the trouble, clear the DTC using SDS tool. (5-26)

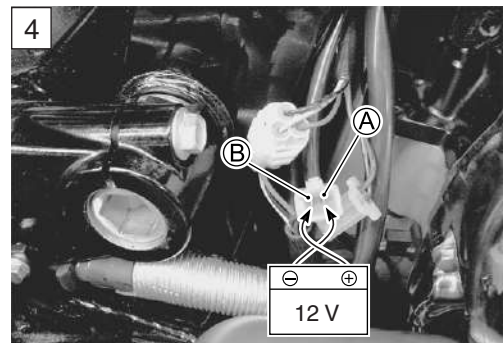
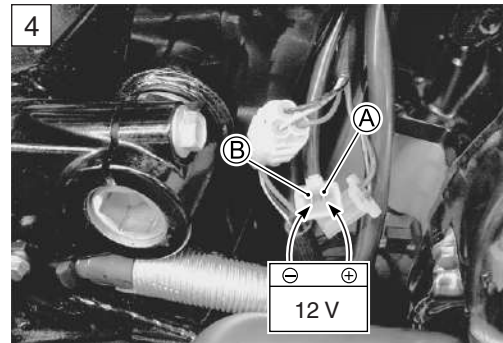
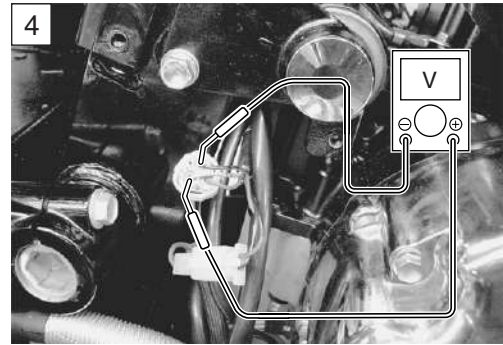

**Step 5**

- 1) If the position sensor output voltage is 0.5 V and less at fully close position, adjust the output voltage to specified by turning out the No. 1 cable adjuster ①.
- 2) Repeat the above procedure (Step 4) until the out put voltage becomes specified value. (If C46/P1657 code is indicated after adjusting the voltage, increase the voltage to 0.4 V.)

**CAUTION**

- \* Adjusting the cable with the EXCV fully opened or fully closed can damage the EXCVA. Be sure to adjust the cable with the EXCV set in adjustment position. (☞ 7-2)
- \* Do not turn the EXCVA pulley using the wrench.

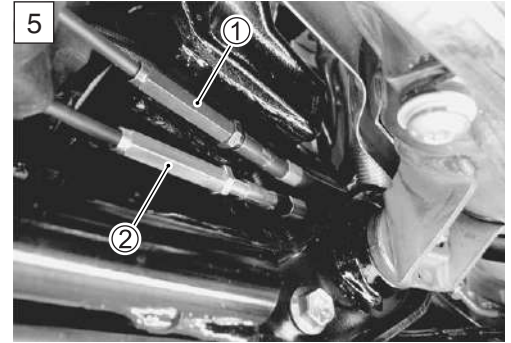

- 3) If the position sensor output voltage is 4.5 V and more at fully open position, adjust the output voltage to specified by turning out the No. 2 cable adjuster ②.  
Repeat the above procedure (Step 4) until the output voltage is within the specified value.

**DATA** Position sensor output voltage

**EXCV is fully close:  $0.5 \leq \text{Output Voltage} \leq 1.5$**

**EXCV is fully open :  $3.5 \leq \text{Output Voltage} \leq 4.5$**

Is the voltage OK?

YES	Replace the ECM with a known good one, and inspect it again.
NO	Replace the EXCVA with a new one.

- 3) After repairing the trouble, clear the DTC using SDS tool. (☞ 5-26)



**Step 6**

- 1) Turn the ignition switch OFF.
- 2) Disconnect the motor lead wire coupler of the EXCVA.



- 3) Apply 12 volts to the terminal and check the operation of EXCVA.

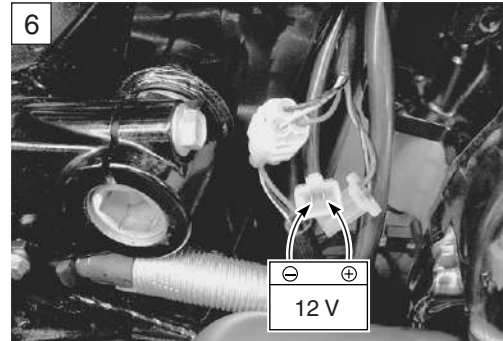

- 4) Then, swap the wires supplied 12 volts and check the operation of EXCVA.  
(Check the operation of EXCVA both way.)

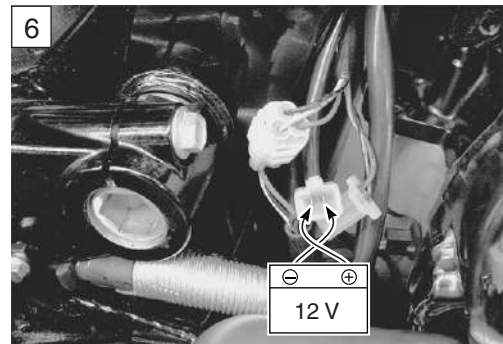

Is the operation OK?

YES	<ul style="list-style-type: none"> <li>• Loose or poor contacts on the EXCVA or ECM coupler (terminal ③ or ④)</li> <li>• Open or short circuit in the B/R wire or R/B wire</li> <li>• If wire and connection are OK, intermittent trouble or faulty ECM.</li> <li>• Recheck each terminal and wire harness for open circuit and poor connection.</li> <li>• Replace the ECM with a known good one, and inspect it again.</li> </ul>
NO	<ul style="list-style-type: none"> <li>• Replace the EXCVA with a new one.</li> <li>• Inspect that the EXCV and two cables move smoothly. (👉 7-3)</li> </ul>

- 5) After repairing the trouble, clear the DTC using SDS tool.  
(👉 5-26)



**ACTIVE CONTROL INSPECTION**

- 1) Set up the SDS tool. (Refer to the SDS operation manual for further details.)
- 2) Turn the ignition switch ON.
- 3) Click “Exhaust valve operating control” ①.

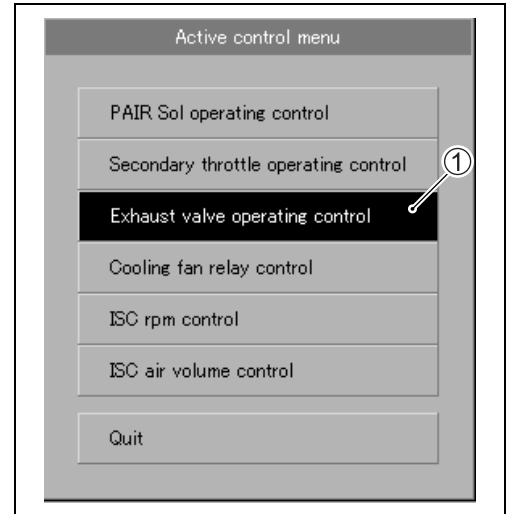

- 4) Click each button ②.  
At this time, if an operation sound is heard from the EXCVA, the function is normal.

<input type="checkbox"/>	Secondary throttle actuator position sensor	34.5	%
<input type="checkbox"/>	Exhaust control valve actuator position sens...	1.6	%
<input type="checkbox"/>	Exhaust valve full opened	Except full opn	
<input type="checkbox"/>	Exhaust valve full closed	Full closed	
<input type="checkbox"/>	Starter signal	Off	
<input type="checkbox"/>	Battery voltage	0.0	V
<input type="checkbox"/>	Exhaust valve control select terminal	GND	

## “C49” (P1768) or “C61” (P1656) PAIR CONTROL SOLENOID VALVE CIRCUIT MALFUNCTION

DETECTED CONDITION	POSSIBLE CAUSE
PAIR control solenoid valve voltage is not input to ECM.	<ul style="list-style-type: none"> <li>• PAIR control solenoid valve circuit open or short</li> <li>• PAIR control solenoid valve malfunction</li> <li>• ECM malfunction</li> </ul>

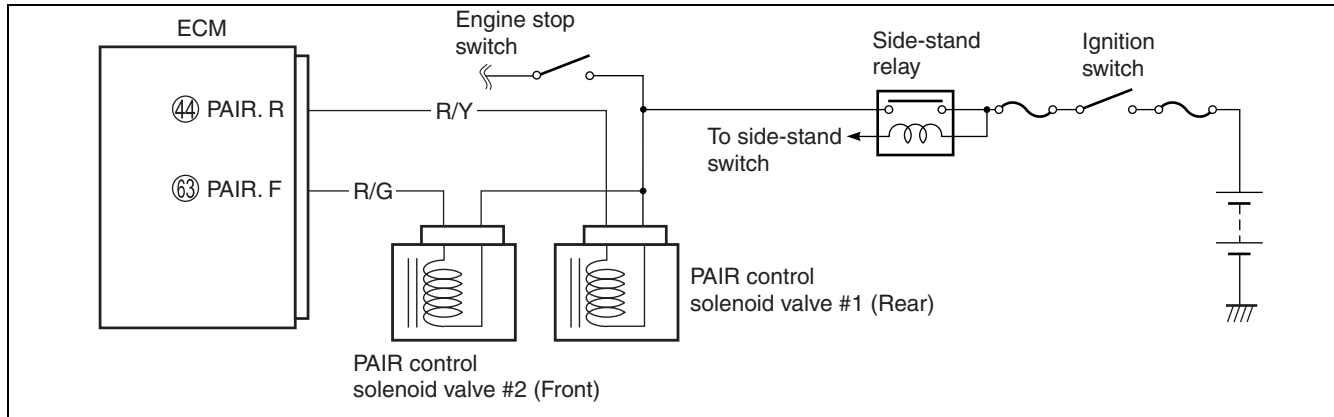

### INSPECTION

#### Step 1

(When indicating C49/P1768 for #2)

(When indicating C61/P1656 for #1)

- 1) Turn the ignition switch OFF.
- 2) Lift up the fuel tank. (☞ 6-3)
- 3) Check the PAIR control solenoid valve coupler for loose or poor contacts.  
If OK, then measure the PAIR control solenoid valve resistance.

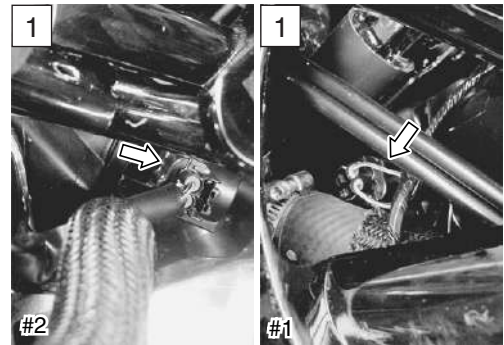

- 4) Disconnect the PAIR control valve coupler and measure the resistance between terminals.

**DATA** PAIR valve resistance: 18 – 22 Ω at 20 – 30 °C (68 – 86 °F)  
(Terminal – Terminal)

**TOOL** 09900-25008: Multi-circuit tester set

**Tester knob indication: Resistance (Ω)**

Is the resistance OK?

YES	Go to Step 2.
NO	Replace the PAIR valve with a new one.

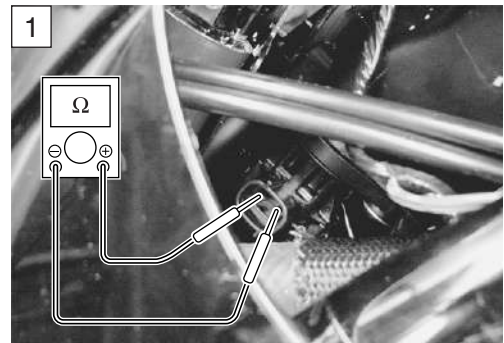

- 5) After repairing the trouble, clear the DTC using SDS tool. (☞ 5-26)

**Step 2**

- 1) Turn the ignition switch ON.
- 2) Measure the voltage between O/B wire and ground.

**DATA PAIR valve voltage: Battery voltage**  
 (+ O/B – – Ground)

**TOOL 09900-25008: Multi-circuit tester set**

**Tester knob indication: Voltage (V)**

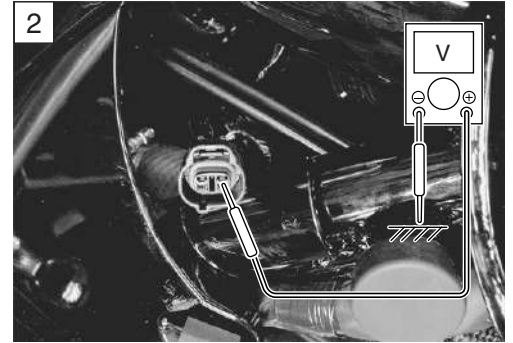

Is the voltage OK?

YES	<ul style="list-style-type: none"> <li>• W/G or R/G wire open or shorted to ground, or poor ④④ or ⑥③ connection failure.</li> <li>• If wire and connection are OK, intermittent trouble or faulty ECM.</li> <li>• Recheck each terminal and wire harness for open circuit and poor connection.</li> <li>• Replace the ECM with a known good one, and inspect it again.</li> </ul>
NO	Open or short circuit in the O/W wire.

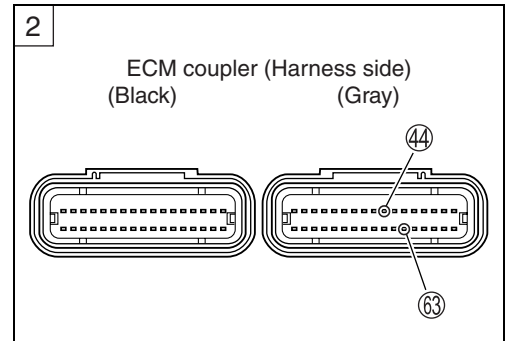

- 3) After repairing the trouble, clear the DTC using SDS tool. (5-26)

**ACTIVE CONTROL INSPECTION**

- 1) Set up the SDS tool. (Refer to the SDS operation manual for further details.)
- 2) Turn the ignition switch ON.
- 3) Click “PAIR Sol operating control” ①.

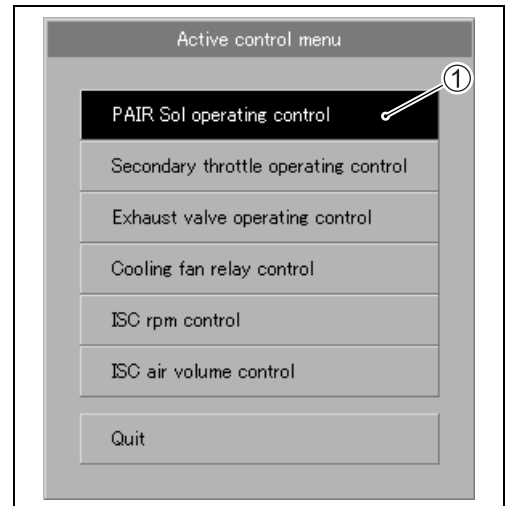

- 4) Click each button ②.

At this time, if an operation sound is heard from the PAIR control solenoid valve, the function is normal.

<table border="1" style="width: 100%;"> <tr><td><input type="checkbox"/> Gear position</td><td style="text-align: center;">N</td></tr> <tr><td><input type="checkbox"/> Cooling fan relay</td><td style="text-align: center;">Off</td></tr> <tr><td><input type="checkbox"/> PAIR control solenoid valve</td><td style="text-align: center;">On</td></tr> <tr><td><input type="checkbox"/> Ignition switch signal</td><td style="text-align: center;">Normal</td></tr> <tr><td><input type="checkbox"/> Tip over sensor</td><td style="text-align: center;">Off</td></tr> <tr><td><input type="checkbox"/> Neutral switch signal</td><td style="text-align: center;">GND</td></tr> <tr><td><input type="checkbox"/> Clutch switch signal</td><td style="text-align: center;">Off</td></tr> </table>	<input type="checkbox"/> Gear position	N	<input type="checkbox"/> Cooling fan relay	Off	<input type="checkbox"/> PAIR control solenoid valve	On	<input type="checkbox"/> Ignition switch signal	Normal	<input type="checkbox"/> Tip over sensor	Off	<input type="checkbox"/> Neutral switch signal	GND	<input type="checkbox"/> Clutch switch signal	Off	↔	
<input type="checkbox"/> Gear position	N															
<input type="checkbox"/> Cooling fan relay	Off															
<input type="checkbox"/> PAIR control solenoid valve	On															
<input type="checkbox"/> Ignition switch signal	Normal															
<input type="checkbox"/> Tip over sensor	Off															
<input type="checkbox"/> Neutral switch signal	GND															
<input type="checkbox"/> Clutch switch signal	Off															

## “C60” (P0480) COOLING FAN RELAY CIRCUIT MALFUNCTION

DETECTED CONDITION	POSSIBLE CAUSE
Cooling fan relay signal is not input to ECM.	<ul style="list-style-type: none"> <li>Cooling fan relay circuit open or short</li> <li>ECM malfunction</li> </ul>

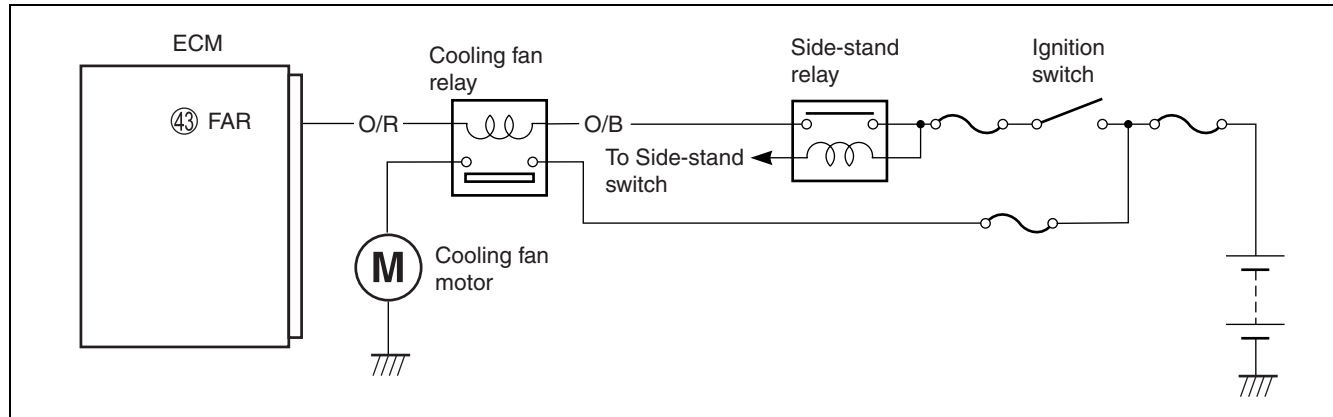

### INSPECTION

#### Step 1

- Turn the ignition switch OFF.
- Remove the right frame side cover. (🔧 9-5)
- Check the cooling fan relay coupler for loose or poor contacts.  
If OK, then inspection the cooling fan relay. (🔧 8-8)



Is the cooling fan relay OK?

YES	<ul style="list-style-type: none"> <li>O/B and O/R wire open or shorted to ground, or poor 43 connection</li> <li>If wire and connection are OK, intermittent trouble or faulty ECM.</li> <li>Recheck each terminal and wire harness for open circuit and poor connection.</li> <li>Replace the ECM with a known good one, and inspect it again.</li> </ul>
NO	Replace the cooling fan relay with a new one.

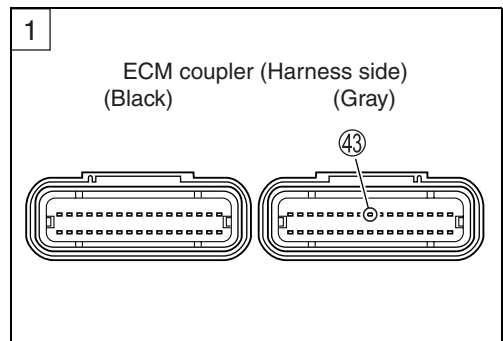

- After repairing the trouble, clear the DTC using SDS tool. (🔧 5-26)

**ACTIVE CONTROL INSPECTION**

- 1) Set up the SDS tool. (Refer to the SDS operation manual for further details.)
- 2) Start the engine and run it idling condition.
- 3) Click “Cooling fan relay control” ①.

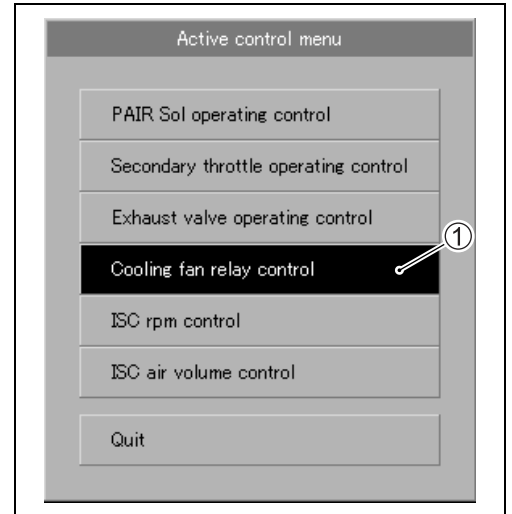

- 4) Click the operate button ②.

At this time, if an operation sound is heard from the cooling fan relay and cooling fan motor is operated, the function is normal.

**NOTE:**

Cooling fan relay and cooling fan motor operation can be checked until the engine coolant temperature is less than 100 °C (212 °F) after starting the engine.

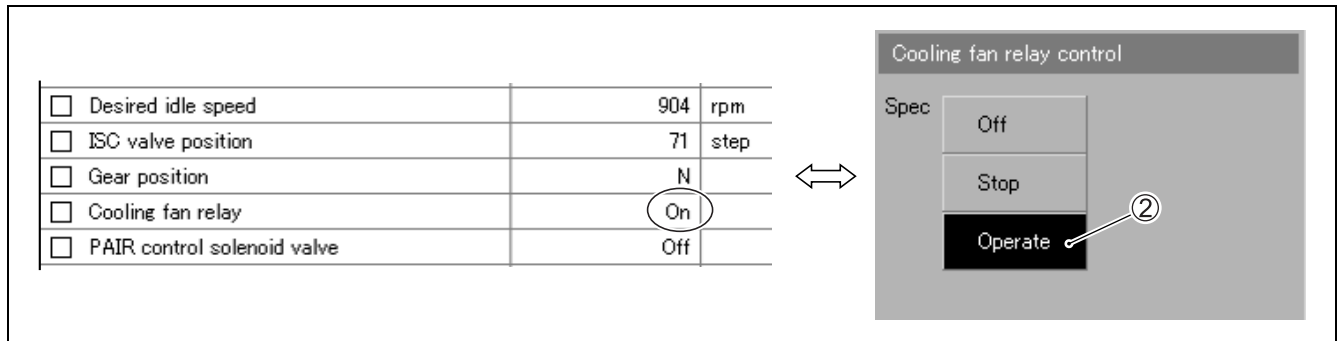

- 5) Click the stop button ③ to check the operation properly.

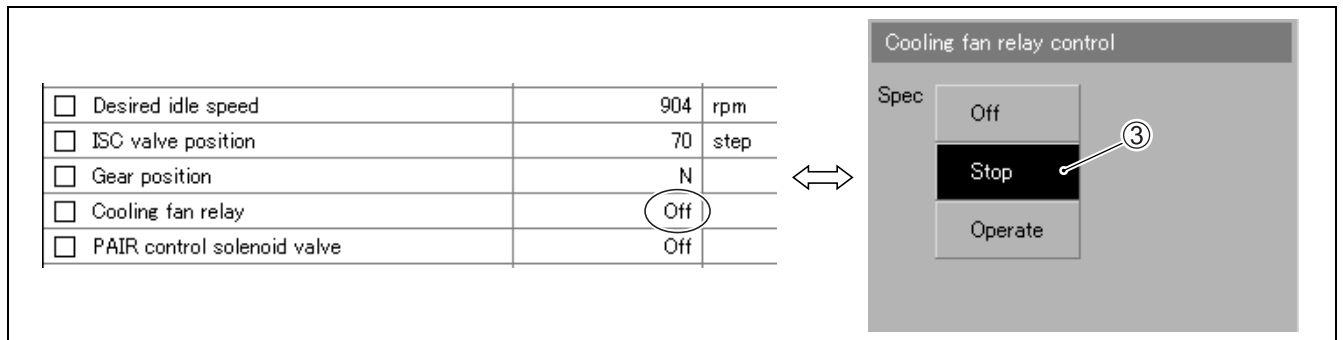

6) Click the off button ④ to check the cooling fan relay and cooling fan motor operation.

**NOTE:**

*This inspection should be begun from when the engine coolant temperature is below 50 °C (122 °F).*

*Check that the cooling fan relay operates for a few seconds as the engine coolant temperature arrives each at 50 °C (122 °F), 70 °C (158 °F) and 90 °C (194 °F) / above 4 000 r/min. It is cooling fan motor malfunction or its circuit failure when the motor would not run even if the relay turns to ON.*

**NOTE:**

*There is a tolerance of operating temperature of cooling fan relay.*

<input type="checkbox"/> Desired idle speed	904	rpm
<input type="checkbox"/> ISC valve position	65	step
<input type="checkbox"/> Gear position	N	
<input type="checkbox"/> Cooling fan relay	On	
<input type="checkbox"/> PAIR control solenoid valve	On	



Cooling fan relay control

Spec

Off ④

Stop

Operate



## SENSORS

### IAP SENSOR INSPECTION

The intake air pressure sensor is located at the right and left side of the air cleaner box. (👉 6-13)

### IAP SENSOR REMOVAL AND INSTALLATION

- Remove the fuel tank. (👉 6-3)
- Remove the IAP sensors from the air cleaner chamber.
- Install the IAP sensors in the reverse order of removal.

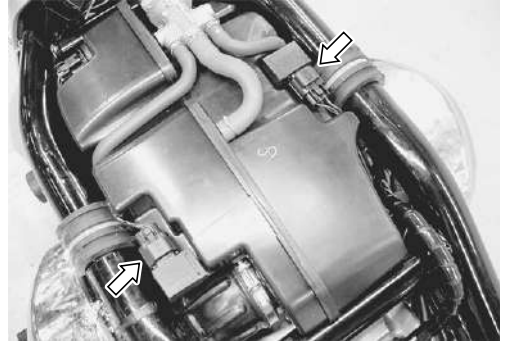

### TP SENSOR INSPECTION

The throttle position sensor is installed on the No. 2 throttle body. (👉 5-41)

### TP SENSOR REMOVAL AND INSTALLATION

- Remove the fuel tank. (👉 6-3)
- Remove the right air cleaner box. (👉 6-13)
- Remove the TP sensor and disconnect the coupler ①.

 **09930-11950: Torx wrench**

- Install the TP sensor to the No. 2 throttle body. (👉 6-19)

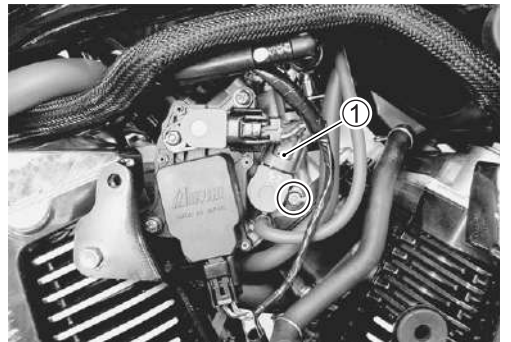

### TPS ADJUSTMENT

- Adjust the TP sensor. (👉 5-20)

## STP SENSOR INSPECTION

The secondary throttle position sensor is installed on the No. 2 throttle body. (☞ 5-61)

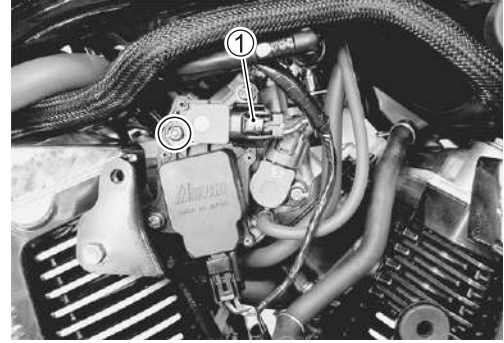

## STP SENSOR REMOVAL AND INSTALLATION

- Remove the fuel tank. (☞ 6-3)
- Remove the right air cleaner box. (☞ 6-13)
- Remove the STP sensor and disconnect the coupler ①.

**TOOL** 09930-11950: Torx wrench

- Install the STP sensor to the No. 2 throttle body. (☞ 6-19)

## STP SENSOR ADJUSTMENT

- Adjust the STP sensor. (☞ 6-22)

## CKP SENSOR INSPECTION

The signal rotor is mounted on the generator rotor and crankshaft position sensor is installed at the inside of the generator cover. (☞ 4-32)



## CKP SENSOR REMOVAL AND INSTALLATION

- Remove the generator cover. (☞ 3-18)
- Remove the CKP sensor.
- Install the CKP sensor in the reverse order of removal. (☞ 3-50)

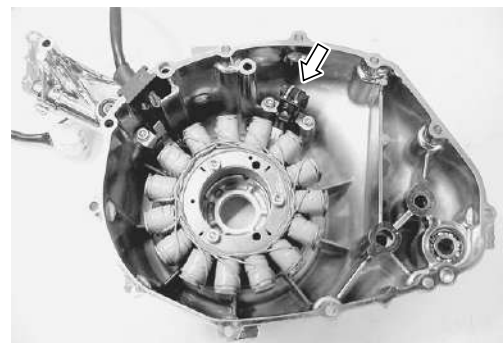

## IAT SENSOR INSPECTION

The intake air temperature sensor is installed at the front left side of the air cleaner box. (☞ 5-50)

## IAT SENSOR REMOVAL AND INSTALLATION

- Remove the fuel tank. (☞ 6-3)
- Remove the IAT sensor from the air cleaner chamber.
- Install the IAT sensor in the reverse order of removal.



## ECT SENSOR INSPECTION

The engine coolant temperature sensor is installed at the thermostat body. (☞ 5-46)

## ECT SENSOR REMOVAL AND INSTALLATION

- Remove the right air cleaner box. (☞ 6-13)
- Remove the ECT sensor from the thermostat body.
- Install the ECT sensor in the reverse order of removal.

 **ECT sensor: 18 N·m (1.8 kgf-m, 13.0 lb-ft)**

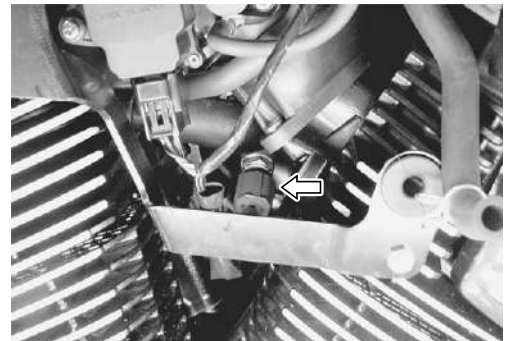

## TO SENSOR INSPECTION

The tip-over sensor is located under the front seat. (☞ 5-54)

## TO SENSOR REMOVAL AND INSTALLATION

- Remove the right frame side cover. (☞ 9-5)
- Remove the TO sensor.
- Install the TO sensor in the reverse order of removal.

### NOTE:

When installing the TO sensor, the arrow mark  must be pointed upward.

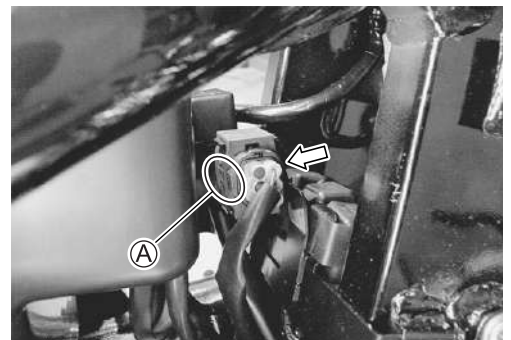

## HO2 SENSOR INSPECTION (FOR E-02, 19, 24)

The heated oxygen sensor is installed on the pre-muffler.  
( 5-79)

## HO2 SENSOR REMOVAL AND INSTALLATION (FOR E-02, 19, 24)

- Remove the HO2 sensor unit.

### WARNING

Do not remove the HO2 sensor while it is hot.

### CAUTION

- \* Be careful not to expose it to excessive shock.
- \* Do not use an impact wrench while removing or installing the HO2 sensor unit.
- \* Be careful not to twist or damage the sensor lead wire.

- Install the HO2 sensor in the reverse order of removal.

### CAUTION

Do not apply oil or other materials to the sensor air hole.

- Tighten the sensor unit to the specified torque.

 HO2 SENSOR: 48 N·m (4.8 kgf-m, 34.5 lb-ft)



# FUEL SYSTEM AND THROTTLE BODY

## CONTENTS

<b>FUEL DELIVERY SYSTEM.....</b>	<b>6- 2</b>
<b>FUEL SYSTEM.....</b>	<b>6- 3</b>
<b>FUEL TANK REMOVAL.....</b>	<b>6- 3</b>
<b>FUEL TANK INSTALLATION.....</b>	<b>6- 3</b>
<b>FUEL PRESSURE INSPECTION.....</b>	<b>6- 4</b>
<b>FUEL PUMP INSPECTION.....</b>	<b>6- 5</b>
<b>FUEL DISCHARGE AMOUNT INSPECTION.....</b>	<b>6- 5</b>
<b>FUEL PUMP RELAY INSPECTION.....</b>	<b>6- 6</b>
<b>FUEL PUMP AND FUEL LEVEL GAUGE REMOVAL.....</b>	<b>6- 7</b>
<b>FUEL LEVEL GAUGE INSPECTION.....</b>	<b>6- 8</b>
<b>FUEL PUMP DISASSEMBLY.....</b>	<b>6- 9</b>
<b>FUEL MESH FILTER INSPECTION.....</b>	<b>6-10</b>
<b>FUEL PUMP AND FUEL LEVEL GAUGE REASSEMBLY AND     INSTALLATION.....</b>	<b>6-10</b>
<b>THROTTLE BODY.....</b>	<b>6-12</b>
<b>CONSTRUCTION.....</b>	<b>6-12</b>
<b>AIR CLEANER BOX REMOVAL.....</b>	<b>6-13</b>
<b>AIR CLEANER BOX INSTALLATION.....</b>	<b>6-13</b>
<b>AIR CLEANER CHAMBER AND THROTTLE BODY REMOVAL.....</b>	<b>6-13</b>
<b>THROTTLE BODY DISASSEMBLY.....</b>	<b>6-15</b>
<b>THROTTLE BODY CLEANING.....</b>	<b>6-17</b>
<b>INSPECTION.....</b>	<b>6-17</b>
<b>ISC VALVE INSPECTION.....</b>	<b>6-17</b>
<b>ISC VALVE REMOVAL.....</b>	<b>6-18</b>
<b>INSPECTION.....</b>	<b>6-18</b>
<b>ISC VALVE INSTALLATION.....</b>	<b>6-18</b>
<b>THROTTLE BODY REASSEMBLY.....</b>	<b>6-19</b>
<b>AIR CLEANER CHAMBER AND THROTTLE BODY INSTALLATION.....</b>	<b>6-21</b>
<b>STP SENSOR ADJUSTMENT.....</b>	<b>6-22</b>
<b>FUEL INJECTOR REMOVAL.....</b>	<b>6-22</b>
<b>FUEL INJECTOR INSPECTION.....</b>	<b>6-22</b>
<b>FUEL INJECTOR INSTALLATION.....</b>	<b>6-23</b>
<b>THROTTLE VALVE SYNCHRONIZATION.....</b>	<b>6-23</b>
<b>THROTTLE POSITION SENSOR (TPS) SETTING.....</b>	<b>6-24</b>

### **▲ WARNING**

Gasoline must be handled carefully in an area well ventilated and away from fire or sparks.

## FUEL DELIVERY SYSTEM

The fuel delivery system consists of the fuel tank, fuel pump, fuel filters, fuel feed hose, fuel delivery pipe (including fuel injectors) and fuel pressure regulator. There is no fuel return hose. The fuel in the fuel tank is pumped up by the fuel pump and pressurized fuel flows into the injector installed in the fuel delivery pipe. Fuel pressure is regulated by the fuel pressure regulator. As the fuel pressure applied to the fuel injector (the fuel pressure in the fuel delivery pipe) is always kept at absolute fuel pressure of 3.0 kgf/cm<sup>2</sup> (300 kPa, 43 psi), the fuel is injected into the throttle body in conic dispersion when the injector opens according to the injection signal from the ECM.

The fuel relieved by the fuel pressure regulator flows back to the fuel tank.

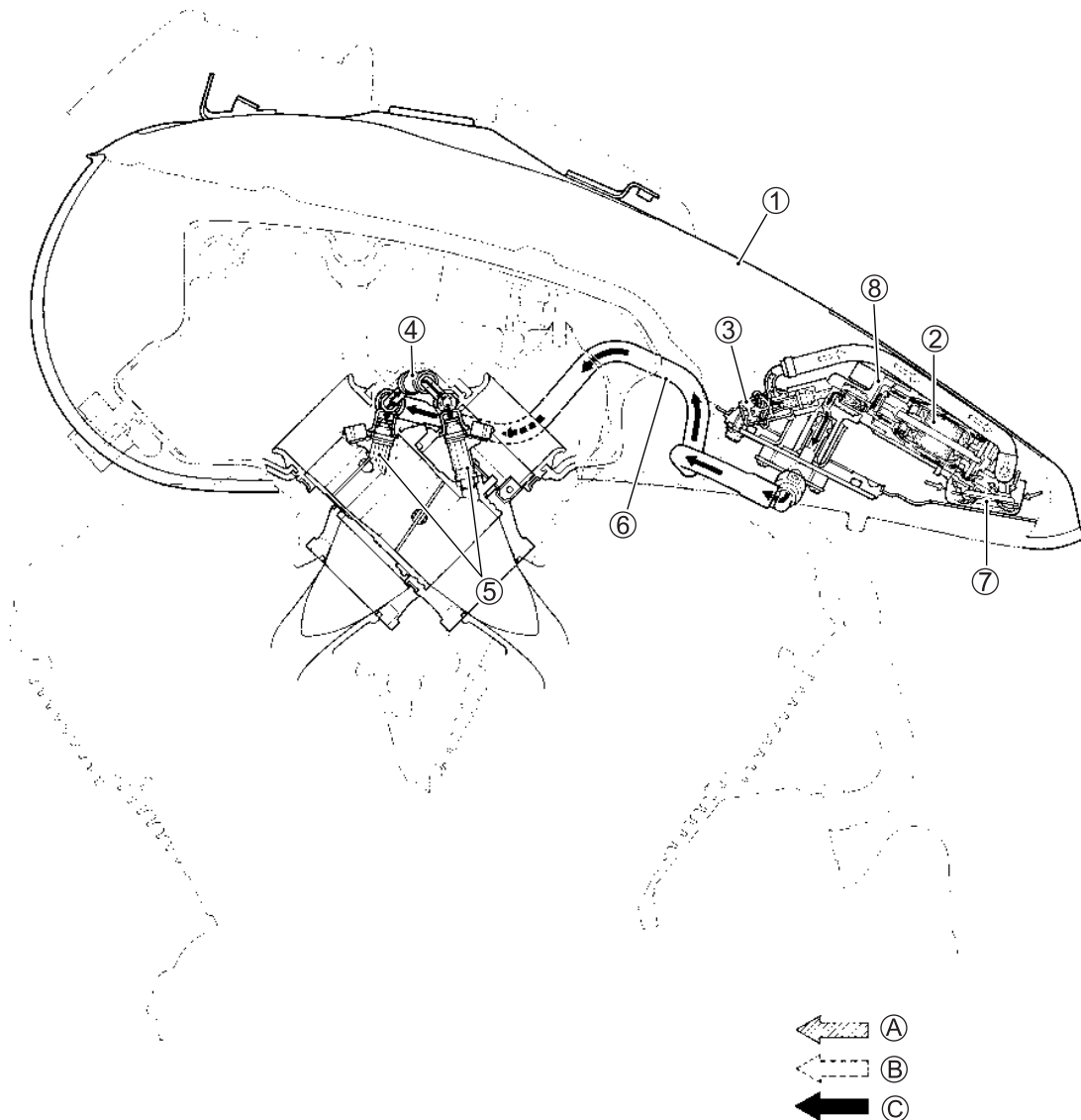

①	Fuel tank	⑦	Fuel mesh filter (For low pressure)
②	Fuel filter (For high pressure)	⑧	Fuel pump
③	Fuel pressure regulator	(A)	Before-pressurized fuel
④	Fuel delivery pipe	(B)	Relieved fuel
⑤	Fuel injector	(C)	Pressurized fuel
⑥	Fuel feed hose		



## FUEL SYSTEM

### FUEL TANK REMOVAL

- Remove the left and right frame side covers. (☞ 9-5)
- Remove the fuel tank mounting bolt.



- Lift and support the fuel tank about 10 cm (3.94 in) with the proper stay.

#### NOTE:

*Be careful not to lift the fuel more than about 10 cm (3.94 in), or hoses will be twisted.*

- Disconnect the fuel pump lead wire coupler ①.
- Place a rag under the fuel feed hose and disconnect the fuel feed hose ②.

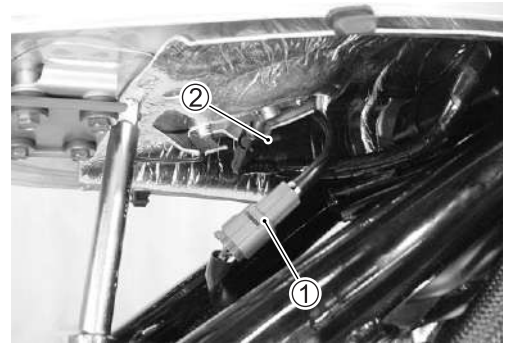

#### CAUTION

**When removing the fuel tank, do not leave the fuel feed hose ② on the fuel tank side.**

#### ⚠ WARNING

**Gasoline is highly flammable and explosive.  
Keep heat, spark and flame away.**

- Disconnect the speedometer coupler ③.
- Remove the fuel tank.

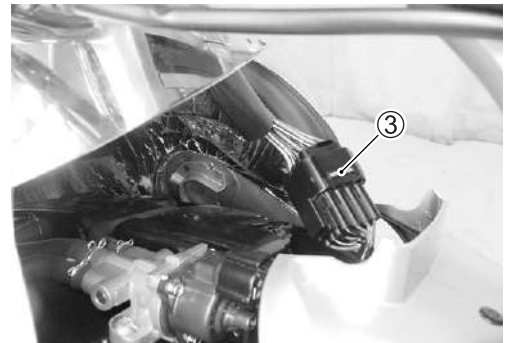

### FUEL TANK INSTALLATION

- Installation is in the reverse order of removal.

## FUEL PRESSURE INSPECTION

- Lift and support the fuel tank. (☞ 6-3)
- Place a rag under the fuel feed hose.
- Disconnect the fuel feed hose ①.

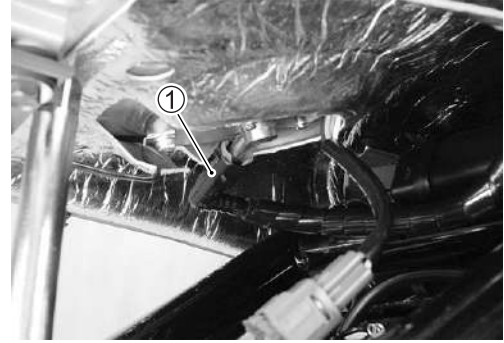

- Install the special tools between the fuel tank and fuel delivery pipe.

**TOOL** 09940-40211: Fuel pressure gauge adaptor  
 09940-40220: Fuel pressure gauge hose attachment  
 09915-74511: Oil pressure gauge hose

Turn the ignition switch ON and check the fuel pressure.

**DATA** Fuel pressure: Approx. 300 kPa (3.0 kgf/cm<sup>2</sup>, 43 psi)

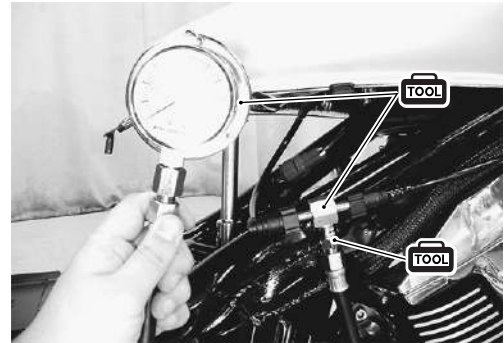

If the fuel pressure is lower than the specification, inspect the following items:

- \* Clogged fuel filter
- \* Pressure regulator
- \* Fuel pump
- \* Fuel hose leakage

If the fuel pressure is higher than the specification, inspect the following items:

- \* Fuel pump check valve
- \* Pressure regulator

### ⚠ WARNING

- \* Before removing the special tools, turn the ignition switch to OFF position and release the fuel pressure slowly.
- \* Gasoline is highly flammable and explosive. Keep heat, sparks and flame away.

Ⓐ To fuel tank

Ⓑ To fuel delivery pipe

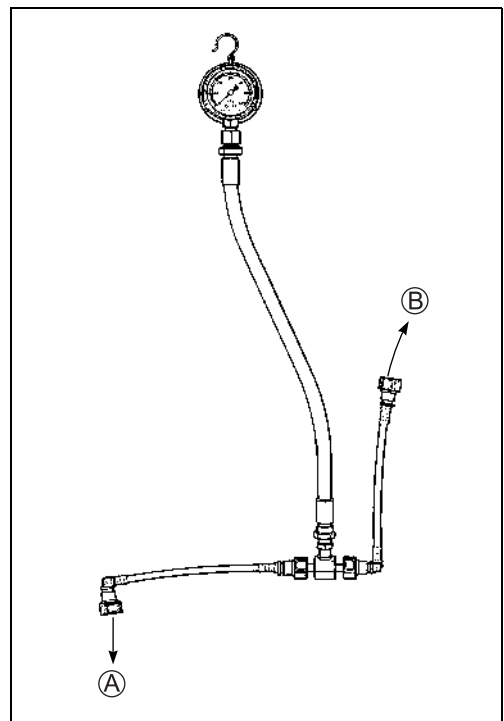

## FUEL PUMP INSPECTION

Turn the ignition switch ON and check that the fuel pump operates for few seconds.

If the fuel pump motor does not make operating sound, inspect the fuel pump circuit connections or inspect the fuel pump relay and tip-over sensor.

If the fuel pump relay, tip-over sensor and fuel pump circuit connections are OK, the fuel pump may be faulty, replace the fuel pump with a new one.

## FUEL DISCHARGE AMOUNT INSPECTION

### ⚠ WARNING

**Gasoline is highly flammable and explosive.  
Keep heat, spark and flame away.**

- Lift and support the fuel tank. (☞ 6-3)
- Place a rag under the fuel feed hose and disconnect the fuel feed hose ① from the fuel delivery pipe.
- Place the measuring cylinder and insert the fuel feed hose end into the measuring cylinder.



- Disconnect the fuel pump lead wire coupler ②.



- Connect a proper lead wire into the fuel pump lead wire coupler (fuel pump side) and apply 12 volts to the fuel pump (between Y/R wire and B/W wire) for 10 seconds and measure the amount of fuel discharged.

Battery ⊕ terminal ——— (Yellow with red tracer)

Battery ⊖ terminal ——— (Black with white tracer)

If the pump does not discharge the amount specified, it means that the fuel pump is defective or that the fuel filter is clogged.

**DATA** Fuel discharge amount:

**168 ml (5.7/5.9 US/Imp oz) and more/10 sec.**

**NOTE:**

*The battery must be in fully charged condition.*

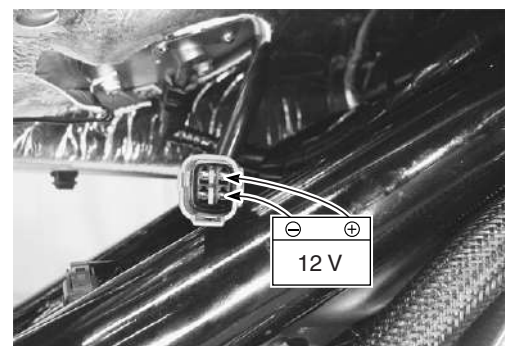

## FUEL PUMP RELAY INSPECTION

Cooling fan relay is located in front of the battery.

- Remove the right side frame cover. (☞ 9-5)
- Remove the fuel pump relay ①.

First check the insulation between (A) and (B) terminals with tester. Then apply 12 V to (C) and (D) terminals, + to (C) and - to (D), and check the continuity between (A) and (B).

If there is no continuity, replace it with a new one.

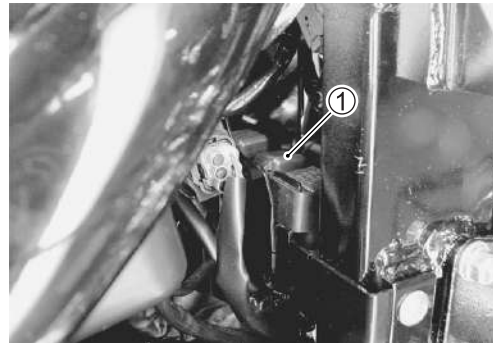

 **09900-25008: Multi-circuit tester set**

 **Tester knob indication: Continuity test (•••)**

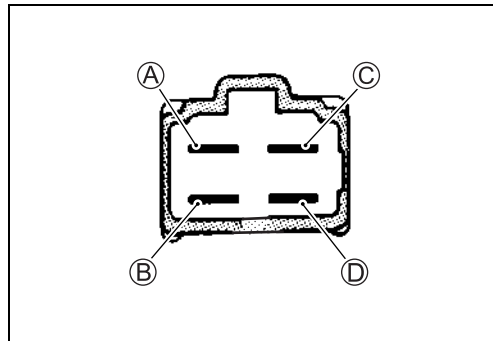

## FUEL PUMP AND FUEL LEVEL GAUGE REMOVAL CONSTRUCTION

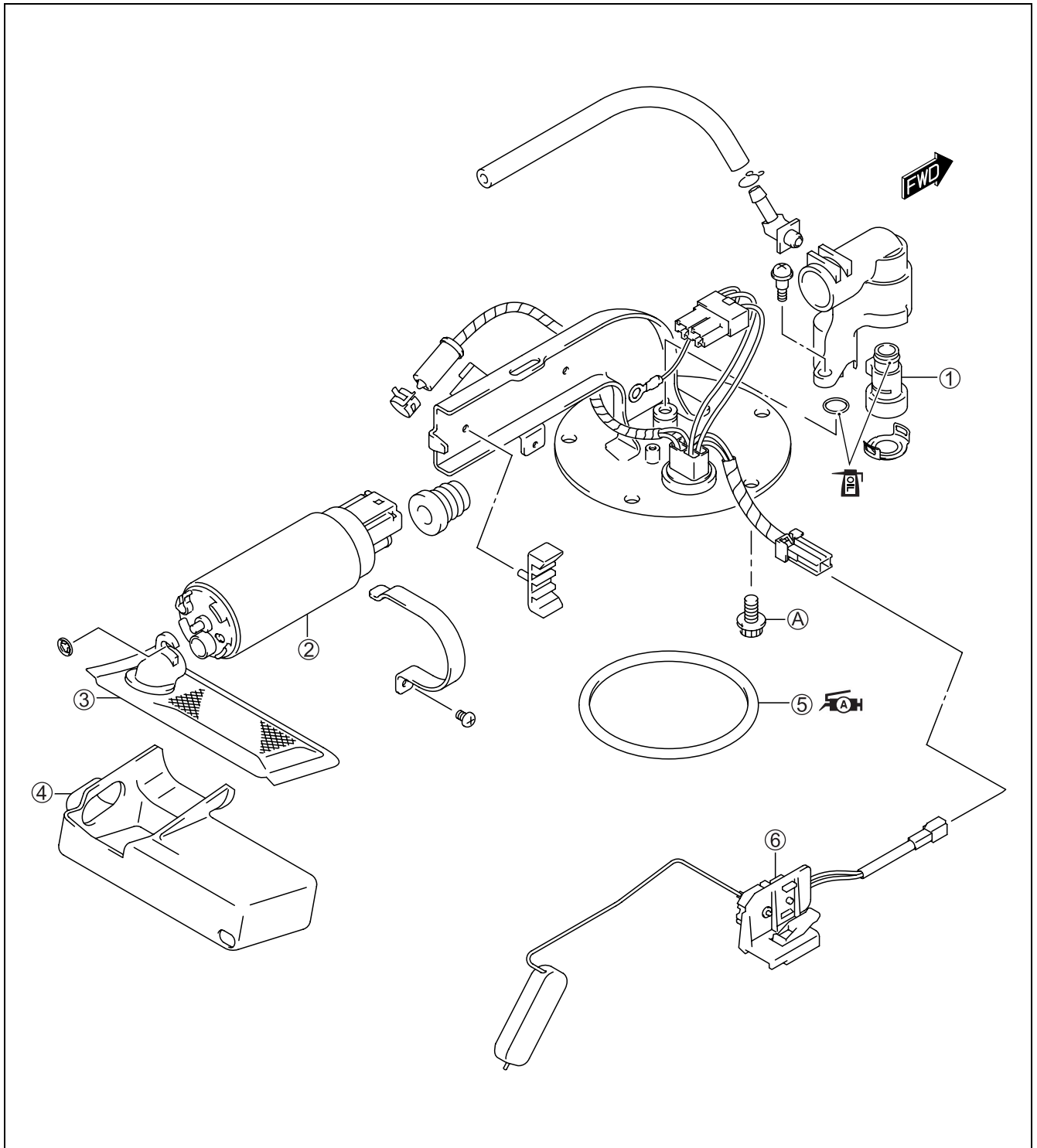

①	Thermistor	⑤	O-ring
②	Fuel pump	⑥	Fuel level gauge
③	Fuel mesh filter	Ⓐ	Fuel pump mounting bolt
④	Filter cover		



ITEM	N·m	kgf·m	lb·ft
Ⓐ	10	1.0	7.0

## REMOVAL

- Remove the fuel tank. (☞ 6-3)
- Remove the fuel tank shield ①.

Ⓐ: Clamp

- Remove the fuel pump assembly ② mounting bolts diagonally.

### ⚠ WARNING

**Gasoline is highly flammable and explosive.  
Keep heat, spark and flame away.**

- Remove the fuel pump assembly and disconnect the fuel gauge lead wire coupler ③.

- Remove the fuel level gauge ④ while pushing the pawl end Ⓐ.

### CAUTION

**Do not pull the lead wire when removing the fuel gauge.**

## FUEL LEVEL GAUGE INSPECTION

(☞ 10-36)

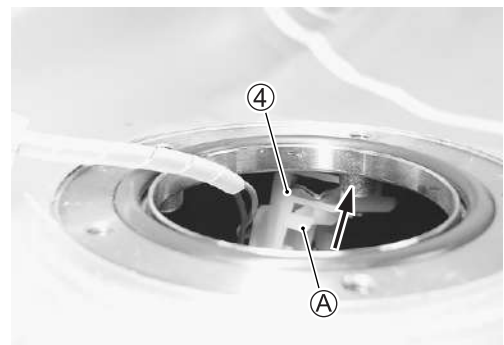
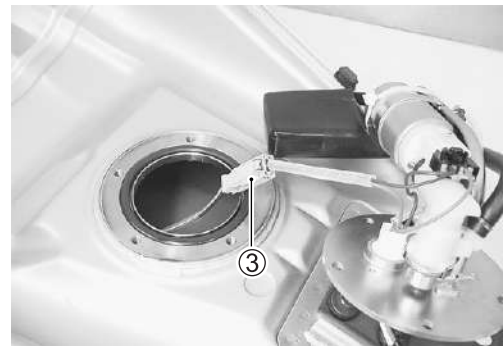
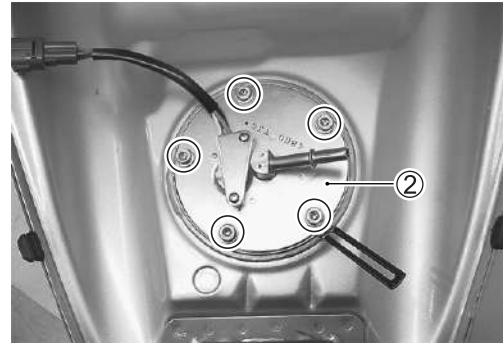
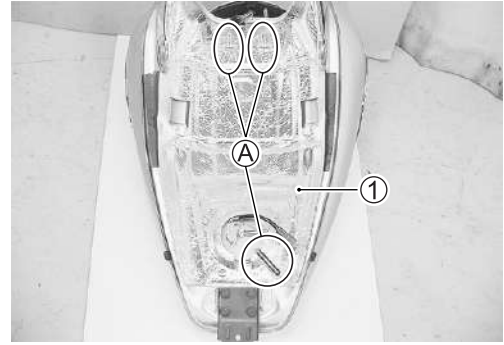



## FUEL PUMP DISASSEMBLY

- Disconnect the fuel pump coupler ①.
- Remove the band ② and clamp ③.
- Remove the hose ④ and filter cover ⑤.
- Remove the clamp ⑥ and thermistor ⑦.
- Remove the fuel mesh filter ⑧.
- Remove the fuel pump ⑨.
- Remove the clip ⑩ and pressure regulator ⑪.
- Remove the bushing ⑫.

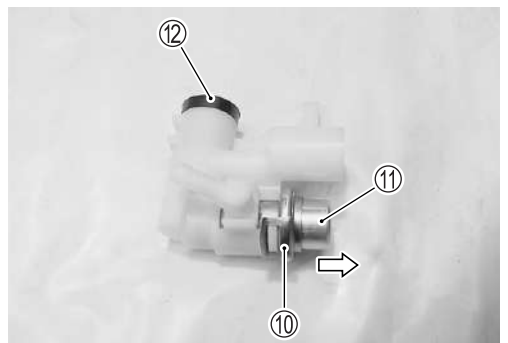
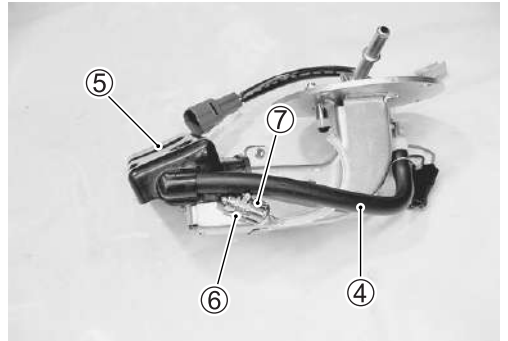
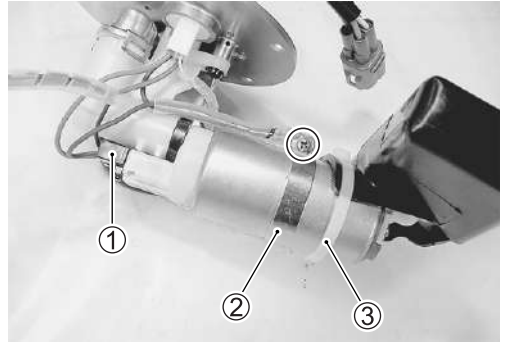

## FUEL MESH FILTER INSPECTION

- Disconnect the clamp ① and rubber boot ②.
- If the fuel mesh filter is clogged with sediment or rust, replace the fuel filter with a new one.



## FUEL PUMP AND FUEL LEVEL GAUGE REASSEMBLY AND INSTALLATION

Install the fuel pump and fuel level gauge in the reverse order of removal and disassembly. Pay attention to the following points:

- Apply thin coat of engine oil to the new bushing and install it to the fuel joint pipe.

### CAUTION

**Use the new bushing to prevent fuel leakage.**

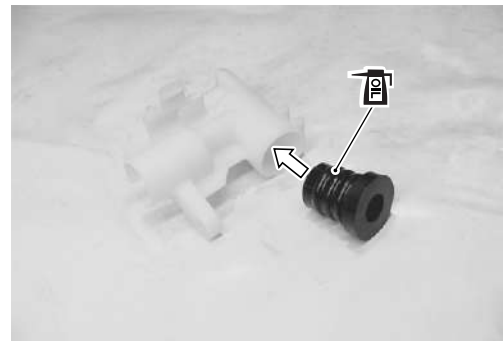

- Install the new O-ring to the pressure regulator.
- Apply thin coat of the engine oil to the new O-ring.

### CAUTION

**Use the new O-ring to prevent fuel leakage.**

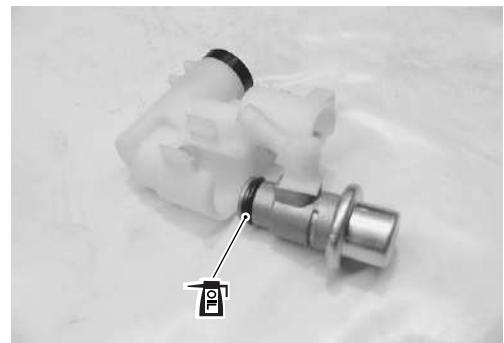

- Install the new O-ring to the fuel pipe.
- Apply thin coat of the engine oil to the new O-ring.

### CAUTION

**Use the new O-ring to prevent fuel leakage.**

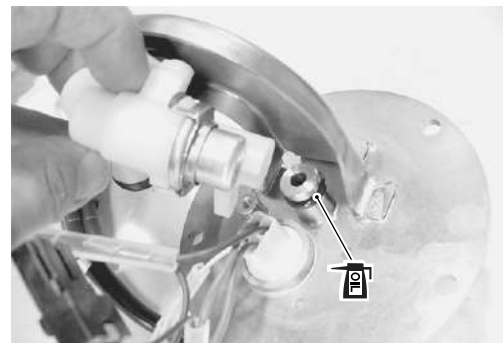

- Apply thin coat of the engine oil to the bushing.
- Install the fuel pump ①.

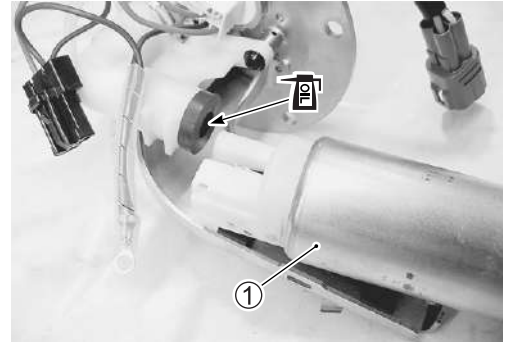

- Install a new O-ring and apply SUZUKI SUPER GREASE "A" to it.

 99000-25010: SUZUKI SUPER GREASE "A"  
or equivalent

**⚠ WARNING**

The O-ring must be replaced with a new one to prevent fuel leakage.



- When installing the fuel pump assembly, first tighten all the fuel pump mounting bolts lightly and then to the specified torque as shown.

 Fuel pump mounting bolt: 10 N·m (1.0 kgf-m, 7.0 lb-ft)

NOTE:

Fit the clamp bolt (A).

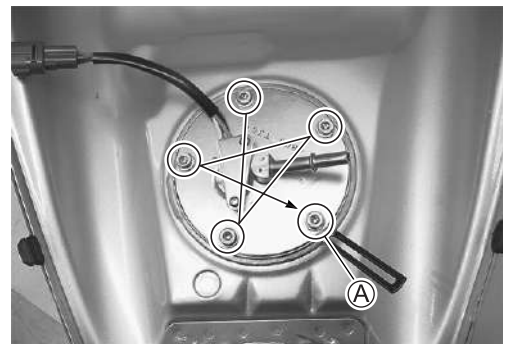

# THROTTLE BODY CONSTRUCTION

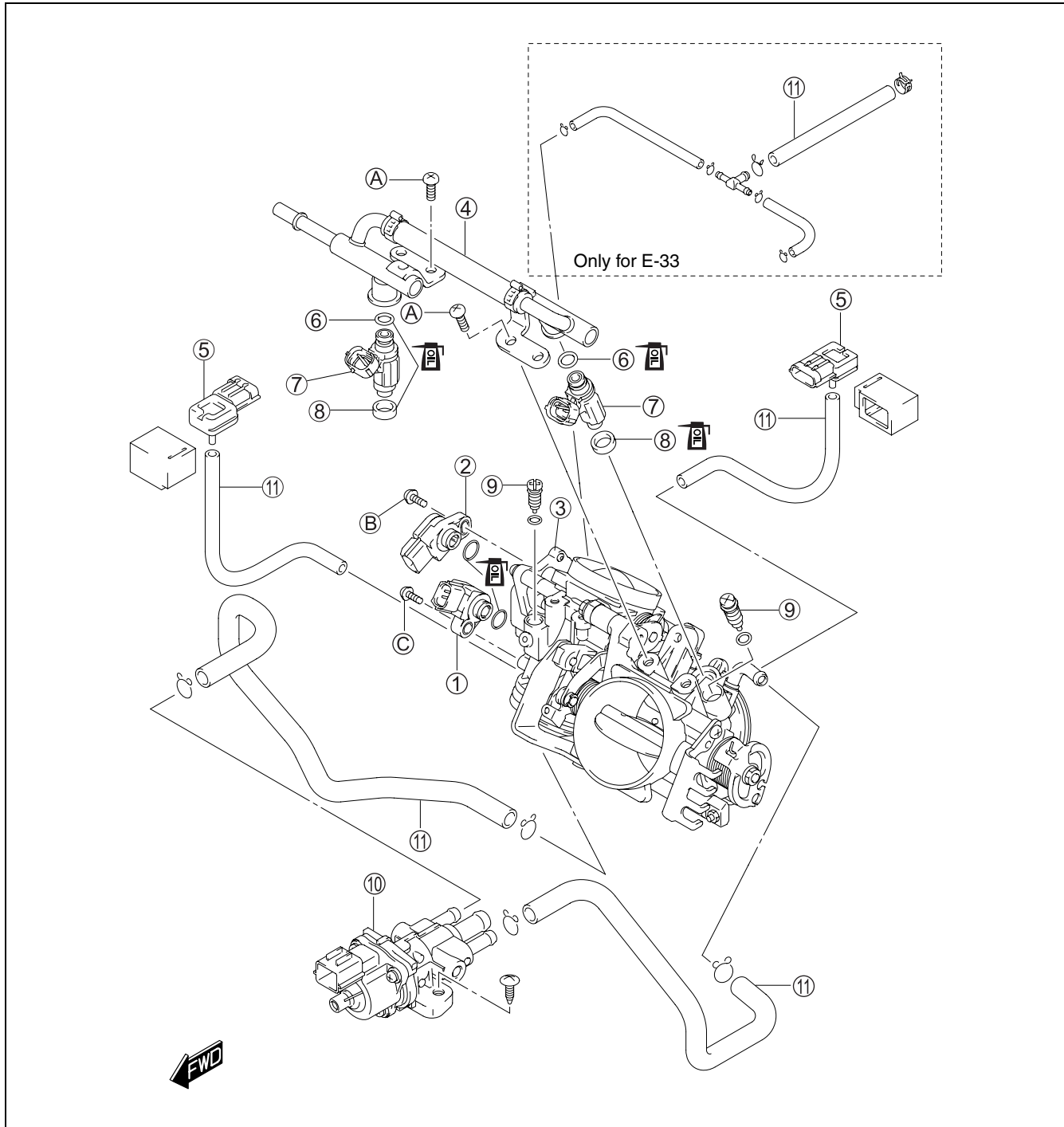

①	TP sensor	⑧	Cushion seal
②	STP sensor	⑨	Air screw
③	STVA	⑩	ISC valve
④	Fuel delivery pipe	⑪	Vacuum hose
⑤	IAP sensor	A	Fuel delivery pipe mounting screw
⑥	O-ring	B	STP sensor mounting screw
⑦	Fuel injector	C	TP sensor mounting screw

ITEM	N·m	kgf·m	lb·ft
A	5	0.5	3.5
B	3.5	0.35	2.5
C	3.5	0.35	2.5

## AIR CLEANER BOX REMOVAL

- Remove the fuel tank. (☞ 6-3)
- Remove the bolts.

☆: Hooked part

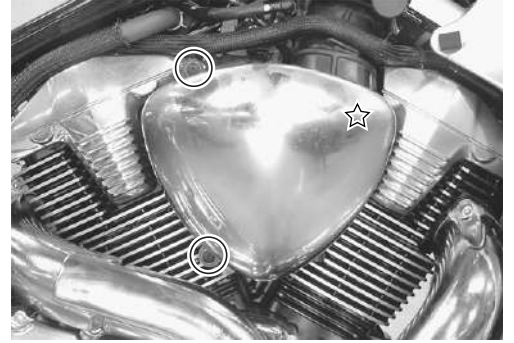

- Disconnect the drain hose ①.
- Loosen the clamp screw ②.
- Remove the right air cleaner box.

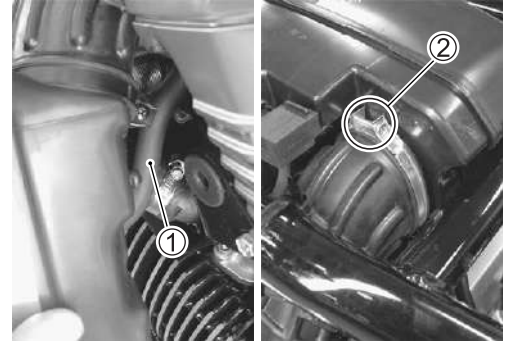

- Remove the bolts.

☆: Hooked part

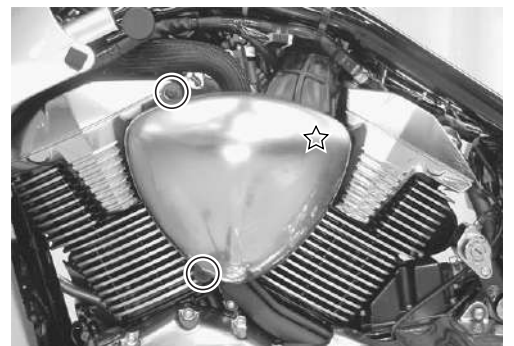

- Disconnect the drain hose ③.
- Loosen the clamp screw ④.
- Remove the left air cleaner box.

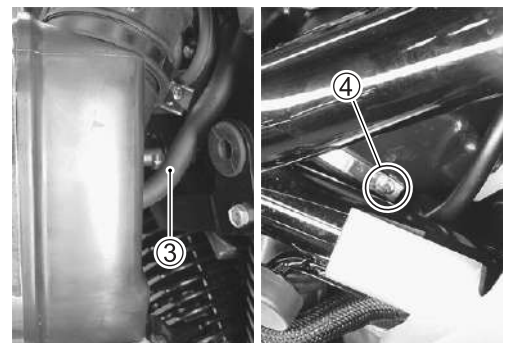

## AIR CLEANER BOX INSTALLATION

Installation is in the reverse order of removal.

## AIR CLEANER CHAMBER AND THROTTLE BODY REMOVAL

- Remove the air cleaner box. (☞ above)
- Remove the IAP sensors (Front cylinder side ① and Rear cylinder side ②) from the mount stay and vacuum hoses.
- Disconnect the IAT sensor ③ and ISC valve lead wire coupler ④.
- Disconnect the ISC valve hoses. (Front cylinder side ⑤, Rear cylinder side ⑥ and air cleaner chamber side ⑦)

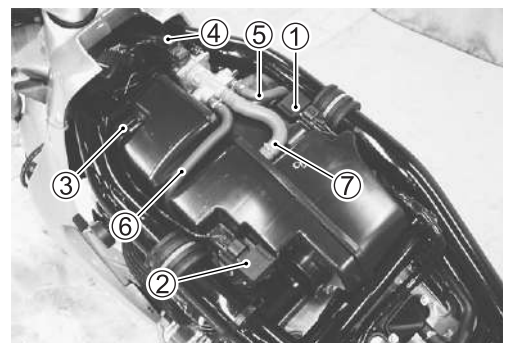



- Disconnect the PCV hose ⑧.



- Loosen the throttle body clamp screws at the air cleaner chamber side.

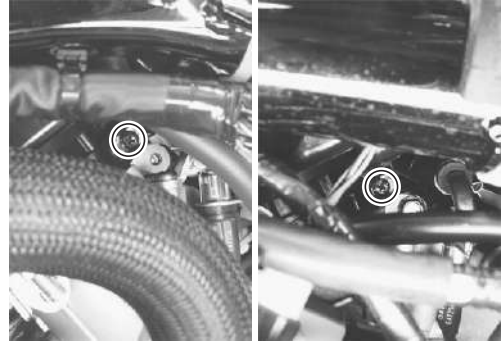

- Disconnect the PAIR lead wire couplers ⑨ and hoses ⑩.
- Remove the air cleaner chamber.

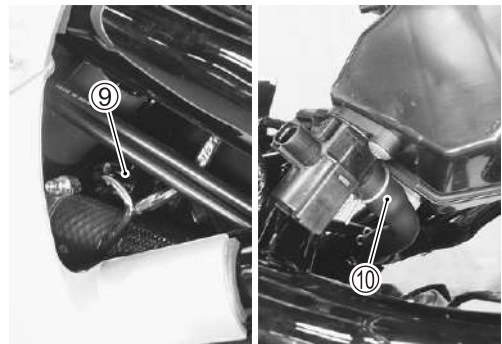

For E-03, 28, 33

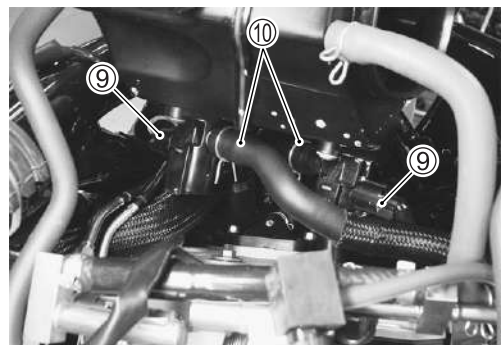

For the others

- Disconnect the STVA lead wire coupler ⑪, STP sensor lead wire coupler ⑫ and TP sensor lead wire coupler ⑬.

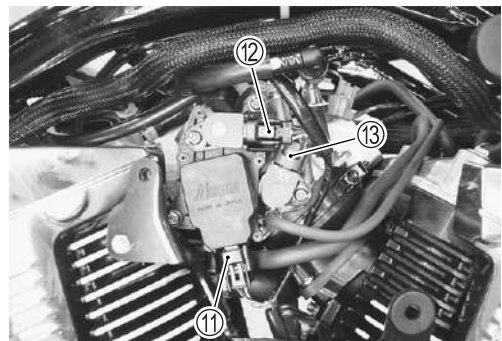



- Disconnect the clamp and fuel injector lead wire couplers ⑭.

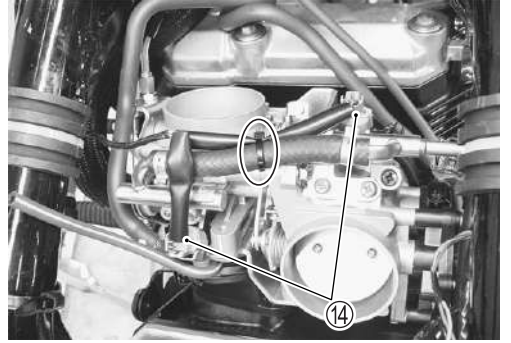

- Loosen the throttle body clamp screws at the intake pipe side.

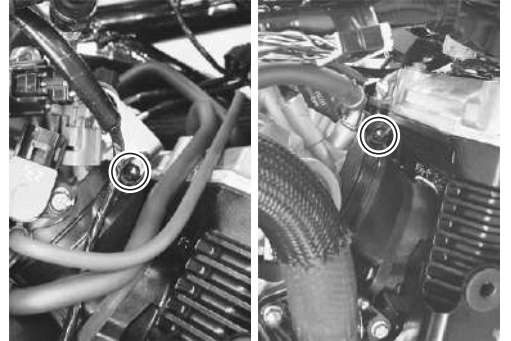

- Disconnect the throttle cables from their drum.
- Remove the throttle body assembly.

**CAUTION**

**Do not snap the throttle valve from full open to full close after disconnecting the throttle cables. It may cause damage to the throttle valve and throttle body.**

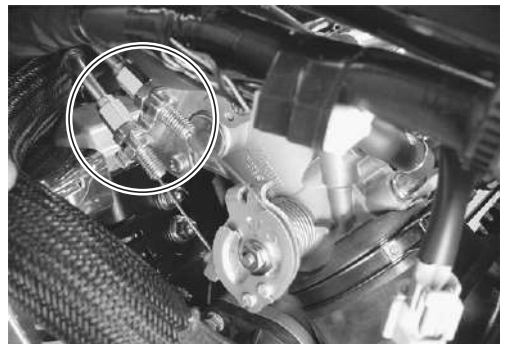

**THROTTLE BODY DISASSEMBLY**

- Disconnect the IAP sensor vacuum hoses ①, ISC valve hoses ② and fuel feed hoses ③.

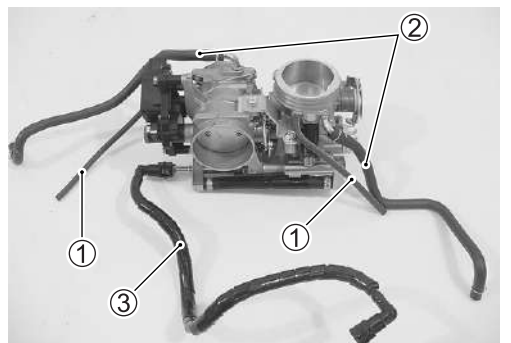

- Remove the fuel delivery pipes and hose assembly ④.

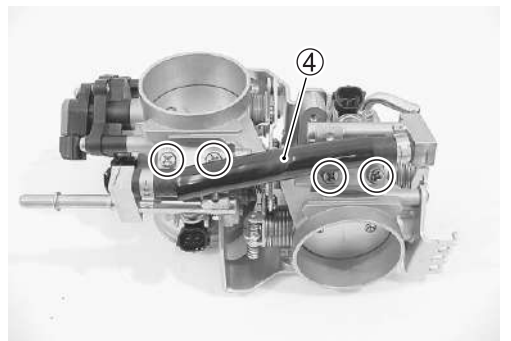

- Remove the fuel injectors ⑤.

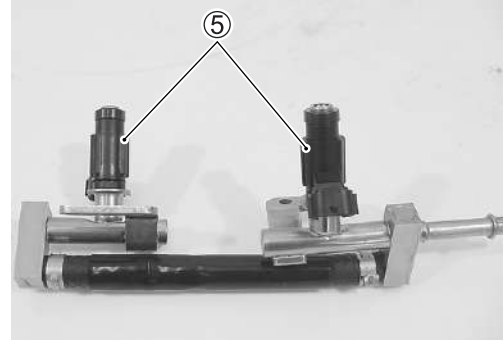

- Remove the TP sensor ⑥ and STP sensor ⑦ with the special tool.

**TOOL** 09930-11950: Torx wrench

**NOTE:**

*Prior to disassembly, mark each sensor's original position with a paint or scribe for accurate reinstallation.*

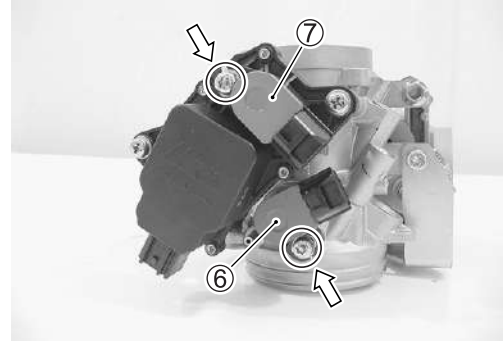

**CAUTION**

Never remove the STVA ⑧ from the throttle body.

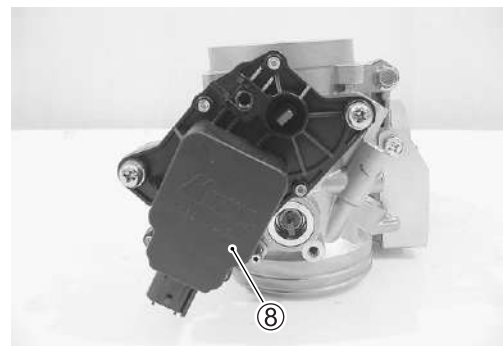

**CAUTION**

This screw ⑨ is factory-adjusted at the time of delivery and therefore avoid removing or turning it unless otherwise necessary.

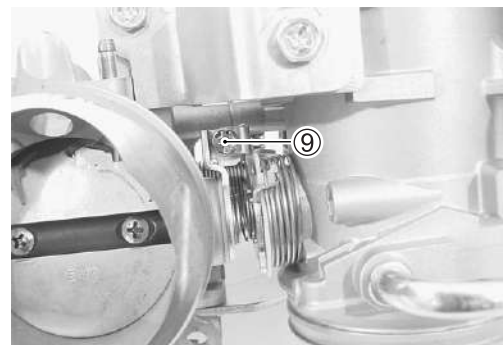

**CAUTION**

Never remove the secondary throttle valve ⑩ and throttle valve ⑪.

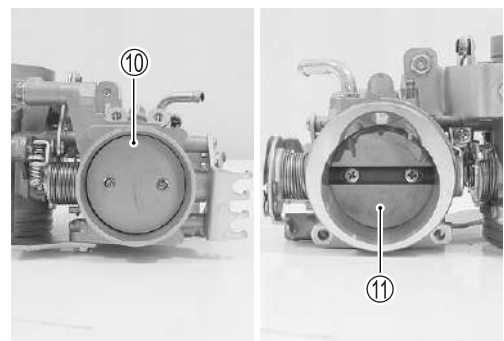

## THROTTLE BODY CLEANING

### **⚠ WARNING**

Some carburetor cleaning chemicals, especially dip-type soaking solutions, are very corrosive and must be handled carefully. Always follow the chemical manufacturer's instructions on proper use, handling and storage.

- Clean passageways (except for main bore) with a spray-type carburetor cleaner and blow dry with compressed air.

### **CAUTION**

- \* Never clean the main bore of throttle body to prevent come off molybdenum from the throttle valve.
- \* Do not use wire to clean passageways. Wire can damage passageways. If the components cannot be cleaned with a spray cleaner it may be necessary to use a dip-type cleaning solution and allow them to soak. Always follow the chemical manufacturer's instructions for proper use and cleaning of the throttle body components. Do not apply carburetor cleaning chemicals to the rubber and plastic materials.

## INSPECTION

- Check following items for any damage or clogging.
  - \* O-ring
  - \* Throttle valve
  - \* Secondary throttle valve
  - \* Vacuum hose
  - \* Delivery hose
  - \* Injector dust seal

## ISC VALVE INSPECTION

The ISC valve can be checked without removing it from the throttle body.

**\*Refer to the ISC VALVE INSPECTION for details. (👉 5-70)**

If the resistance is not within the standard range, replace the ISC valve motor assembly with a new one.

## ISC VALVE REMOVAL

Disconnect the hoses and remove the ISC valve ①.

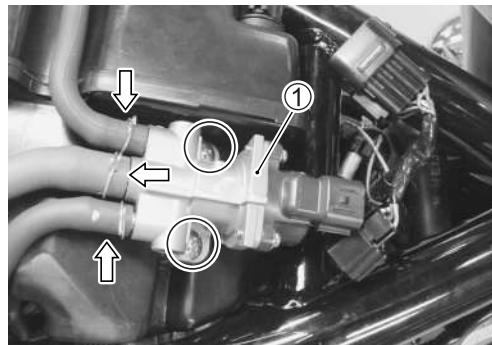

## INSPECTION

Check the ISC valve for wear or damage, replace it with a new one if necessary.



## ISC VALVE INSTALLATION

Install the ISC valve in the reverse order of removal.

## THROTTLE BODY REASSEMBLY

Reassemble the throttle body in the reverse order of disassembly. Pay attention to the following points:

- With the STV fully closed, install the STP sensor ① and tighten the STP sensor mounting screw to the specified torque.

### NOTE:

- \* Apply thin coat of the engine oil to the O-ring.
- \* Align the secondary throttle shaft end ① with the groove ② of STP sensor.
- \* Apply SUZUKI SUPER GREASE "A" to the secondary throttle shaft end ① if necessary.

 99000-25010: SUZUKI SUPER GREASE "A"  
or equivalent

 09930-11950: Torx wrench

 STP sensor mounting screw: 3.5 N·m (0.35 kgf·m, 2.5 lb-ft)

### NOTE:

- \* Make sure the STP valve open or close smoothly.
- \* If the STP sensor adjustment is necessary, refer to page 6-22 for STP sensor setting procedure.

- With the throttle valve fully closed, install the TP sensor ② and tighten the TP sensor mounting screw to the specified torque.

### NOTE:

- \* Apply thin coat of the engine oil to the O-ring.
- \* Align the throttle shaft end ③ with the groove ④ of TP sensor.
- \* Apply SUZUKI SUPER GREASE "A" to the throttle shaft end ③ if necessary.

 99000-25010: SUZUKI SUPER GREASE "A"  
or equivalent

 09930-11950: Torx wrench

 TP sensor mounting screw: 3.5 N·m (0.35 kgf·m, 2.5 lb-ft)

### NOTE:

- \* Make sure the throttle valve open or close smoothly.
- \* TP sensor setting procedure. (☞ 5-20)

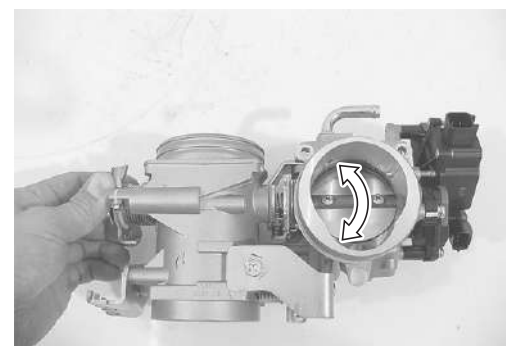
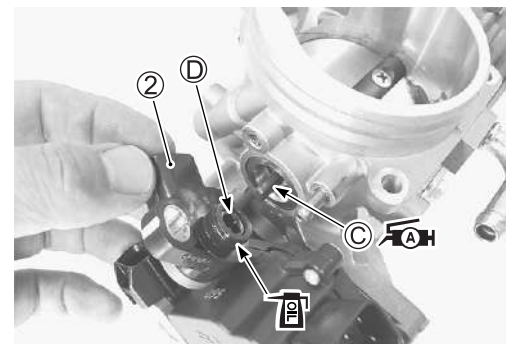
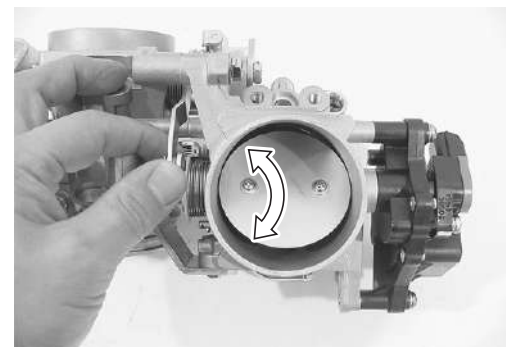
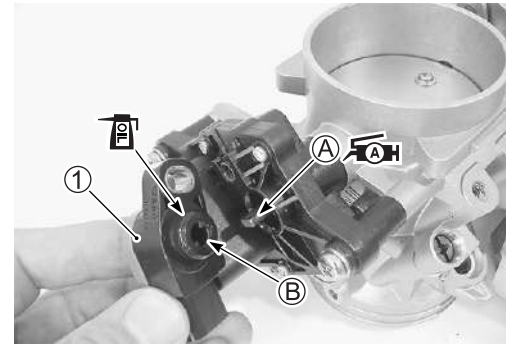

- Apply thin coat of the engine oil to the new cushion seal ③, and the O-ring ④.

**CAUTION**

**Replace the cushion seal and O-ring with the new ones.**

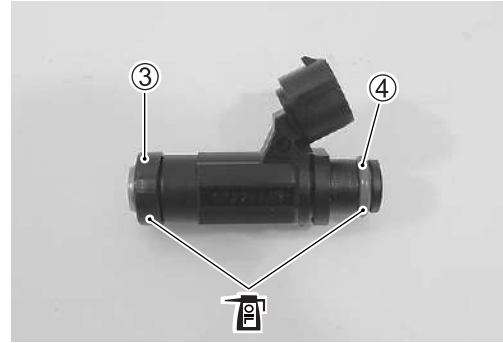

- Install the fuel injector ⑤ by pushing it straight to the delivery pipe ⑥.

**NOTE:**

*Align the coupler ⑤ of injector with boss ⑥ of the delivery pipe.*

**CAUTION**

**Never turn the injector while pushing it.**

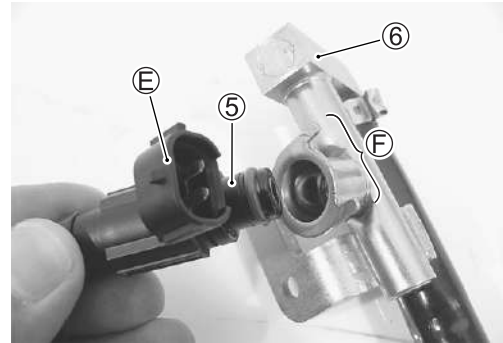

- Install the fuel delivery pipes and hose assembly ⑦ to the throttle body assembly.

**CAUTION**

**Never turn the fuel injectors while installing them.**

- Tighten the fuel delivery pipe mounting screws to the specified torque.

**🔧 Fuel delivery pipe mounting screw:**

**5 N·m (0.5 kgf-m, 3.5 lb-ft)**

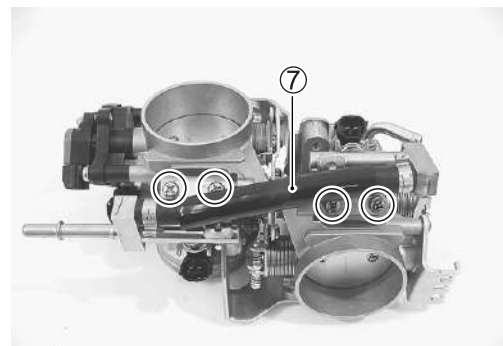



## AIR CLEANER CHAMBER AND THROTTLE BODY INSTALLATION

Installation is in the reverse order of removal. Pay attention to the following points:

- Connect the fuel injector couplers to the fuel injectors. Make sure that each coupler is installed in the correct position. The color on each lead wire refers to the appropriate fuel injector.  
Front injector lead wire ①: Y/R and Gr/B  
Rear injector lead wire ②: Y/R and Gr/W

**NOTE:**

Fit the clamp ① to the lead wire.

- Connect the TP sensor lead wire coupler ③ and STP sensor lead wire coupler ④.

**CAUTION**

**TP sensor lead wire coupler and STP sensor lead wire coupler resemble each other very closely in external appearance. Make sure to check the color of coupler before installing.**

TP sensor lead wire coupler ③: Gray

- Connect the throttle pulling cable ⑤ and throttle returning cable ⑥ to the throttle cable drum.

- Loosen each throttle cable lock nut.
- Turn in each throttle cable adjuster fully and locate each outer cable so that the clearance is 0 mm (0 in).
- Tighten each lock nut.
- Adjust the throttle cable play.  
Refer to page 2-19 for details.
- Install the air cleaner chamber and tighten the throttle body clamp screws as shown in the illustration. (11-41)

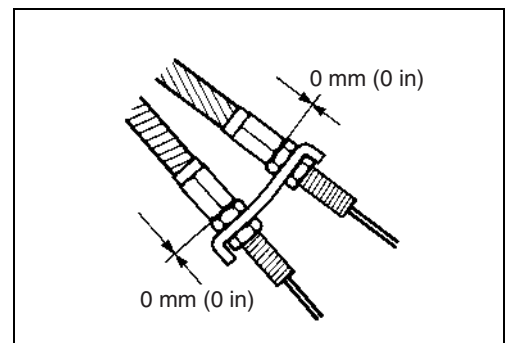
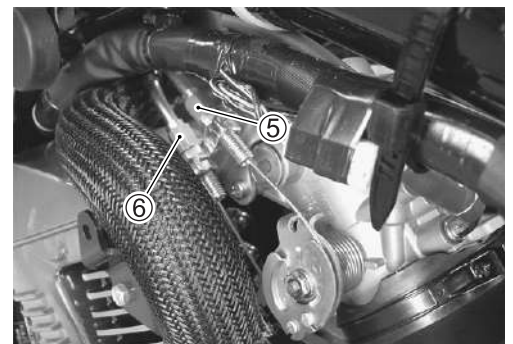
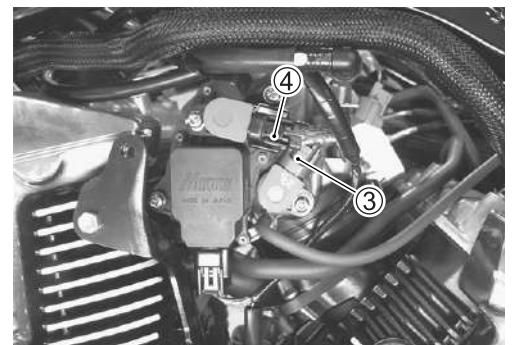
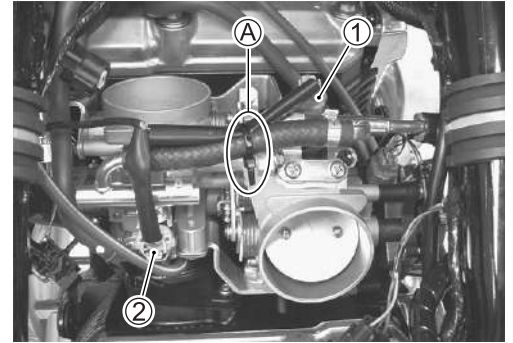

## STP SENSOR ADJUSTMENT

If the STP sensor adjustment is necessary, measure the sensor out put voltage and adjust the STP sensor position as follows:

- Remove the air cleaner chamber. (☞ 6-13)
- Disconnect the STVA coupler. (☞ 6-14)
- Insert the needle pointed probes to the STP sensor lead wire coupler.
- Turn the ignition switch ON.
- Close the secondary throttle valve by finger, and measure the STP sensor out put voltage.

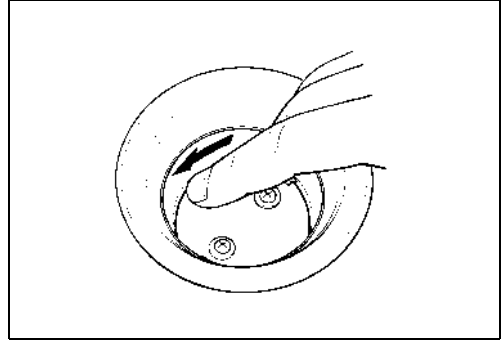

**DATA** STP sensor out put voltage  
 ST valve is fully closed: Approx. 0.6 V  
 (+ Y/W – (–) B/Br)

**TOOL** 09900-25008: Multi-circuit tester set  
 09900-25009: Needle pointed probe set

**TESTER** Tester knob indication: Voltage (V)

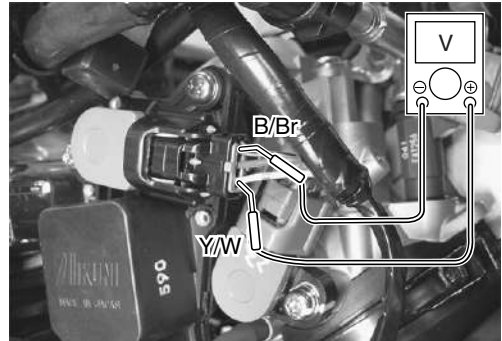

- If the STP sensor voltage is out of specification, loosen the STP sensor mounting screw and adjust the STP sensor voltage to specification.
- Tighten the STP sensor mounting screw.

**TOOL** 09930-11950: Torx wrench

**WRENCH** STP sensor mounting screw:  
 3.5 N·m (0.35 kgf-m, 2.5 lb-ft)

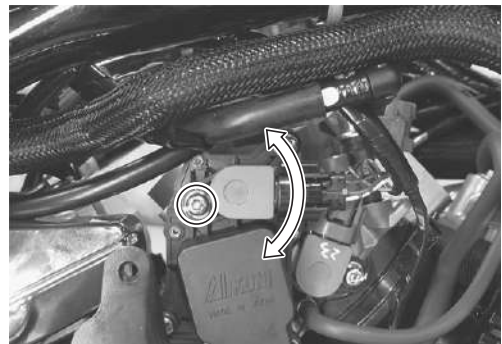

## FUEL INJECTOR REMOVAL

- Remove the fuel tank. (☞ 6-3)
- Remove the air cleaner chamber. (☞ 6-13)
- With battery negative cable disconnected, disconnect the injector couplers.
- Remove the fuel delivery pipes. (☞ 6-15)
- Remove the fuel injectors. (☞ 6-16)

## FUEL INJECTOR INSPECTION

Check fuel injector filter for evidence of dirt and contamination. If present, clean and check for presence of dirt in the fuel lines and fuel tank.

The fuel injector can be checked without removing it from the throttle body.

Refer to page 5-68 for details.



## FUEL INJECTOR INSTALLATION

- Apply thin coat of the engine oil to new injector cushion seals and O-rings. (☞ 6-20)
- Install the injector by pushing it straight to the throttle body. Never turn the injector while pushing it. (☞ 6-20)

## THROTTLE VALVE SYNCHRONIZATION

Check and adjust the throttle valve synchronization among two cylinders.

### Step 1

- Remove the fuel tank. (☞ 6-3)
- Remove the ISC valve. (☞ 6-18)
- Connect the ISC valve coupler ① and hoses ②.
- Connect the special tool (Mode select switch) to the dealer mode coupler. (☞ 5-18)
- Disconnect the vacuum hoses ③ from each throttle body.
- Connect the vacuum tester hoses ④ to each vacuum nipple on the throttle body.

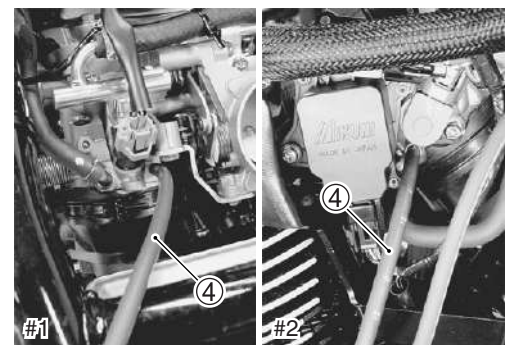
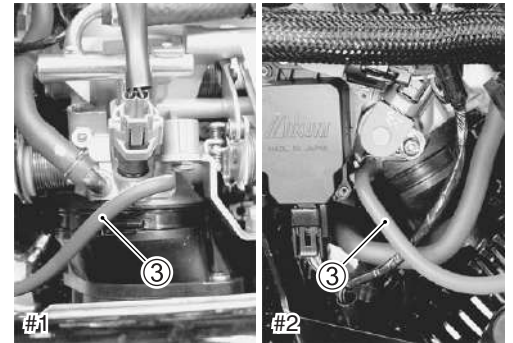
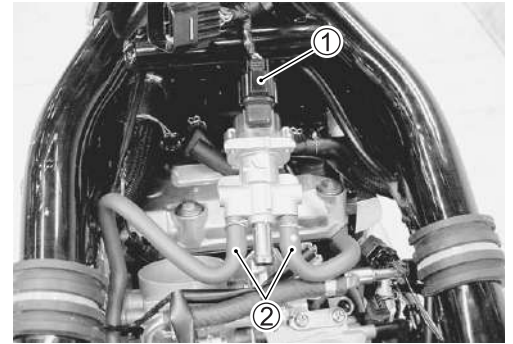

**Step 2**

- Warm up the engine as follows:  
Summer: approx. 5 min at idle r/min  
Winter: approx. 8 min at idle r/min
- Water temperature should be more than 80 °C (176 °F) and then wait 30 second.
- Then ISC valve automatically is set at throttle body synchronization position.
- Check for difference of vacuum between #1 and #2.
- Adjust the throttle valve synchronization and idling speed at 900 r/min by turning the air screw it necessary.

**CAUTION**

**Avoid dirt drawn into the throttle body while running the engine without air cleaner chamber. Dirt drawn into the engine will damage the internal engine parts.**

**NOTE:**

*Always set the engine rpm at 900 r/min.*

- If the adjustment is not yet correct, remove each air screw and clean them with a spray-type carburetor cleaner and blow dry with a compressed air.
- Also, clean the air screw passageways.

**NOTE:**

- \* *Slowly turn the air screw in clockwise and count the number of turns until the screw is lightly seated.*
- \* *Make a note of how many turns were made so the screw can be reset correctly after cleaning.*

**Step 3**

Repeat the procedures of Step 2.

## THROTTLE POSITION SENSOR (TPS) SETTING

After all adjustments are completed, check or adjust the TPS setting condition.

(Refer to page 5-20 for TPS setting procedure.)

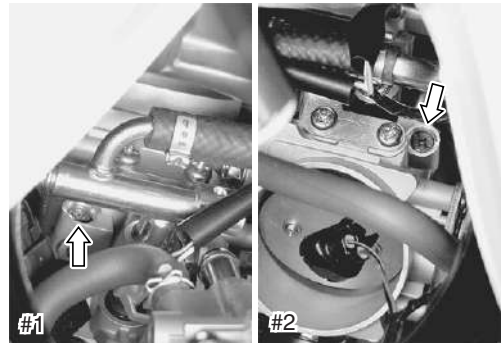

# EXHAUST SYSTEM

## CONTENTS

<b>EXCVA (EXHAUST CONTROL VALVE ACTUATOR) AND EXCV (EXHAUST CONTROL VALVE).....</b>	<b>7- 2</b>
<b>EXCVA AND EXCV REMOVAL .....</b>	<b>7- 2</b>
<b>EXCVA INSPECTION.....</b>	<b>7- 3</b>
<b>EXCV INSPECTION .....</b>	<b>7- 3</b>
<b>CABLE INSPECTION.....</b>	<b>7- 3</b>
<b>EXCVA AND EXCV INSTALLATION.....</b>	<b>7- 3</b>
<b>EXCVA ADJUSTMENT .....</b>	<b>7- 5</b>
<b>EXHAUST PIPE AND MUFFLER .....</b>	<b>7- 8</b>
<b>REMOVAL .....</b>	<b>7- 8</b>
<b>INSTALLATION.....</b>	<b>7-10</b>



## EXCVA (EXHAUST CONTROL VALVE ACTUATOR) AND EXCV (EXHAUST CONTROL VALVE)

### EXCVA AND EXCV REMOVAL

- Turn the ignition switch OFF.
- Remove the left frame side cover. (☞ 9-5)
- Connect the special tool (Mode select switch) to the dealer mode coupler. (☞ 5-18)
- After turning the special tool's switch ON, turn the ignition switch ON.

**TOOL** 09930-82720: Mode select switch

- Remove the rubber cover ①.
- Check the cable slots (A) of the EXCVA pulley face backward (adjustment position) as shown.
- Turn the ignition switch OFF.

#### CAUTION

**Before removing the EXCVA, be sure to set the EXCVA pulley to the adjustment position.**

- Remove the exhaust pipe and muffler. (☞ 7-8)
- Remove the EXCVA cover ②.
- Hold the EXCVA pulley with an adjustable wrench, and loosen the pulley mounting bolt.

#### CAUTION

- \* When loosening or tightening the pulley bolt, be sure to fix the pulley with an adjustable wrench, or EXCVA may get damaged.
- \* Do not use the adjustable wrench to turn EXCVA pulley so as not to cause damage to the internal gear of EXCVA.

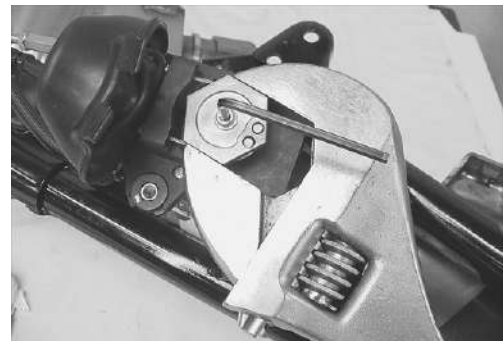
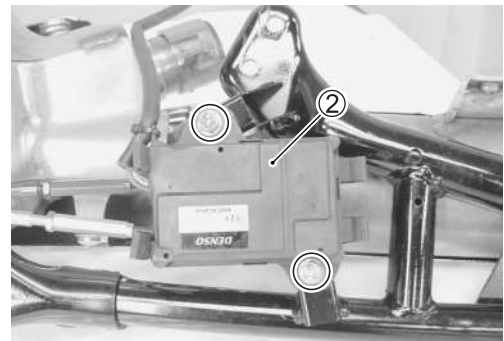
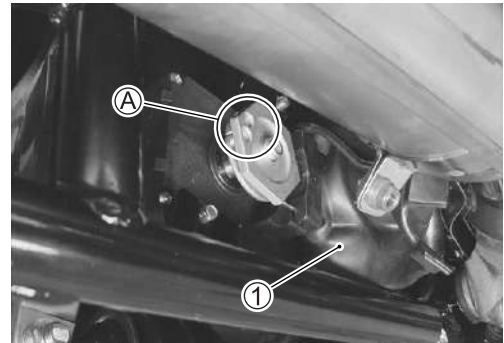



- Disconnect the No. 2 cable ③ and then No. 1 cable ④ from the pulley.
- Remove the EXCVA ⑤.

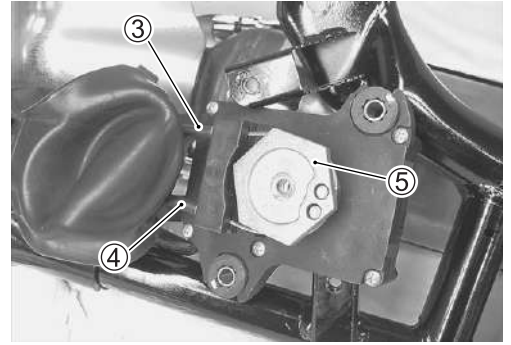

- Remove the EXCV cover ⑥ from the EXCV pulley.
- Disconnect the No. 1 ⑦ and No. 2 ⑧ cables.

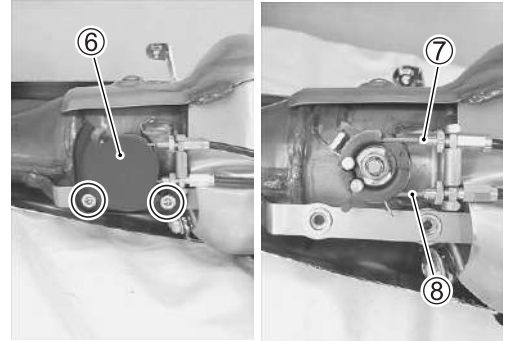

## EXCVA INSPECTION

👉 5-83

## EXCV INSPECTION

- Turn the EXCV by hand and check that it moves smoothly.
- If it does not move smoothly, replace the EXCV together with the muffler body.
- Decarbonize the EXCV if necessary.

### CAUTION

- \* Do not attempt to disassemble the EXCV.
- \* The EXCV is available only as the muffler body assembly.

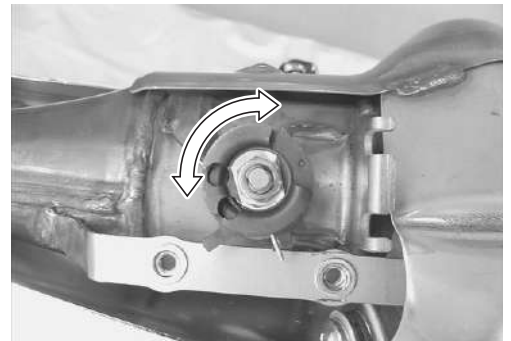

## CABLE INSPECTION

- Inspect the cables for wear or bend if it is damaged, replace it with a new one.

### NOTE:

The EXCV cables are identified by the plated chrome color and shape.

No. 1 cable ①: 11276-48G0

No. 2 cable ②: 11277-48G0

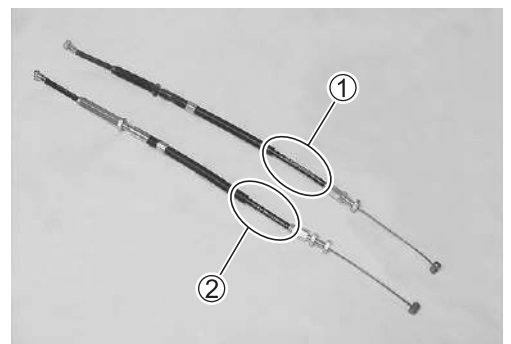

## EXCVA AND EXCV INSTALLATION

Install the EXCVA and EXCV in the reverse order of removal. Pay attention to the following points:

- Connect the EXCV cables temporarily to the EXCV pulley.
- Adjust the clearance **(A)** between the adjuster end and EXCV pulley to provide 4 mm (0.16 in) and more.
- Make the No. 1 cable straight and turn the No. 1 cable adjuster **(1)** in or out until the inner cable length **(B)** becomes 42 – 43 mm (1.65 – 1.69 in).
- After adjusting the inner cable length **(B)**, tighten the lock nut **(2)**.

No. 1 cable: 11276-48G0

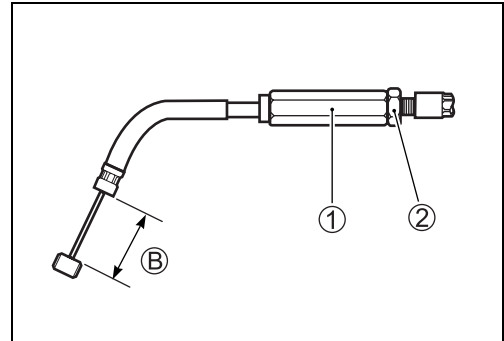
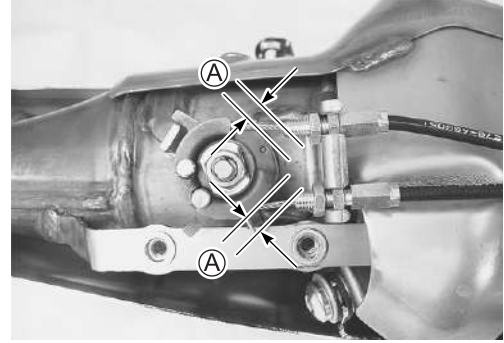

- Make the No. 2 cable straight and turn in the cable adjuster **(3)** fully.

No. 2 cable: 11277-48G0

- Loosen the lock nuts **(4)** and turn the No. 2 cable adjuster **(5)** in or out until the inner cable length **(C)** becomes 58 – 59 mm (2.28 – 2.32 in).
- After adjusting the inner cable length **(C)**, tighten the lock nuts **(4)**.

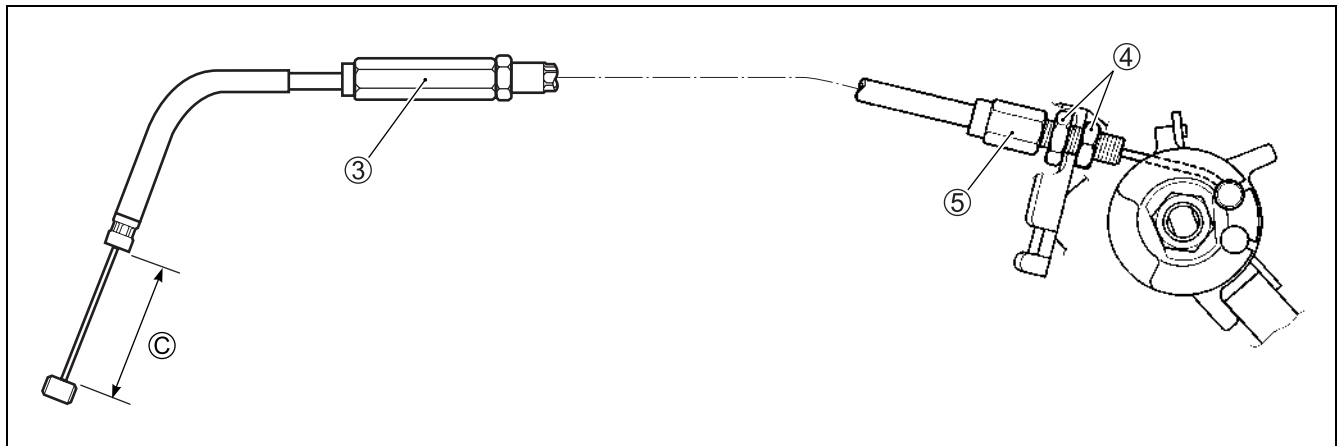

- Connect the No. 1 cable **(6)** and No. 2 cable **(7)** to the EXCVA pulley.

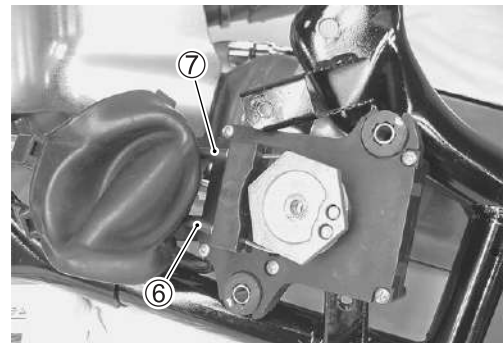

- Check the EXCVA to adjustment position. (☞ 7-2)

**CAUTION**

**Do not use the adjustable wrench to turn EXCVA pulley so as not to cause damage to the internal gear of EXCVA.**

- Install the pulley ⑧ to the shaft ⑨.

**NOTE:**

*Make sure that the shaft's line ① and cable slots ② facing upward as shown.*

- Hold the EXCVA pulley with an adjustable wrench, and then tighten the pulley mounting bolt to the specified torque.

**EXCVA pulley mounting bolt: 5 N·m (0.5 kgf·m, 3.5 lb-ft)**

**CAUTION**

**When loosening or tightening the pulley bolt, be sure to fix the pulley with an adjustable wrench, or EXCVA may get damaged.**

- After connecting the No. 2 cable ⑩, loosen the lock nut ⑪ and turn the adjuster ⑫ in or out until 8.5 – 9.5 mm (0.33 – 0.37 in) of the thread length ⑬ on the cable adjuster can be provided and tighten the lock nut ⑪.

**CAUTION**

**The cable slots of the EXCVA pulley must be located backward (adjustment position). (☞ 7-2)**

**NOTE:**

*Install the rubber cover ⑬ correctly after inspecting it.*

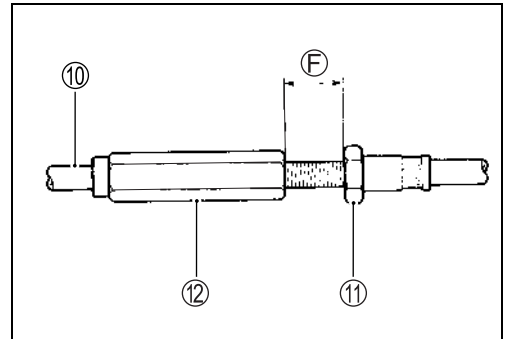
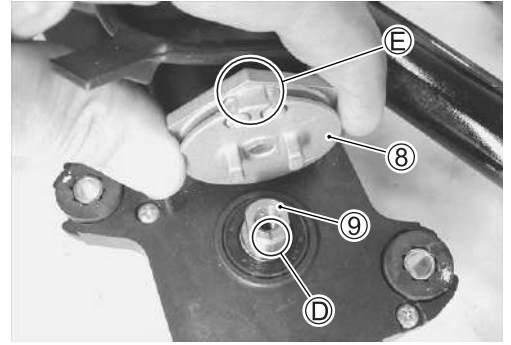

## EXCVA ADJUSTMENT

### 1st step:

- Set the EXCVA to adjustment position. (☞ 7-2)

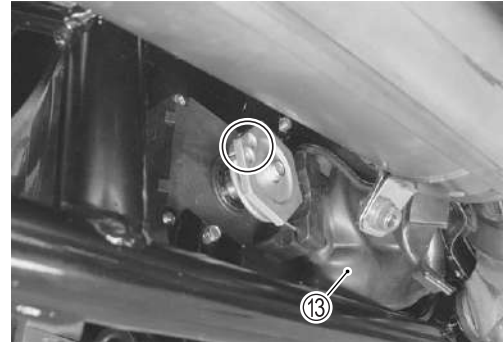

- Make sure that the No. 2 cable and No. 1 cable are fixed into the clamp.

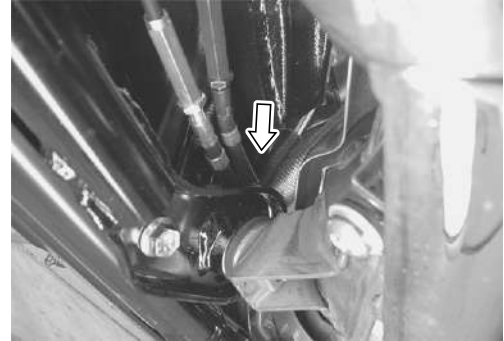

### 2nd step:

- Turn the mode select switch OFF.
- Turn the ignition switch ON to check the EXCVA operation.
- Turn the mode select switch ON.
- If C46 is not indicated on the LCD (DISPLAY), the adjustment is correctly completed. In this case, it is unnecessary to proceed to 3rd step.
- If C46 is indicated, repeat the adjustment procedure from 3rd and 4th step.

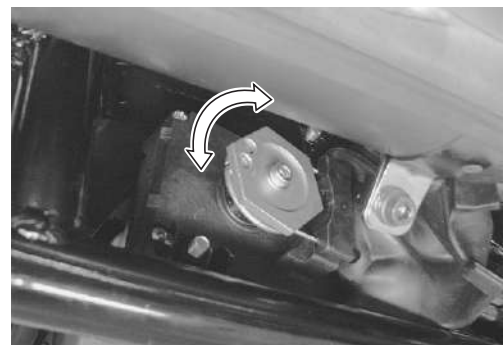
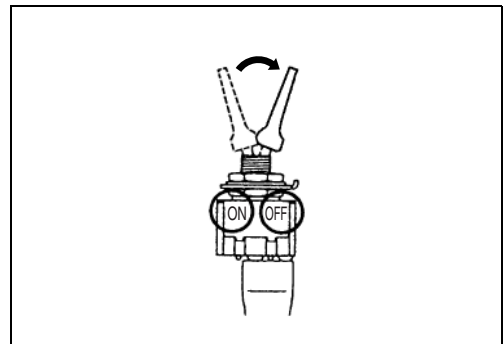

### 3rd step:

- This procedure is only required when C46 is indicated.
- Turn the ignition switch OFF.
- Remove the lower frame cover. (☞ 7-8)
- Insert the two copper wires into the back side of the position sensor lead wire coupler ①.
- Disconnect the EXCVA motor lead wire coupler ②.

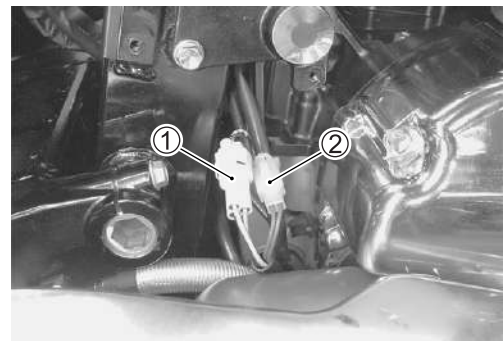

- To set the EXCV to fully close position, apply 12 volts to ① and ② terminals.  
Positive wire — ① (Pink wire) terminal  
Negative wire — ② (Gray wire) terminal

**CAUTION**

To prevent the motor damage, stop applying 12 V as soon as the EXCV reaches fully close position.

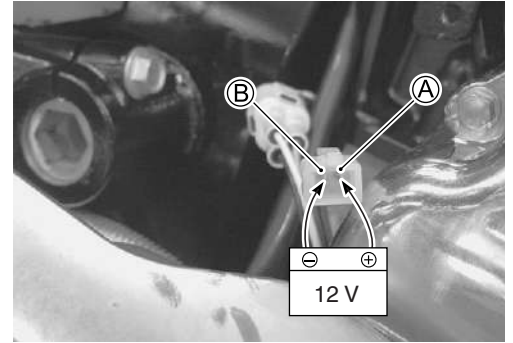

- Turn the ignition switch ON.
- Measure the position sensor output voltage at fully close position.

**DATA** Position sensor output voltage

EXCV is fully close:  $0.5 \leq \text{output voltage} \leq 1.5 \text{ V}$   
(+ Yellow - ② B/Br)

**TOOL** 09900-25008: Multi circuit tester set  
09900-25009: Needle pointed probe set

**Tester knob indication: Voltage (V)**

If the measured voltage is less than specification, adjust the No.1 cable adjuster as follows:

- Set the EXCVA to adjustment position. (↔ 7-2)

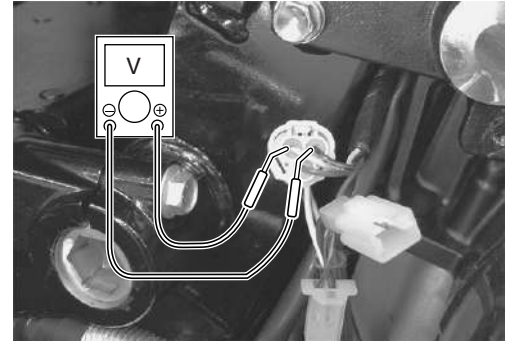
**CAUTION**

Adjusting the No. 1 cable with the EXCV fully closed can damage the EXCVA. Be sure to adjust the No.1 cable with the EXCV set in adjustment position.



- Turn out the No. 1 cable adjuster ③.
- Repeat the above procedure until the output voltage becomes specified value.

**DATA** Position sensor output voltage

EXCV is fully close:  $0.5 \leq \text{output voltage} \leq 1.5 \text{ V}$

- To next step.

**NOTE:**

If C46 code is indicated after adjusting the voltage, increase the voltage to 0.9 V.

**4th step:**

To set the EXCV to fully open position, apply 12 volts to ① and ② terminals.

Positive wire — ② (Gray wire) terminal  
Negative wire — ① (Pink wire) terminal

**CAUTION**

To prevent the motor damage, stop applying 12 V as soon as the EXCV reaches fully open position.

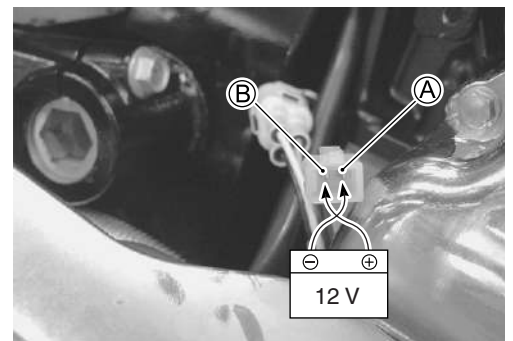



Measure the position sensor output voltage at fully open position.

**DATA** Position sensor output voltage

EXCV is fully open:  $3.5 \leq \text{output voltage} \leq 4.5 \text{ V}$   
 (+ Yellow - B/Br)

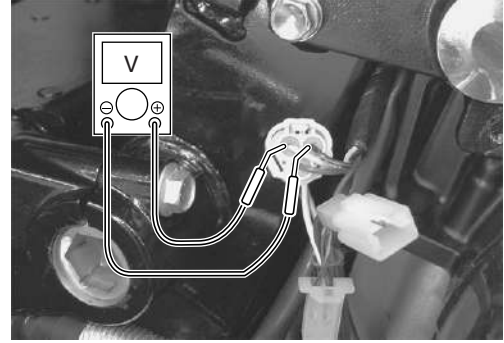

If the measured voltage is more than specification, adjust the No.2 cable adjuster as follows:

- Set the EXCVA to adjustment position. (↗7-2)

**CAUTION**

Adjusting the No. 2 cable with the EXCV fully opened can damage the EXCVA. Be sure to adjust the No. 2 cable with the EXCV set in adjustment position.

- Turn out the No. 2 cable adjuster ①.
- Repeat the above procedure until the output voltage comes within the specified value.



**DATA** Position sensor output voltage

EXCV is fully open:  $3.5 \leq \text{output voltage} \leq 4.5 \text{ V}$

- After adjusting the EXCVA cables, perform 2nd step to confirm C46 is not indicated.

## EXHAUST PIPE AND MUFFLER REMOVAL

- Remove the right frame cover. (↗9-5)
- Remove the lower frame cover ①.
- Disconnect the EXCVA lead wire couplers ②.

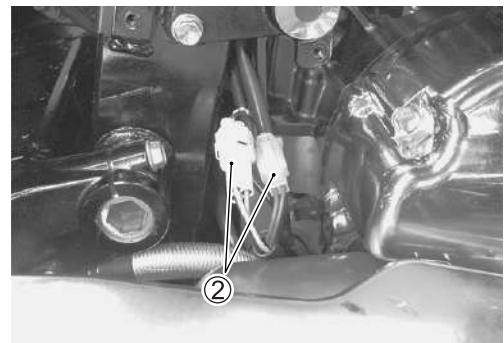
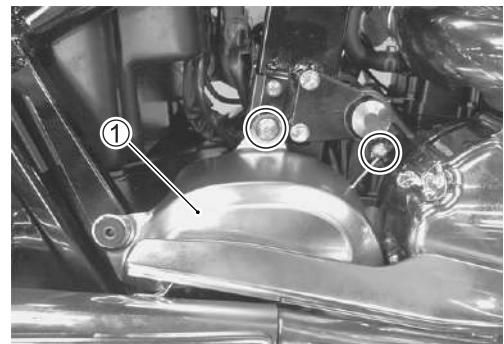



- Disconnect the front and rear HO2 sensor lead wire couplers. (For E-02, 19, 24)

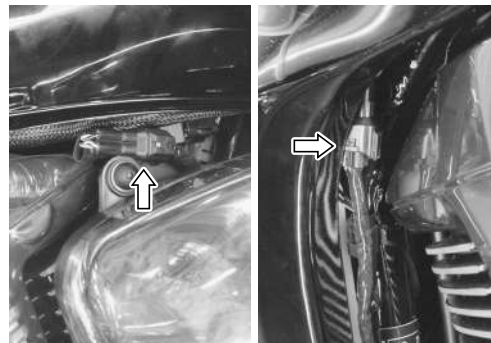

- Remove the muffler cover ③.

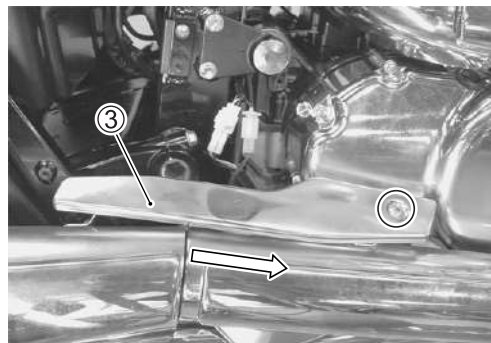

- Remove the No. 1 muffler ④.

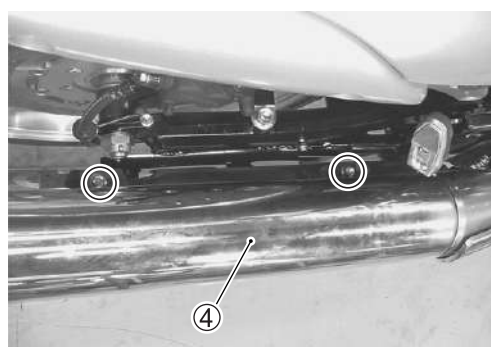
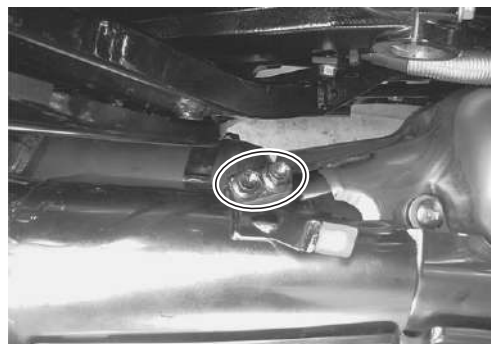

- Remove the right frame lower cover ⑤.

**NOTE:**

“☆” indicates hook location.



- Remove the exhaust pipes ⑥ and the No. 2 muffler ⑦.

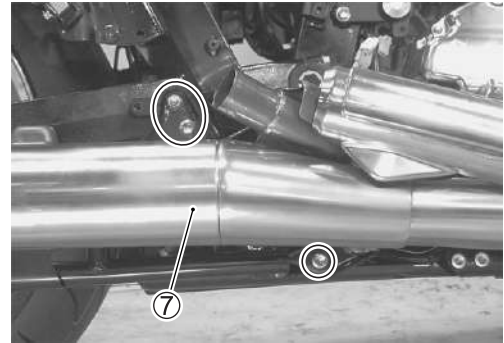
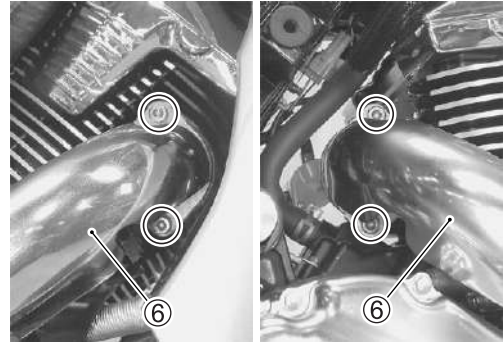

## INSTALLATION

Install the exhaust pipe and muffler in the reverse order of removal. Pay attention to the following points:

- Install the exhaust pipes ① with the No. 2 muffler ②.

### CAUTION

Replace the gaskets with new ones.

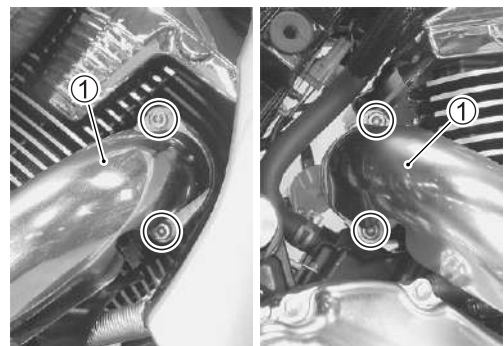

- Tighten the exhaust pipe bolts and No. 2 muffler bolts and nut to the specified torque.

-  Exhaust pipe bolt : 23 N·m (2.3 kgf-m, 16.5 lb-ft)  
 Muffler mounting bolt and nut: 23 N·m (2.3 kgf-m, 16.5 lb-ft)

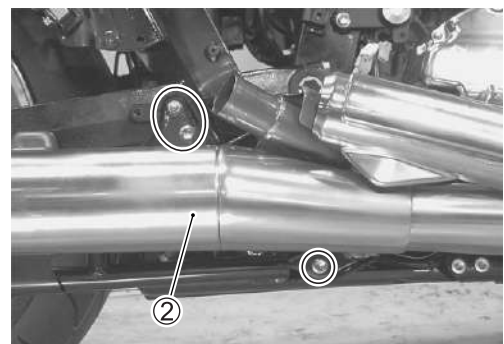

- Apply gas sealer to the exhaust pipe connectors.

EXHAUST GAS SEALER: PERMATEX 1372

### CAUTION

Replace the exhaust pipe connector with new ones.



- Install the No. 1 muffler ③.
- Tighten the No. 1 muffler bolts and muffler connecting bolts.

 **Muffler mounting bolt : 23 N·m (2.3 kgf-m, 16.5 lb-ft)**

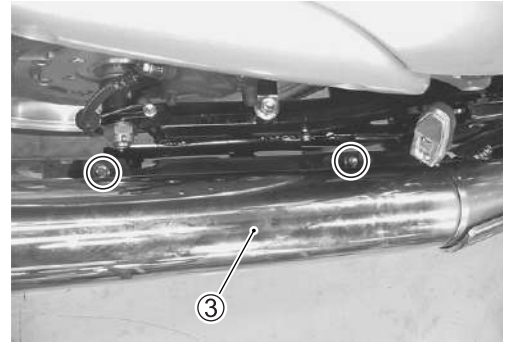

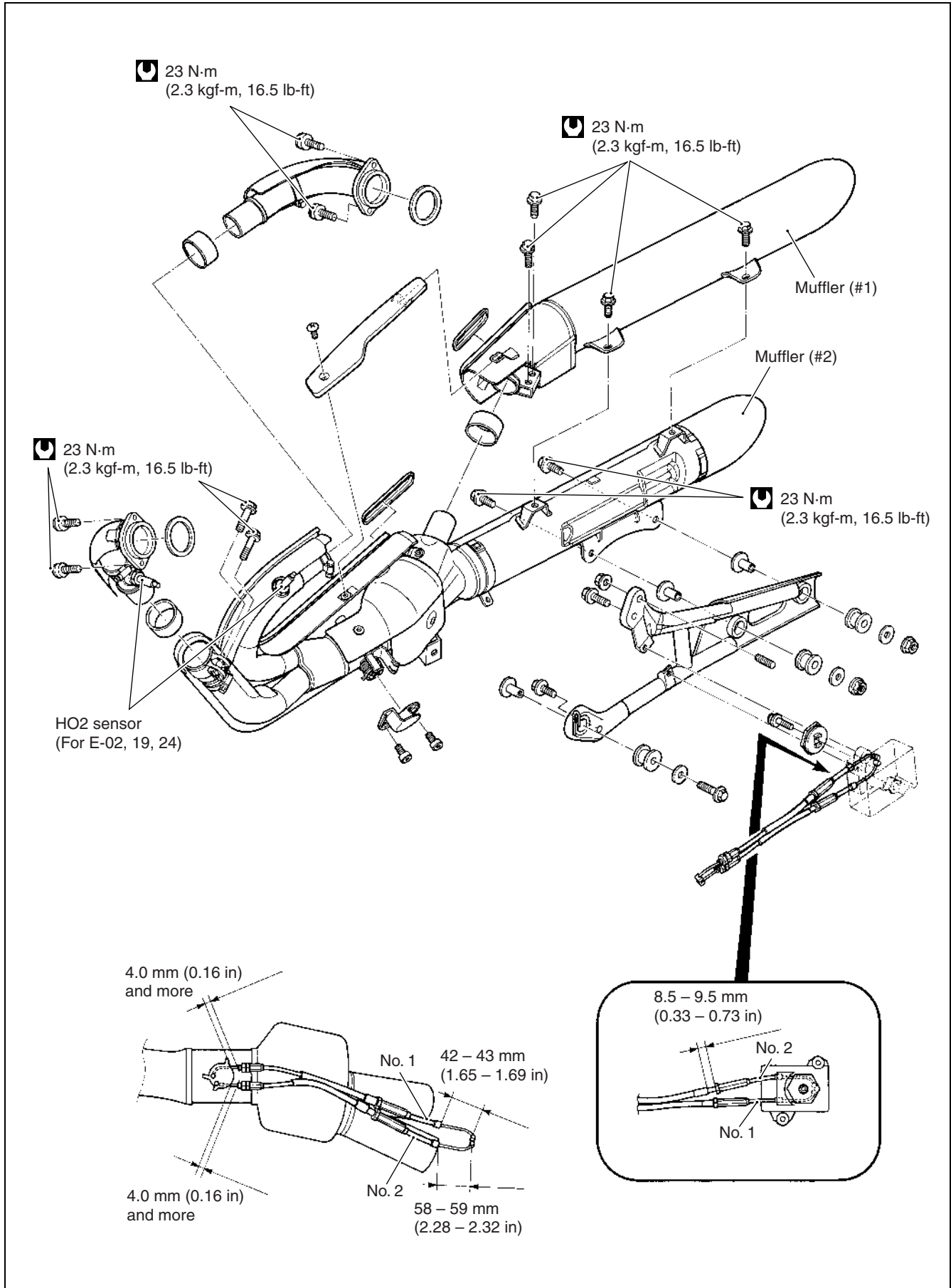

# COOLING AND LUBRICATION SYSTEM

## CONTENTS

<b>ENGINE COOLANT .....</b>	<b>8- 2</b>
<b>COOLING CIRCUIT .....</b>	<b>8- 3</b>
<b>COOLING CIRCUIT INSPECTION.....</b>	<b>8- 3</b>
<b>RADIATOR AND WATER HOSE.....</b>	<b>8- 4</b>
<b>RADIATOR REMOVAL AND DISASSEMBLY .....</b>	<b>8- 4</b>
<b>RADIATOR DISASSEMBLY .....</b>	<b>8- 5</b>
<b>RADIATOR CAP INSPECTION.....</b>	<b>8- 5</b>
<b>RADIATOR INSPECTION AND CLEANING.....</b>	<b>8- 6</b>
<b>RADIATOR REASSEMBLY .....</b>	<b>8- 6</b>
<b>RADIATOR INSTALLATION.....</b>	<b>8- 6</b>
<b>WATER HOSE INSPECTION.....</b>	<b>8- 7</b>
<b>COOLING FAN.....</b>	<b>8- 8</b>
<b>INSPECTION .....</b>	<b>8- 8</b>
<b>COOLING FAN RELAY INSPECTION.....</b>	<b>8- 8</b>
<b>ECT SENSOR .....</b>	<b>8- 9</b>
<b>REMOVAL .....</b>	<b>8- 9</b>
<b>INSPECTION .....</b>	<b>8- 9</b>
<b>INSTALLATION.....</b>	<b>8-10</b>
<b>THERMOSTAT.....</b>	<b>8-11</b>
<b>REMOVAL .....</b>	<b>8-11</b>
<b>INSPECTION .....</b>	<b>8-11</b>
<b>INSTALLATION.....</b>	<b>8-12</b>
<b>WATER PUMP .....</b>	<b>8-13</b>
<b>REMOVAL AND DISASSEMBLY .....</b>	<b>8-13</b>
<b>INSPECTION .....</b>	<b>8-15</b>
<b>REASSEMBLY AND INSTALLATION.....</b>	<b>8-16</b>
<b>ENGINE LUBRICATION SYSTEM CHART.....</b>	<b>8-19</b>

## ENGINE COOLANT

At the time of manufacture, the cooling system is filled with a 50:50 mixture of distilled water and ethylene glycol anti-freeze. This 50:50 mixture will provide the optimum corrosion protection and excellent heat protection, and will protect the cooling system from freezing at temperatures above  $-31\text{ }^{\circ}\text{C}$  ( $-24\text{ }^{\circ}\text{F}$ ).

If the motorcycle is to be exposed to temperatures below  $-31\text{ }^{\circ}\text{C}$  ( $-24\text{ }^{\circ}\text{F}$ ), this mixing ratio should be increased up to 55% or 60% according to the figure.

Anti-freeze density	Freezing point
50%	$-30\text{ }^{\circ}\text{C}$ ( $-24\text{ }^{\circ}\text{F}$ )
55%	$-40\text{ }^{\circ}\text{C}$ ( $-44\text{ }^{\circ}\text{F}$ )
60%	$-55\text{ }^{\circ}\text{C}$ ( $-67\text{ }^{\circ}\text{F}$ )

### CAUTION

- \* Use a high quality ethylene glycol base anti-freeze, mixed with distilled water. Do not mix an alcohol base anti-freeze and different brands of anti-freeze.
- \* Do not put in 60% and more anti-freeze or 50% and less. (Refer to below figure.)
- \* Do not use a radiator anti-leak additive.

50% Engine coolant including reserve tank capacity

Anti-freeze	1 350 ml (2.9/2.4 US/Imp.pt)
Water	1 350 ml (2.9/2.4 US/Imp.pt)

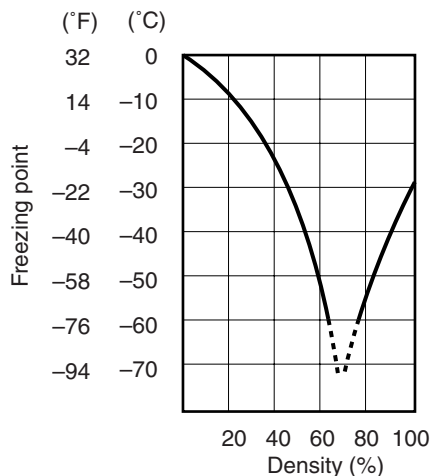

Fig. 1 Engine coolant density-freezing point curve

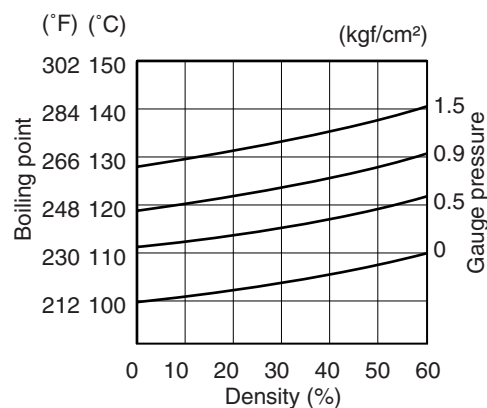

Fig. 2 Engine coolant density-boiling point curve

### WARNING

- \* You can be injured by scalding fluid or steam if you open the radiator cap when the engine is hot. After the engine cools, wrap a thick cloth around cap and carefully remove the cap by turning it a quarter turn to allow pressure to escape and then turn the cap all the way off.
- \* The engine must be cool before servicing the cooling system.
- \* Coolant is harmful;
  - If it comes in contact with skin or eyes, flush with water.
  - If swallowed accidentally, induce vomiting and call physician immediately.
  - Keep it away from children.



## COOLING CIRCUIT

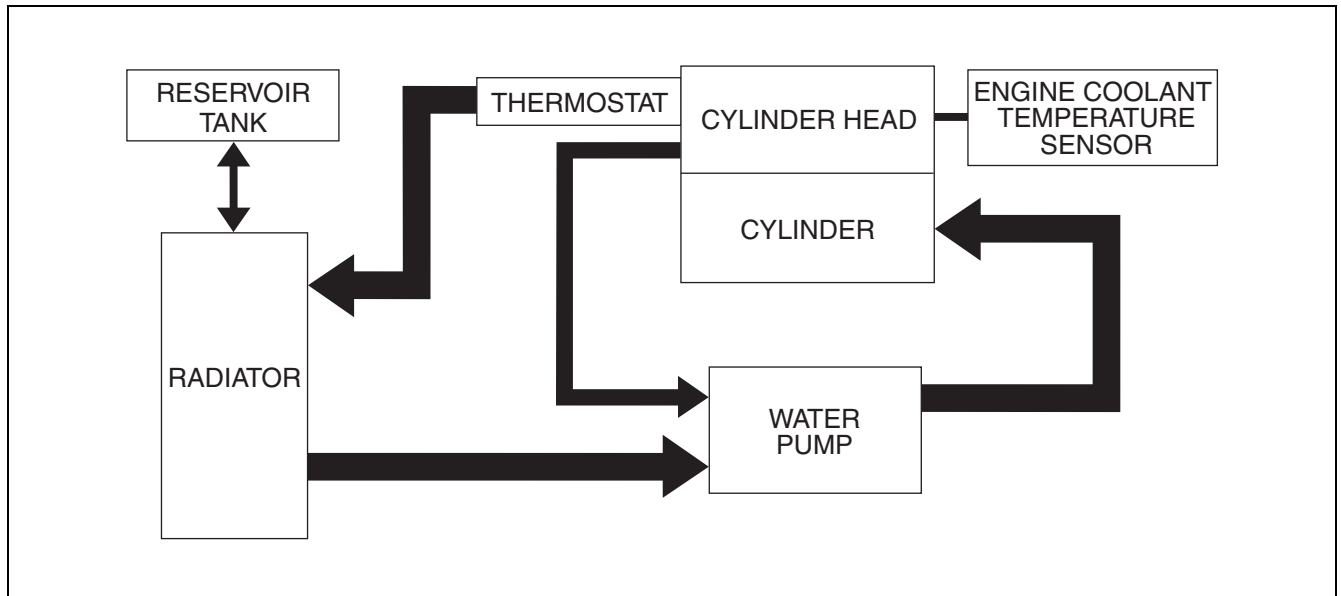

## COOLING CIRCUIT INSPECTION

Before removing the radiator and draining the engine coolant, inspect the cooling circuit for tightness.

- Remove the fuel tank. (☞ 6-3)
- Remove the left frame head cover. (☞ 9-6)
- Remove the radiator cap ① and connect the tester ② to the filler.

### ⚠ WARNING

**Do not remove the radiator cap when the engine is hot.**

- Give a pressure of about 110 kPa (1.1 kgf/cm<sup>2</sup>, 15.6 psi) and see if the system holds this pressure for 10 seconds.
- If the pressure should fall during this 10-second interval, it means that there is a leaking point in the system. In such a case, inspect the entire system and replace the leaking component or part.

### ⚠ WARNING

**When removing the radiator cap tester, put a rag on the filler to prevent spouting of engine coolant.**

### CAUTION

**Do not allow the pressure to exceed the radiator cap release pressure, or the radiator can be damaged.**

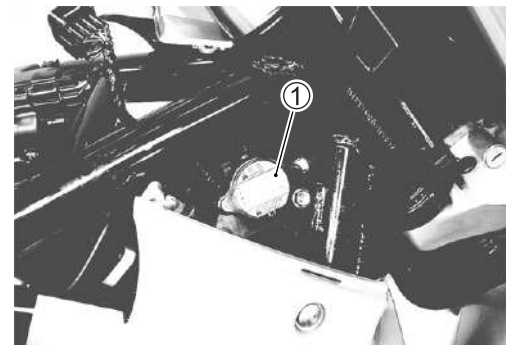

## RADIATOR AND WATER HOSE

### RADIATOR REMOVAL AND DISASSEMBLY

- Remove the fuel tank. (☞ 6-3)
- Remove the frame head covers and radiator covers. (☞ 9-6)
- Drain the engine coolant. (☞ 2-20)
- Disconnect the reservoir hose ① and cooling fan lead wire coupler ②.

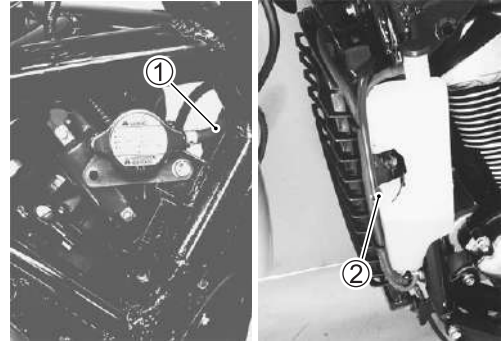

- Disconnect the oil cooler water outlet hose ③ and remove the radiator lower mounting bolt.

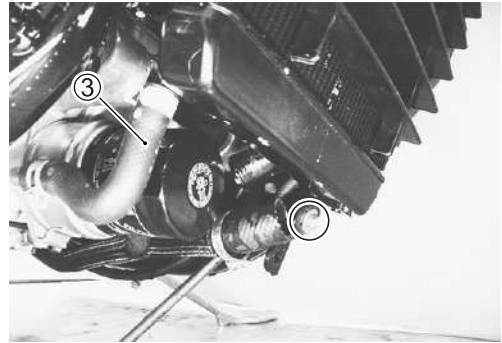

- Remove the radiator upper mounting bolts and disconnect the inlet hose ④.
- Remove the radiator.

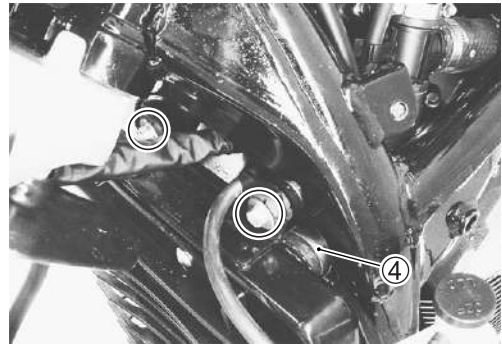

## RADIATOR DISASSEMBLY

- Remove the reservoir tank ①.
- Remove the cooling fan ② and shield ③.
- Remove the radiator guard ④.

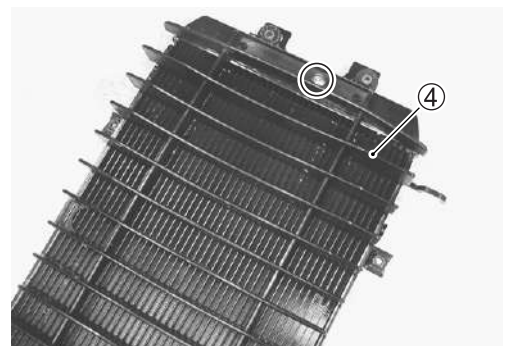
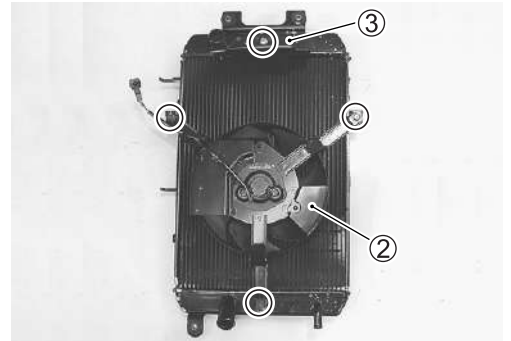
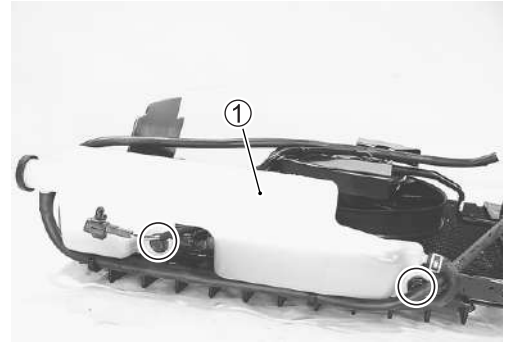

## RADIATOR CAP INSPECTION

- Fit the cap ① to the radiator cap tester ②.
- Build up pressure slowly by operating the tester. Make sure that the pressure build-up stops at 93 – 123 kPa (0.93 – 1.23 kgf/cm<sup>2</sup>, 13.2 – 17.5 psi) and that, with the tester held stand-still, the cap is capable of holding that pressure for at least 10 seconds.
- Replace the cap if it is found not to satisfy either of these two requirements.

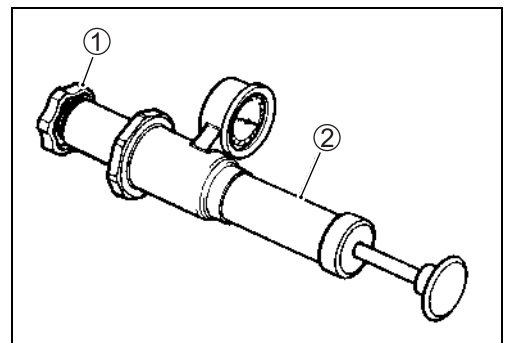

### **DATA** Radiator cap valve opening pressure

Standard: 93 – 123 kPa

(0.93 – 1.23 kgf/cm<sup>2</sup>, 13.2 – 17.5 psi)

## RADIATOR INSPECTION AND CLEANING

- Road dirt or trash stuck on the fins must be removed.
- Use of compressed air is recommended for this cleaning.



- Fins bent down or dented can be repaired by straightening them with the blade of a small screwdriver.



## RADIATOR REASSEMBLY

Reassemble the radiator in the reverse order of disassembly. Pay attention to the following points:

- Install the radiator guard ①.

### NOTE:

Fit the radiator onto the concave part **A** of the radiator guard.

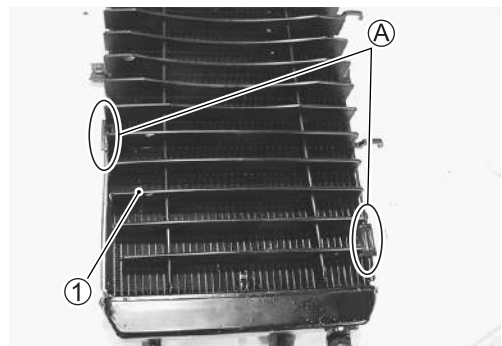

## RADIATOR INSTALLATION

- Install the radiator.
- Route the radiator hoses. (👉 11-42)
- Bleed air from the cooling circuit. (👉 2-21)

## WATER HOSE INSPECTION

- Remove the fuel tank. (☞ 6-3)
- Remove the frame head covers and radiator covers. (☞ 9-6)
- Remove the left and right air cleaner boxes. (☞ 6-13)
- Remove the secondary gear case cover. (☞ 3-6)
- Any water hose found in a cracked condition or flattened must be replaced.
- Any leakage from the connecting section should be corrected by proper tightening.

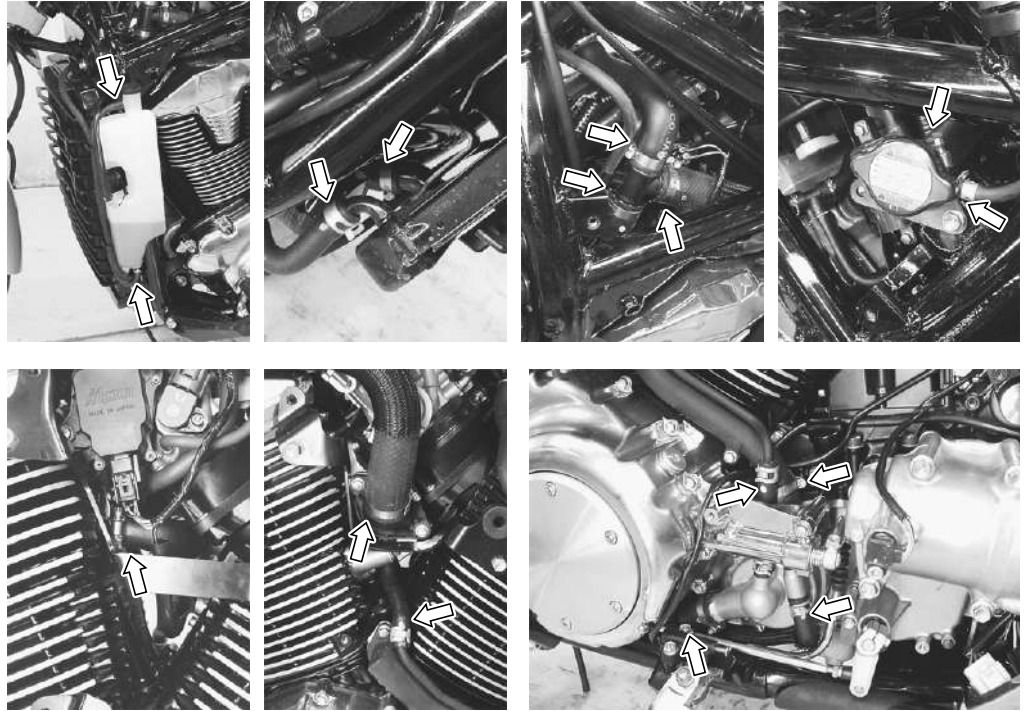

## COOLING FAN

### INSPECTION

- Remove the right frame head cover and right radiator cover. (☞ 9-6)
- Disconnect the cooling fan coupler ①.
- Test the cooling fan motor for load current with an ammeter connected as shown in the illustration.

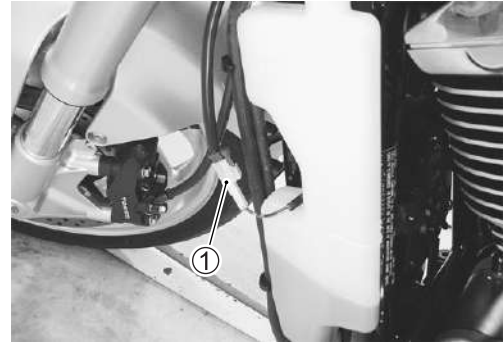

- The voltmeter is for making sure that the battery ② applies 12 volts to the cooling fan motor ③. With the cooling fan motor with electric motor fan running at full speed, the ammeter ④ should be indicating not 8.5 amperes and more.
- If the fan motor does not turn, replace the motor assembly with a new one. (☞ 8-5)

#### NOTE:

When making above test, it is not necessary to remove the cooling fan.

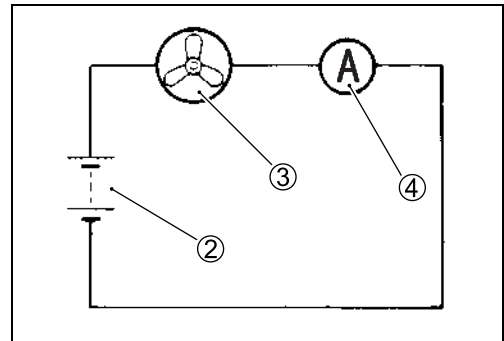

### COOLING FAN RELAY INSPECTION

Cooling fan relay is located in front of the battery.

- Remove the right frame side cover. (☞ 9-5)
- Remove the cooling fan relay ①.

First check the insulation between (A) and (B) terminals with tester. Then apply 12 volts to (C) and (D) terminals, (+) to (C) and (-) to (D), and check the continuity between (A) and (B). If there is no continuity, replace it with a new one.

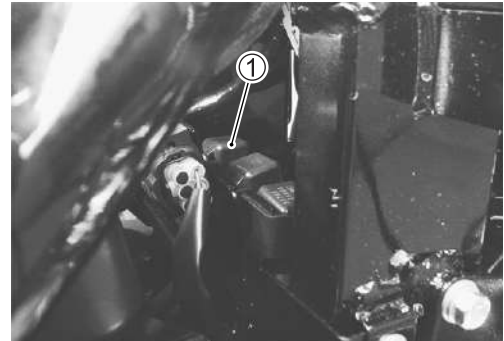

 **09900-25008: Multi-circuit tester set**

 **Tester knob indication: Continuity test (•••••)**

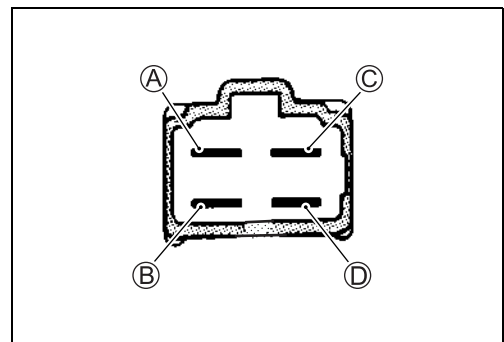



## ECT SENSOR

### REMOVAL

- Drain the engine coolant. (☞ 2-20)
- Remove the air cleaner chamber and throttle body. (☞ 6-13)
- Disconnect the ECT sensor coupler ①.
- Remove the rear intake pipe and thermostat assembly. (☞ 3-13)

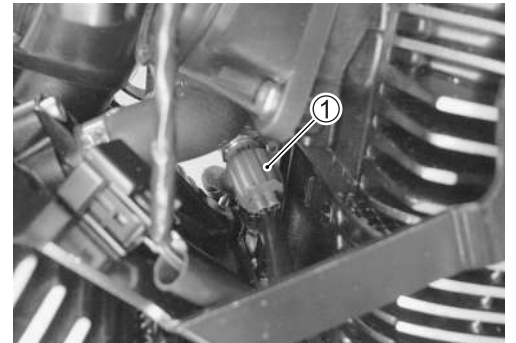

- Remove the ECT sensor ②.

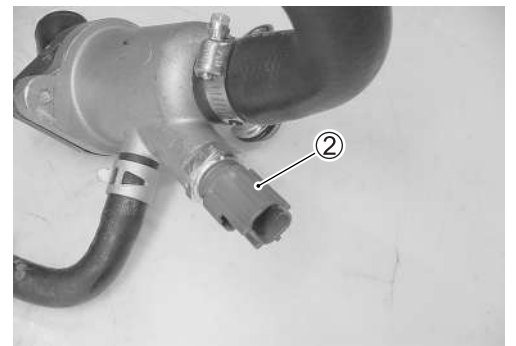

### INSPECTION

- Check the ECT sensor by testing it at the bench as shown in the figure. Connect the ECT sensor ① to a circuit tester and place it in the oil ② contained in a pan, which is placed on a stove.
- Heat the oil to raise its temperature slowly and read the column thermometer ③ and the ohmmeter.
- If the ECT sensor ohmic value does not change in the proportion indicated, replace it with a new one.

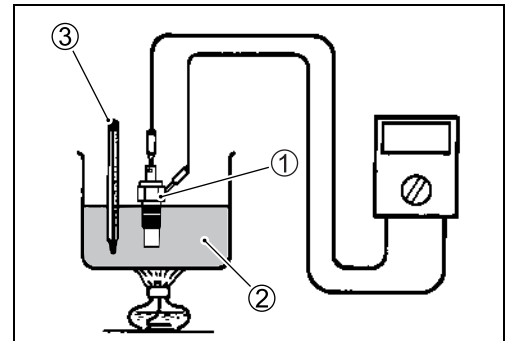

#### **DATA** Temperature sensor specification

Temperature	Standard resistance
20 °C (68 °F)	Approx. 2.45 kΩ
50 °C (122 °F)	Approx. 0.811 kΩ
80 °C (176 °F)	Approx. 0.318 kΩ
110 °C (230 °F)	Approx. 0.142 kΩ

#### **DATA** Cooling fan operating temperature:

Standard (OFF→ON): Approx. 105 °C (221 °F)

(ON→OFF): Approx. 100 °C (212 °F)

#### NOTE:

As coolant temperature rises, the cooling fan operates for 5 seconds when the temperature arrives each at 50 – 70 °C (122 – 158 °F), 70 – 90 °C (158 – 194 °F) and 90 – 110 °C (194 – 230 °F)/above 4 000 r/min.

If the resistance is noted to show infinity or too much different resistance value, replace the ECT sensor with a new one.

**CAUTION**

- \* Take special care when handling the ECT sensor. It may cause damage if it gets a sharp impact.
- \* Do not contact the ECT sensor and the column thermometer with a pan.

## INSTALLATION

- Install the new sealing washer ①.
- Tighten the ECT sensor ② to the specified torque.

 ECT sensor: 18 N·m (1.8 kgf-m, 13.0 lb-ft)

**CAUTION**

- \* Replace the removed sealing washer ① with a new one.
- \* Take special care when handling the ECT sensor. It may cause damage if it gets a sharp impact.

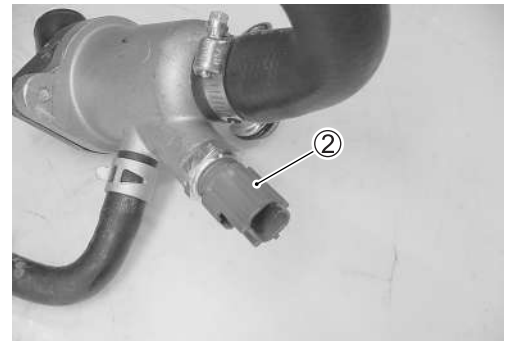

- Install the rear intake pipe and thermostat assembly. (👉 3-112)
- Install the air cleaner chamber and throttle body. (👉 6-21)
- Pour engine coolant. (👉 2-21)

## THERMOSTAT

### REMOVAL

- Remove the left air cleaner box. (☞ 6-13)
- Place a rag under the thermostat cover.
- Remove the thermostat cover ①.

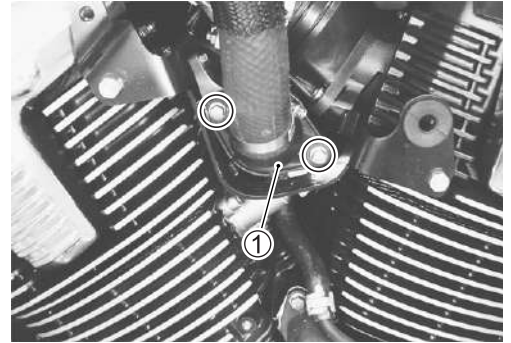

- Remove the thermostat ②.

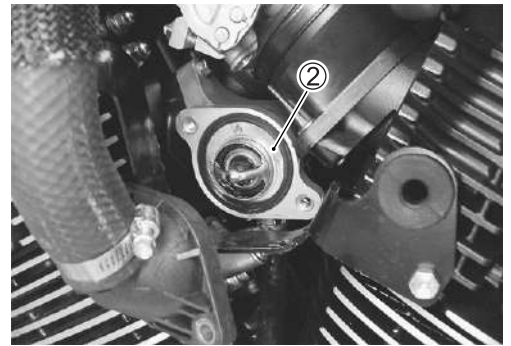

### INSPECTION

Inspect the thermostat pellet for signs of cracking.

Test the thermostat at the bench for control action, in the following manner.

- Pass a string ① between flange ② of thermostat, as shown.
- Immerse the thermostat in the water contained in a beaker, as shown in the illustration. Note that the immersed thermostat is in suspension. Heat the water ③ by placing the beaker on a stove ④ and observe the rising temperature on a thermometer ⑤.
- Read the thermometer just when opening the thermostat. This reading, which is the temperature level at which the thermostat valve begins to open, should satisfy the standard value.

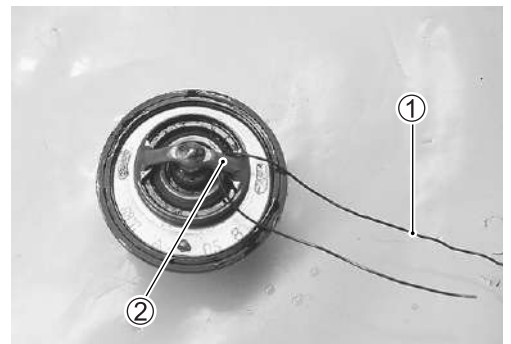

#### **DATA** Thermostat valve opening temperature

Standard: Approx. 88 °C (190 °F)

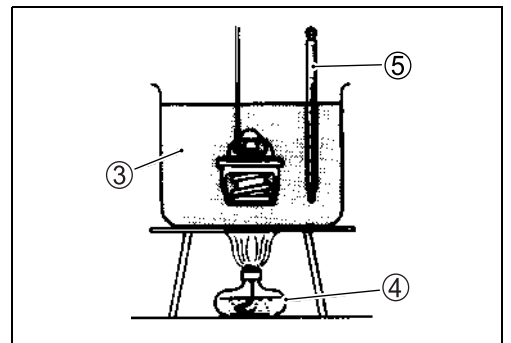

- Keep on heating the water to raise its temperature.
- Just when the water temperature reaches specified value, the thermostat valve should have lifted by at least 8 mm (0.31 in).

**DATA** **Thermostat valve lift** (A)

**Standard:**

**8.0 mm and over at 100 °C (0.31 in and over at 212 °F)**

- A thermostat failing to satisfy either of the two requirements (start-to-open temperature and valve lift) must be replaced.

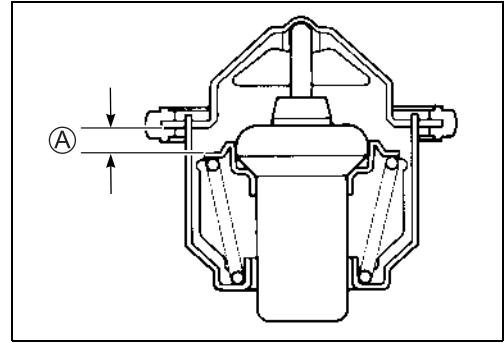

## INSTALLATION

- Install the thermostat.

**NOTE:**

The jiggle valve (A) of the thermostat faces upside.

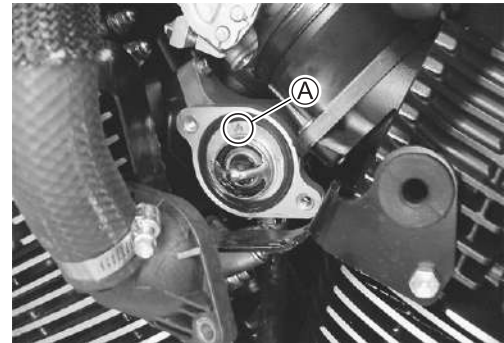

- Install the thermostat cover (1).
- Tighten the thermostat cover bolts.

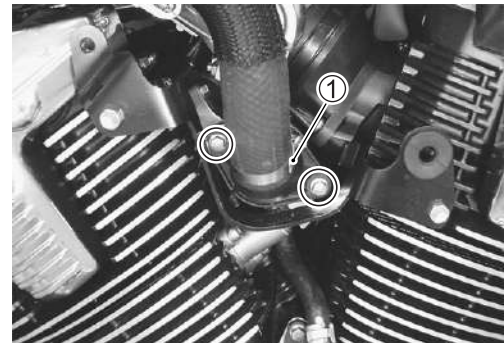

- Install the left air cleaner box.
- Pour engine coolant. (☞ 2-21)

## WATER PUMP

### REMOVAL AND DISASSEMBLY

#### NOTE:

Before draining engine oil and engine coolant, inspect engine oil and coolant leakage between the water pump and crankcase. If engine oil is leaking, visually inspect the oil seal and O-ring. If engine coolant is leaking, visually inspect the mechanical seal and seal washer. (☞ 8-15)

- Remove the secondary gear case cover. (☞ 3-6)
- Drain the engine coolant. (☞ 2-20)
- Drain the engine oil. (☞ 2-17)
- Remove the water outlet pipe mounting bolts.

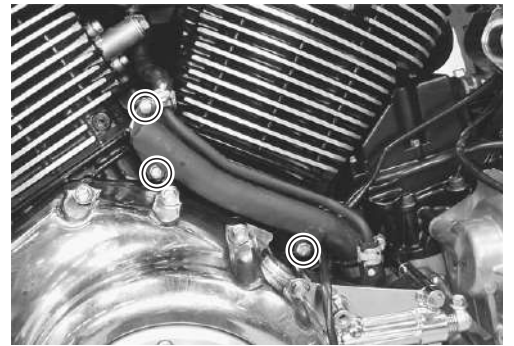

- Disconnect the water hoses.

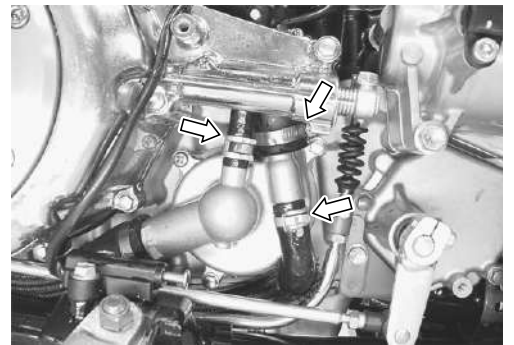

- Remove the water pump ① and disconnect the water hose ②.

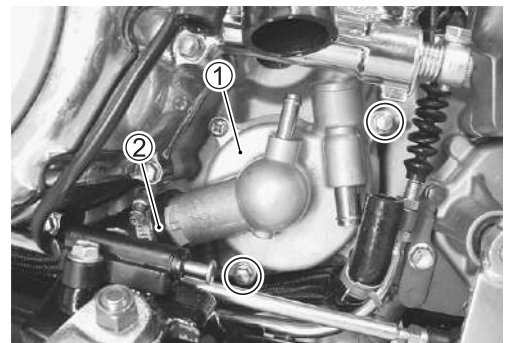

- Remove the water pump cover ③.

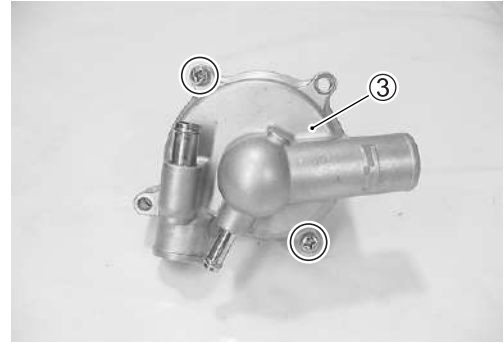

- Remove the impeller securing bolt by holding the impeller with a water pump pliers.



- Remove the mechanical seal ring ④ and rubber seal ⑤ from the impeller.

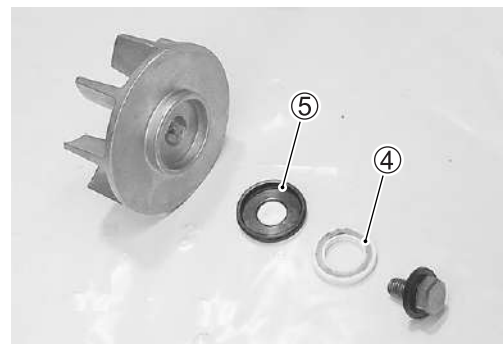

- Remove the impeller shaft ⑥, washer ⑦ and O-ring ⑧.

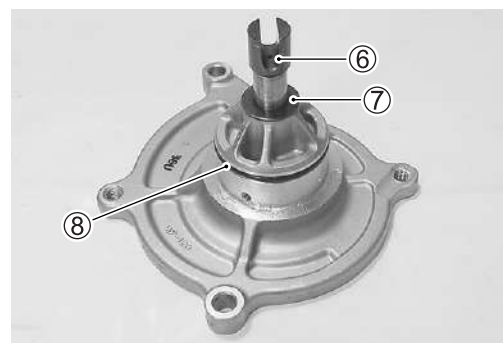

- Remove the mechanical seal with the special tool.

**TOOL** 09921-20240: Bearing remover set (12 mm)

**NOTE:**

*If there is no abnormal condition, the mechanical seal removal is not necessary.*

**CAUTION**

**The removed mechanical seal must be replaced with a new one.**

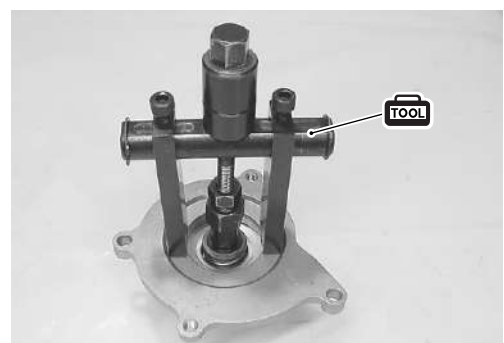



- Remove the oil seal ⑨.

**NOTE:**

*If there is no abnormal condition, the oil seal removal is not necessary.*

**CAUTION**

**The removed oil seal must be replaced with a new one.**

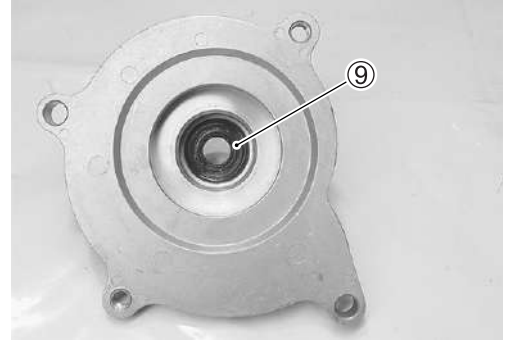
**INSPECTION****MECHANICAL SEAL**

- Visually inspect the mechanical seal for damage, with particular attention given to the sealing face.
- Replace the mechanical seal that shows indications of leakage. Also replace the seal ring if necessary.

**OIL SEAL**

- Visually inspect the oil seal for damage, with particular attention given to the lip.
- Replace the oil seal that shows indications of leakage.

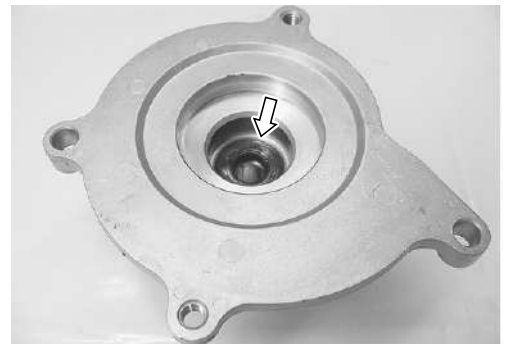
**IMPELLER SHAFT JOURNAL**

- Visually inspect the journal for damage or scratch.
- Replace the water pump body if necessary.

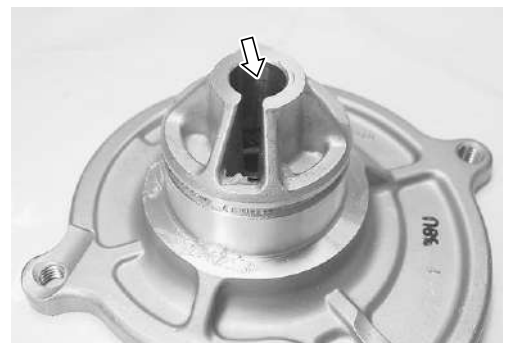
**SEAL WASHER**

- Visually inspect the seal washer for damage, with particular attention given to the sealing face.
- Replace the seal washer that shows indications of leakage.



**CASE**

- Visually inspect the case for damage or scratch.
- Replace the case if necessary.



**REASSEMBLY AND INSTALLATION**

- Install the oil seal with the special tool.

 **09913-70210: Bearing installer set ( $\phi 22$ )**

**NOTE:**

*The stamped mark on the oil seal faces mechanical seal side.*



- Apply a small quantity of the SUZUKI SUPER GREASE “A” to the oil seal lip.

 **99000-25010: SUZUKI SUPER GREASE “A”**  
or equivalent



- Install the new mechanical seal using a suitable size socket wrench.

**NOTE:**

*On the new mechanical seal, the sealer  $\text{\textcircled{A}}$  has been applied.*

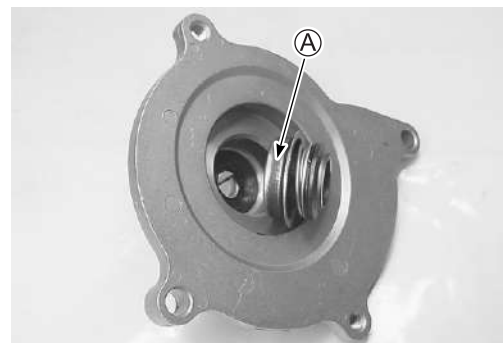

- Apply SUZUKI SUPER GREASE “A” to the impeller shaft and O-ring.

**CAUTION**

**Use the new O-ring to prevent engine oil leakage.**

 99000-25010: SUZUKI SUPER GREASE “A”  
or equivalent

- Install the impeller shaft ①, washer ② and O-ring ③ to the water pump body.
- Install the rubber seal ④ into the impeller.
- After wiping off the oily or greasy matter from the mechanical seal ring, install it into the impeller.

**NOTE:**

The paint marked side ⑤ of mechanical seal ring faces the rubber seal.

- Install the washer ⑤ and seal washer ⑥ onto the impeller securing bolt ⑦.

**NOTE:**

The metal side ③ of seal washer and the curved side ④ of washer face the impeller securing bolt head.

- Install the impeller ⑧ and its securing bolt onto the shaft.
- Tighten the impeller securing bolt to the specified torque.

 Impeller securing bolt: 8 N·m (0.8 kgf-m, 6.0 lb-ft)

**NOTE:**

Before installing the impeller securing bolt, apply a small quantity of the THREAD LOCK to it.

 99000-32050: THREAD LOCK “1342” or equivalent

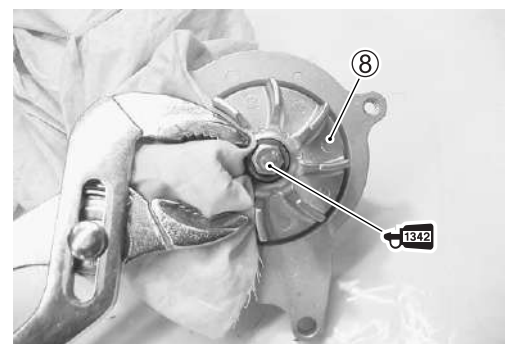
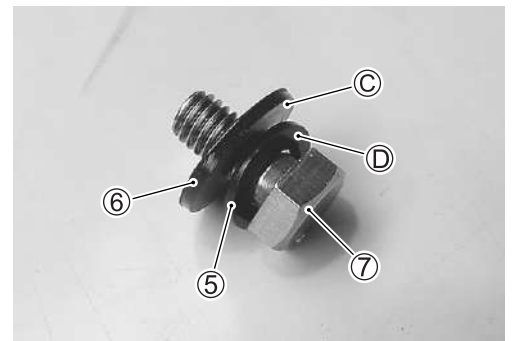
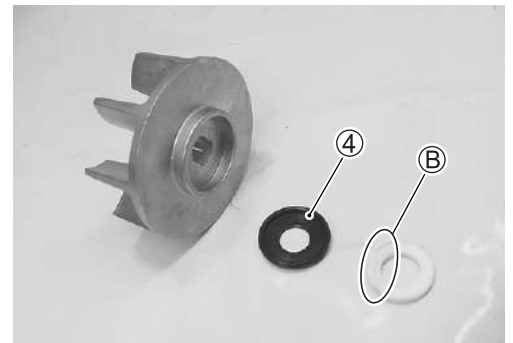
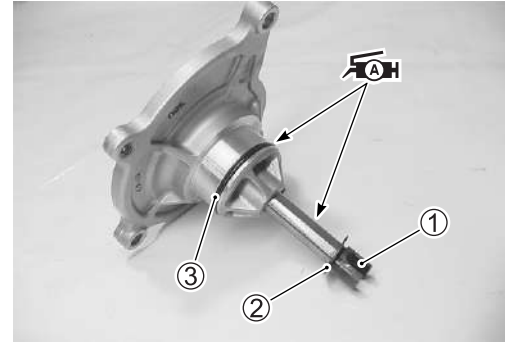

- Install the new O-ring ⑨.

**CAUTION**

**Use the new O-ring to prevent engine coolant leakage.**

**NOTE:**

*Apply engine coolant to the O-ring.*

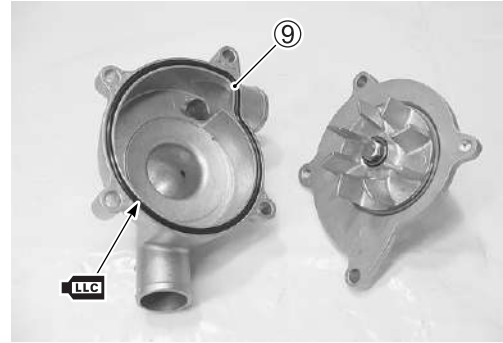

- Tighten the water pump cover screws.

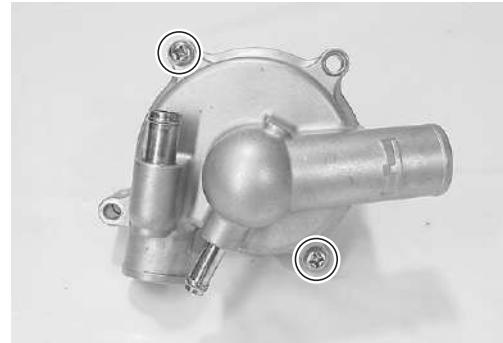

- Install the water pump.

**NOTE:**

*Set the water pump shaft end ⑤ to the oil pump shaft ⑥ as shown.*

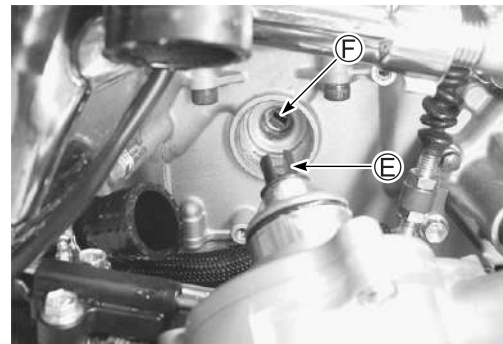

- Connect the water hose ⑩.
- Tighten the water pump mounting bolts to the specified torque.

**🔧 Water pump mounting bolt: 10 N·m (1.0 kgf·m, 7.0 lb-ft)**

- Connect the water hoses. (🔧 11-42)
- Install the water inlet pipe. (🔧 3-86)

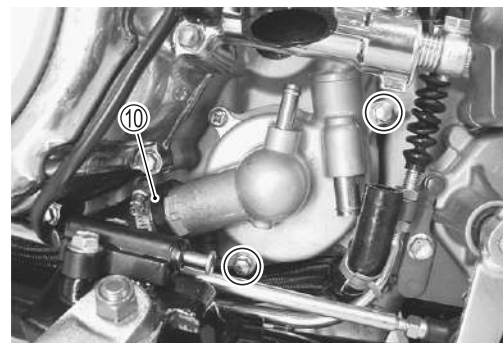

- Pour engine coolant. (🔧 2-21)
- Pour engine oil. (🔧 2-17)
- Install the secondary gear case cover.

# ENGINE LUBRICATION SYSTEM CHART

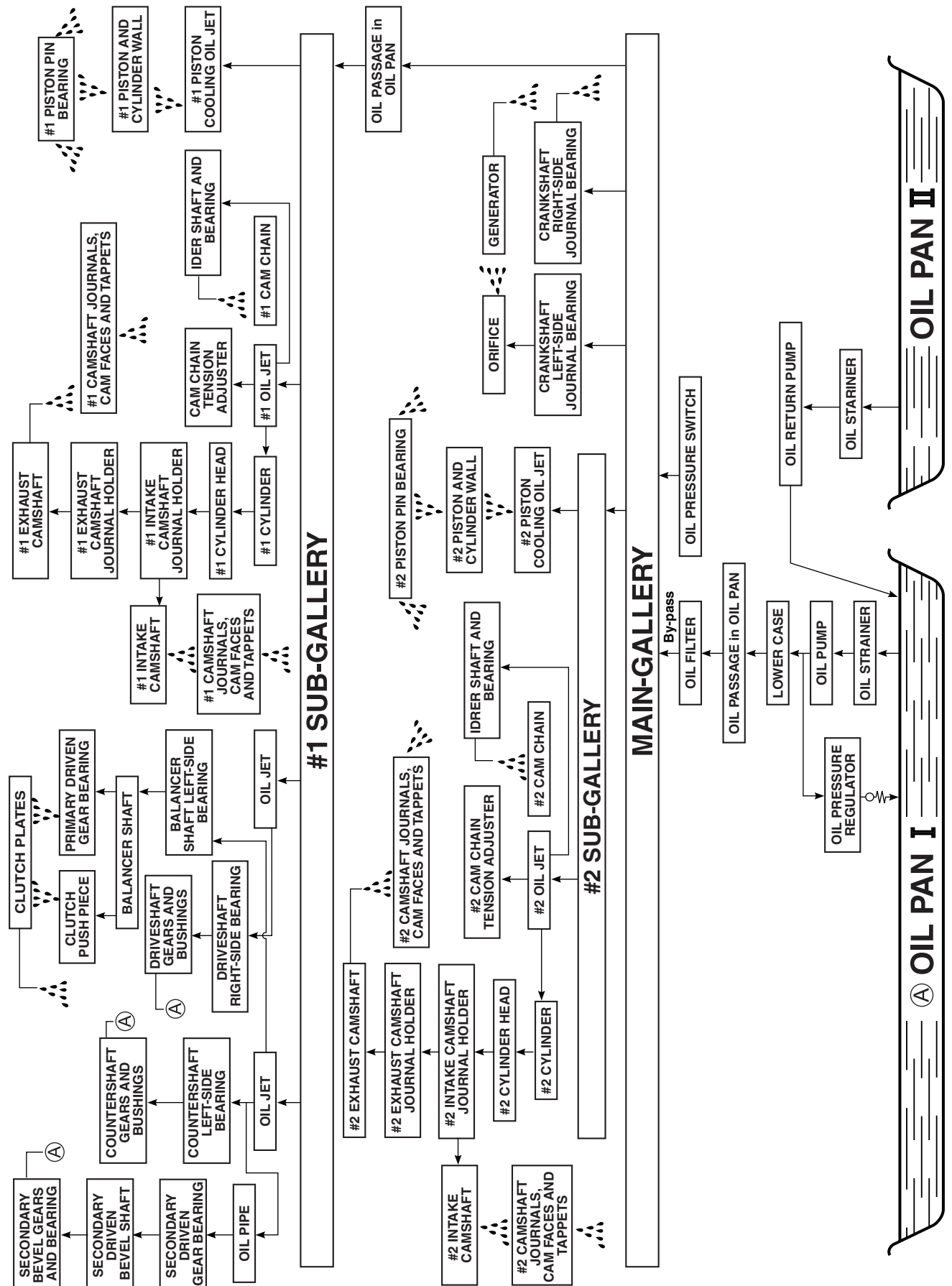

# CHASSIS

## CONTENTS

<b>EXTERIOR PARTS .....</b>	<b>9- 3</b>
<b>FASTENER REMOVAL AND INSTALLATION.....</b>	<b>9- 3</b>
<b>FRONT AND REAR SEAT .....</b>	<b>9- 4</b>
<b>FRAME SIDE COVER .....</b>	<b>9- 5</b>
<b>REAR FRAME COVER .....</b>	<b>9- 5</b>
<b>FRAME HEAD COVER AND RADIATOR COVER.....</b>	<b>9- 6</b>
<b>FRONT WHEEL .....</b>	<b>9- 8</b>
<b>CONSTRUCTION .....</b>	<b>9- 8</b>
<b>REMOVAL .....</b>	<b>9- 9</b>
<b>INSPECTION AND DISASSEMBLY .....</b>	<b>9- 9</b>
<b>REASSEMBLY AND INSTALLATION .....</b>	<b>9-11</b>
<b>FRONT FORK.....</b>	<b>9-14</b>
<b>CONSTRUCTION .....</b>	<b>9-14</b>
<b>REMOVAL AND DISASSEMBLY .....</b>	<b>9-15</b>
<b>INSPECTION .....</b>	<b>9-18</b>
<b>REASSEMBLY .....</b>	<b>9-19</b>
<b>INSTALLATION.....</b>	<b>9-22</b>
<b>STEERING .....</b>	<b>9-23</b>
<b>CONSTRUCTION .....</b>	<b>9-23</b>
<b>REMOVAL .....</b>	<b>9-24</b>
<b>INSPECTION AND DISASSEMBLY .....</b>	<b>9-25</b>
<b>REASSEMBLY .....</b>	<b>9-26</b>
<b>INSTALLATION.....</b>	<b>9-26</b>
<b>STEERING TENSION ADJUSTMENT .....</b>	<b>9-28</b>
<b>HANDLEBARS.....</b>	<b>9-29</b>
<b>CONSTRUCTION .....</b>	<b>9-29</b>
<b>REMOVAL .....</b>	<b>9-30</b>
<b>INSTALLATION.....</b>	<b>9-31</b>
<b>REAR WHEEL.....</b>	<b>9-33</b>
<b>CONSTRUCTION .....</b>	<b>9-33</b>
<b>REMOVAL .....</b>	<b>9-34</b>
<b>DISASSEMBLY .....</b>	<b>9-34</b>
<b>INSPECTION AND DISASSEMBLY .....</b>	<b>9-35</b>
<b>REASSEMBLY AND INSTALLATION .....</b>	<b>9-36</b>
<b>REAR SUSPENSION.....</b>	<b>9-40</b>
<b>CONSTRUCTION .....</b>	<b>9-40</b>
<b>REMOVAL .....</b>	<b>9-41</b>
<b>INSPECTION AND DISASSEMBLY .....</b>	<b>9-42</b>
<b>REAR SHOCK ABSORBER DISPOSAL .....</b>	<b>9-45</b>



# CHASSIS

## CONTENTS

<b>REASSEMBLY .....</b>	<b>9-46</b>
<b>INSTALLATION.....</b>	<b>9-49</b>
<b>SUSPENSION SETTING .....</b>	<b>9-50</b>
<b>FRONT BRAKE.....</b>	<b>9-51</b>
<b>CONSTRUCTION .....</b>	<b>9-51</b>
<b>BRAKE PAD REPLACEMENT .....</b>	<b>9-52</b>
<b>BRAKE FLUID REPLACEMENT .....</b>	<b>9-53</b>
<b>CALIPER REMOVAL .....</b>	<b>9-54</b>
<b>CALIPER DISASSEMBLY .....</b>	<b>9-55</b>
<b>CALIPER INSPECTION .....</b>	<b>9-56</b>
<b>CALIPER REASSEMBLY .....</b>	<b>9-56</b>
<b>CALIPER INSTALLATION .....</b>	<b>9-58</b>
<b>BRAKE DISC INSPECTION.....</b>	<b>9-58</b>
<b>MASTER CYLINDER REMOVAL AND DISASSEMBLY.....</b>	<b>9-59</b>
<b>MASTER CYLINDER INSPECTION.....</b>	<b>9-60</b>
<b>MASTER CYLINDER REASSEMBLY.....</b>	<b>9-60</b>
<b>MASTER CYLINDER INSTALLATION .....</b>	<b>9-61</b>
<b>REAR BRAKE.....</b>	<b>9-62</b>
<b>CONSTRUCTION .....</b>	<b>9-62</b>
<b>BRAKE PAD REPLACEMENT .....</b>	<b>9-63</b>
<b>BRAKE FLUID REPLACEMENT .....</b>	<b>9-64</b>
<b>CALIPER REMOVAL .....</b>	<b>9-65</b>
<b>CALIPER DISASSEMBLY .....</b>	<b>9-65</b>
<b>CALIPER INSPECTION .....</b>	<b>9-66</b>
<b>CALIPER REASSEMBLY .....</b>	<b>9-68</b>
<b>CALIPER INSTALLATION .....</b>	<b>9-69</b>
<b>MASTER CYLINDER REMOVAL.....</b>	<b>9-69</b>
<b>MASTER CYLINDER DISASSEMBLY.....</b>	<b>9-70</b>
<b>MASTER CYLINDER INSPECTION.....</b>	<b>9-71</b>
<b>MASTER CYLINDER REASSEMBLY.....</b>	<b>9-71</b>
<b>MASTER CYLINDER INSTALLATION .....</b>	<b>9-72</b>
<b>TIRE AND WHEEL.....</b>	<b>9-73</b>
<b>TIRE REMOVAL .....</b>	<b>9-73</b>
<b>INSPECTION .....</b>	<b>9-73</b>
<b>VALVE INSPECTION .....</b>	<b>9-74</b>
<b>TIRE INSTALLATION.....</b>	<b>9-75</b>
<b>BALANCER WEIGHT INSTALLATION .....</b>	<b>9-76</b>

## EXTERIOR PARTS

### FASTENER REMOVAL AND INSTALLATION

#### FASTENER (Type A)

##### Removal

- Depress the head of fastener center piece ①.
- Pull out the fastener ②.

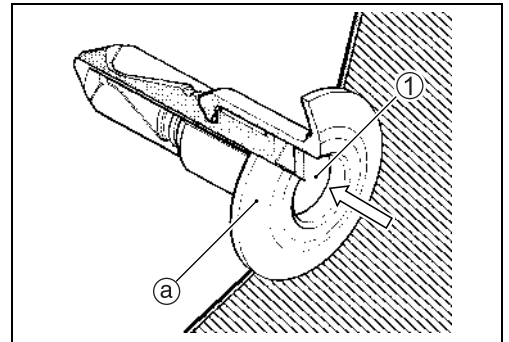

##### Installation

- Let the center piece stick out toward the head so that the pawls ② close.
- Insert the fastener into the installation hole.

##### NOTE:

*To prevent the pawl ② from damage, insert the fastener all the way into the installation hole.*

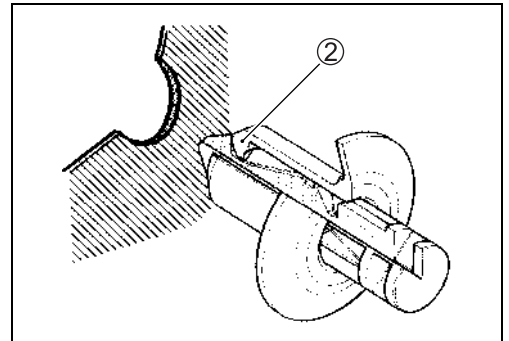

- Push in the head of center piece until it becomes flush with the fastener outside face.

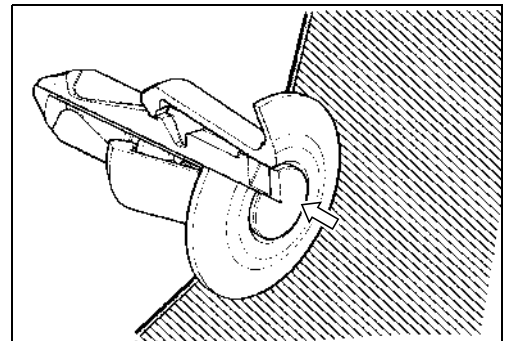

#### FASTENER (Type B)

##### Removal

- Pry up the head of fastener center piece ① with a screw driver.
- Pull out the fastener ②.

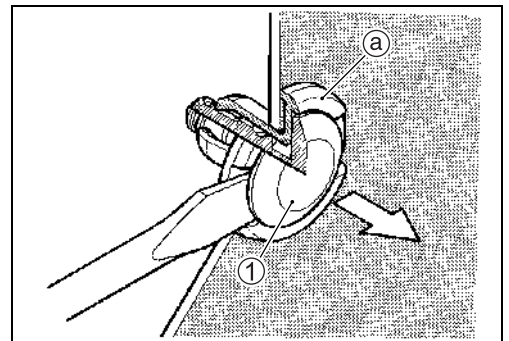

### Installation

- Insert the fastener into the installation hole.

**NOTE:**

To prevent the pawl ② from damage, insert the fastener all the way into the installation hole.

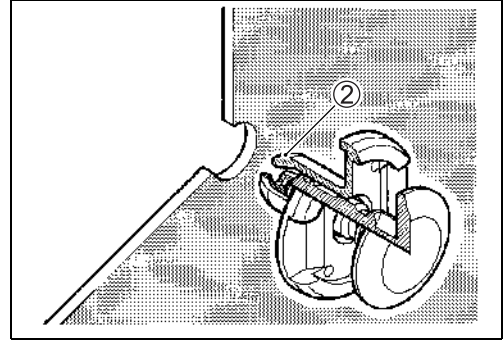

- Push in the head of center piece.

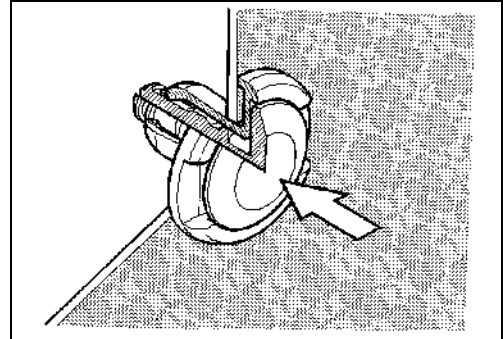

### FRONT AND REAR SEAT REMOVAL

- Remove the front seat with the ignition key.

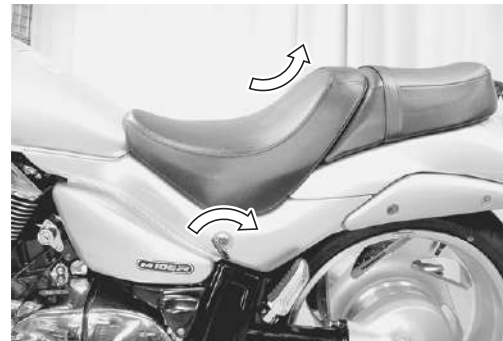

- Remove the bolts and rear seat.



## FRAME SIDE COVER

### REMOVAL

- Remove the front seat. (☞ 9-4)
- Remove the left frame side cover ①.

#### NOTE:

“☆” indicates hook location.



- Disconnect the seat lock cable ②.

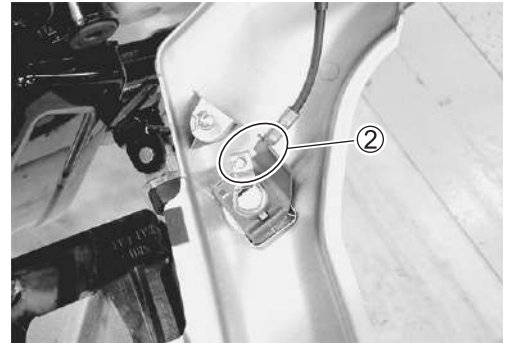

- Remove the right frame side cover ③.

#### NOTE:

“☆” indicates hook location.

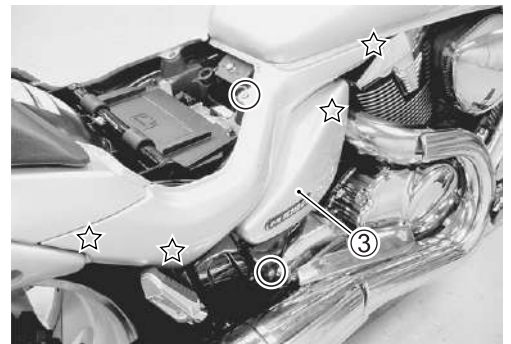

## REAR FRAME COVER

### REMOVAL

- Remove the left and right frame side covers. (☞ above)
- Remove the rear seat. (☞ 9-4)
- Remove the screws.



- Remove the rear frame cover ① and disconnect the rear combination light lead wire coupler.

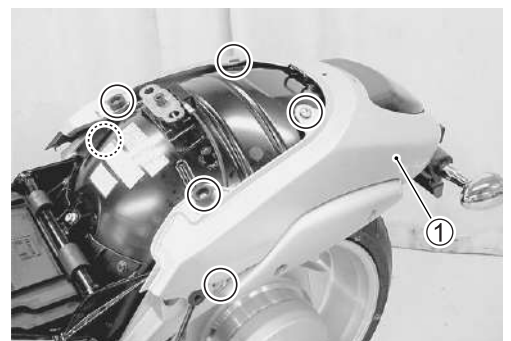

## FRAME HEAD COVER AND RADIATOR COVER

### REMOVAL

- Remove the fuel tank. (☞ 6-3)
- Remove the right frame head cover ① and left frame head cover ②.

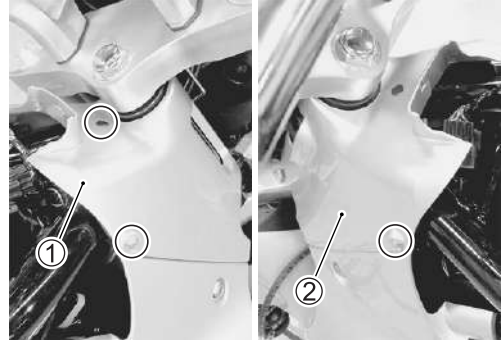

- Remove the right radiator cover ③ by removing the bolt ④ and fastener ⑤.

### NOTE:

“☆” indicates hook location.

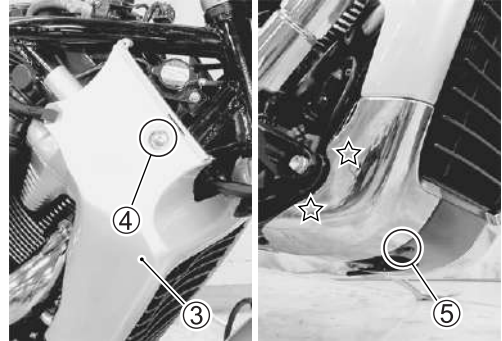

- Remove the left radiator cover ⑥ by removing the bolt ⑦ and fastener ⑧.

### NOTE:

“☆” indicates hook location.

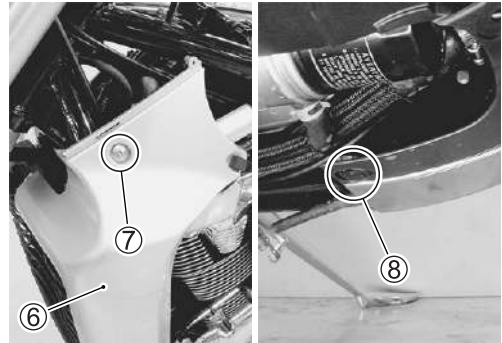

- Remove the radiator bottom cover ⑨.

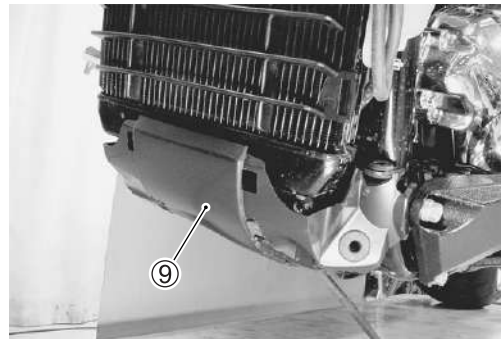



**INSTALLATION**

Install the frame head covers and radiator covers in the reverse order of removal. Pay attention to the following points:

- Install the radiator bottom cover ①.

**NOTE:**

Pass the breather hose ① in the hole ② of a radiator bottom cover.

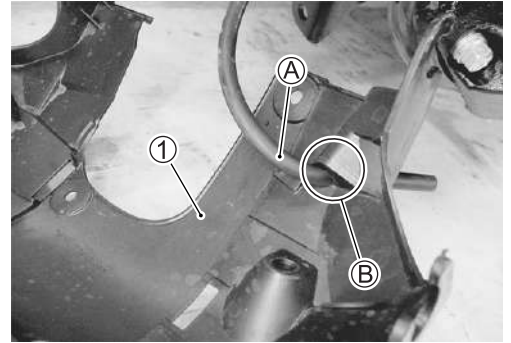

- Frame head cover and radiator cover installation. (☞ 11-46)



# FRONT WHEEL CONSTRUCTION

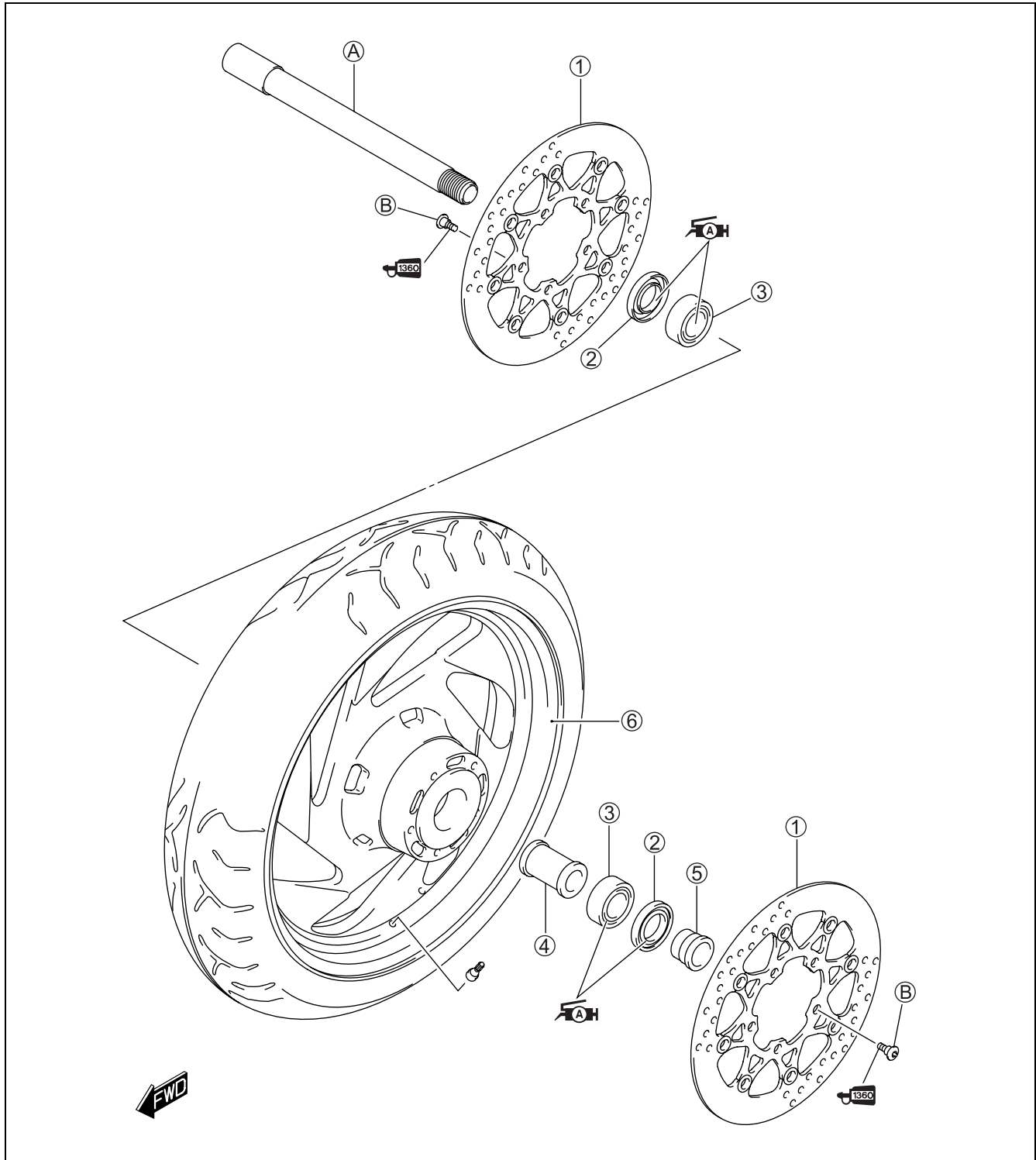

①	Brake disc	⑤	Collar
②	Dust seal	⑥	Front wheel
③	Bearing	Ⓐ	Front axle
④	Spacer	Ⓑ	Brake disc bolt



ITEM	N·m	kgf·m	lb·ft
Ⓐ	100	10.0	72.5
Ⓑ	23	23.0	16.5

## REMOVAL

- Remove the brake calipers ①, left and right.

### CAUTION

Do not operate the brake lever while removing the calipers.

- Loosen the two axle pinch bolts ② on the right front fork leg.
- Loosen the front axle with the special tool.

**TOOL** 09900-18740: Hexagon socket (24 mm)

- Raise the front wheel off the ground and support the motorcycle with a jack or a wooden block.
- Draw out the front axle and remove the front wheel.

### NOTE:

After removing the front wheel, fit the calipers temporarily to the original positions.

- Remove the collar ③.

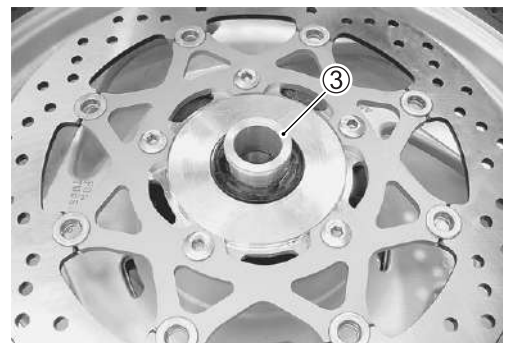
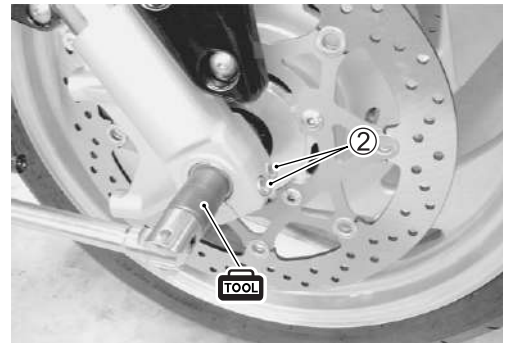
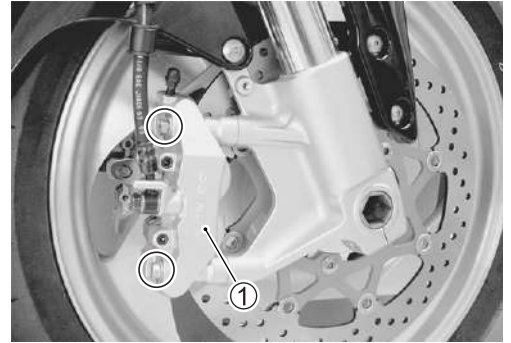

## INSPECTION AND DISASSEMBLY

**WHEEL** (☞ 9-73)

**TIRE** (☞ 2-27 and 9-73)

**BRAKE DISC** (☞ 9-58)

- Remove the brake disc ①.



### WHEEL AXLE

- Using a dial gauge, check the axle for runout and replace it if the runout exceeds the limit.

**TOOL** 09900-20607: Dial gauge (1/100)

09900-20701: Magnetic stand

09900-21304: V-block set (100 mm)

**DATA**

Wheel axle runout (front):

Service Limit: 0.25 mm (0.010 in)

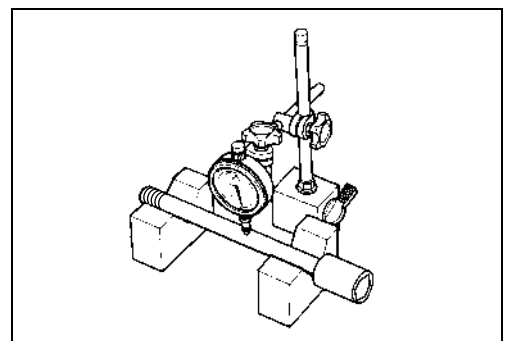

**WHEEL**

- Make sure that the wheel runout checked as shown does not exceed the service limit. An excessive runout is usually due to worn or loosened wheel bearings and can be reduced by replacing the bearings. If bearing replacement fails to reduce the runout, replace the wheel.

**DATA** Wheel runout:

**Service Limit (Axial and Radial): 2.0 mm (0.08 in)**

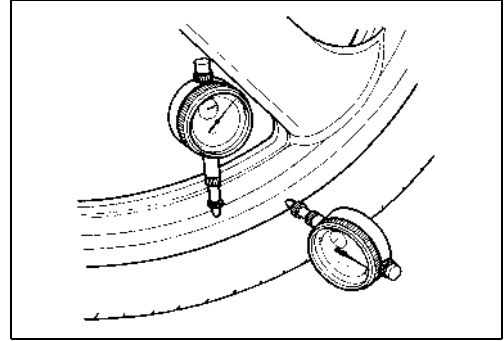
**WHEEL BEARINGS**

- Inspect the play of the wheel bearings by finger while they are in the wheel. Rotate the inner race by finger to inspect for abnormal noise and smooth rotation.
- Replace the bearing in the following procedure if there is anything unusual.

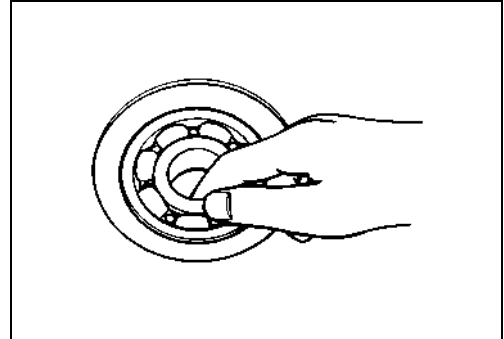

- Remove the dust seals on both sides with the special tool.

**TOOL** 09913-50121: Oil seal remover

**CAUTION**

**The removed dust seals must be replaced with new ones.**



- Remove the wheel bearings on both sides with the special tool.

**TOOL** 09921-20240: Bearing remover set (52 mm)

**CAUTION**

**The removed bearings should be replaced with new ones.**



## REASSEMBLY AND INSTALLATION

Reassemble and install the front wheel in the reverse order of removal and disassembly. Pay attention to the following points:

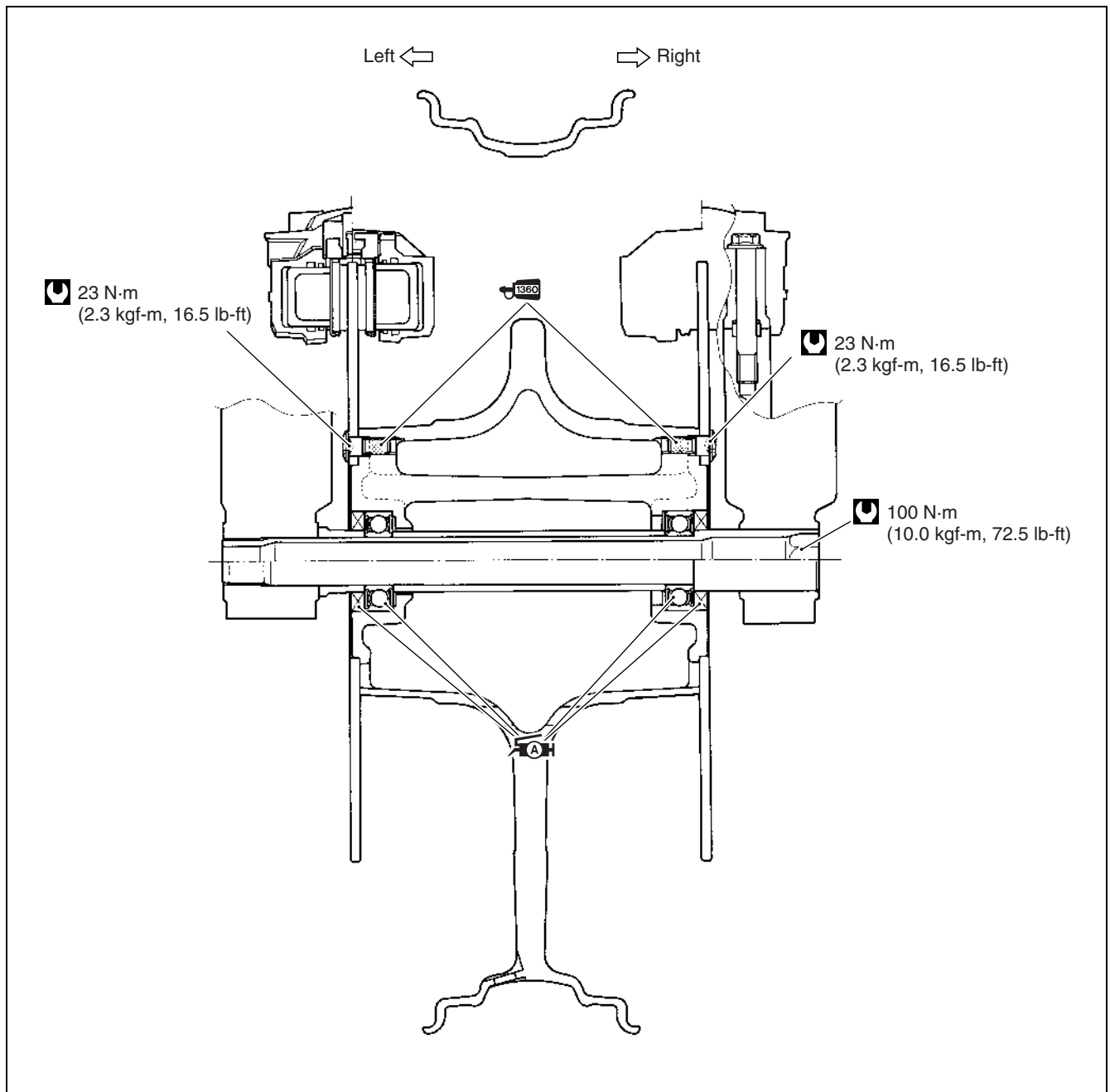

### WHEEL BEARING

- Apply SUZUKI SUPER GREASE "A" to the wheel bearings.

 99000-25010: SUZUKI SUPER GREASE "A"  
or equivalent

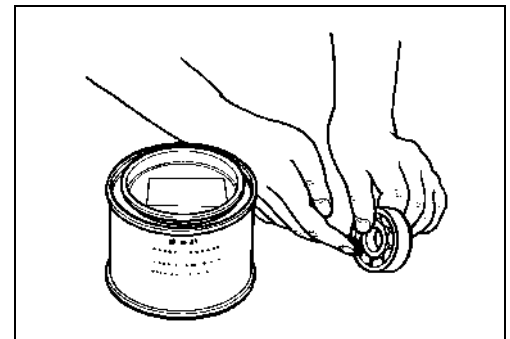

- Install the wheel bearings with the special tools as follows.

**TOOL** 09941-34513: Bearing/Steering race installer set  
 09924-84510: Bearing installer set

**CAUTION**

First install the left wheel bearing, then install the spacer and right wheel bearing.  
 The sealed cover of the bearing must face outside.

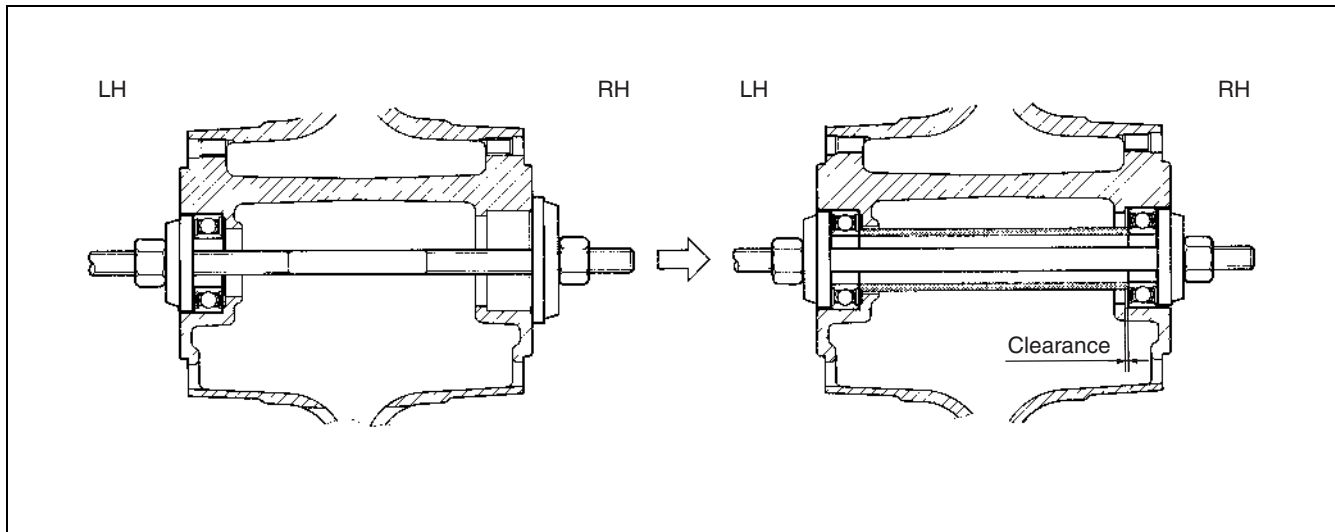
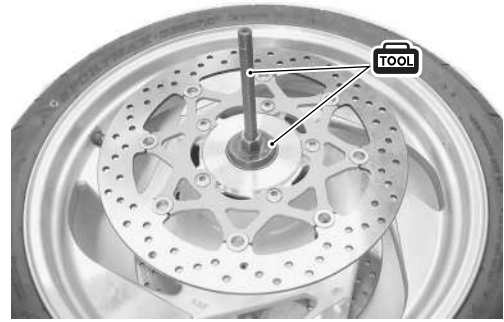

- Install the dust seal with the special tool.

**TOOL** 09913-70210: Bearing installer set (52 mm)

- Apply SUZUKI SUPER GREASE “A” to the dust seal lip.

**AH** 99000-25010: SUZUKI SUPER GREASE “A”  
 or equivalent



**BRAKE DISC**

- Make sure that the brake disc is clean and free of any greasy matter.
- Apply THREAD LOCK SUPER to the disc mounting bolts and tighten them to the specified torque.

**W** Brake disc bolt: 23 N·m (2.3 kgf·m, 16.5 lb·ft)

**1360** 99000-32130: THREAD LOCK SUPER “1360”  
 or equivalent

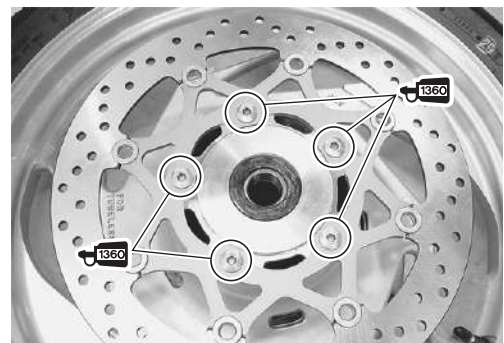



**WHEEL**

- Install the collar ① in the left side.
- Install the front wheel with the front axle and tighten the front axle with hand temporarily.

**⚠ WARNING**

The directional arrow on the tire should point to the wheel rotation, when remounting the wheel.

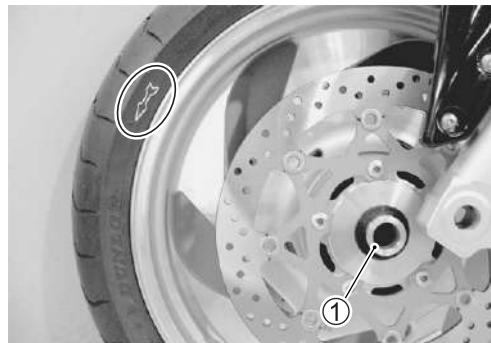
**FRONT AXLE**

- Tighten the front axle to the specified torque.

 09900-18740: Hexagon socket (24 mm)

 Front axle bolt: 100 N·m (10.0 kgf-m, 72.5 lb-ft)

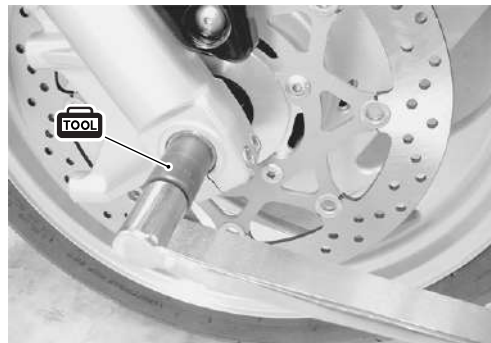
**BRAKE CALIPER**

- Tighten the brake caliper mounting bolts, left and right to the specified torque.

 Front brake caliper mounting bolt:  
39 N·m (3.9 kgf-m, 28.0 lb-ft)

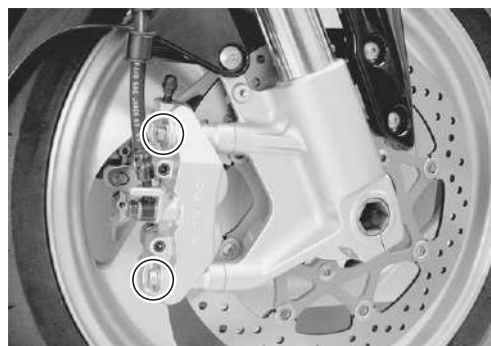

- Move the front fork up and down 4 or 5 times.



- Tighten two axle pinch bolts on the right front fork leg to the specified torque.

 Front axle pinch bolt: 23 N·m (2.3 kgf-m, 16.5 lb-ft)

**NOTE:**

After remounting the front wheel, pump the brake lever a few times to check for proper brake operation.





# FRONT FORK CONSTRUCTION

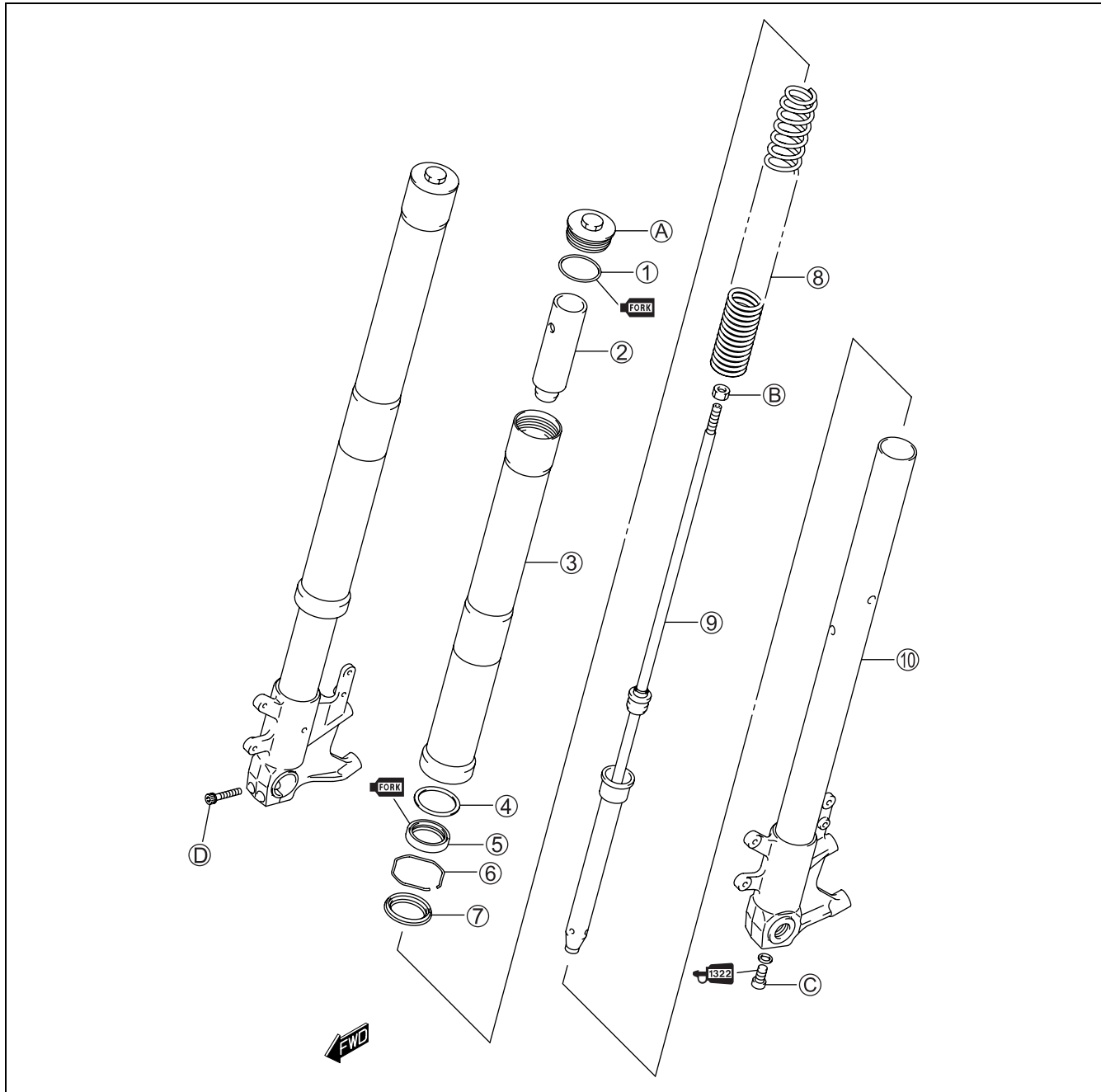

①	O-ring	⑥	Oil seal stopper ring	Ⓐ	Front fork cap bolt
②	Spacer	⑦	Dust seal	Ⓑ	Inner rod lock nut
③	Outer tube	⑧	Spring	Ⓒ	Damper rod bolt
④	Oil seal retainer	⑨	Inner rod/Damper rod (cartridge)	Ⓓ	Front axle pinch bolt
⑤	Oil seal	⑩	Inner tube		



ITEM	N·m	kgf·m	lb·ft
Ⓐ	23	2.3	16.5
Ⓑ	15	1.5	11.0

ITEM	N·m	kgf·m	lb·ft
Ⓒ	40	4.0	29.0
Ⓓ	23	2.3	16.5

## REMOVAL AND DISASSEMBLY

- Remove the front wheel. (👉 9-9)
- Remove the bolts, left and right and front fender.



- Remove the fasteners ① and bolts ②.
- Remove the head light assembly and disconnect the couplers.

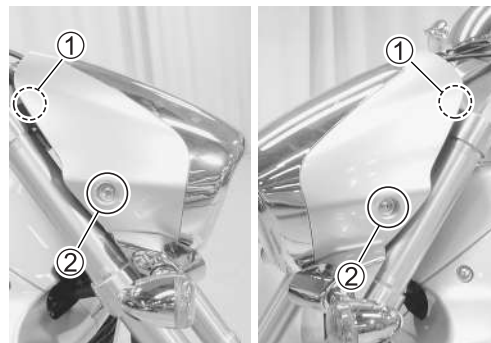

- Loosen the front fork upper clamp bolt ③.

### NOTE:

*Slightly loosen the front fork cap bolts ④ before loosening the lower clamp bolts to facilitate later disassembly.*



- Loosen the front fork lower clamp bolts.
- Remove the front fork.

### NOTE:

*Hold the front fork by the hand to prevent sliding out of the steering stem.*



- Separate the front fork cap bolt from the front fork outer tube.
- Compress the front fork spring with the special tool ① and insert the special tool ② between the lock nut and the spacer.

 **09940-94930: Front fork spacer holder ①**  
**09940-94922: Stopper plate ② (11 mm)**

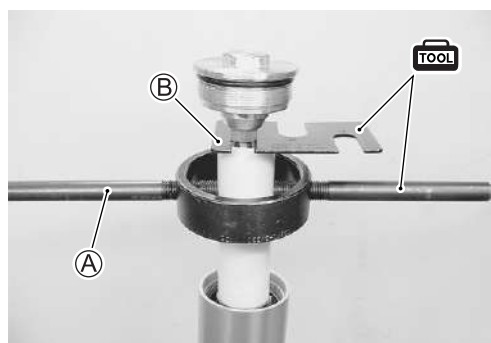

- Remove the front fork cap bolt ⑤ from the inner rod by loosening the lock nut.
- Remove the special tools.

**CAUTION**

After removing the front fork cap bolt ⑤, avoid holding the outer tube vertically by hand to prevent the inner tube from falling and damaged.

- Remove the spacer ⑥ and spring ⑦.

- Remove the front axle pinch bolts.

- Invert the front fork and stroke the inner rod several times to let out fork oil.
- Under the inverted condition of front fork, drain oil completely by holding the fork for a while.

- Remove the damper rod bolt with the special tool.

 09940-30221: Front fork assembling tool

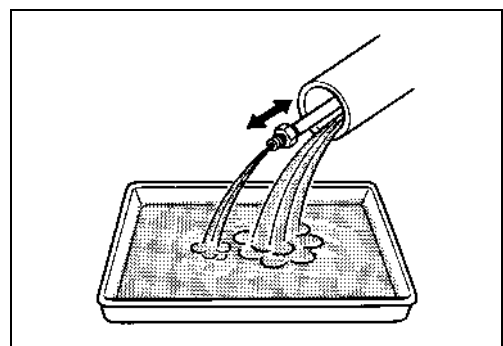
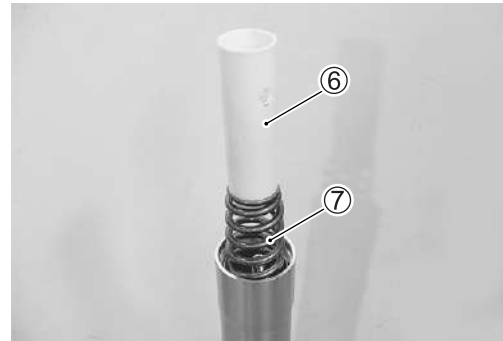
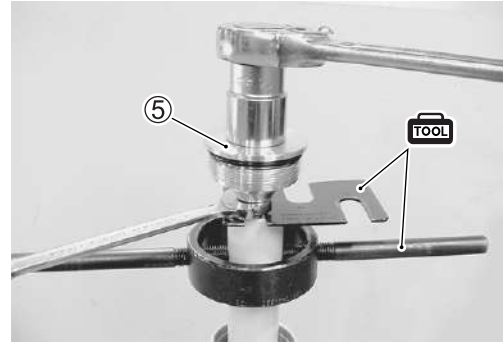

- Remove the inner rod/damper rod (cartridge) ⑧.

**CAUTION**

**Do not disassemble the inner rod/damper rod (cartridge).**

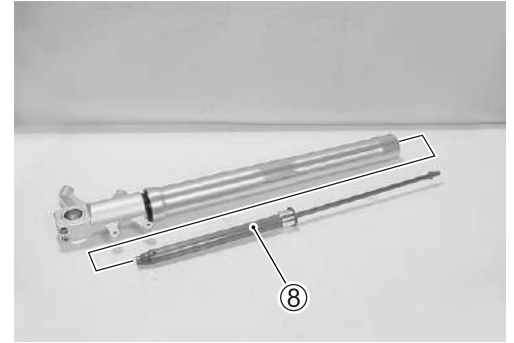

- Extract the outer tube from the inner tube.

**NOTE:**

*Be careful not to damage the “ANTI-FRICTION” metals.*

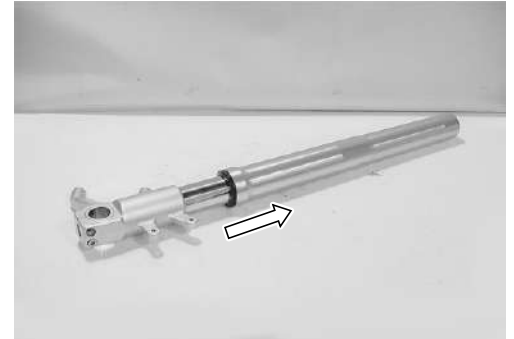

- Remove the dust seal ⑨ and oil seal stopper ring ⑩.

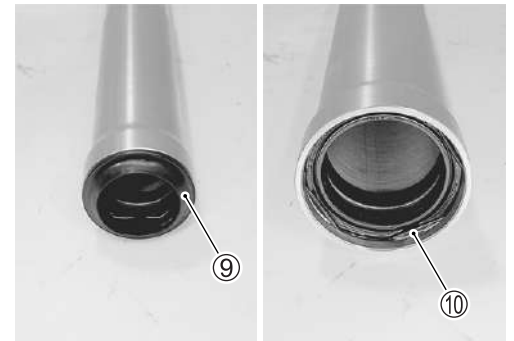

- Remove the oil seal with the special tool.

**TOOL 09913-50121: Oil seal remover**

**CAUTION**

**The removed oil seal must be replaced with a new one.**

- Remove the oil seal retainer ⑪.

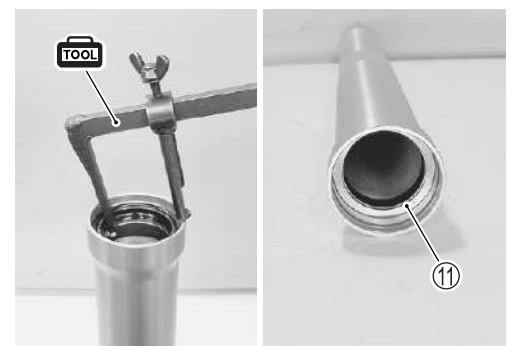

## INSPECTION

### INNER AND OUTER TUBES

- Inspect the inner tube outer surface and outer tube inner surface for scratches.
- Inspect the “ANTI-FRICTION” metal surfaces for scratches.
- If any defects are found, replace them with a new one.

#### CAUTION

Do not remove the “ANTI-FRICTION” metal (A) and (B).

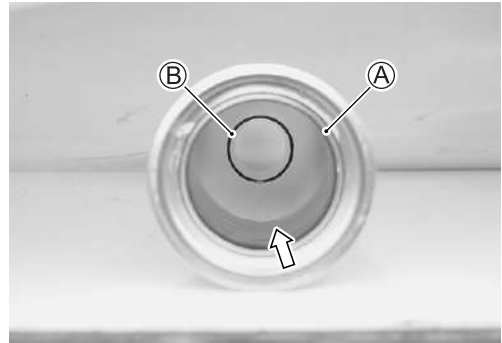
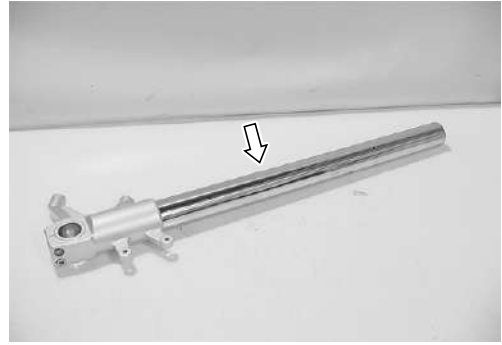

### FORK SPRING

- Measure the fork spring free length.
- If it is shorter than the service limit, replace it with a new one.

**DATA** Front fork spring free length:  
Service Limit: 391 mm (15.4 in)

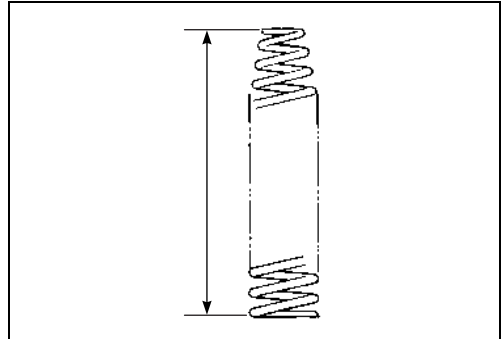

### DAMPER ROD

- Move the inner rod by hand to examine it for smoothness.
- If any defects are found, replace inner rod/damper rod (cartridge) with a new one.

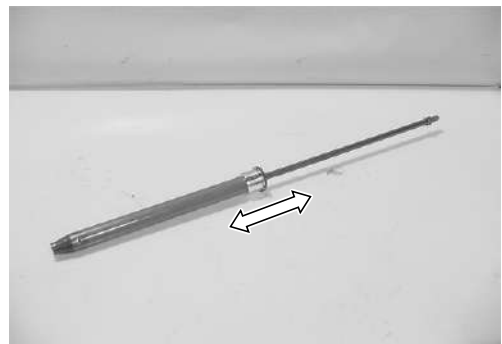

## REASSEMBLY

Reassemble the front fork in the reverse order of disassembly. Pay attention to the following points:

### OIL SEAL AND DUST SEAL

- Install the dust seal, oil seal stopper ring, oil seal and oil seal retainer onto the inner tube.
- ① Dust seal
  - ② Oil seal stopper ring
  - ③ Oil seal
  - ④ Oil seal retainer

#### CAUTION

- \* When installing the oil seal to outer tube, be careful not to damage the oil seal lip.
- \* Do not use solvents for washing to prevent oil seal damage.
- \* Apply fork oil to the Anti-friction metals and lip of the oil seal.
- \* Make sure that the oil seal stopper ring has been fitted securely.

- Insert the inner tube into the outer tube and fit the oil seal and dust seal with the special tool.

 **09940-52861: Front fork oil seal installer**

*NOTE:*

*Stamped mark on the oil seal should face outside.*

### DAMPER ROD BOLT

- Insert the inner rod/damper rod (cartridge) into the inner tube.
- Apply THREAD LOCK SUPER to the damper rod bolt.

 **99000-32110: THREAD LOCK SUPER "1322"**  
or equivalent

#### CAUTION

Use a new damper rod bolt gasket ① to prevent oil leakage.

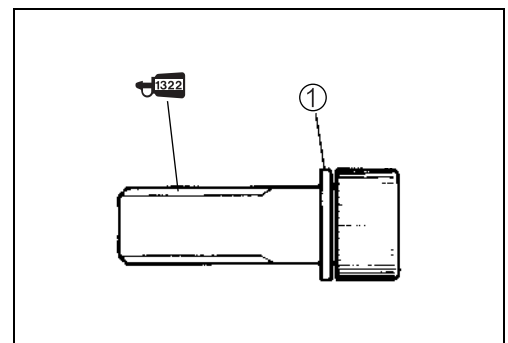
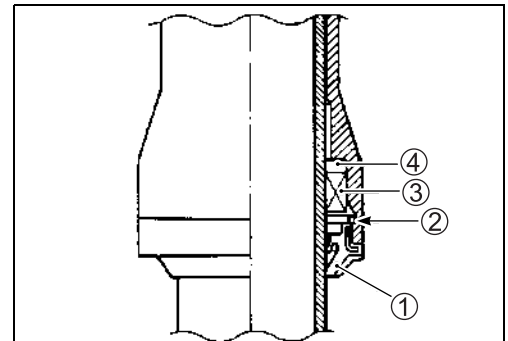
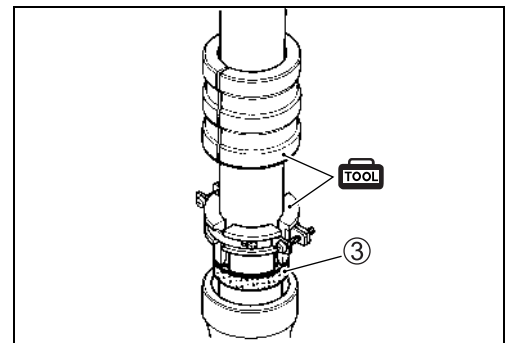
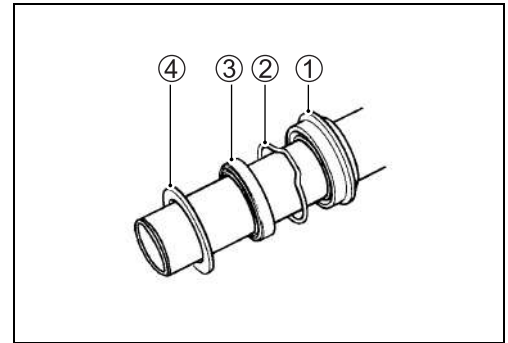



- Tighten the damper rod bolt to the specified torque with the special tool.

**TOOL** 09940-30221: Front fork assembling tool

**TOOL** Damper rod bolt: 40 N·m (4.0 kgf·m, 29.0 lb-ft)



## FORK OIL

- Place the front fork vertically without spring.
- Compress it fully.
- Pour specified front fork oil up to the top level of the outer tube.

**FORK** 99000-99044-L01: SUZUKI FORK OIL L01  
or an equivalent

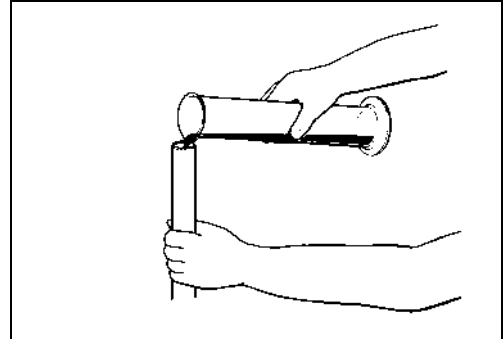

- Move the inner rod slowly with the special tool ten times and more until no more bubbles come out from the oil.

**TOOL** 09940-52841: Inner rod holder

### NOTE:

Refill front fork oil up to the top of the outer tube so that bubbles are visible while bleeding air.

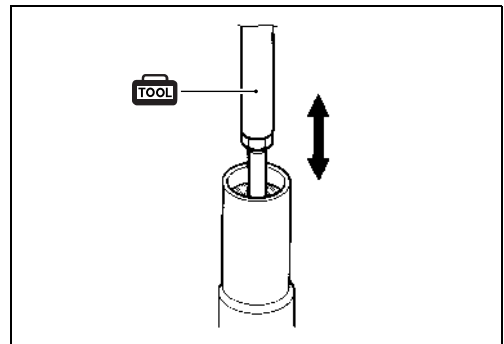

- Refill specified front fork oil up to the top level of the outer tube again. Move the outer tube up and down several strokes until no more bubbles come out from the oil.
- Keep the front fork vertically and wait 5 – 6 minutes.

### NOTE:

\* Always keep oil level over the cartridge top end, or air may enter the cartridge during this procedure.

\* Take extreme care so as to pump out air completely.

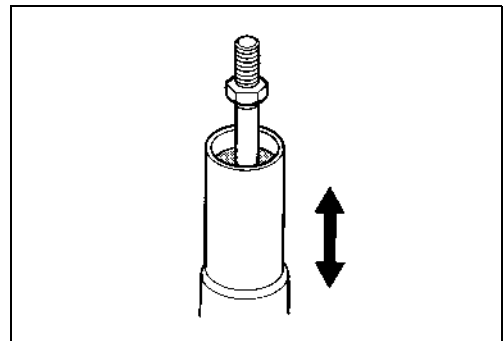

- Hold the front fork vertically and adjust fork oil level with the special tool.

### NOTE:

When adjusting the fork oil level, compress the outer tube fully without the fork spring.

**DATA** Fork oil level: 133 mm (5.2 in)

**TOOL** 09943-74111: Front fork oil level gauge

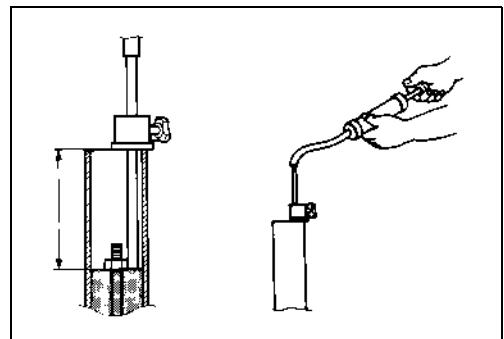

**FRONT FORK INNER ROD LOCK NUT**

- Loosen the lock nut ① to the bottom of inner rod threads.

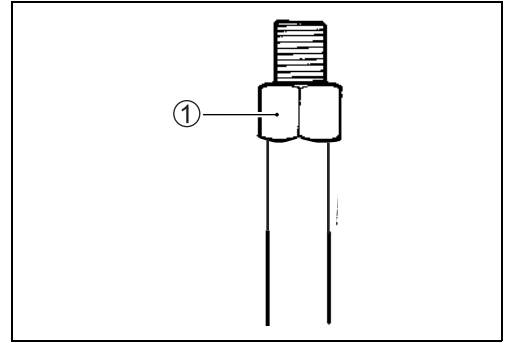
**FORK SPRING**

- Install the fork spring as shown in the illustration.

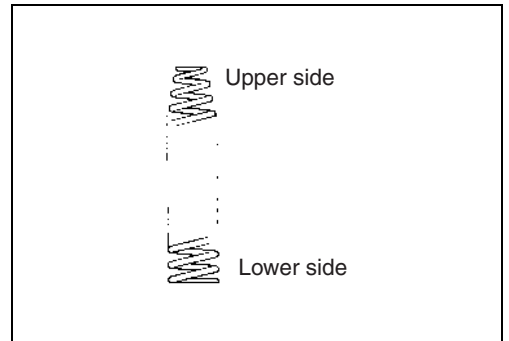

- Install the spring ① and spacer ②.

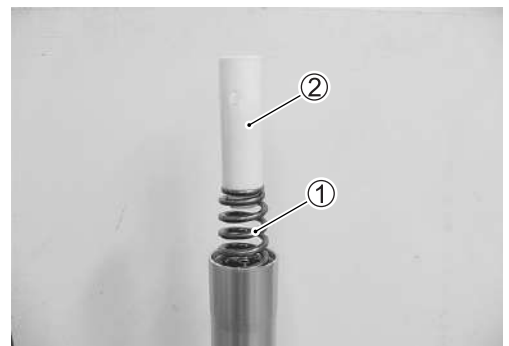
**FRONT FORK CAP BOLT**

- Pull up the inner rod with the special tool (A).
- Compress the spring with the special tool (B) and then insert the special tool (C) between the lock nut and the spacer.

- TOOL** 09940-52841: Inner rod holder (A)
- 09940-94930: Front fork spacer holder (B)
- 09940-94922: Stopper plate (C) (11 mm)

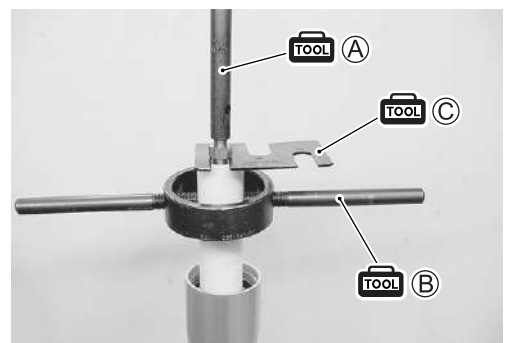

- Slowly turn the cap bolt ① until the inner rod is lightly seated.
- Hold the cap bolt ① and tighten the lock nut ② to the specified torque.

**Inner rod lock nut: 15 N·m (1.5 kgf·m, 11.0 lb-ft)**

- Remove the special tools.
- Fit the O-ring to the front fork cap bolt and apply fork oil.

**CAUTION**

Use a new O-ring to prevent oil leakage.

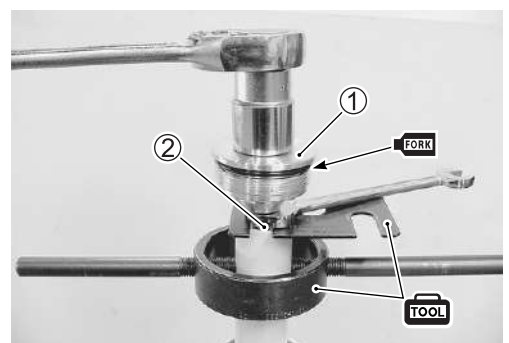

## INSTALLATION

Install the front fork in the reverse order of removal. Pay attention to the following points:

- Install the front fork to the steering stem and steering stem upper bracket.
- Install the top of outer tube 5 mm (0.2 in) higher than the upper surface of the steering stem upper bracket and tighten the front fork lower clamp bolts ① to the specified torque.



### Front fork lower clamp bolt: 23 N·m (2.3 kgf-m, 16.5 lb-ft)

- Tighten the front fork cap bolt ② to the specified torque and recheck the front fork outer tube upper surface height.

### Front fork cap bolt: 23 N·m (2.3 kgf-m, 16.5 lb-ft)

- Tighten the front fork upper clamp bolt ③.

### Front fork upper clamp bolt: 23 N·m (2.3 kgf-m, 16.5 lb-ft)

- Remount the front wheel. ( 9-13)
- Cable routing ( 11-38)
- Front brake hose routing ( 11-39)

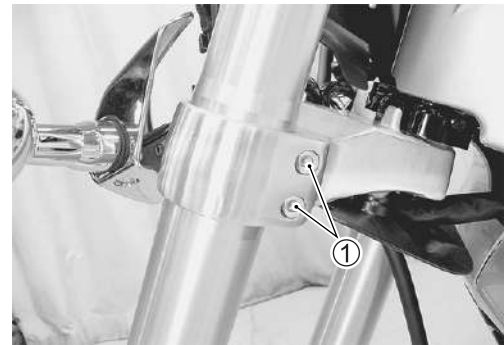
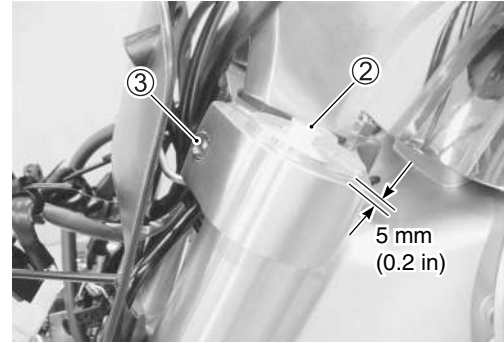

# STEERING CONSTRUCTION

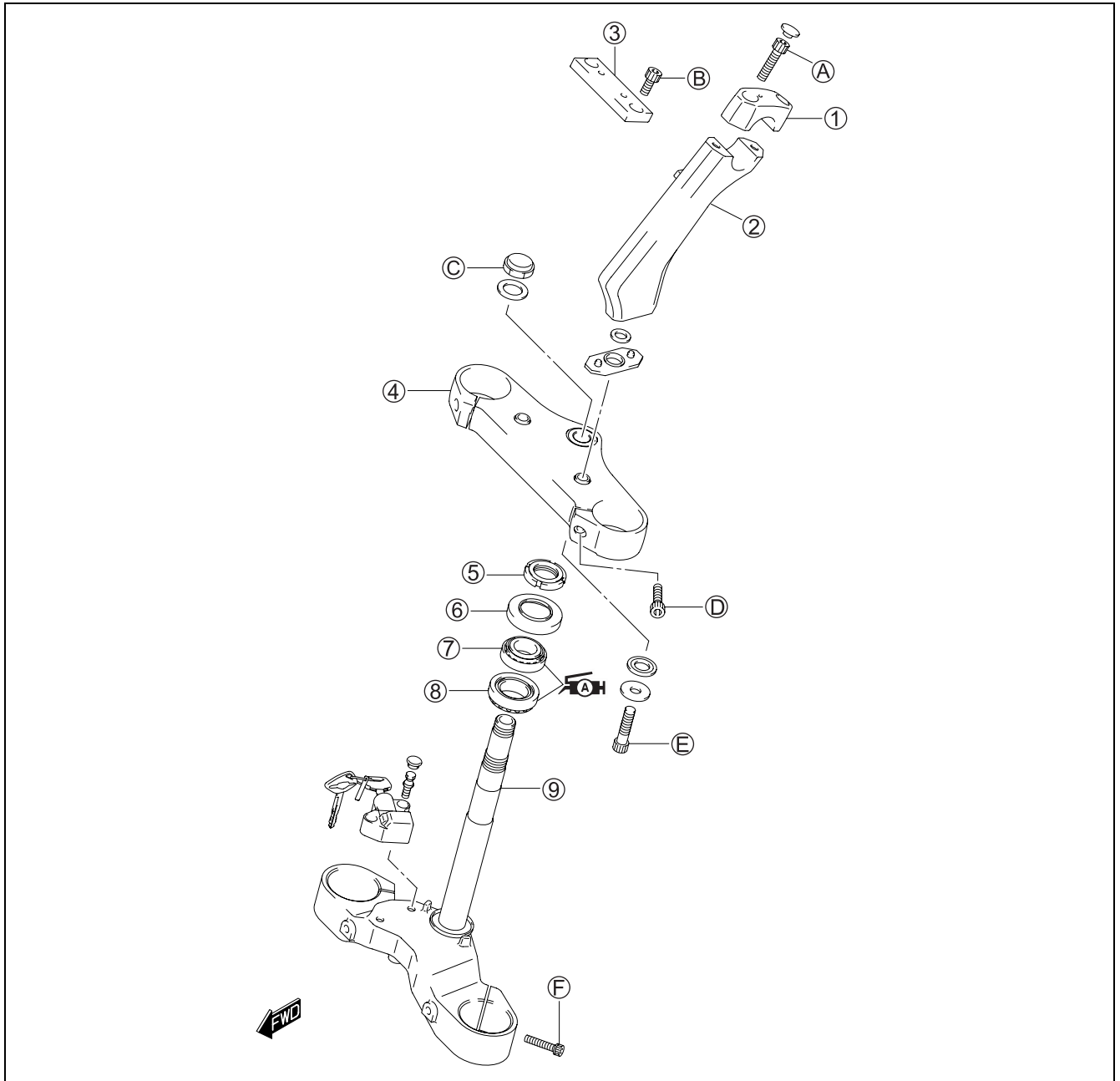

①	Handlebar clamp	⑥	Dust seal	ⓑ	Handlebar holder bracket bolt
②	Handlebar clamp holder	⑦	Steering stem upper bearing	ⓒ	Steering stem head nut
③	Handlebar holder bracket	⑧	Steering stem lower bearing	ⓓ	Front fork upper clamp bolt
④	Steering stem upper bracket	⑨	Steering stem	ⓔ	Handlebar holder bolt
⑤	Steering stem nut	Ⓐ	Handlebar clamp bolt	ⓕ	Front fork lower clamp bolt



ITEM	N-m	kgf-m	lb-ft
Ⓐ	23	2.3	16.5
ⓑ	23	2.3	16.5
ⓒ	90	9.0	65.0

ITEM	N-m	kgf-m	lb-ft
ⓓ	23	2.3	16.5
ⓔ	85	8.5	61.5
ⓕ	23	2.3	16.5

## REMOVAL

- Remove the front forks. (☞ 9-15)
- Remove the handlebar. (☞ 9-30)
- Remove the tachometer. (☞ 10-32)
- Remove the turn signal mounting bolts ①, brake hose guide bolts ② and brake hose mounting bolt ③.

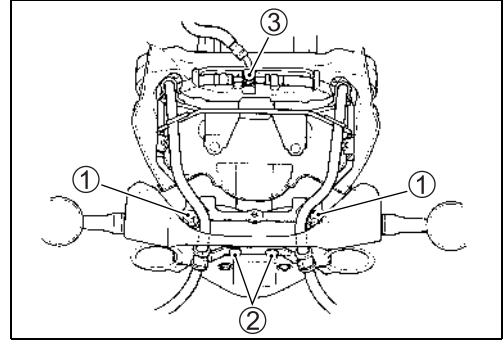

- Remove the steering stem head nut ④ and washer.
- Remove the steering stem upper bracket ⑤.



- Remove the steering stem nut with the special tool.

**TOOL** 09940-14911: Steering stem nut wrench

- Draw out the steering stem lower bracket.

### NOTE:

Hold the steering stem lower bracket by hand to prevent it from falling.



- Remove the dust seal ⑥ and steering stem upper bearing ⑦.

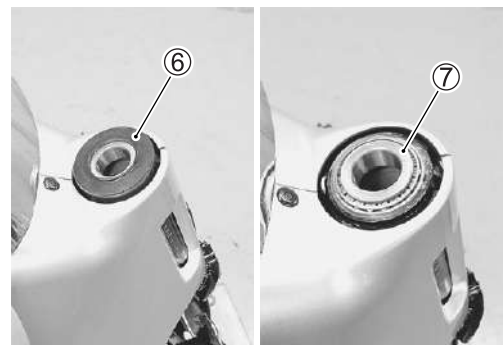

- Remove the handlebar holder bracket ⑧.

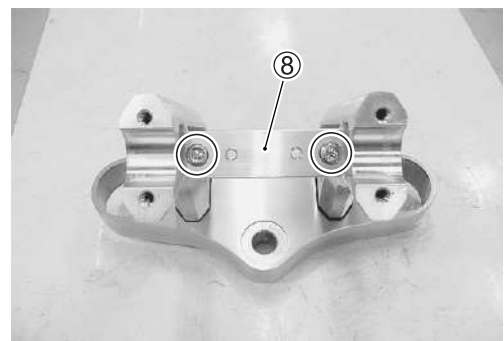

- Remove the handlebar holder ⑨ from the steering stem upper bracket.

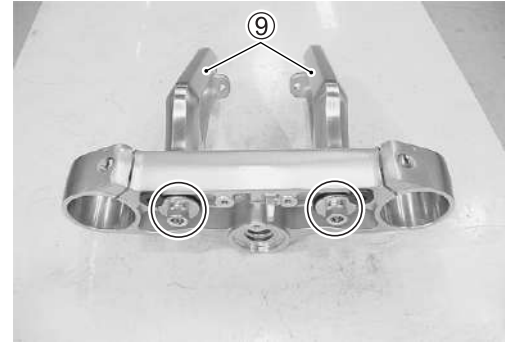

- Remove the following parts.

- ⑩ Bolt
- ⑪ Rubber cushion
- ⑫ Rubber washer
- ⑬ Washer

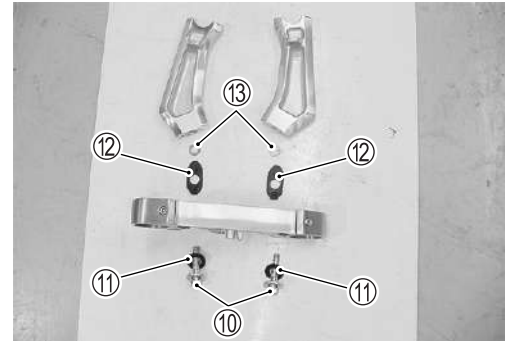

## INSPECTION AND DISASSEMBLY

Inspect the removed parts for the following abnormalities.

- \* Handlebars distortion
- \* Distortion of the steering stem.
- \* Bearing wear or damage
- \* Abnormal noise of bearing

If any abnormal points are found, replace defective parts with the new ones.



- Remove the steering stem lower bearing with a chisel.

### CAUTION

The removed lower bearing must be replaced with a new one.

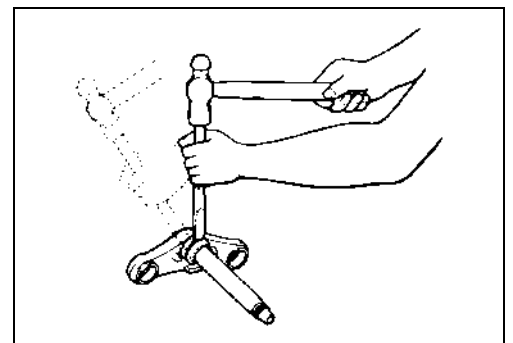

- Drive out the steering stem bearing outer races (upper and lower) using the steel rod.

### CAUTION

The removed bearing outer race must be replaced with a new one.

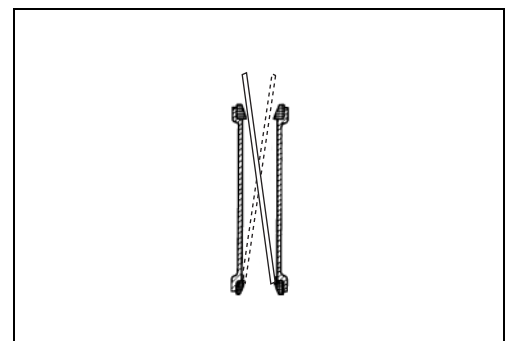



- Inspect handlebar bushings for damage.
- If any damage is found, replace the handlebar bushing with a new one.

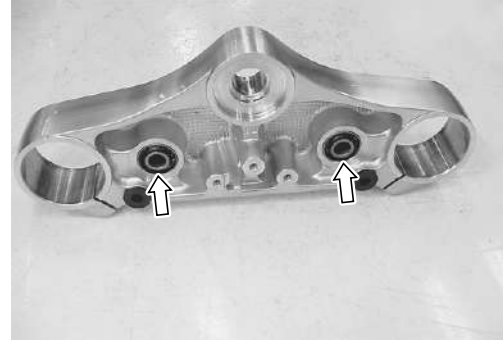

## REASSEMBLY

Reassemble the steering stem in the reverse order of disassembly. Pay attention to the following points:

### OUTER RACE

- Press in the upper and lower bearing outer races with the special tools.

 **09941-34513: Steering outer race installer set**

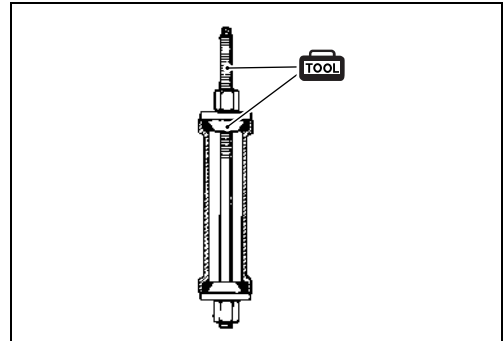

### INNER RACE

- Press in the lower bearing with the special tool.

 **09925-18011: Steering bearing installer**



## INSTALLATION

Install the steering stem in the reverse order of removal. Pay attention to the following points:

### BEARING

- Apply SUZUKI SUPER GREASE “A” to the bearings.

 **99000-25010: SUZUKI SUPER GREASE “A”**  
or equivalent

- Install the upper bearing ① to the steering stem.

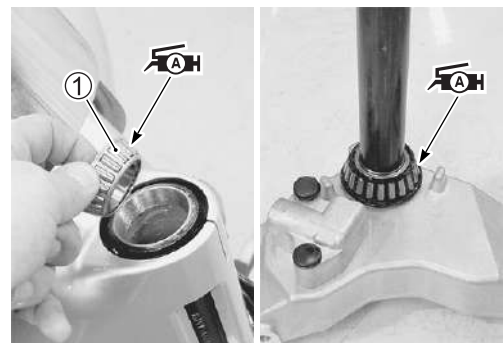

### STEERING STEM NUT

- Install the dust seal ①.
- Install the steering stem ②.
- Install the steering stem nut ③ as shown.

#### NOTE:

The flange side  of the steering stem must face lower.

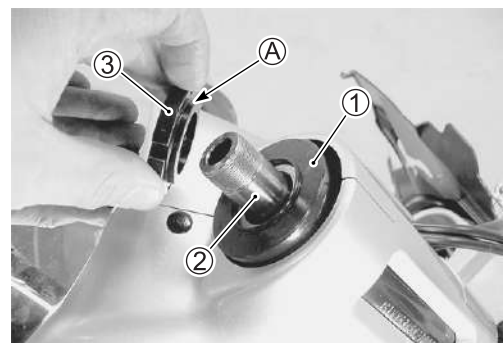

- Tighten the steering stem nut to the specified torque with the special tool.

 **09940-14911: Steering stem nut wrench**

 **Steering stem nut: 45 N·m (4.5 kgf·m, 32.5 lb-ft)**



- Turn the steering stem lower bracket about five or six times to the left and right so that the bearing will be seated properly.
- Loosen the stem nut by 1/4 – 1/2 turn.

**NOTE:**

*This adjustment will vary from motorcycle to motorcycle.*

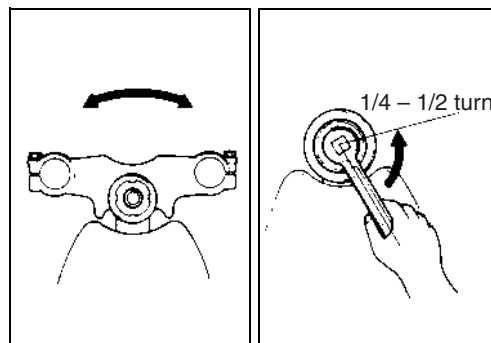

**HANDLEBAR HOLDER AND FRONT FORK AND STEERING STEM UPPER BRACKET**

- Install the handlebar holder ① and handlebar holder bracket ②.
- Temporarily tighten the handlebar holder bolts and handlebar holder bracket bolts.

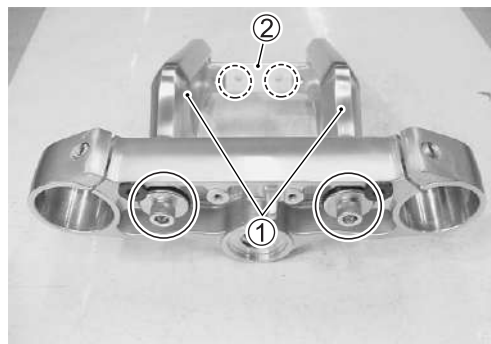

- Install the steering stem upper bracket, washer and steering stem head nut.
- Install the front forks to the steering stem and tighten the front fork lower clamp bolts temporarily.
- Install the headlight cover brace and headlight back cover. (☞ 11-50)
- Install the handlebar. (☞ 9-31)
- Tighten the steering stem head nut ③ to the specified torque.

 **Steering stem head nut: 90 N·m (9.0 kgf·m, 65.0 lb-ft)**

- Remount the front forks. (☞ 9-22)
- Remove the handlebar.

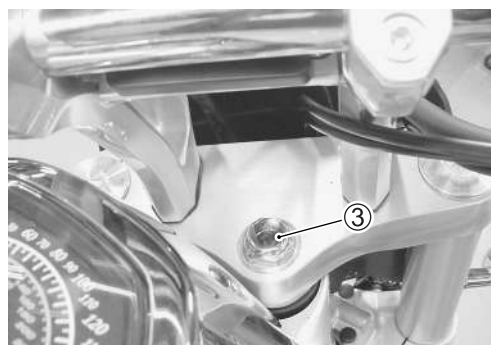



Tighten the following points:

- Tighten the handlebar bracket bolts to the specified torque.

 **Handlebar holder bracket bolt:**

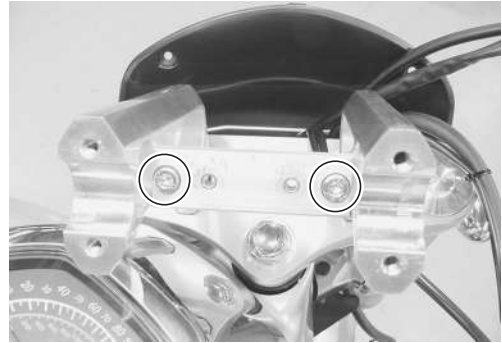
**23 N·m (2.3 kgf-m, 16.5 lb-ft)**



- Install the tachometer. ( 10-32)

- Install the handlebar. ( 9-31)

 **Handlebar clamp bolt: 23 N·m (2.3 kgf-m, 16.5 lb-ft)**

- Tighten the handlebar holder bolts to the specified torque.

 **Handlebar holder bolt: 85 N·m (8.5 kgf-m, 61.5 lb-ft)**



**NOTE:**

Check the handlebar switch lead wires, throttle cables and brake hoses, before installing the front forks. ( 11-35, -38 to -39)

- Install the front wheel. ( 9-13)

## STEERING TENSION ADJUSTMENT

Check the steering movement in the following procedure.

- By supporting the motorcycle with a jack, lift the front wheel until it is off the floor by 20 – 30 mm (0.8 – 1.2 in).
- Check to make sure that the cables and wire harnesses are properly routed.
- With the front wheel in the straight ahead state, hitch the spring scale (special tool) on one handlebar grip end as shown in the figure and read the graduation when the handlebar starts moving. Do the same on the other grip end.

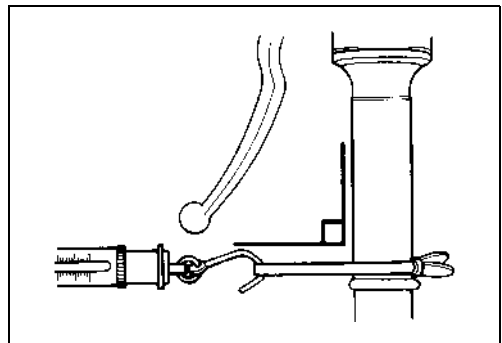

 **Initial force: 200 – 500 grams**

 **09940-92720: Spring scale**

- If the initial force read on the scale when the handlebar starts turning is either too heavy or too light, adjust it till it satisfies the specification.

- 1) First, loosen the front fork upper clamp bolts, steering stem head nut and steering stem lock-nut, and then adjust the steering stem nut by loosening or tightening it.
- 2) Tighten the steering stem lock-nut, stem head nut and front fork upper clamp bolts to the specified torque and re-check the initial force with the spring scale according to the previously described procedure.
- 3) If the initial force is found within the specified range, adjustment has been completed.

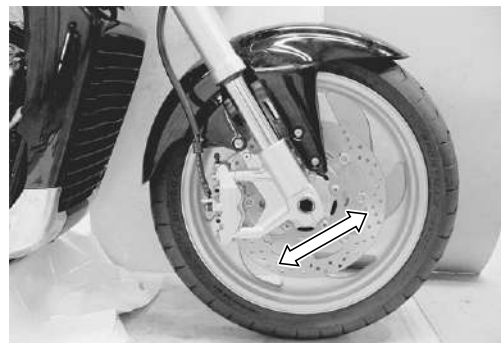

**NOTE:**

Hold the front fork legs, move them back and forth and make sure that the steering is not loose.

## HANDLEBARS CONSTRUCTION

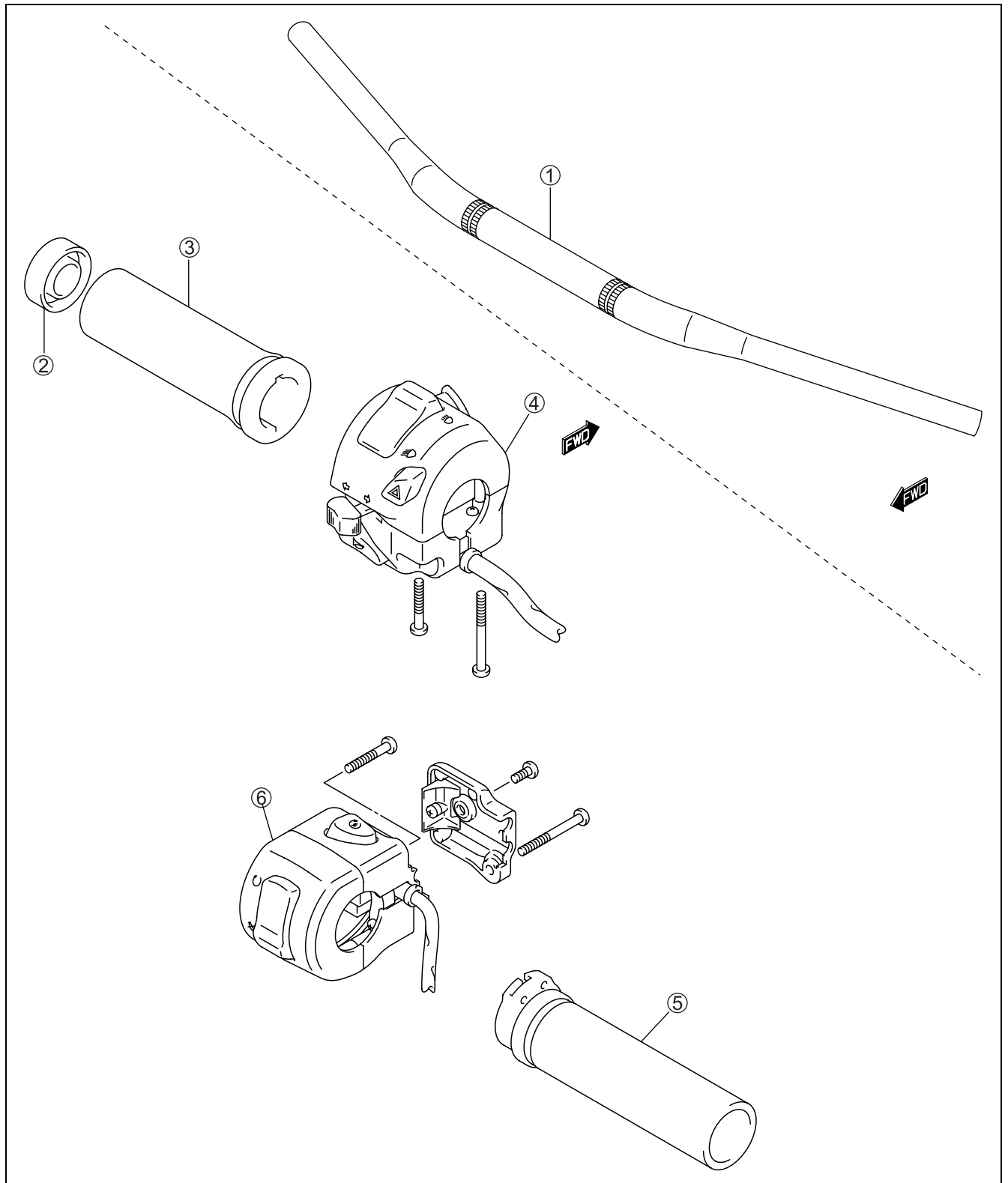

①	Handlebars	③	Left handlebar grip	⑤	Right handlebar grip
②	Grip end cap	④	Left handlebar switch	⑥	Right handlebar switch

## REMOVAL

- Remove the right rear view mirror ①.
- Remove the brake master cylinder ②.
- Remove the throttle grip end cap ③.
- Disconnect the front brake switch lead wire coupler ④ and remove the right handlebar switch ⑤.
- Disconnect the throttle cable by removing the throttle grip ⑥.

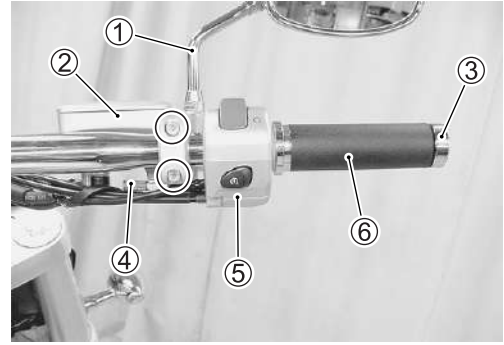

- Remove the left handlebar switch ⑦ and disconnect the clutch lever switch lead wire coupler ⑧.
- Remove the left handlebar grip end cap ⑨ and left handlebar grip ⑩.
- Remove the left rear view mirror ⑪ and loosen the clutch lever holder bolt ⑫.

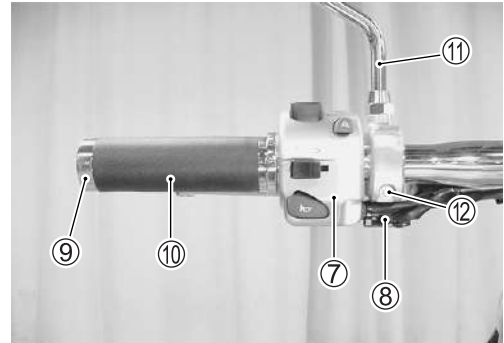

- Remove the handlebar clamp bolt caps ⑬.

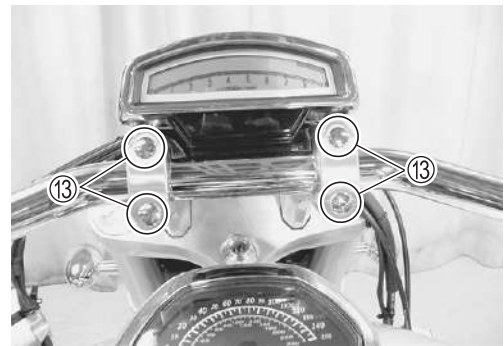

- Remove the handlebar clamp bolts ⑭.
- Remove the handlebar with the clutch lever holder.



## INSTALLATION

Install the handlebar in the reverse order of removal. Pay attention to the following points:

- When setting the handlebar clamp to the handlebar holder, face the punched mark **(A)** to the forward.

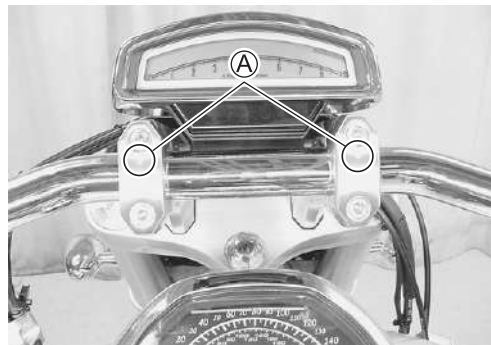

- Align the punched mark **(B)** on handlebars with the handlebar clamp mating surface as shown.

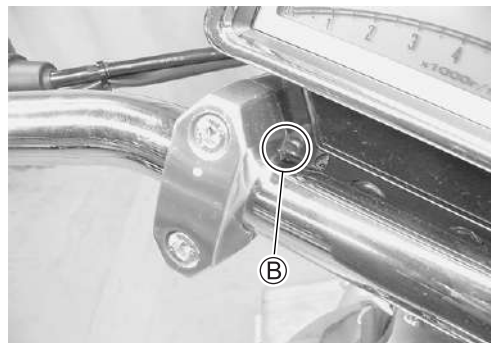

- First, tighten the handlebar clamp bolts **(1)** to the half of specified torque, and then tighten the handlebar clamp bolts **(1)** and **(2)** to the specified torque.

**🔧 Handlebar clamp bolt: 23 N·m (2.3 kgf·m, 16.5 lb-ft)**

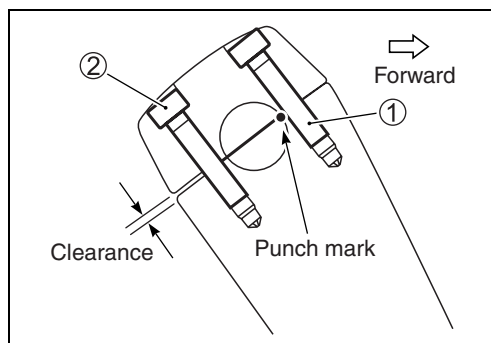

- Install the clutch lever holder, align the holder's mating surface **(C)** with punched mark **(D)** on the handlebars.

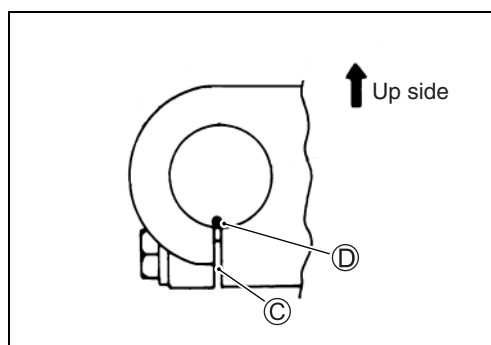

- Apply a handle grip bond onto the left handlebars before installing the handlebar grip.

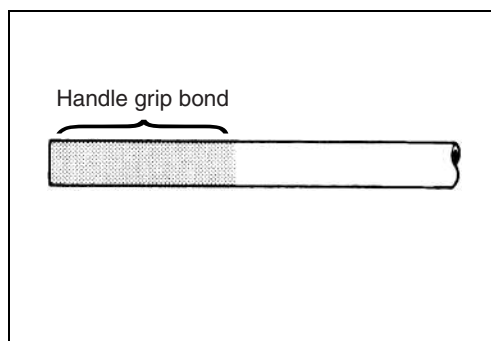



- Install the front brake master cylinder. (☞ 9-61)
- Apply the SUZUKI SUPER GREASE “A” to the throttle cables and their holder.

 **99000-25010: SUZUKI SUPER GREASE “A”  
or equivalent**

- When remounting the right and left handlebar switches, engage the stopper with the handlebar hole.

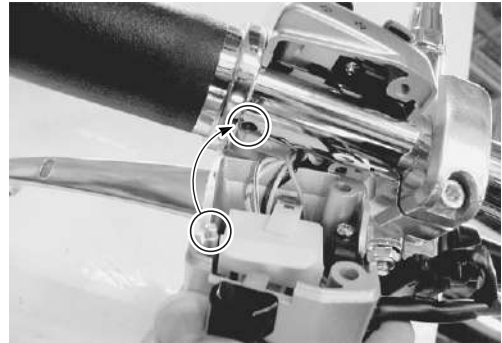
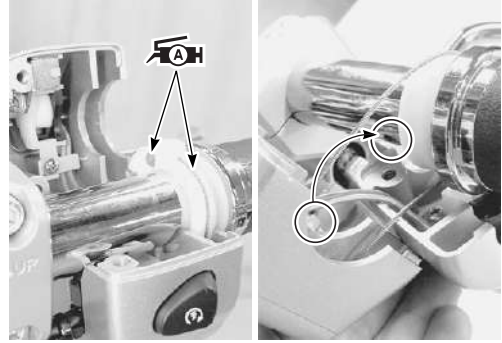

After installing the handlebars, the following adjustments are required before driving.

- Cable routing (☞ 11-36 and -38)
- Throttle cable play (☞ 2-19)

# REAR WHEEL CONSTRUCTION

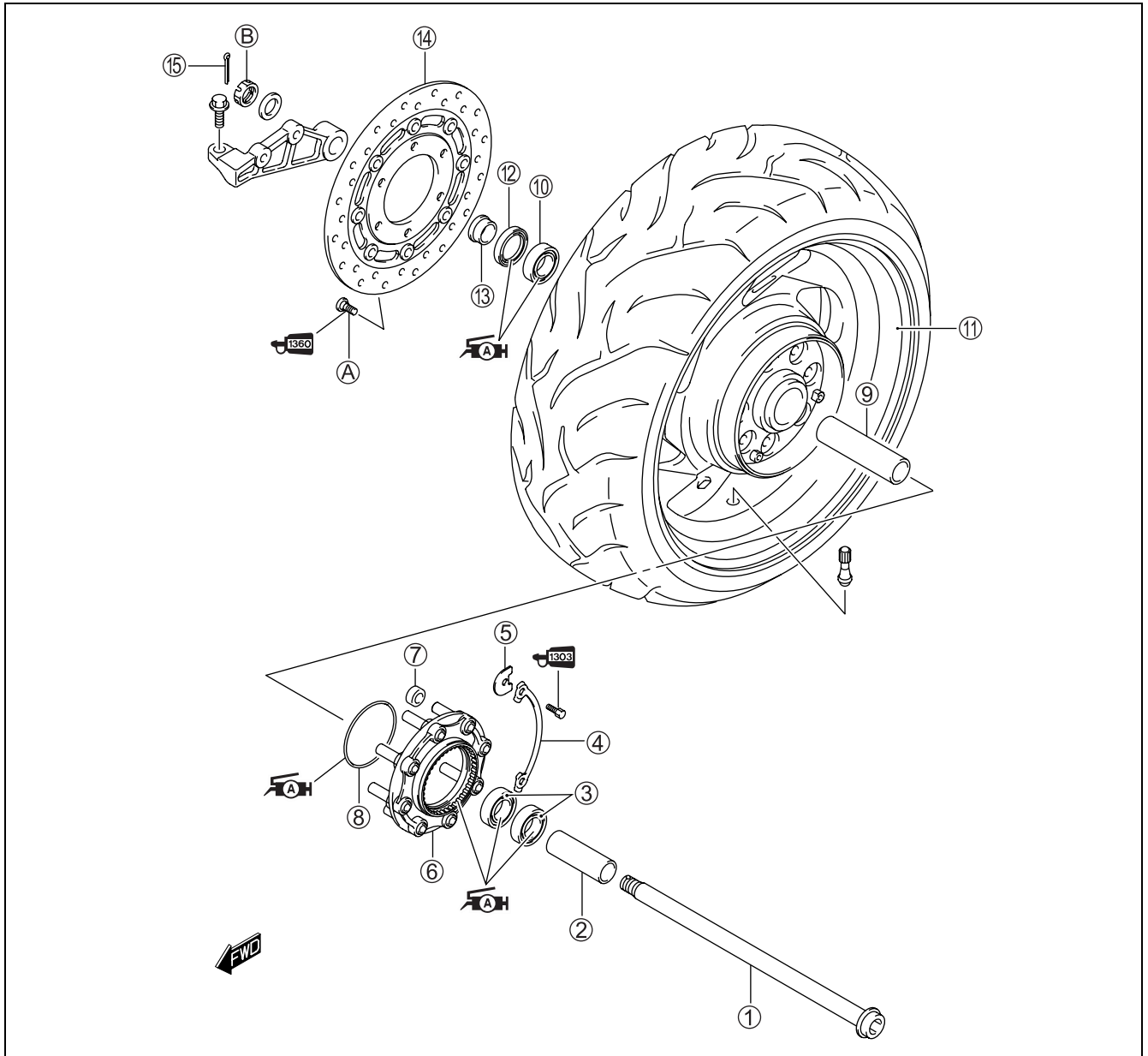

①	Rear axle	⑦	Damper	⑬	Collar
②	Spacer	⑧	O-ring	⑭	Brake disc
③	Bearing	⑨	Spacer	⑮	Cotter pin (For E-03, 28, 33)
④	Lock washer	⑩	Bearing	Ⓐ	Rear brake disc bolt
⑤	Driven joint stopper	⑪	Rear wheel	Ⓑ	Rear axle nut
⑥	Driven joint	⑫	Dust seal		



ITEM		N·m	kgf·m	lb·ft
Ⓐ		23	2.3	16.5
Ⓑ	(For E-03, 28, 33)	100	10.0	72.5
	(For others)	110	11.0	79.5

## REMOVAL

- Remove the brake caliper bracket mounting bolt ①.
- Remove the cotter pin ②. (For E-03, 28, 33)
- Hold the rear axle with the special tool and remove the axle nut ③.

 **09944-28320: Hexagon socket**

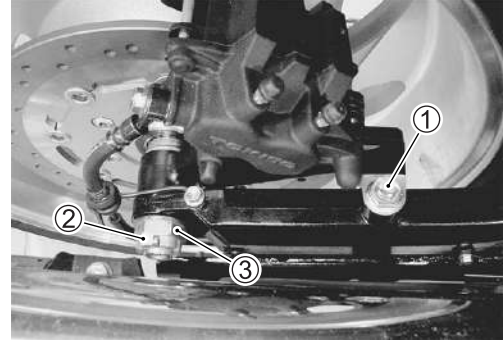

- Raise the rear wheel off the ground and support the motorcycle with a jack or wooden block.
- Draw out the rear axle and collar ④.
- Remove the rear wheel.

### CAUTION

**Do not operate the brake pedal while removing the caliper.**

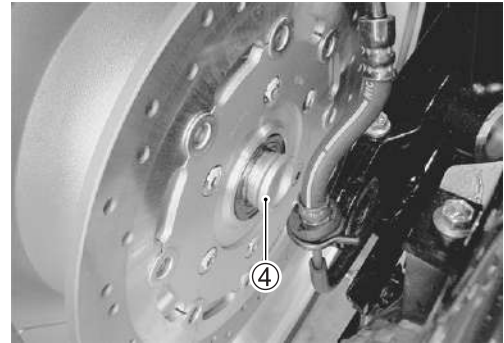

## DISASSEMBLY

- Flatten the lock washers.
- Remove the bolts, washers and plates.



- Remove the driven hub joint ① with the special tool and wooden block.

 **09913-50121: Oil seal remover**

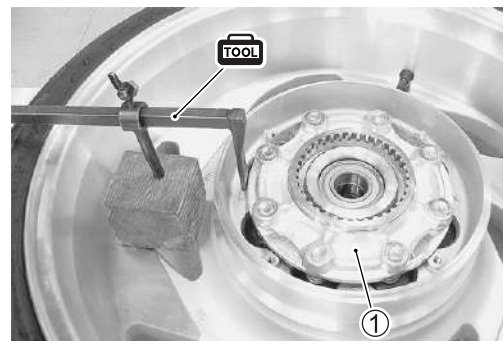

- Remove the O-ring ②.



## INSPECTION AND DISASSEMBLY

### WHEEL DAMPER

- Inspect the damper for wear or damage.
- Replace the damper if there is anything unusual.
- Remove the dampers with a screw driver.



### WHEEL (👉 9-73)

### WHEEL AXLE (👉 9-9)

### TIRE (👉 2-27 and 9-73)

### BRAKE DISC (👉 9-69)

- Remove the brake disc ①.

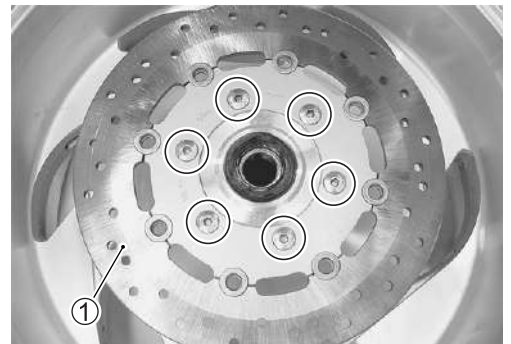

### WHEEL BEARINGS

- Inspect the play of the wheel bearings by finger while they are in the wheel. Rotate the inner race by finger to inspect for abnormal noise and smooth rotation.
- Replace the bearing in the following procedure if there is anything unusual.

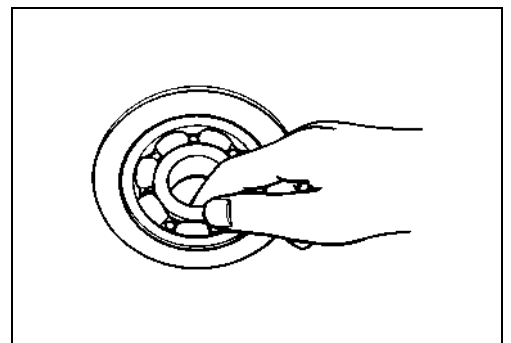

- Remove the dust seal with the special tool.

**TOOL** 09913-50121: Oil seal remover

### CAUTION

The removed dust seal must be replaced with a new one.



- Remove the wheel bearings on both sides with the special tool.

**TOOL** 09921-20240: Bearing remover set (25 mm)

**CAUTION**

The removed bearings should be replaced with new ones.

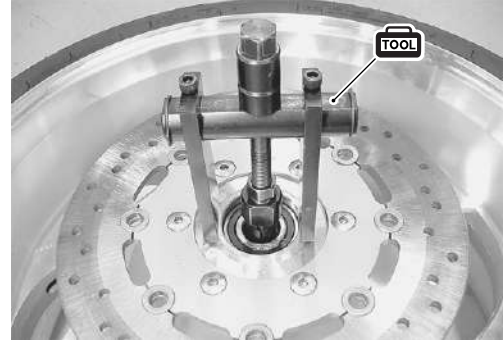

## REASSEMBLY AND INSTALLATION

Reassemble and install the rear wheel in the reverse order of removal and disassembly. Pay attention to the following points:

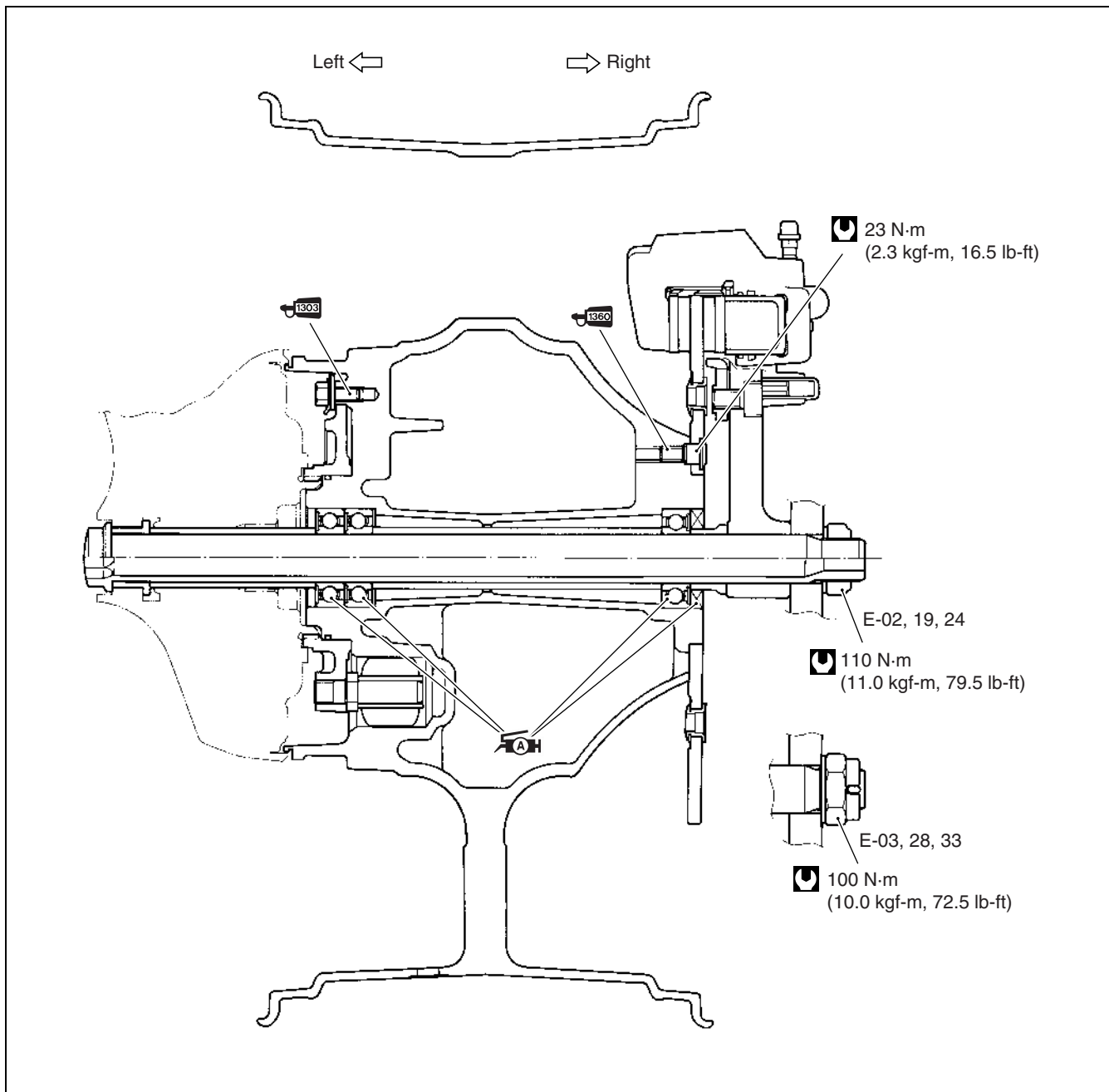

**WHEEL BEARING**

- Apply SUZUKI SUPER GREASE “A” to the wheel bearings.

 99000-25010: SUZUKI SUPER GREASE “A”  
or equivalent

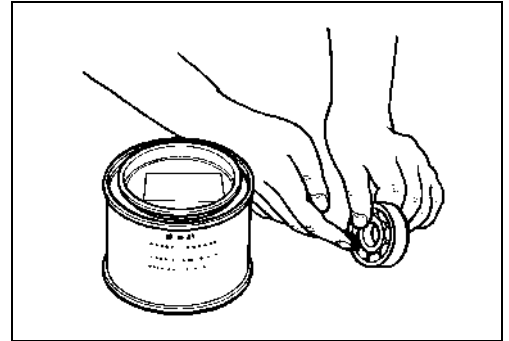

- Install the wheel bearings with the special tools as follows.

 09941-34513: Bearing/Steering race installer set  
09924-84510: Bearing installer set

**CAUTION**

First install the right wheel bearing, then install the spacer and left wheel bearings.  
The sealed cover of the bearing must face outside.

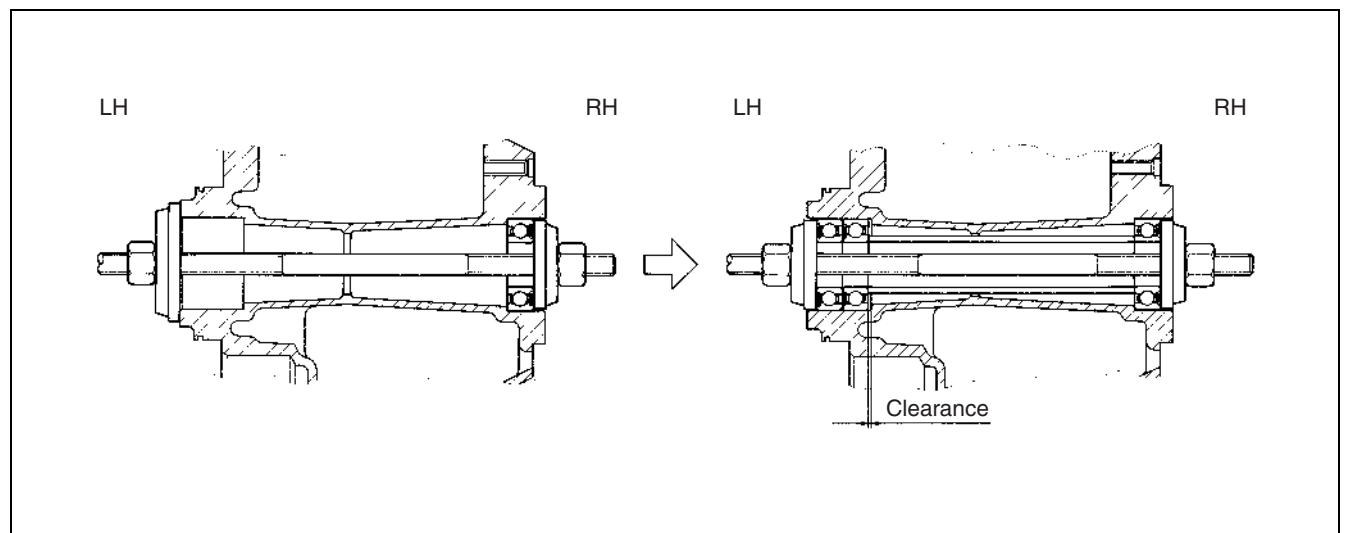

- Install the dust seal with the special tool.

 09913-70210: Bearing installer set (52 mm)

- Apply SUZUKI SUPER GREASE “A” to the dust seal lip.

 99000-25010: SUZUKI SUPER GREASE “A”  
or equivalent





### BRAKE DISC

- Make sure that the brake disc is clean and free of any greasy matter.
- Apply THREAD LOCK SUPER to the disc mounting bolts and tighten them to the specified torque.

 Brake disc bolt: 23 N·m (2.3 kgf-m, 16.5 lb-ft)

 99000-32130: THREAD LOCK SUPER “1360”  
or equivalent

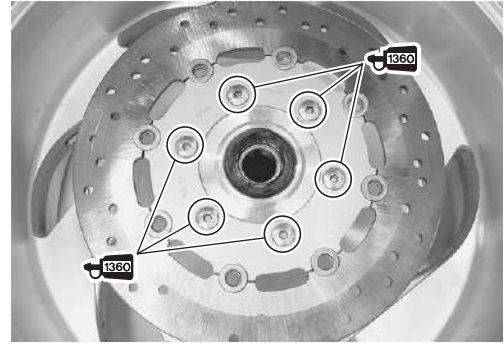

### WHEEL DAMPER

- Install the dampers.

**NOTE:**

*If soap water is applied around the damper, it makes the job easier.*



### DRIVEN HUB JOINT

- Install the new O-ring ① and driven hub joint ②.

**NOTE:**

\* Apply SUZUKI SUPER GREASE “A” to the O-ring and the final gear spline before installing the driven joint.

\* Align the driven joint flat surface (A) with the screw holes (B) of wheel.

 99000-25010: SUZUKI SUPER GREASE “A”  
or equivalent

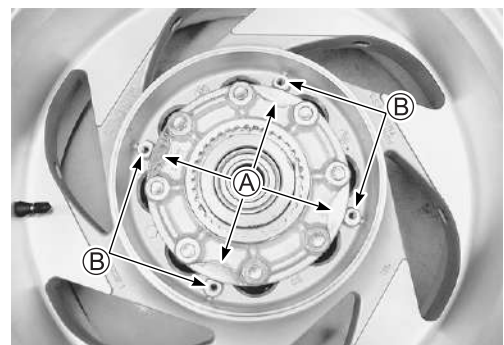
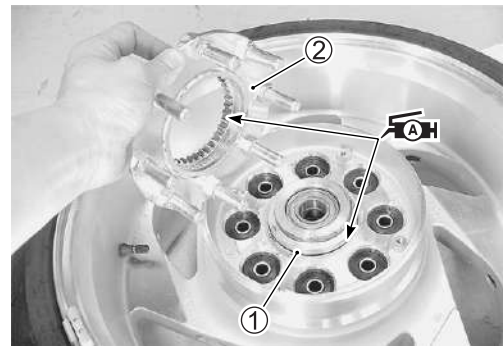

- Apply THREAD LOCK SUPER to the thread of driven hub joint bolts.

 99000-32030: THREAD LOCK SUPER “1303”  
or equivalent

- Tighten the driven hub joint bolts securely.
- Bend up the washer to lock the bolts.

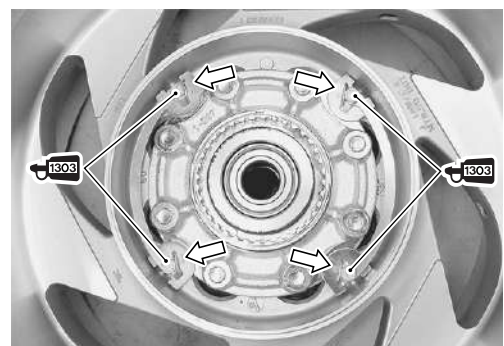

**REAR WHEEL**

- Install the spacer ①.
- Apply SUZUKI SUPER GREASE “A” to the final gear spline before installing the rear wheel.

 **99000-25010: SUZUKI SUPER GREASE “A”**  
or equivalent

- Remount the rear wheel, rear axle and collar.
- Install the washer and rear axle nut.
- Install the brake caliper with the caliper bracket.
- Tighten the rear axle nut ① to the specified torque with the special tool.

 **09944-28320: Hexagon socket**

 **Rear axle nut**  
(For E-03, 28, 33): 100 N·m (10.0 kgf-m, 72.5 lb-ft)  
(For others): 110 N·m (11.0 kgf-m, 79.5 lb-ft)

- Tighten the brake caliper bracket mounting bolt ② to the specified torque.

 **Brake caliper bracket mounting bolt:**  
80 N·m (8.0 kgf-m, 58.0 lb-ft)

**NOTE:**

*After remounting the rear wheel, check for proper brake operation.*

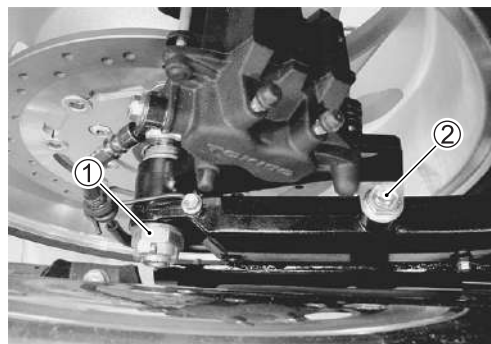
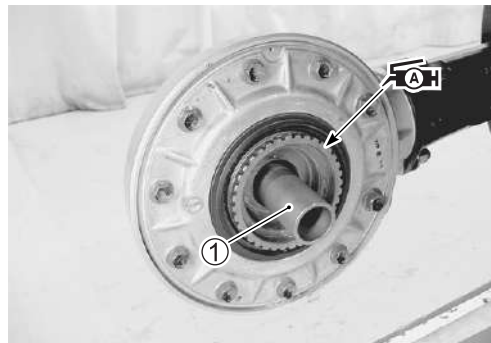

# REAR SUSPENSION CONSTRUCTION

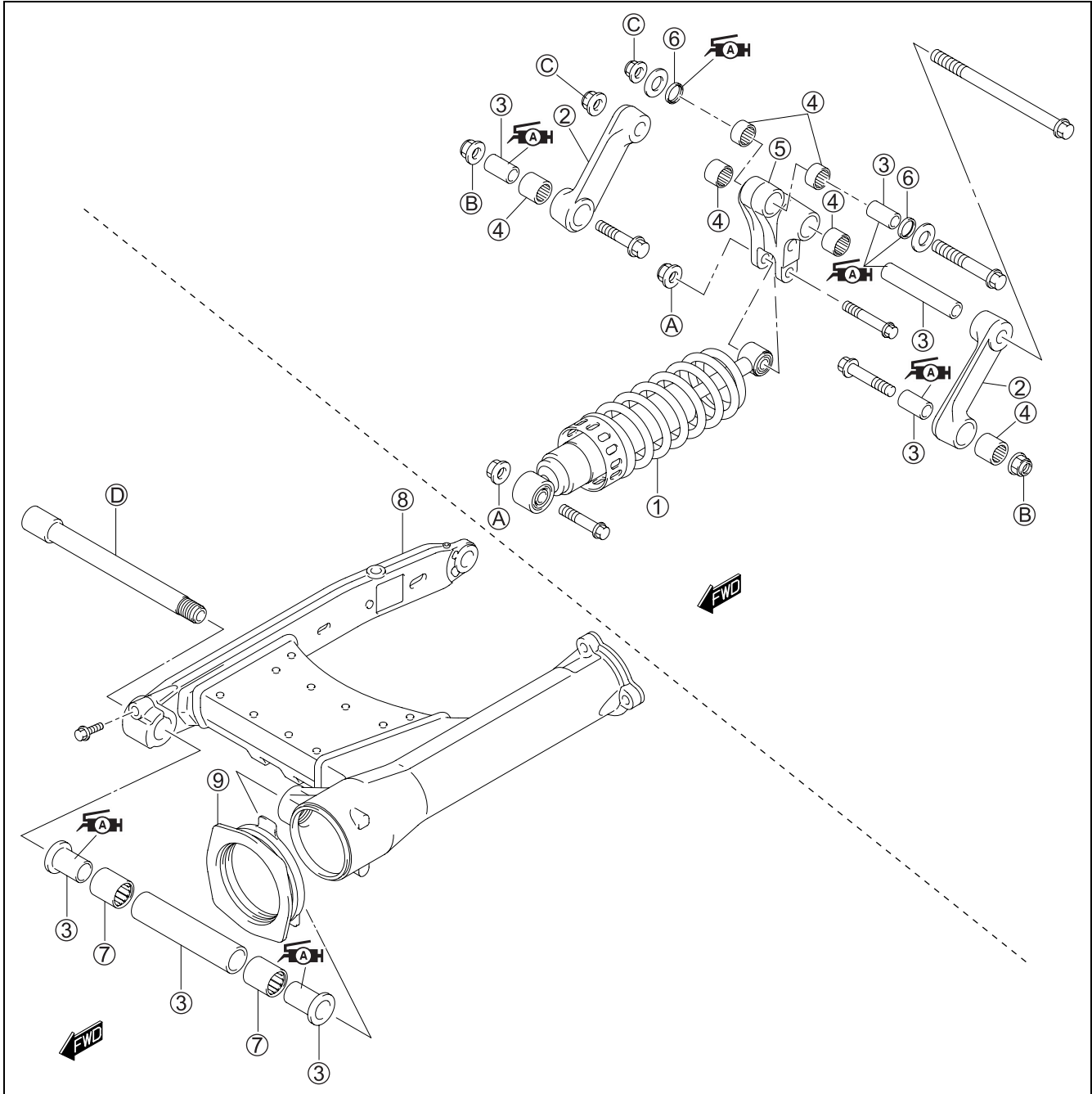

①	Rear shock absorber	⑥	Dust seal	⑧	Rear cushion rod mounting nut
②	Rear cushion rod	⑦	Swingarm pivot bearing	⑨	Rear cushion lever mounting nut
③	Spacer	⑧	Swingarm	⑩	Swingarm pivot shaft
④	Rear cushion lever bearing	⑨	Boot		
⑤	Rear cushion lever	⑩	Rear shock absorber mounting nut		



ITEM	N·m	kgf·m	lb·ft
①	45	4.5	32.5
②	85	8.5	61.5

ITEM	N·m	kgf·m	lb·ft
③	110	11.0	79.5
④	100	10.0	72.5

## REMOVAL

- Remove the exhaust pipe and muffler. (☞ 7-8)
- Remove the rear wheel. (☞ 9-34)
- Remove the final gear case. (☞ 4-15)
- Remove the under plate ①.

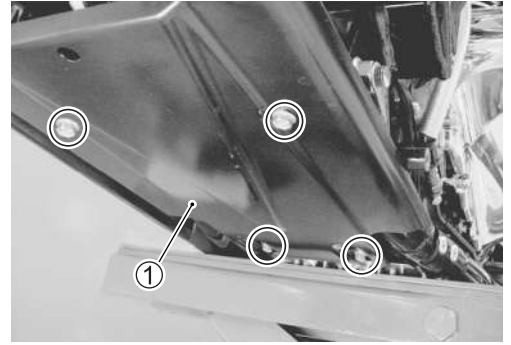

- Remove the regulator/rectifier ②.

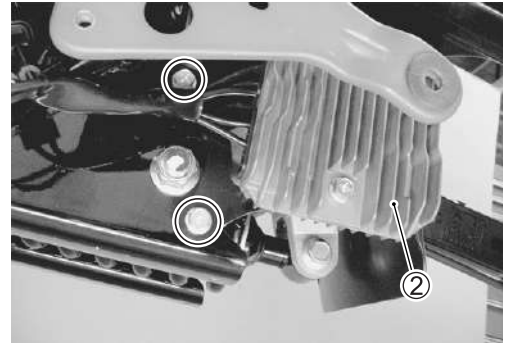

- Remove the rear shock absorber front mounting bolt and nut.



- Remove the rear shock absorber rear mounting bolt and nut.
- Remove the rear shock absorber ③.
- Remove the cushion rod mounting bolt and nut ④.

### NOTE:

*Slightly loosen the cushion lever mounting bolt or nut (A) to facilitate later disassembly.*

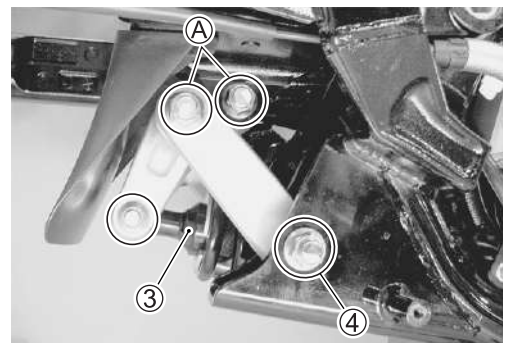

- Remove the brake pipe guide bolts.





- Loosen the swingarm pivot pinch bolt ⑤.
- Loosen the swingarm pivot shaft with the special tool.

**TOOL** 09944-28320: Hexagon socket

- Draw out the swingarm pivot shaft.
- Remove the rear suspension assembly.

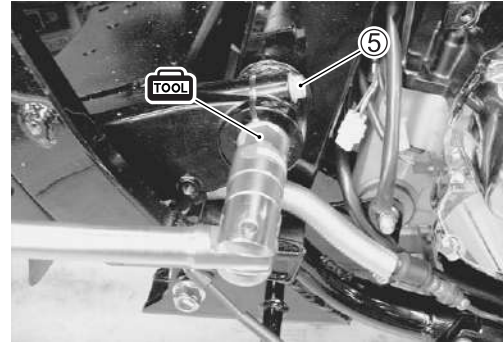

- Remove the cushion rods ⑥ and cushion lever ⑦.
- Remove the rear fender ⑧.

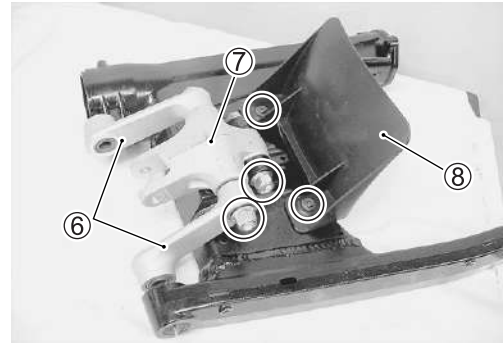

## INSPECTION AND DISASSEMBLY SPACER

- Remove the spacers from frame.
- Remove the spacers from the cushion lever.
- Remove the spacers from the cushion rod.
- Inspect the spacers for any flaws or other damage. If any defects are found, replace the spacers with new ones.

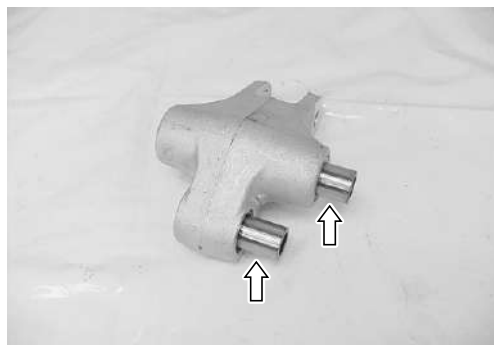
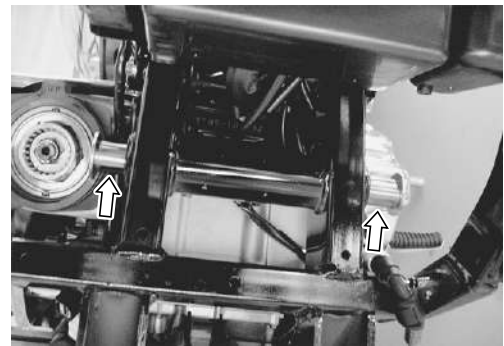

## FRAME BEARING

- Insert the spacer into bearing and check the play when moving the spacer up and down.
- If excessive play is noted, replace the bearing with a new one.



- Remove the swingarm pivot bearings ① with the special tools.

**TOOL** 09923-74511: Bearing remover set  
09930-30104: Sliding shaft

#### CAUTION

The removed bearings must be replaced with new ones.

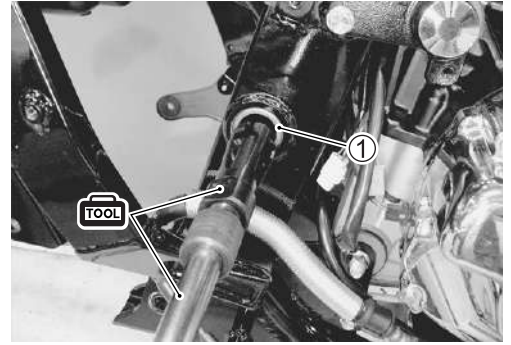

#### CUSHION LEVER BEARING

- Insert the spacer into bearings and check the play when moving the spacer up and down.
- If excessive play is noted, replace the bearings with a new one.

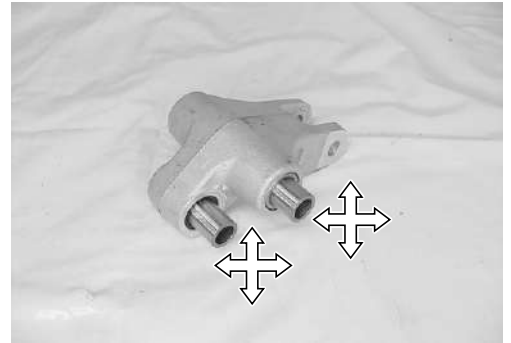

- Remove the dust seals ①.

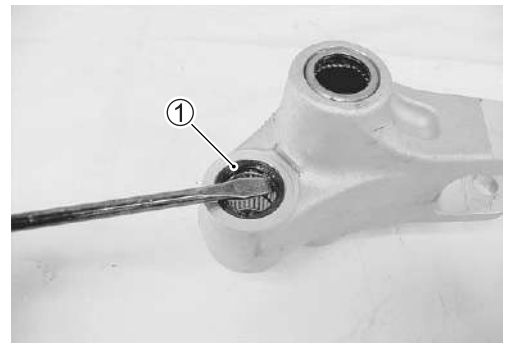

- Remove the cushion lever upper bearings with the special tool.

**TOOL** 09913-70210: Bearing installer set (25 mm)

#### CAUTION

The removed bearings must be replaced with new ones.



- Draw out the cushion lever lower bearings with the special tool.

**TOOL** 09921-20240: Bearing remover set (20 mm)

#### CAUTION

The removed bearings must be replaced with new ones.





### CUSHION ROD BEARING

- Insert the spacer into bearings and check the play when moving the spacer up and down.
- If excessive play is noted, replace the bearings with a new one.

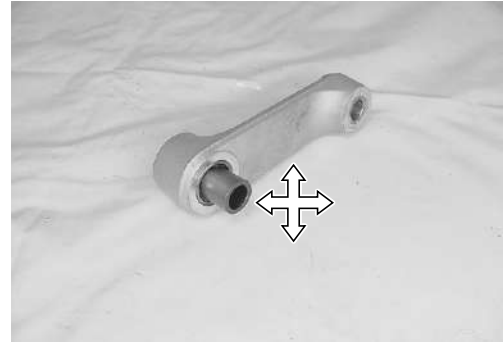

- Remove the cushion lever bearings ① with the special tool.

**TOOL** 09913-70210: Bearing installer set (25 mm)

#### CAUTION

The removed bearings must be replaced with new ones.

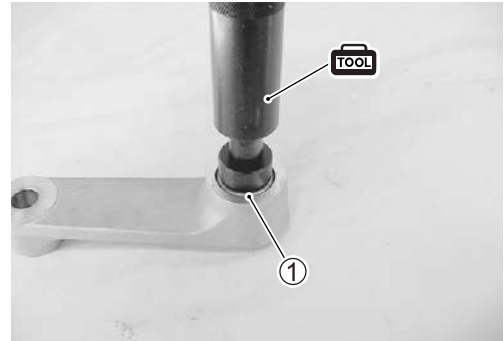

### CUSHION LEVER AND CUSHION LEVER RODS

- Inspect the cushion lever and cushion lever rods for damage. If any defects are found, replace it with a new one.



### SWINGARM

- Inspect the swingarm for damage. If any defects are found, replace the swingarm with a new one.



### SHOCK ABSORBER

- Inspect the shock absorber body and bush for damage and oil leakage. If any defects are found, replace the shock absorber with a new one.

#### CAUTION

Do not attempt to disassemble the rear shock absorber unit. It is unserviceable.



### SWINGARM PIVOT SHAFT

- Using a dial gauge, check the pivot shaft runout and replace it if the runout exceeds the limit.

**DATA** Swingarm pivot shaft runout:  
Service limit: 0.3 mm (0.01 in)

**TOOL** 09900-20607: Dial gauge (1/100 mm, 10 mm)  
09900-20701: Magnetic stand  
09900-21304: V-block set (100 mm)

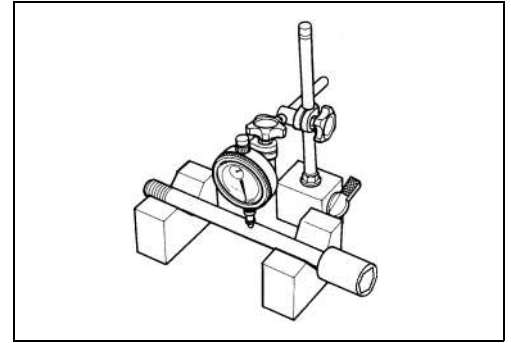

### REAR SHOCK ABSORBER DISPOSAL

#### ⚠ WARNING

- \* The rear shock absorber unit contains high-pressure nitrogen gas.
- \* Mishandling can cause explosion.
- \* Keep away from fire and heat. High gas pressure caused by heat can cause an explosion.
- \* Release gas pressure before disposing.

### GAS PRESSURE RELEASE

#### ⚠ WARNING

- \* Never apply heat or disassemble the damper unit since it can explode or oil can splash hazardously.
- \* When discarding the rear cushion unit, be sure to release gas pressure from the unit following the procedures below.

- Mark the drill center at the location using a center punch.
- Wrap the rear cushion unit with a vinyl bag and fix it on a vise as shown.
- Drill a 2 – 3 mm (0.08 – 0.12 in) hole at the marked drill center using a drilling machine and let out gas while taking care not to get the vinyl bag entangled with the drill bit.

#### ⚠ WARNING

- \* Be sure to wear protective glasses since drilling chips and oil may fly off with blowing gas when the drill bit has penetrated through the body.
- \* Make sure to drill at the specified position. Otherwise, pressurized oil may spout out forcefully.

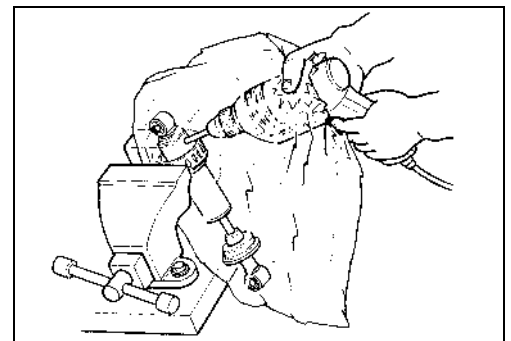
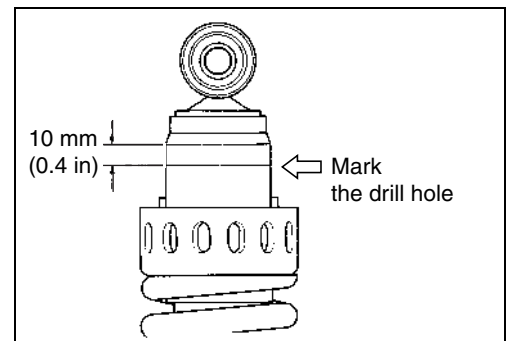

## REASSEMBLY

Reassemble the rear suspension in the reverse order of disassembly and removal.  
Pay attention to the following points:

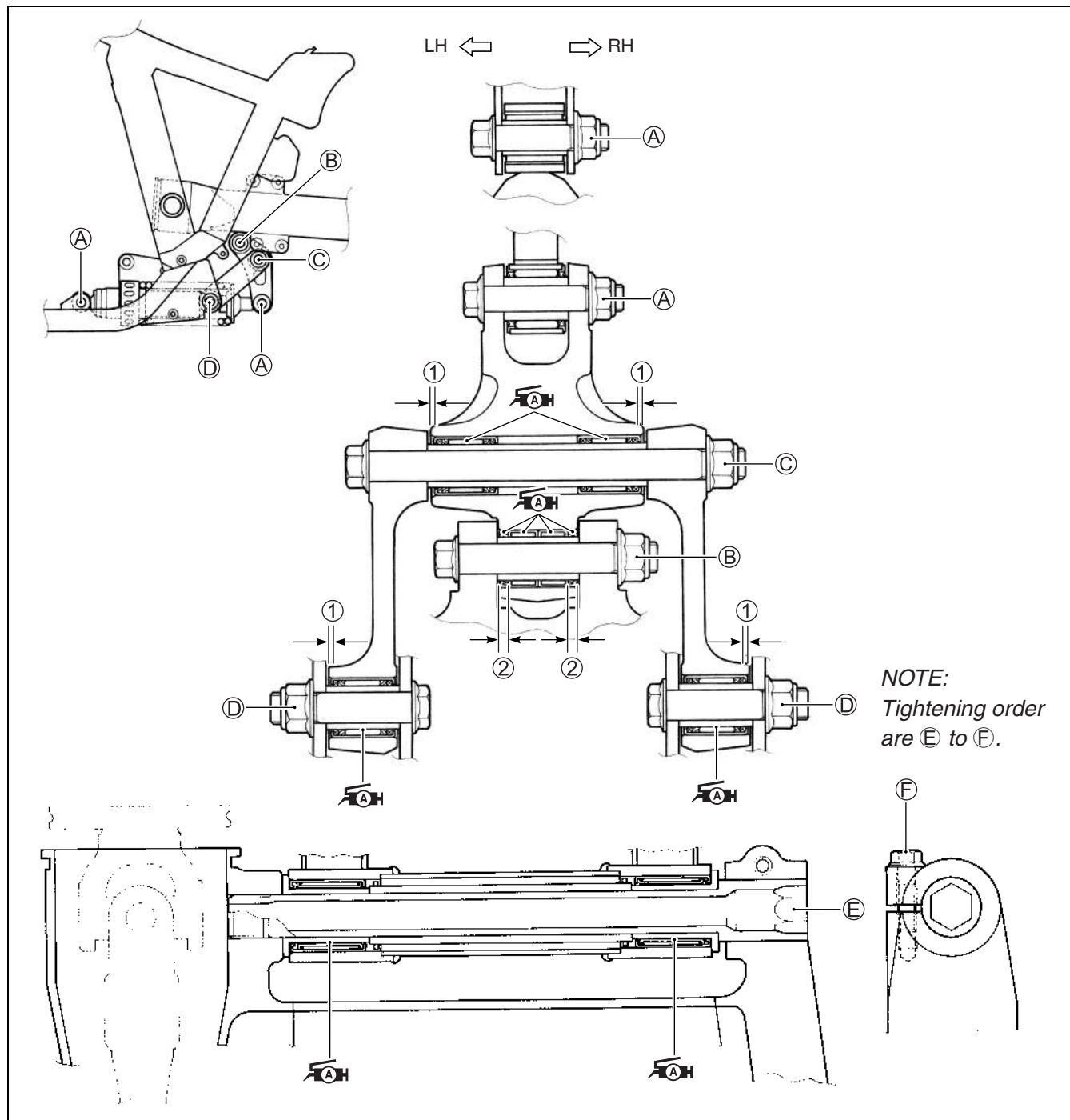

①	1.0 mm (0.04 in)	Ⓒ	Rear cushion lever lower nut
②	4.5 mm (0.17 in)	Ⓓ	Rear cushion rod nut
Ⓐ	Rear shock absorber nut	Ⓔ	Swingarm pivot shaft
Ⓑ	Rear cushion lever upper nut	Ⓕ	Swingarm pivot shaft clamp bolt



ITEM	N-m	kgf-m	lb-ft
Ⓐ	45	4.5	32.5
Ⓑ	110	11.0	79.5
Ⓒ	85	8.5	61.5
Ⓓ	110	11.0	79.5
Ⓔ	100	10.0	72.5

### CUSHION ROD BEARING

- Install the bearings into the cushion rod with the special tool.

**TOOL 09913-70210: Bearing installer set (35 mm)**

- Press the bearing at 1.0 mm (0.04 in) depth from the cushion rod edge. (🔧 9-46)

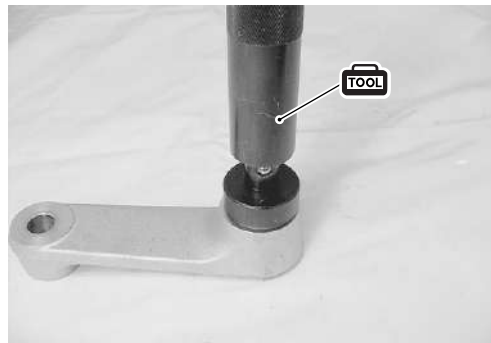

### CUSHION LEVER BEARING

- Press the cushion lever upper bearings into the cushion lever with the special tool and suitable size socket wrench ①.

**TOOL 09924-84521: Bearing installer set**

#### NOTE:

- \* When installing the bearing, stamped mark on the bearing must face outside.
- \* Press the bushing at 4.5 mm (0.17 in) depth from the cushion lever edge. (🔧 9-46)

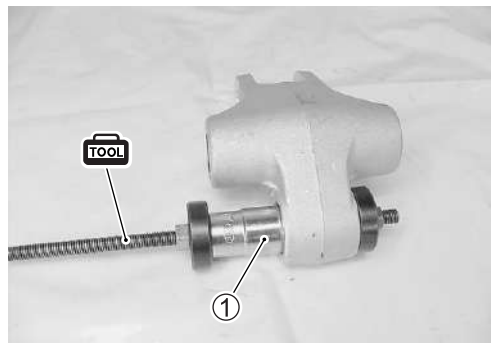

- Press the cushion lever lower bearings with the special tool.

**TOOL 09924-84521: Bearing installer set**

#### NOTE:

- \* When installing the bearing, stamped mark on the bearing must face outside.
- \* Press the bushing at 1.0 mm (0.04 in) depth from the cushion lever edge. (🔧 9-46)



- Install the dust seals into the cushion lever with the special tool.

**TOOL 09913-70210: Bearing installer set (35 mm)**

#### NOTE:

Apply SUZUKI SUPER GREASE "A" to the dust seals.

**TAH 99000-25010: SUZUKI SUPER GREASE "A"**  
or equivalent

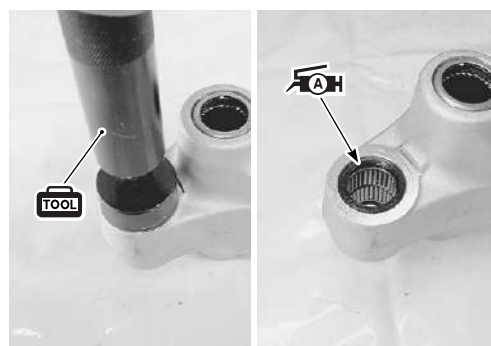

### SWINGARM BEARING

- Press the swingarm pivot bearings into the frame with the special tool.

**TOOL 09941-34513: Steering race installer**

#### NOTE:

When installing the bearing, stamped mark on the bearing must face outside.

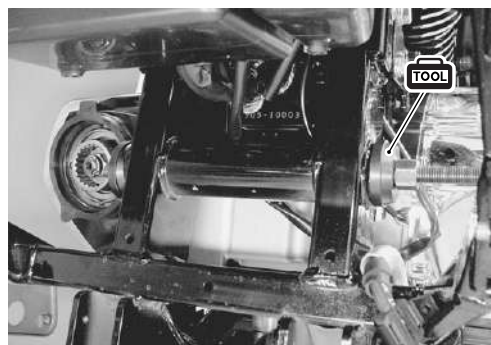

- Apply SUZUKI SUPER GREASE "A" to the spacers.

 99000-25010: SUZUKI SUPER GREASE "A"  
or equivalent

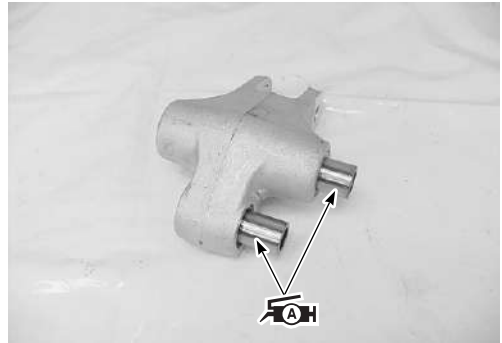

## INSTALLATION

Remount the swingarm and shock absorber in the reverse order of disassembly and removal, and pay attention to the following points.

### CUSHION ROD AND CUSHION LEVER

- Install the cushion rods ① and cushion lever ② onto the swingarm temporarily.

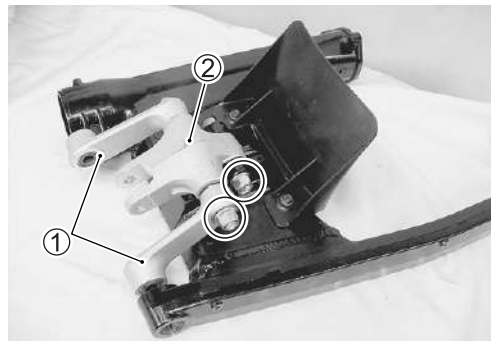

### SWINGARM

- Before installing the swingarm, install the boot and the universal joint.

#### NOTE:

Make sure that the "UP" mark  $\text{\textcircled{A}}$  on the boot faces to up.

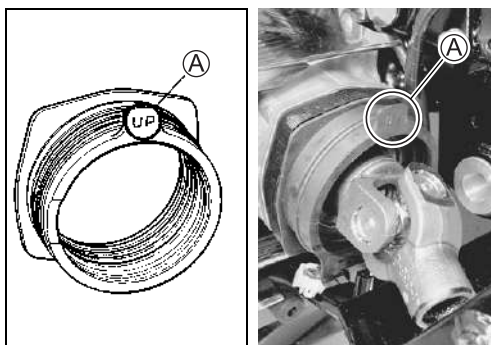

- Tighten the swingarm pivot shaft to the specified torque with the special tool.

 **09944-28320: Hexagon socket**

 **Swingarm pivot shaft: 100 N·m (10.0 kgf·m, 72.5 lb-ft)**



#### NOTE:

After tightening the swingarm pivot shaft, be sure to check the swingarm operation.

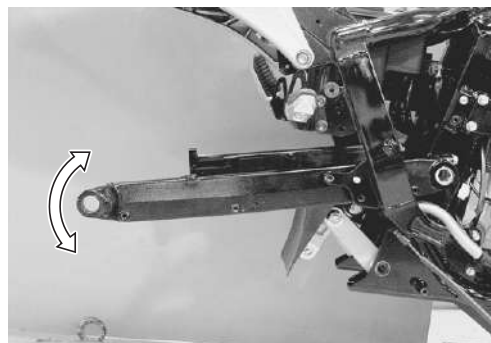



- Tighten the swingarm pivot pinch bolt.



### CUSHION ROD, CUSHION LEVER AND REAR SHOCK ABSORBER

- Assemble the cushion rod, cushion lever and rear shock absorber onto the swingarm. (☞ 9-46)
- Tighten the rear shock absorber front mounting nut to the specified torque.

 **Rear shock absorber mounting nut:**  
45 N·m (4.5 kgf-m, 32.5 lb-ft)



- Tighten the cushion rod nut ① to the specified torque.

 **Cushion rod mounting nut:**  
110 N·m (11.0 kgf-m, 79.5 lb-ft)

- Tighten the cushion lever mounting nuts ② and ③ to the specified torque.

 **Cushion lever mounting nut**  
②: 110 N·m (11.0 kgf-m, 79.5 lb-ft)  
③: 85 N·m (8.5 kgf-m, 61.5 lb-ft)

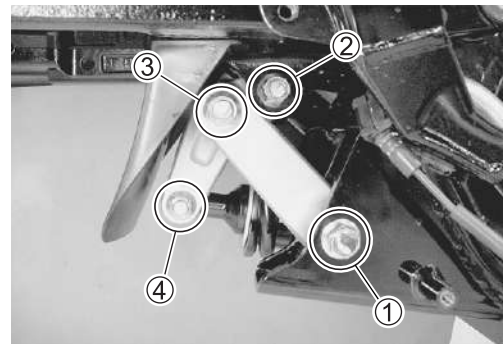

- Tighten the rear shock absorber rear mounting nut ④ to the specified torque.

 **Rear shock absorber mounting nut:**  
45 N·m (4.5 kgf-m, 32.5 lb-ft)

- Install the final gear case. (☞ 4-28)
- Install the rear wheel. (☞ 9-39)
- Install the exhaust pipes and mufflers. (☞ 7-10)

### SUSPENSION SETTING

After installing the rear suspension, adjust the spring pre-load as follows.

Spring pre-load adjuster (STD)	4th
--------------------------------	-----



# FRONT BRAKE CONSTRUCTION

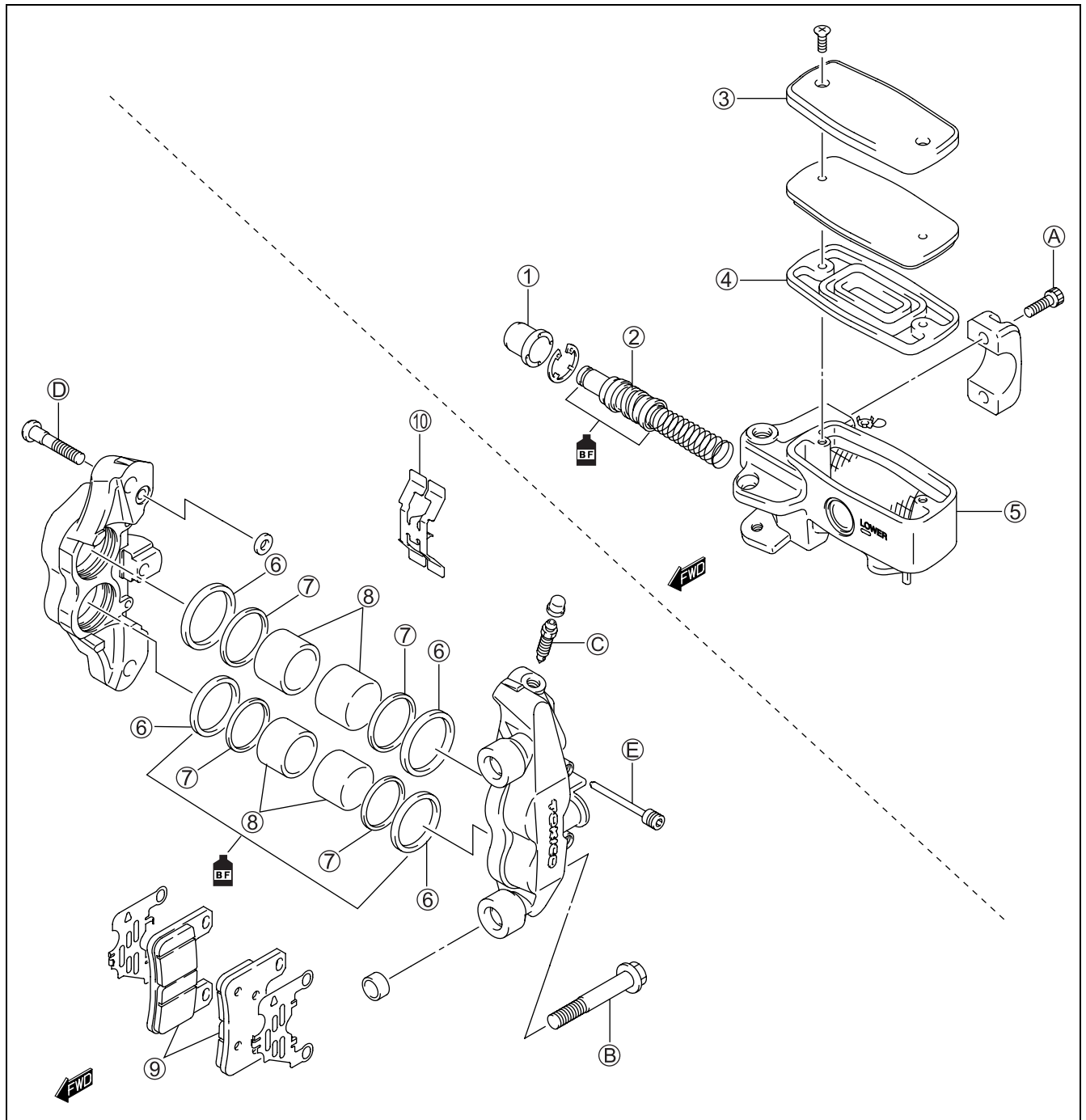

①	Dust boot	⑨	Brake pad
②	Piston set	⑩	Brake pad spring
③	Cap	(A)	Master cylinder mounting bolt
④	Diaphragm	(B)	Brake caliper mounting bolt
⑤	Master cylinder	(C)	Brake caliper air bleeder valve
⑥	Piston seal	(D)	Brake caliper housing bolt
⑦	Dust seal	(E)	Brake pad mounting pin
⑧	Brake caliper piston		



ITEM	N·m	kgf·m	lb·ft
(A)	10	1.0	7.0
(B)	39	3.9	28.0
(C)	7.5	0.75	5.5
(D)	22	2.2	16.0
(E)	15	1.5	11.0

**⚠ WARNING**

- \* This brake system is filled with an ethylene glycol-based DOT 4 brake fluid. Do not use mix different types of fluid such as silicone-based or petroleum-based.
- \* Do not use any brake fluid taken from old, used or unsealed containers. Never reuse brake fluid left over from the last servicing or stored for long periods.
- \* When storing the brake fluid, seal the container completely and keep away from children.
- \* When replenishing brake fluid, take care not to get dust into fluid.
- \* When washing brake components, use fresh brake fluid. Never use cleaning solvent.
- \* A contaminated brake disc or brake pad reduces braking performance. Discard contaminated pads and clean the disc with high quality brake cleaner or neutral detergent.

**CAUTION**

Handle brake fluid with care: The fluid reacts chemically with paint, plastics, rubber materials etc. and will damage them severely.

**BRAKE PAD REPLACEMENT**

- Loosen the pad mounting pins ①.
- Remove the brake caliper by removing the caliper mounting bolts ②.
- Remove the pad mounting pins ①, brake pads.

**CAUTION**

- \* Do not operate the brake lever with the pads removed.
- \* Replace the brake pads as a set, otherwise braking performance will be adversely affected.

**NOTE:**

- \* When the brake caliper is removed, care must be used so as not to cause stress to the brake hose. (Hang the brake caliper on the frame with a string, etc.)
- \* When removing the brake pad, push the piston all the way into the brake caliper.
- Inspect the pad mounting pins and shims for bent or damage. If any defects are found, replace the pad mounting pins with the new ones.

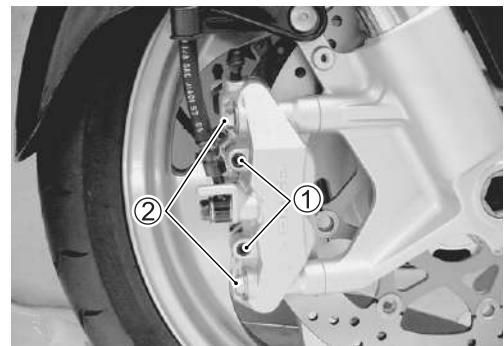

**NOTE:**

- \* Install the brake pad shims ③ onto the new brake pad, as shown.
- \* The arrow mark on the brake shim must face to the direction of brake disc rotation.

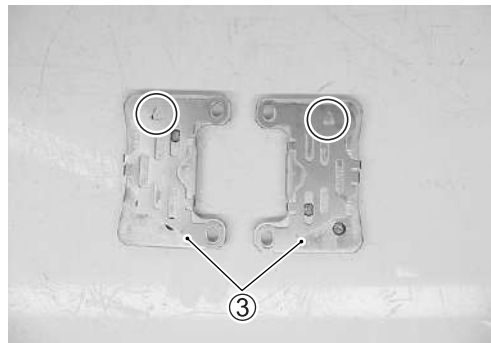

- Install the new brake pads.
- Install the brake caliper.
- Tighten the pad mounting pin ① and front brake caliper mounting bolt ② to the specified torque.

**🔧 Pad mounting pin ①: 15 N·m (1.5 kgf-m, 11.0 lb-ft)**  
**Front brake caliper mounting bolt ②:**  
**39 N·m (3.9 kgf-m, 28.0 lb-ft)**

**NOTE:**

*After replacing the brake pads, pump the brake lever a few times to check for proper brake operation and then check the brake fluid level.*

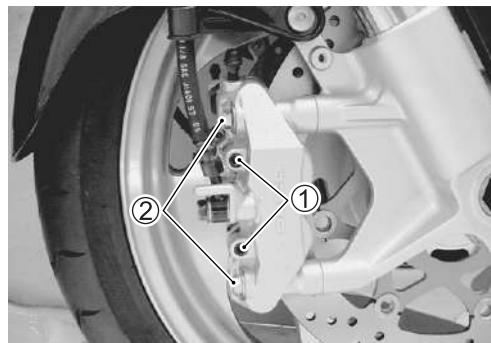
**BRAKE FLUID REPLACEMENT**

- Place the motorcycle on a level surface and keep the handlebars straight.
- Remove the brake fluid reservoir cap ① and diaphragm.
- Drain the old brake fluid as much as possible.
- Fill the reservoir with new brake fluid.

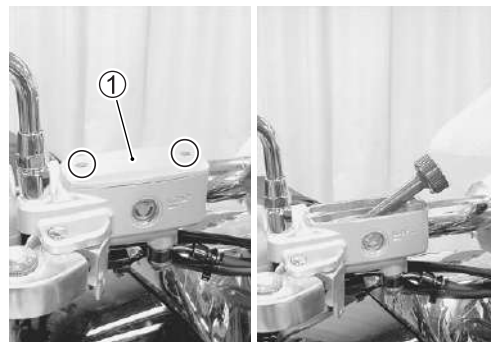

- Connect a clear hose to the caliper air bleeder valve and insert the other end of hose into a receptacle.
- Loosen the air bleeder valve and pump the brake lever until old brake fluid flows out of the bleeder system.
- Close the caliper air bleeder valve and disconnect a clear hose. Fill the reservoir with new fluid to the upper mark of the reservoir.

 **Specification and classification: DOT 4**

### CAUTION

**Bleed air from the brake system. (☞ 2-26)**

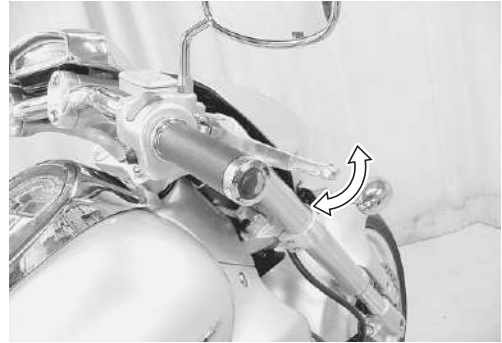
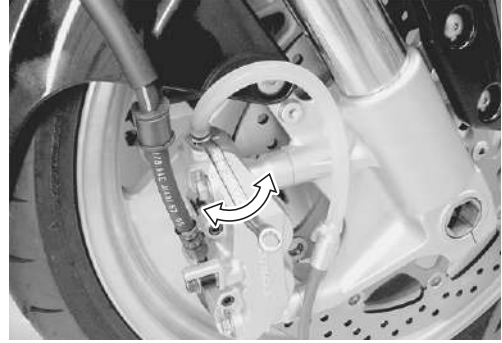

## CALIPER REMOVAL

- Remove the brake hose from the caliper by removing the union bolt ① and catch the brake fluid in a suitable receptacle.

### NOTE:

*Place a rag underneath the union bolt on the brake caliper to catch any split brake fluid.*

- Remove the brake pads. (☞ 9-52)

### CAUTION

**Never reuse the brake fluid left over from previous servicing and stored for long periods of time.**

### ⚠ WARNING

**Brake fluid, if it leaks, will interfere with safe running and discolor painted surfaces. Check the brake hose and hose joints for cracks and fluid leakage.**

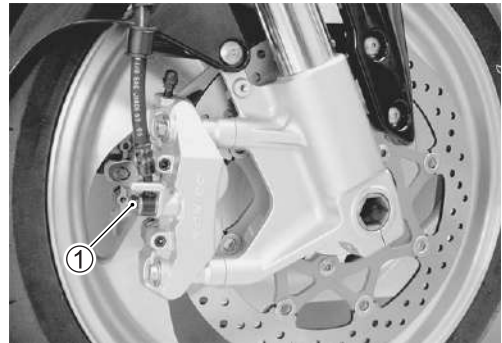



## CALIPER DISASSEMBLY

- Remove the pad spring ①.

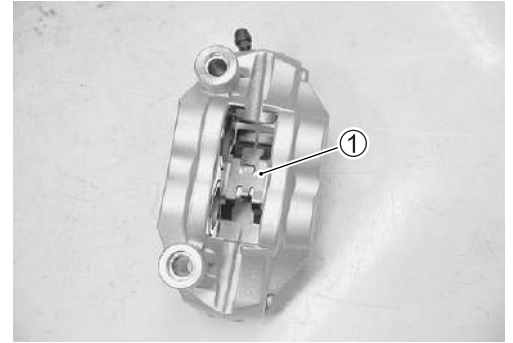

- Remove the caliper air bleeder valve ②.
- Separate the caliper halves by removing the caliper housing bolts ③ with the special tools.

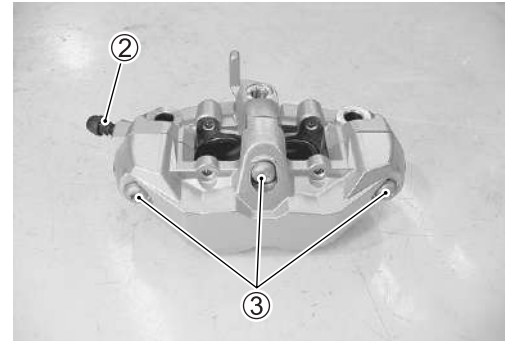

**TOOL** 09930-11920: Torx bit JT40H  
09930-11940: Bit holder

- Remove the O-ring ④.

### CAUTION

Replace the O-ring with a new one.

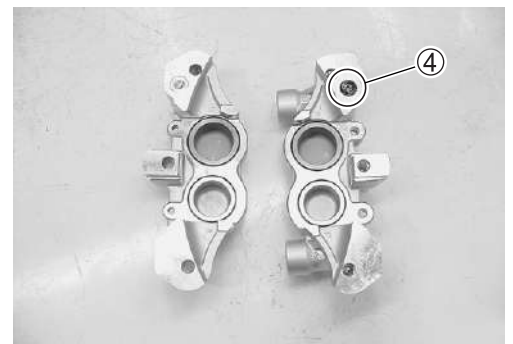

- Place a rag over the pistons to prevent it from popping out and then force out the pistons using compressed air.

### CAUTION

Avoid using high pressure air to prevent piston damage.



- Remove the dust seals ⑤ and piston seals ⑥.

### CAUTION

Avoid reusing the dust seals and piston seals to prevent fluid leakage.

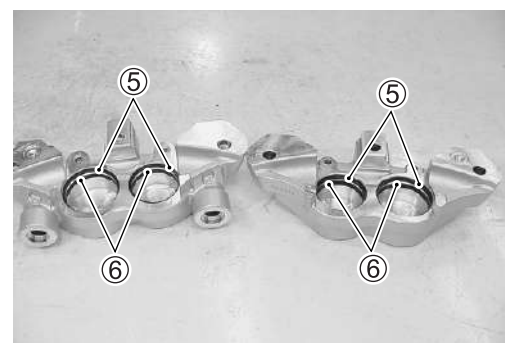



## CALIPER INSPECTION

### BRAKE CALIPER

- Inspect the brake caliper cylinder wall for nicks, scratches or other damage. If any damage is found, replace it with a new one.

### BRAKE CALIPER PISTON

- Inspect the brake caliper piston surface for any scratches or other damage. If any damage is found, replace it with a new one.

### BRAKE PAD SPRING

Inspect the brake pad spring for damage excessive bend. If any damage is found, replace it with a new one.

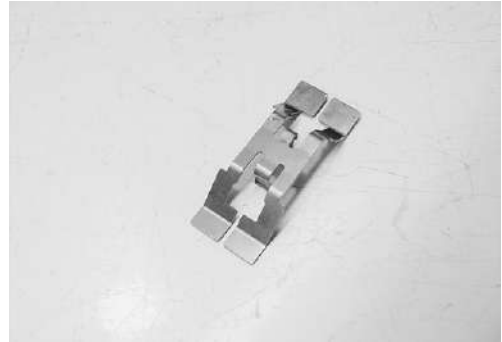

## CALIPER REASSEMBLY

Reassemble the caliper in the reverse order of disassembly. Pay attention to the following points:

- Clean the caliper bores and pistons with specified brake fluid, especially the dust seal grooves and piston seal grooves.

**BF** Specification and classification: DOT 4

### CAUTION

- \* Clean the caliper components with fresh brake fluid before reassembly. Never use cleaning solvent or gasoline to clean them.
- \* Do not wipe the brake fluid off after cleaning the components.
- \* When cleaning the components, use the specified brake fluid. Never use different types of fluid or cleaning solvent such as gasoline, kerosine or others.
- \* Replace the piston seals and dust seals with the new ones when installing them. Apply the brake fluid to both seals when installing them.

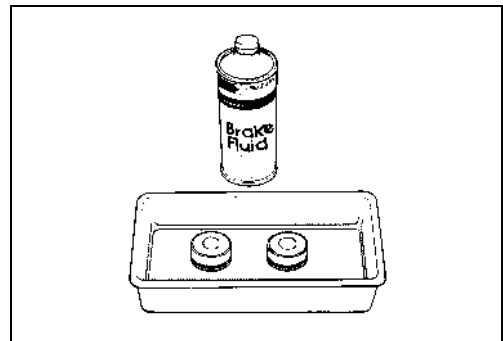

**PISTON SEAL**

- Install the piston seals as shown in the illustration.

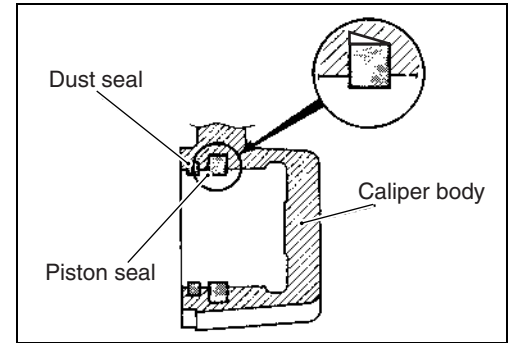
**O-RING**

- Install the new O-ring ① and reassemble caliper halves.

**CAUTION**

Replace the O-ring with a new one.

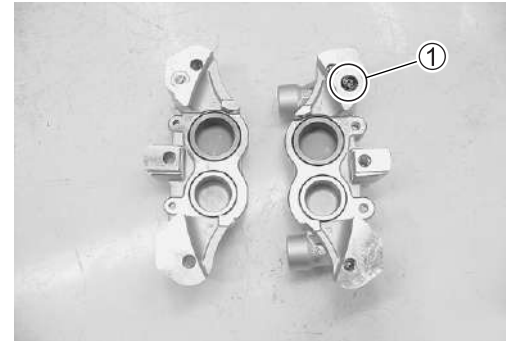

- Temporarily tighten the air bleeder valve ②.
- Tighten each bolt to the specified torque.

 **Front brake caliper housing bolt ③:**  
22 N·m (2.2 kgf·m, 16.0 lb·ft)

 **09930-11920: Torx bit JT40H**  
**09930-11940: Bit holder**

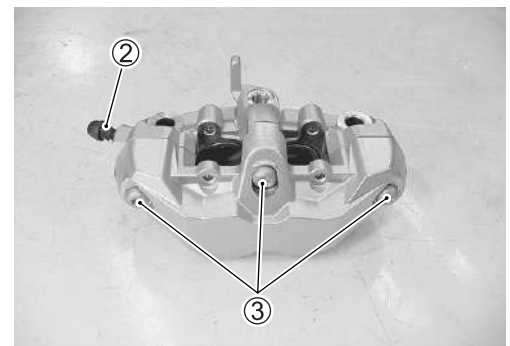

- Install the spring to the caliper, bring its wider side of pawl Ⓐ facing top.

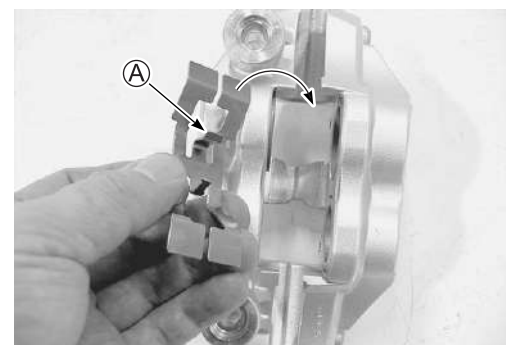

## CALIPER INSTALLATION

Install the caliper in the reverse order of removal. Pay attention to the following points:

- Install the brake pads and brake caliper. (☞ 9-53)
- to the specified torque.

**🔧 Brake hose union bolt: 23 N·m (2.3 kgf·m, 16.5 lb-ft)**

### CAUTION

- \* The seal washers should be replaced with the new ones to prevent brake fluid leakage.
- \* Bleed air from the system after reassembling the caliper. (☞ 2-26)

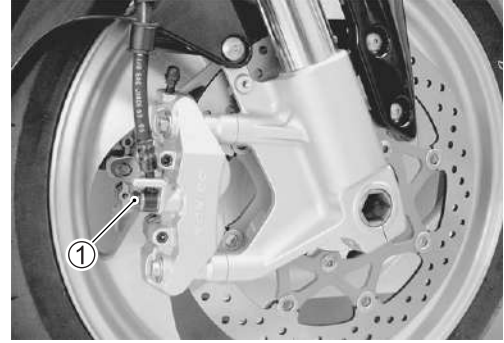

## BRAKE DISC INSPECTION

- Visually check the brake disc for damage or cracks.
- Measure the thickness with a micrometer.
- Replace the disc if the thickness is less than the service limit or if damage is found.

**DATA** Front disc thickness: Service Limit: 4.5 mm (0.18 in)

**🔧** 09900-20205: Micrometer (0 – 25 mm)

- Remove the brake calipers. (☞ 9-52 and -63)
- Measure the runout with a dial gauge.
- Replace the disc if the runout exceeds the service limit.

**DATA** Front disc runout: Service Limit: 0.30 mm (0.012 in)

**🔧** 09900-20607: Dial gauge (1/100 mm)

09900-20701: Magnetic stand

- \* Brake disc removal (☞ 9-9 and -35)
- \* Brake disc installation (☞ 9-12 and -38)

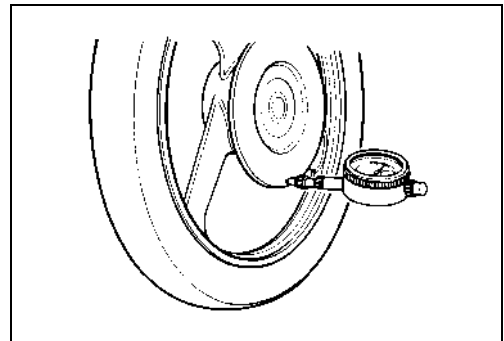
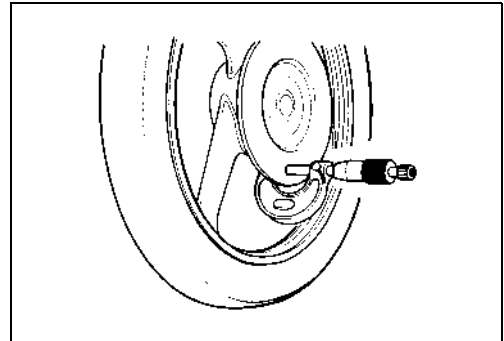

## MASTER CYLINDER REMOVAL AND DISASSEMBLY

- Drain the brake fluid. (☞ 9-53)
- Disconnect the front brake light switch lead wire coupler ①.
- Place a rag underneath the union bolt ② on the master cylinder to catch any split brake fluid. Remove the union bolt and disconnect the brake hose.

### CAUTION

**Immediately and completely wipe off any brake fluid contacting any part of the motorcycle. The fluid reacts chemically with paint, plastics and rubber materials, etc. and will damage them severely.**

- Remove the right rear view mirror ③ and master cylinder assembly ④.

- Remove the front brake light switch ⑤.
- Remove the nut and bolt ⑥ and brake lever ⑦.

- Remove the dust boot ⑧ and the snap ring ⑨.

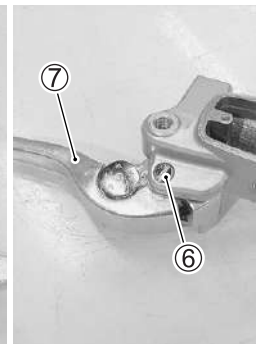
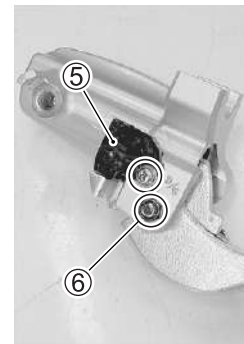
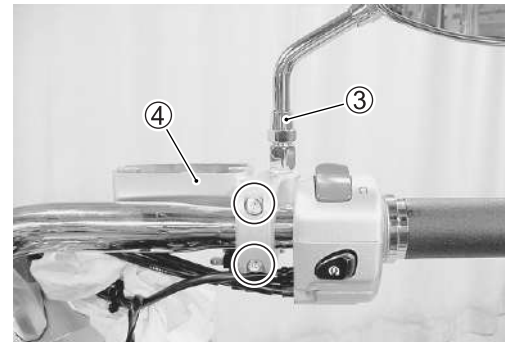
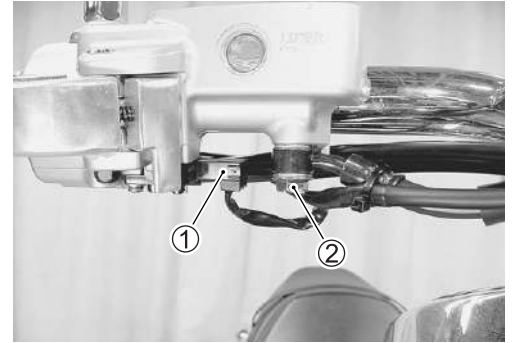

- Remove the following parts.

- ⑩ Piston
- ⑪ Secondary cup
- ⑫ Primary cup
- ⑬ Return spring

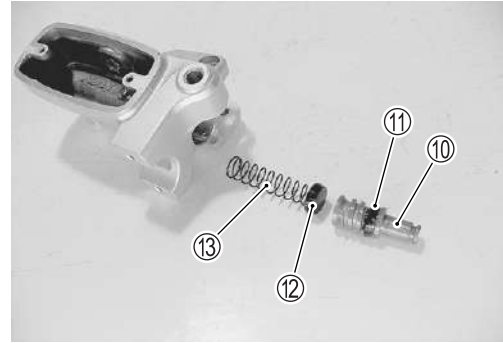

## MASTER CYLINDER INSPECTION

### MASTER CYLINDER

- Inspect the master cylinder bore for any scratches or damage. If any defects are found, replace the master cylinder with a new one.



### PISTON AND RUBBER PARTS

- Inspect the piston surface for any scratches or other damage.
- Inspect the primary cup, secondary cup, dust boot and return spring for wear or damage.



## MASTER CYLINDER REASSEMBLY

Reassemble the master cylinder in the reverse order of disassembly. Pay special attention to the following points:

### CAUTION

- \* Wash the master cylinder components with new brake fluid before reassembly.
- \* Do not wipe the brake fluid off after washing the components.
- \* When washing the components, use the specified brake fluid. Never use different types of fluid or cleaning solvents such as gasoline, kerosine, etc.
- \* Apply brake fluid to the master cylinder bore and all of the master cylinder components before reassembly.

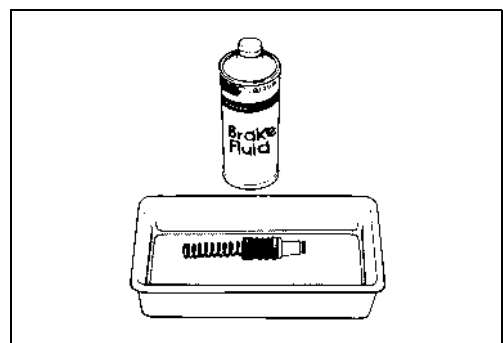

Specification and classification: DOT 4

- Apply SUZUKI SUPER GREASE “A” to the bolt and brake lever end.

 **99000-25010: SUZUKI SUPER GREASE “A”**  
or equivalent

- Tighten the pivot bolt and nut.

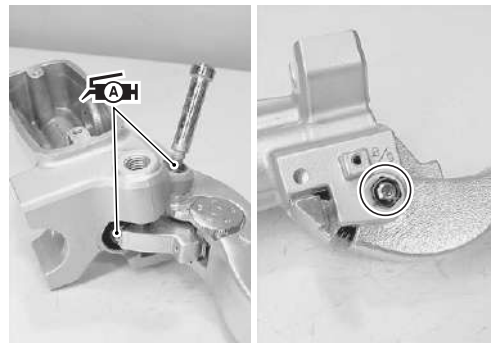

- When installing the brake light switch, align the projection on the switch with the hole in the master cylinder.





## MASTER CYLINDER INSTALLATION

Install the master cylinder in the reverse order of removal. Pay attention to the following points:

- When remounting the master cylinder onto the handlebars, align the master cylinder holder's mating surface with the punch mark **A** on the handlebars and tighten the upper clamp bolt first.

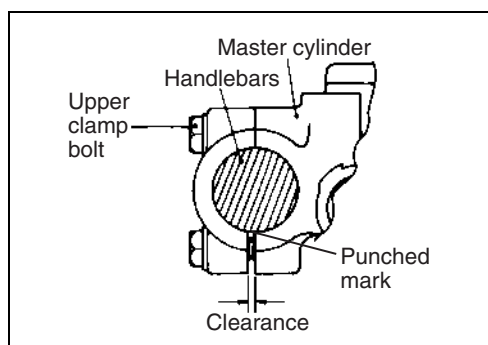
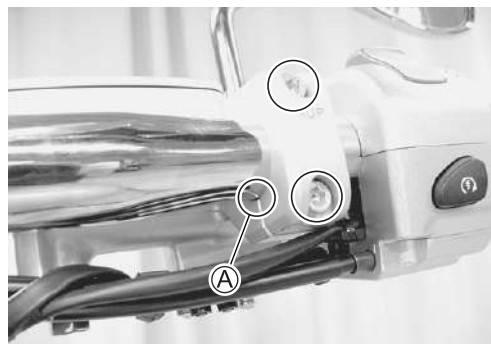
 **Master cylinder mount bolt: 10 N·m (1.0 kgf·m, 7.0 lb·ft)**



- Tighten the brake hose union bolt to the specified torque.
- Brake hose routing. ( 11-39)

 **Brake hose union bolt: 23 N·m (2.3 kgf·m, 16.5 lb·ft)**

### CAUTION

- \* The seal washers should be replaced with the new ones to prevent brake fluid leakage.
- \* Bleed air from the system after reassembling the master cylinder. ( 2-26)





# REAR BRAKE CONSTRUCTION

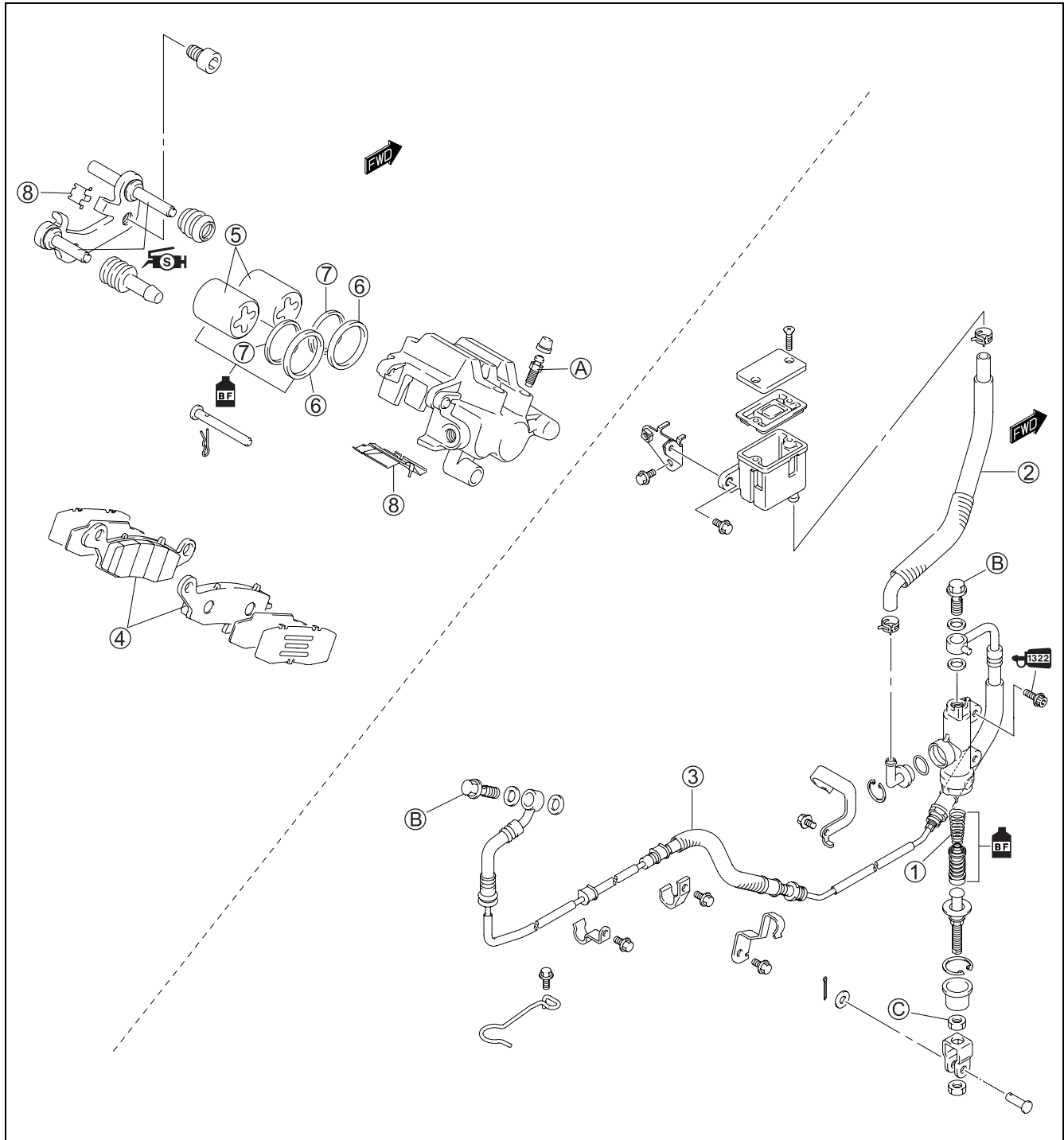

①	Piston/Cup set	⑦	Dust seal
②	Reservoir hose	⑧	Brake pad spring
③	Brake hose	A	Caliper air bleeder valve
④	Brake pad	B	Brake hose union bolt
⑤	Piston	C	Brake master cylinder rod lock nut
⑥	Piston seal		



ITEM	N-m	kgf-m	lb-ft
A	7.5	0.75	5.5
B	23	2.3	16.5
C	18	1.8	13.0

**⚠ WARNING**

- \* This brake system is filled with an ethylene glycol-based DOT 4 brake fluid. Do not use mix different types of fluid such as silicone-based or petroleum-based.
- \* Do not use any brake fluid taken from old, used or unsealed containers. Never reuse brake fluid left over from the last servicing or stored for long periods.
- \* When storing the brake fluid, seal the container completely and keep away from children.
- \* When replenishing brake fluid, take care not to get dust into fluid.
- \* When washing brake components, use fresh brake fluid. Never use cleaning solvent.
- \* A contaminated brake disc or brake pad reduces braking performance. Discard contaminated pads and clean the disc with high quality brake cleaner or neutral detergent.

**CAUTION**

Handle brake fluid with care: The fluid reacts chemically with paint, plastics, rubber materials etc. and will damage them severely.

**BRAKE PAD REPLACEMENT**

- Remove the brake caliper by removing the brake caliper mounting bolts.

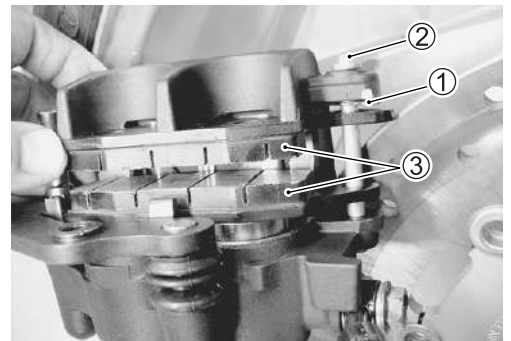

- Remove the cotter pin ①.
- Remove the pad mounting pin ②.
- Remove the brake pads ③.

**CAUTION**

- \* Do not operate the brake pedal with the pads removed.
- \* Replace the brake pads as a set, otherwise braking performance will be adversely affected.

**NOTE:**

- \* When the brake caliper is removed, care must be used so as not to cause stress to the brake hose. (Hang the brake caliper on the frame with a string, etc.)
- \* When removing the brake pad, push the piston all the way into the brake caliper.

- Inspect the pad mounting pin for bent or damage. If any defects are found, replace the pad mounting pins with the new ones.



- Install the new brake pads.
- Install the brake caliper.
- Tighten the rear brake caliper mounting bolt to the specified torque.

**🔧 Rear brake caliper mounting bolt:**

**39 N·m (3.9 kgf-m, 28.0 lb-ft)**

**NOTE:**

*After replacing the brake pads, pump the brake pedal a few times to check for proper brake operation and then check the brake fluid level.*



## BRAKE FLUID REPLACEMENT

- Remove the right frame head cover and right radiator cover. (👉 9-6)
- Place the motorcycle on a level surface.
- Remove the brake fluid reservoir cap ① and diaphragm.
- Drain the old brake fluid as much as possible.
- Fill the reservoir with new brake fluid.

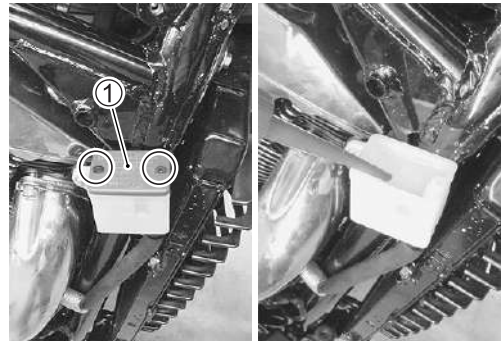

- Connect a clear hose to the caliper air bleeder valve and insert the other end of hose into a receptacle.
- Loosen the air bleeder valve and pump the brake pedal until old brake fluid flows out of the bleeder system.
- Close the caliper air bleeder valve and disconnect a clear hose. Fill the reservoir with new fluid to the upper mark of the reservoir.

 **Specification and classification: DOT 4**

#### CAUTION

**Bleed air from the brake system. (☞ 2-26)**

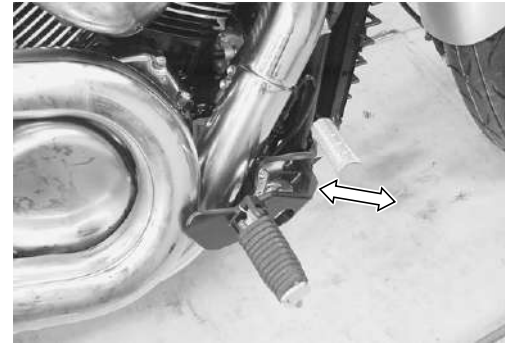
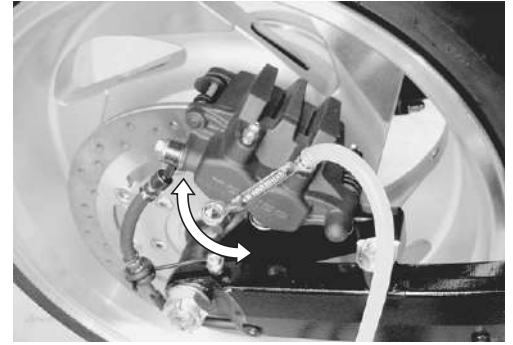

## CALIPER REMOVAL

- Remove the brake hose from the caliper by removing the union bolt ① and catch the brake fluid in a suitable receptacle.

#### NOTE:

*Place a rag underneath the union bolt on the brake caliper to catch any split brake fluid.*

- Remove the brake caliper. (☞ 9-63)

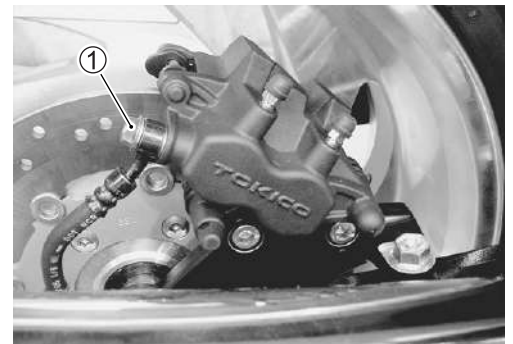

#### CAUTION

**Never reuse the brake fluid left over from previous servicing and stored for long periods of time.**

#### ⚠ WARNING

**Brake fluid, if it leaks, will interfere with safe running and discolor painted surfaces. Check the brake hose and hose joints for cracks and fluid leakage.**

## CALIPER DISASSEMBLY

- Remove the brake pads. (☞ 9-63)
- Remove the springs ① and brake caliper holder ②.

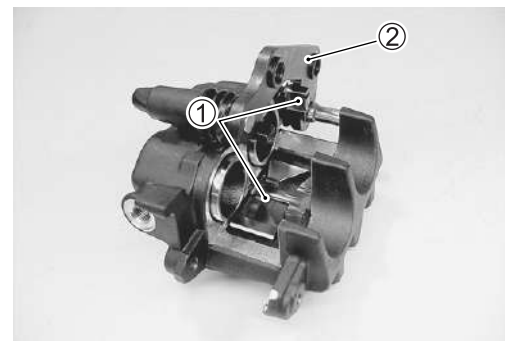

- Remove the caliper air bleeder valves ③.



- Remove the rubber boots ④.

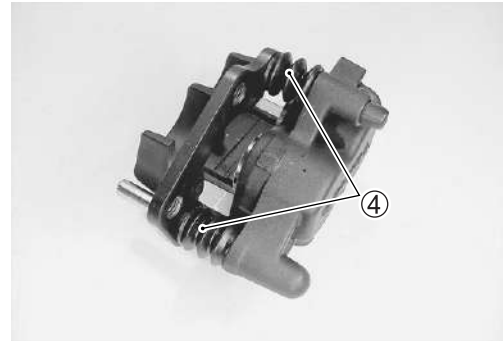

- Place a rag over the brake caliper pistons to prevent them from popping out, and then force out the pistons using compressed air.

**CAUTION**

**Do not use extremely high pressure to remove the brake caliper pistons, otherwise damage to the pistons will result.**



- Remove the dust seals ⑤ and piston seals ⑥.

**CAUTION**

**Do not reuse the dust seals and piston seals to prevent brake fluid leakage.**

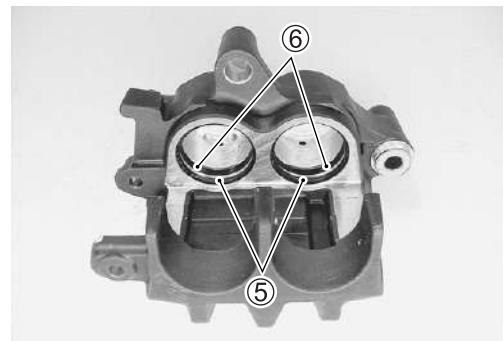

## CALIPER INSPECTION

### BRAKE CALIPER

- Inspect each brake caliper cylinder wall for nicks, scratches or other damage. If any defects are found, replace the brake caliper with a new one.

### BRAKE CALIPER PISTONS

- Inspect the brake caliper pistons for any scratches or other damage. If any defects are found, replace the piston with a new one.



**BRAKE CALIPER HOLDER**

- Inspect the brake caliper holder for wear and other damage. If any defects are found, replace the holder with a new one.

**RUBBER BOOT**

- Inspect the rubber boot for damage and wear. If any defects are found, replace the boots with new ones.

**BRAKE PAD SPRING**

- Inspect the brake pad spring for damage and excessive bend. If any defects are found, replace the brake pad spring with a new one.

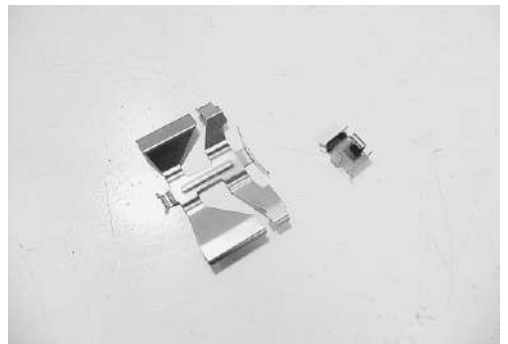



## CALIPER REASSEMBLY

Reassemble the caliper in the reverse order of disassembly. Pay attention to the following points:

- Clean the caliper bores and pistons with specified brake fluid, especially the dust seal grooves and piston seal grooves.



**Specification and classification: DOT 4**

### CAUTION

- \* Clean the caliper components with fresh brake fluid before reassembly. Never use cleaning solvent or gasoline to clean them.
- \* Do not wipe the brake fluid off after cleaning the components.
- \* When cleaning the components, use the specified brake fluid. Never use different types of fluid or cleaning solvent such as gasoline, kerosine the others.
- \* Replace the piston seals and dust seals with new ones when installing them. Apply the brake fluid to both seals when installing them.

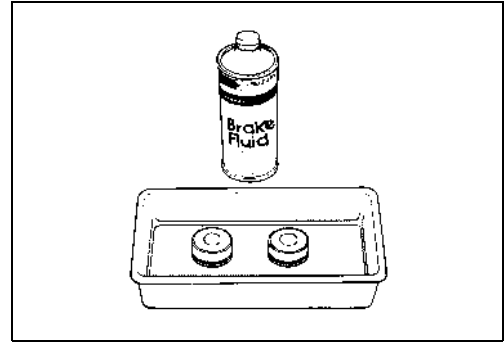

## PISTON SEAL

- Install the piston seals as shown in the illustration.

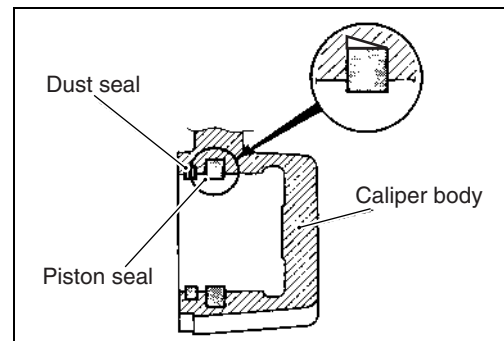

## BRAKE CALIPER HOLDER

- Apply SUZUKI SILICON GREASE to the brake caliper holder.



**99000-25100: SUZUKI SILICONE GREASE**

**or equivalent**

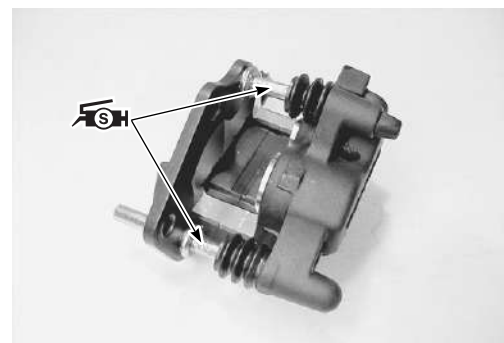

## RUBBER BOOT

- Set the rubber boot onto the brake caliper.

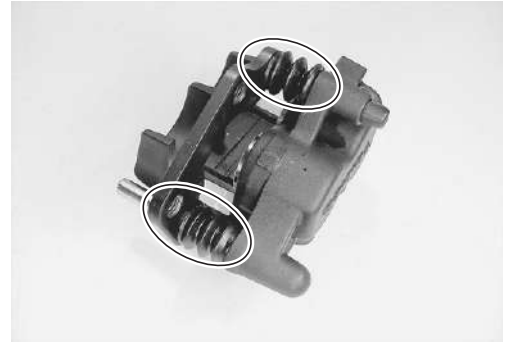

## CALIPER INSTALLATION

Install the caliper in the reverse order of removal. Pay attention to the following points:

- Install the brake pads and brake caliper. (↗9-64)
- Tighten brake hose union bolt to the specified torque.  
(Rear brake hose routing:↗11-40)

**🔧 Brake hose union bolt: 23 N·m (2.3 kgf·m, 16.5 lb-ft)**

### CAUTION

- \* The seal washers should be replaced with the new ones to prevent brake fluid leakage.
- \* Bleed air from the system after reassembling the caliper. (↗2-26)



## BRAKE DISK INSPECTION (↗9-58)

**DATA** Rear disc thickness: Service Limit: 6.3 mm (0.25 in)

## MASTER CYLINDER REMOVAL

- Remove the right frame head cover and right radiator cover. (↗9-6)
- Remove the exhaust pipe and muffler. (↗7-8)
- Drain the brake fluid. (↗9-64)

### NOTE:

*Temporarily tighten the reservoir cap.*

- Remove the brake fluid reservoir mounting bolt.

- Remove the master cylinder cover ①.

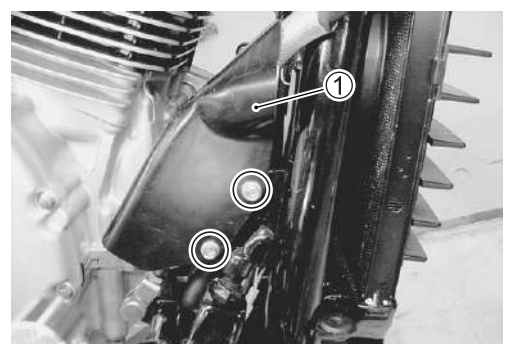

- Temporarily tighten the master cylinder mounting bolts ②.
- Place a rag underneath the union bolt on the master cylinder to catch spilled drops of brake fluid. Remove the union bolt ③ and disconnect the brake hose.
- Loosen the lock nut ④.
- Disconnect the reservoir hose ⑤.
- Remove the mounting bolts ②.
- Remove the master cylinder by turning the master cylinder rod ⑥.

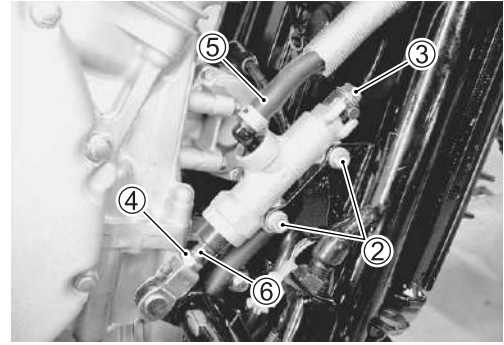

**CAUTION**

Immediately and completely wipe off any brake fluid contacting any parts of the motorcycle. The fluid reacts chemically with paint, plastic and rubber materials, etc. and will damage them severely.

**MASTER CYLINDER DISASSEMBLY**

- Remove the reservoir cap ① and diaphragm ②.

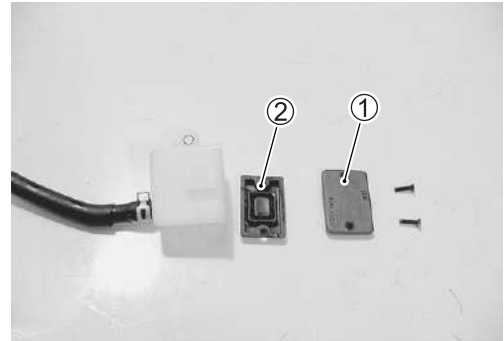

- Remove the snap ring ③, connector ④ and O-ring ⑤.

**TOOL** 09900-06108: Snap ring pliers

**CAUTION**

Replace the removed O-ring ⑤ with a new one.

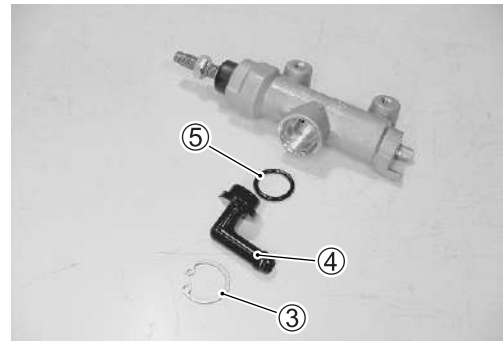

- Pull out the dust boot ⑥, then remove the snap ring ⑦.

**TOOL** 09900-06108: Snap ring pliers

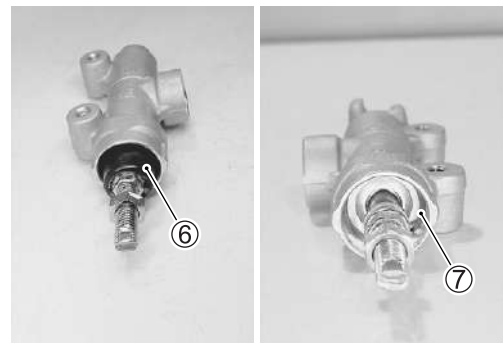

- Remove the push rod ⑧, piston/primary cup ⑨ and spring ⑩.

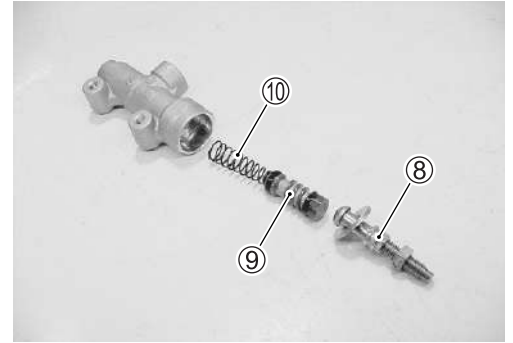

## MASTER CYLINDER INSPECTION

### CYLINDER, PISTON

- Inspect the cylinder bore wall for any scratches or other damage.

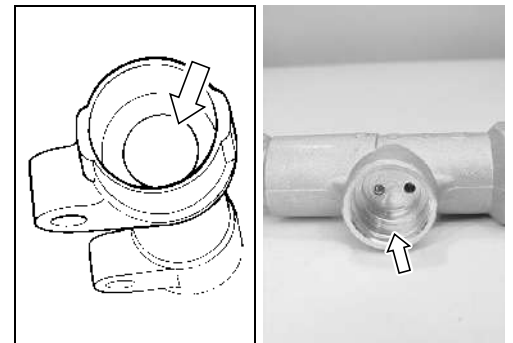

### CUP SET

- Inspect the cup set.

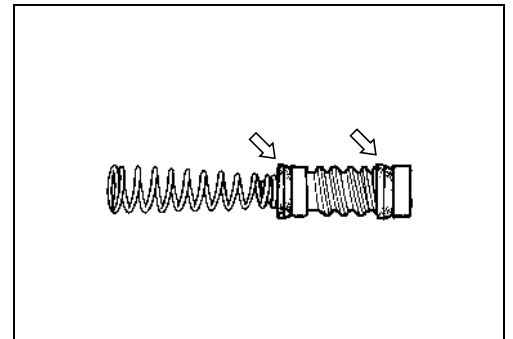

## MASTER CYLINDER REASSEMBLY

Reassemble the master cylinder in the reverse order of disassembly. Pay attention to the following points:

### CAUTION

- \* Clean the master cylinder components with fresh brake fluid before reassembly. Never use cleaning solvent or gasoline to clean them.
- \* Do not wipe the components with a rag.
- \* Apply brake fluid to the cylinder bore and all the component to be inserted into the bore.

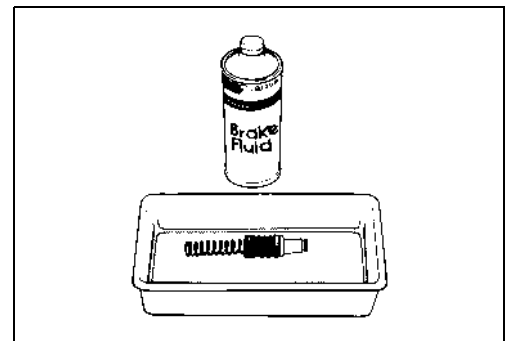

Specification and classification: DOT 4

- Apply SUZUKI SILICONE GREASE to the push rod end.

 99000-25100: SUZUKI SILICONE GREASE  
or equivalent

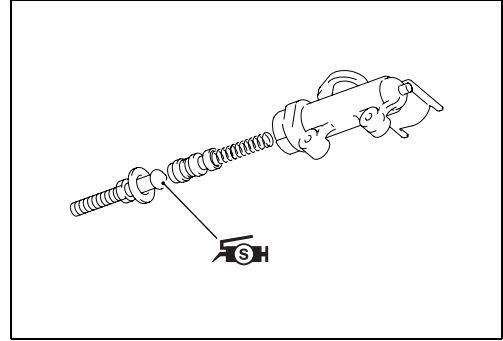

- Install the O-ring ① and connector ② to the master cylinder.

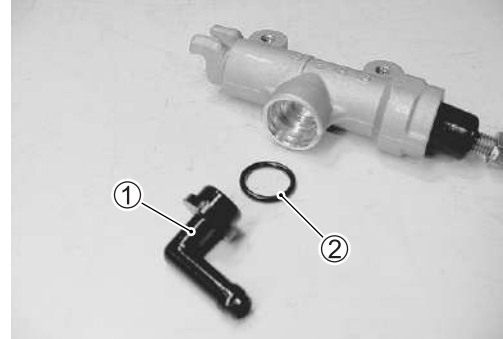

## MASTER CYLINDER INSTALLATION

Install the master cylinder in the reverse order of removal. Pay attention to the following points:

- Temporarily tighten the master cylinder mounting bolts.
- Tighten the lock nut ① and brake hose union bolt ② to the specified torque. (Brake hose routing:  11-40)

 Master cylinder rod lock nut ①:

**18 N·m (1.8 kgf-m, 13.0 lb-ft)**

**Brake hose union bolt ②: 23 N·m (2.3 kgf-m, 16.5 lb-ft)**

- Remove the master cylinder mounting bolts.
- Apply THREAD LOCK SUPER to the master cylinder mounting bolts.

 99000-32110: THREAD LOCK SUPER "1322"  
or equivalent

- Tighten the master cylinder mounting bolts to the specified torque.

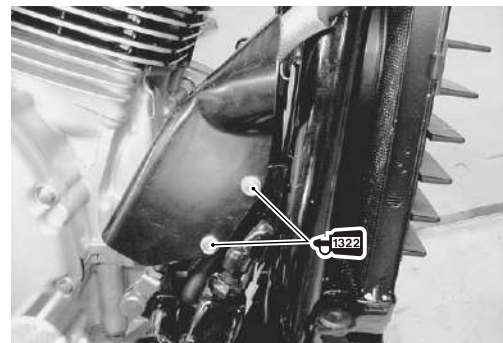
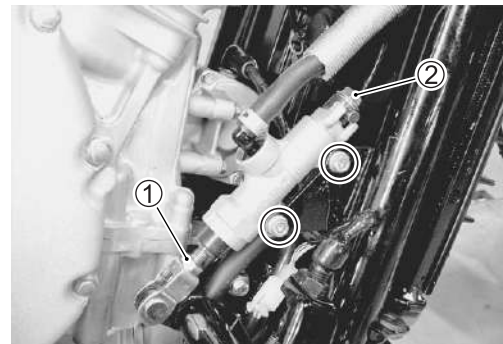

 Master cylinder mounting bolt:

**10 N·m (1.0 kgf-m, 7.0 lb-ft)**



### CAUTION

- \* The seal washers should be replaced with the new ones to prevent brake fluid leakage.
- \* Bleed air from the system after reassembling the master cylinder. ( 2-26)

- Adjust the brake pedal height. ( 2-25)
- Install the right frame head cover and right radiator cover. ( 9-7)

## TIRE AND WHEEL

### TIRE REMOVAL

The most critical factor of tubeless tire is the seal between the wheel rim and the tire bead. For this reason, it is recommended to use a tire changer that can satisfy this sealing requirement and can make the operation efficient as well as functional.

For operating procedures, refer to the instructions supplied by the tire changer manufacturer.

#### NOTE:

*When removing the tire in the case of repair or inspection, mark the tire with a chalk to indicate the tire position relative to the valve position.*

*Even though the tire is refitted to the original position after repairing puncture, the tire may have to be balanced again since such a repair can cause imbalance.*

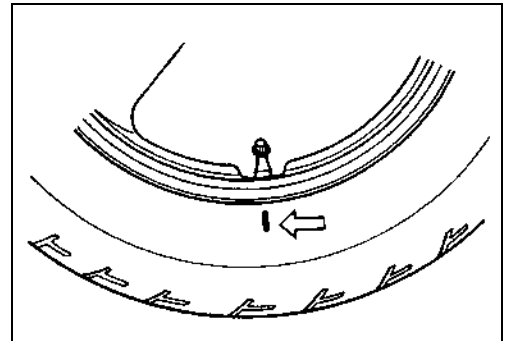

## INSPECTION

### WHEEL

Wipe the wheel clean and check for the following:

- Distortion and crack
- Any flaws and scratches at the bead seating area.
- Wheel rim runout (☞ 9-10)

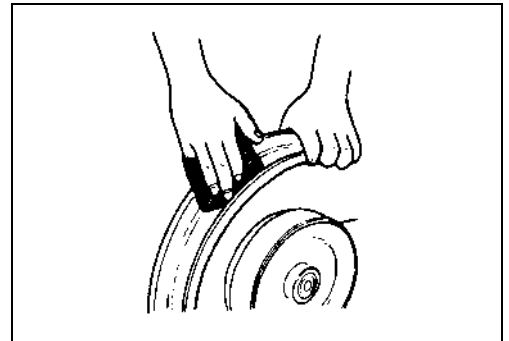

### TIRE

Tire must be checked for the following points:

- Nick and rupture on side wall
- Tire tread depth (☞ 2-27)
- Tread separation
- Abnormal, uneven wear on tread
- Surface damage on bead
- Localized tread wear due to skidding (Flat spot)
- Abnormal condition of inner liner

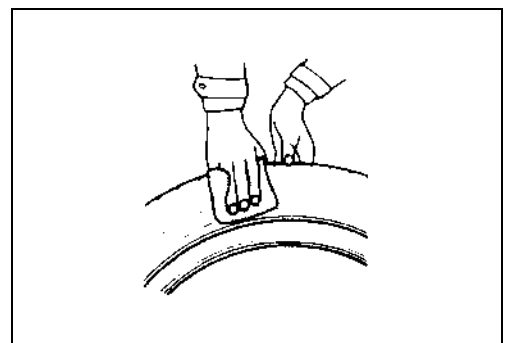



## VALVE INSPECTION

- Inspect the valve after the tire is removed from the rim.
- Replace the valve with a new one if the seal (A) rubber is peeling or has damage.

### NOTE:

*If the external appearance of the valve shows no abnormal condition, removing of the valve is not necessary.*

*If the seal has abnormal deformation, replace the valve with a new one.*

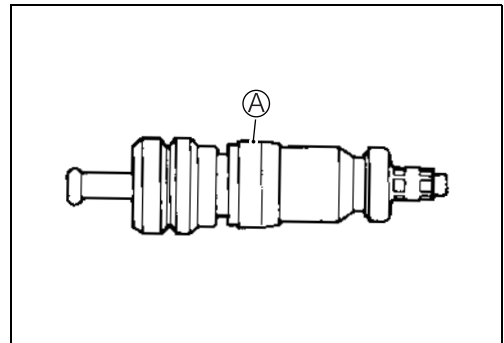
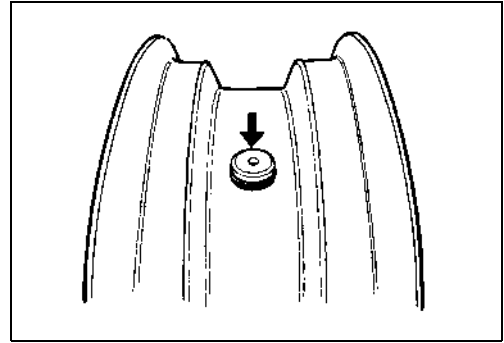

- Any dust or rust around the valve hole (B) must be cleaned off.
- Then install the valve (C) in the rim.

### NOTE:

*To properly install the valve into the valve hole, apply a special tire lubricant or neutral soapy liquid to the valve.*

### CAUTION

**Be careful not to damage the lip (C) of valve.**

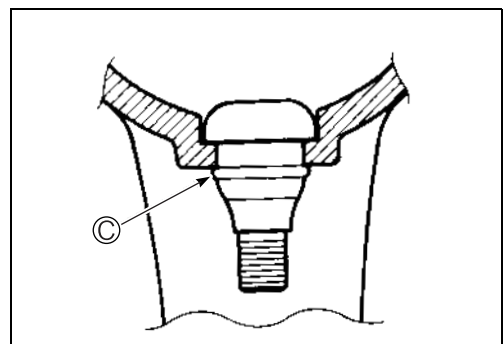
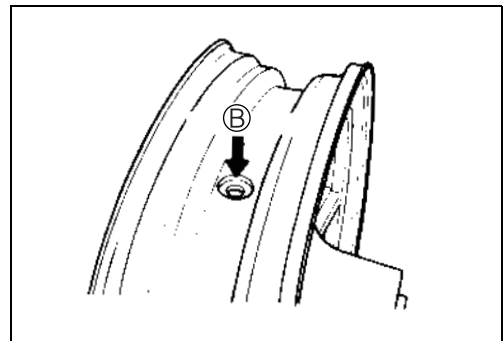

## TIRE INSTALLATION

- Apply tire lubricant to the tire bead.
- When installing the tire onto the wheel, observe the following points.

### CAUTION

- \* Do not reuse the valve which has been once removed.
- \* Never use oil, grease or gasoline on the tire bead in place of tire lubricant.

- When installing the tire, the arrow  $\text{\textcircled{A}}$  on the side wall should point to the direction of wheel rotation.
- Align the chalk mark put on the tire at the time of removal with the valve position.

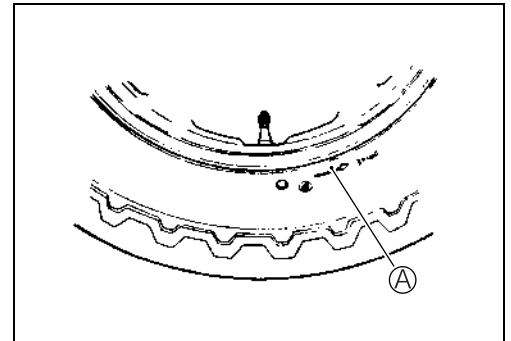
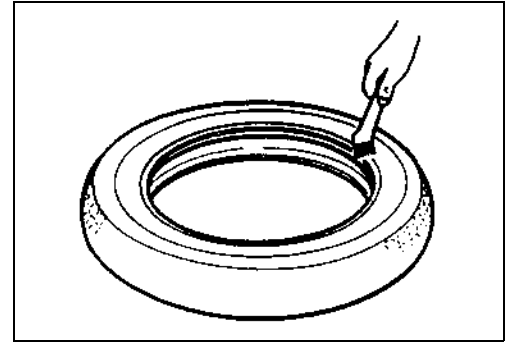

- For installation procedure of tire onto the wheel, follow the instructions given by the tire changer manufacturer.
- Bounce the tire several times while rotating. This makes the tire bead expand outward to contact the wheel, thereby facilitating air inflation.
- Inflate the tire.

### ⚠ WARNING

- \* Do not inflate the tire to more than 400 kPa (4.0 kgf/cm<sup>2</sup>, 57 psi). If inflated beyond this limit, the tire can burst and possibly cause injury. Do not stand directly over the tire while inflating.
- \* In the case of preset pressure air inflator, pay special care for the set pressure adjustment.

- In this condition, check the “rim line” ⑥ cast on the tire side walls. The line must be equidistant from the wheel rim all around. If the distance between the rim line and wheel rim varies, this indicates that the bead is not properly seated. If this is the case, deflate the tire completely and unseat the bead for both sides. Coat the bead with lubricant and fit the tire again.
- When the bead has been fitted properly, adjust the pressure to specification.
- As necessary, adjust the tire balance.

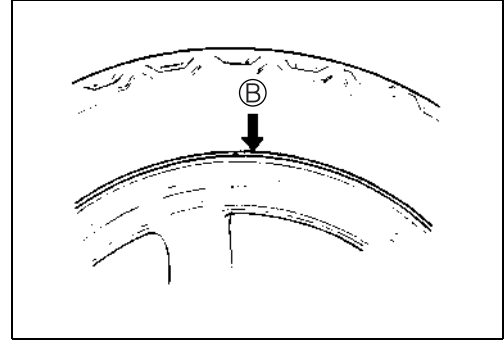
**CAUTION**

**Do not run with a repaired tire at a high speed.**

**DATA** Cold inflation tire pressure

	Front	Rear
<b>Solo riding</b>	250 kPa (2.50 kgf/cm <sup>2</sup> , 36 psi)	290 kPa (2.90 kgf/cm <sup>2</sup> , 42 psi)
<b>Dual riding</b>	250 kPa (2.50 kgf/cm <sup>2</sup> , 36 psi)	290 kPa (2.90 kgf/cm <sup>2</sup> , 42 psi)

**BALANCER WEIGHT INSTALLATION**

- When installing the balancer weights to the wheel, set the two balancer weights ① on both sides of wheel rim.

**CAUTION**

**Weight difference between the two balancer weights must be less than 10 g (0.02 lb).**

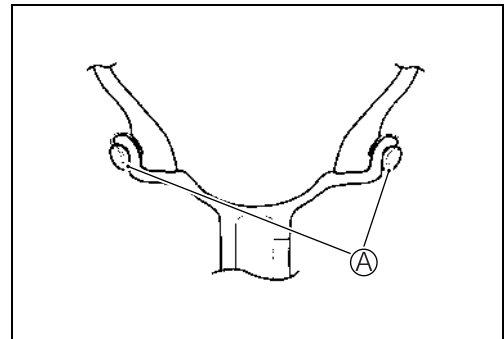

# ELECTRICAL SYSTEM

## CONTENTS

<b>CAUTIONS IN SERVICING .....</b>	<b>10- 3</b>
<b>CONNECTOR.....</b>	<b>10- 3</b>
<b>COUPLER.....</b>	<b>10- 3</b>
<b>CLAMP .....</b>	<b>10- 3</b>
<b>FUSE.....</b>	<b>10- 3</b>
<b>SEMI-CONDUCTOR EQUIPPED PART .....</b>	<b>10- 4</b>
<b>BATTERY .....</b>	<b>10- 4</b>
<b>CONNECTING THE BATTERY.....</b>	<b>10- 4</b>
<b>WIRING PROCEDURE.....</b>	<b>10- 4</b>
<b>USING THE MULTI-CIRCUIT TESTER.....</b>	<b>10- 5</b>
<b>LOCATION OF ELECTRICAL COMPONENTS .....</b>	<b>10- 6</b>
<b>CHARGING SYSTEM .....</b>	<b>10- 8</b>
<b>TROUBLESHOOTING.....</b>	<b>10- 8</b>
<b>INSPECTION .....</b>	<b>10- 9</b>
<b>STARTER SYSTEM AND SIDE-STAND/ IGNITION INTERLOCK SYSTEM .....</b>	<b>10-12</b>
<b>TROUBLESHOOTING.....</b>	<b>10-12</b>
<b>STARTER MOTOR REMOVAL.....</b>	<b>10-14</b>
<b>STARTER MOTOR DISASSEMBLY.....</b>	<b>10-15</b>
<b>STARTER MOTOR INSPECTION.....</b>	<b>10-15</b>
<b>STARTER MOTOR REASSEMBLY.....</b>	<b>10-16</b>
<b>STARTER RELAY INSPECTION.....</b>	<b>10-18</b>
<b>SIDE STAND/IGNITION INTERLOCK SYSTEM PARTS     INSPECTION .....</b>	<b>10-19</b>
<b>IGNITION SYSTEM .....</b>	<b>10-22</b>
<b>TROUBLESHOOTING.....</b>	<b>10-23</b>
<b>INSPECTION .....</b>	<b>10-25</b>
<b>SPEEDOMETER AND TACHOMETER .....</b>	<b>10-30</b>
<b>DESCRIPTION.....</b>	<b>10-30</b>
<b>SPEEDOMETER REMOVAL AND DISASSEMBLY.....</b>	<b>10-31</b>
<b>TACHOMETER REMOVAL AND DISASSEMBLY.....</b>	<b>10-32</b>
<b>INSPECTION .....</b>	<b>10-33</b>

# ELECTRICAL SYSTEM

## CONTENTS

<b>LAMPS .....</b>	<b>10-39</b>
<b>HEADLIGHT, BRAKE LIGHT/TAILLIGHT, LICENSE PLATE</b>	
<b>LIGHT AND TURN SIGNAL LIGHT .....</b>	<b>10-39</b>
<b>HEADLIGHT RELAY INSPECTION .....</b>	<b>10-40</b>
<b>RELAYS .....</b>	<b>10-41</b>
<b>TURN SIGNAL/SIDE-STAND RELAY .....</b>	<b>10-41</b>
<b>STARTER RELAY .....</b>	<b>10-41</b>
<b>FUEL PUMP RELAY .....</b>	<b>10-41</b>
<b>COOLING FAN RELAY .....</b>	<b>10-41</b>
<b>SWITCHES INSPECTION .....</b>	<b>10-42</b>
<b>BATTERY .....</b>	<b>10-43</b>
<b>SPECIFICATIONS .....</b>	<b>10-43</b>
<b>INITIAL CHARGING .....</b>	<b>10-43</b>
<b>SERVICING .....</b>	<b>10-45</b>
<b>RECHARGING OPERATION .....</b>	<b>10-45</b>

## CAUTIONS IN SERVICING

### CONNECTOR

- When connecting a connector, be sure to push it in until a click is felt.
- Inspect the connector for corrosion, contamination and breakage in its cover.

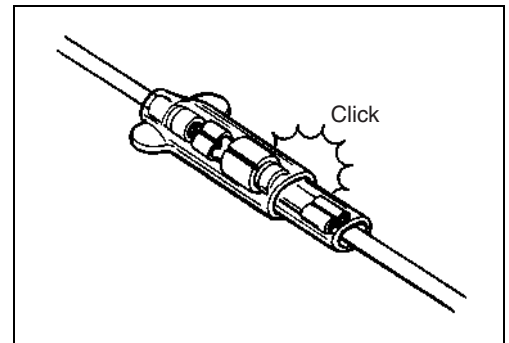

### COUPLER

- With a lock type coupler, be sure to release the lock when disconnecting, and push in fully to engage the lock when connecting.
- When disconnecting the coupler, be sure to hold the coupler itself and do not pull the lead wires.
- Inspect each terminal on the coupler for being loose or bent.
- Inspect each terminal for corrosion and contamination.

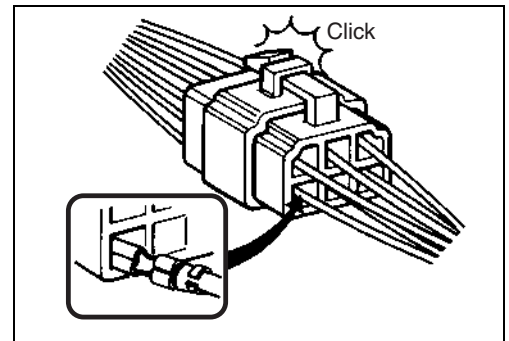

### CLAMP

- Clamp the wire harness at such positions as indicated in "WIRING HARNESS ROUTING". (☞ 11-35 to -37)
- Bend the clamp properly so that the wire harness is clamped securely.
- In clamping the wire harness, use care not to allow it to hang down.
- Do not use wire or any other substitute for the band type clamp.

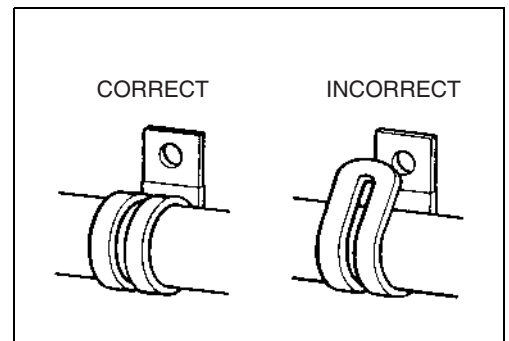

### FUSE

- When a fuse blows, always investigate the cause to correct it and then replace the fuse.
- Do not use a fuse of a different capacity.
- Do not use wire or any other substitute for the fuse.

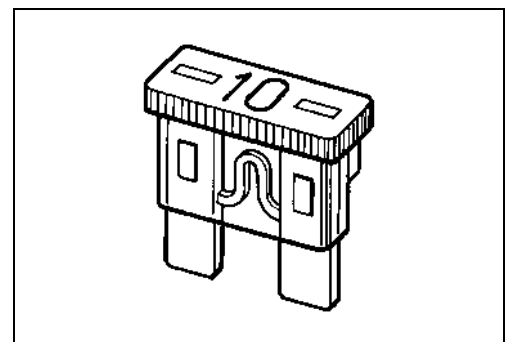



## SEMI-CONDUCTOR EQUIPPED PART

- Be careful not to drop the part with a semi-conductor built in such as a ECM.
- When inspecting this part, follow inspection instruction strictly. Neglecting proper procedure may cause damage to this part.

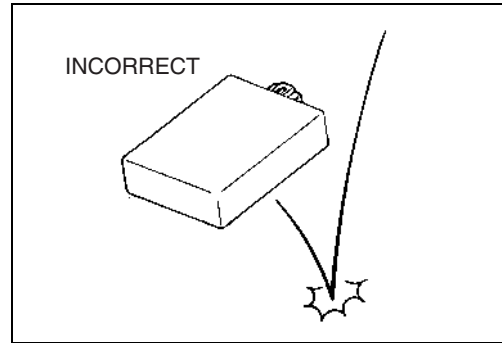

## BATTERY

- The MF battery used in this motorcycle does not require maintenance (e.g., electrolyte level inspection, distilled water replenishment).
- During normal charging, no hydrogen gas is produced. However, if the battery is overcharged, hydrogen gas may be produced. Therefore, be sure there are no fire or spark sources (e.g., short circuit) nearby when charging the battery.
- Be sure to recharge the battery in a well-ventilated and open area.
- Note that the charging system for the MF battery is different from that of a conventional battery. Do not replace the MF battery with a conventional battery.

## CONNECTING THE BATTERY

- When disconnecting terminals from the battery for disassembly or servicing, be sure to disconnect the  $\ominus$  battery lead wire, first.
- When connecting the battery lead wires, be sure to connect the  $\oplus$  battery lead wire, first.
- If the terminal is corroded, remove the battery, pour warm water over it and clean it with a wire brush.
- After connecting the battery, apply a light coat of grease to the battery terminals.
- Install the cover over the  $\oplus$  battery terminal.

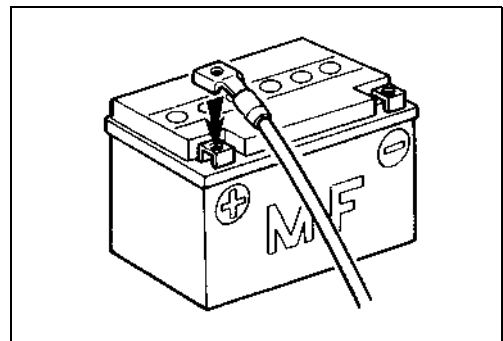
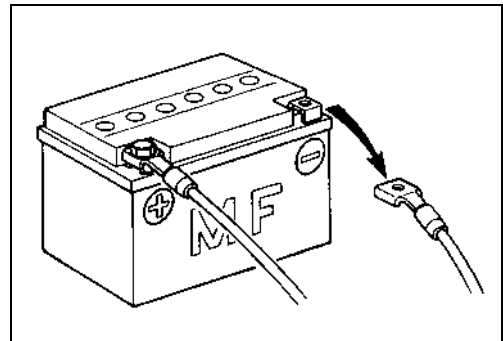

## WIRING PROCEDURE

- Properly route the wire harness according to the "WIRING HARNESS ROUTING" section. (☞ 11-35 to -37)

## USING THE MULTI-CIRCUIT TESTER

- Properly use the multi-circuit tester  $\oplus$  and  $\ominus$  probes. Improper use can cause damage to the motorcycle and tester.
- If the voltage and current values are not known, begin measuring in the highest range.
- When measuring the resistance, make sure that no voltage is applied. If voltage is applied, the tester will be damaged.
- After using the tester, be sure to turn the switch to the OFF position.

 **09900-25008: Multi-circuit tester set**

### CAUTION

**Before using the multi-circuit tester, read its instruction manual.**

### NOTE:

- \* *When connecting the multi-circuit tester, use the needle pointed probe to the back side of the lead wire coupler and connect the probes of tester to them.*
- \* *Use the needle pointed probe to prevent the rubber of the water proof coupler from damage.*

 **09900-25009: Needle pointed probe set**

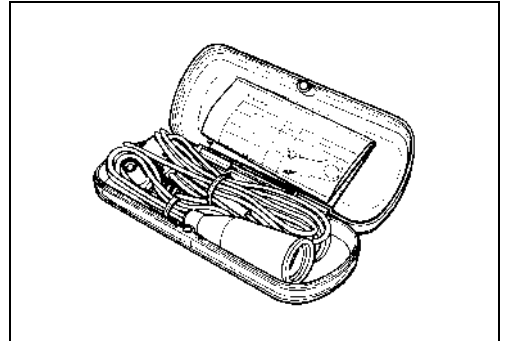
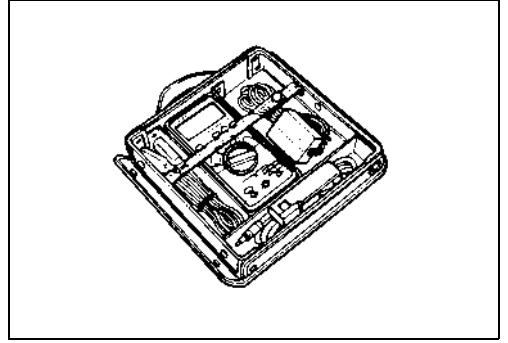

## LOCATION OF ELECTRICAL COMPONENTS

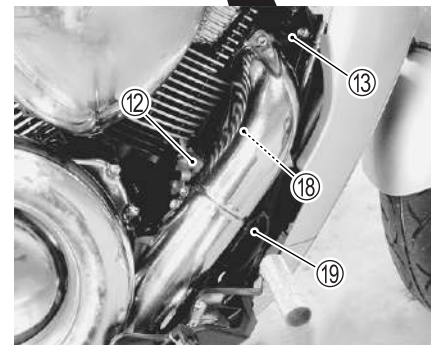
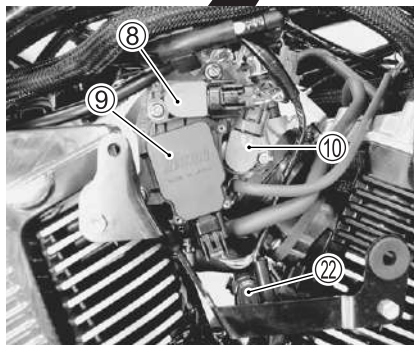
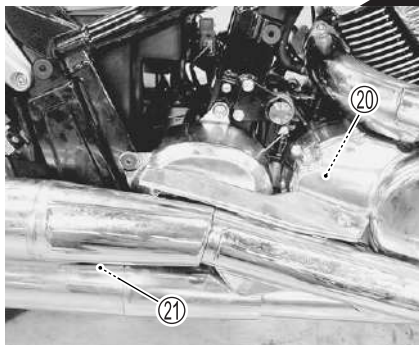
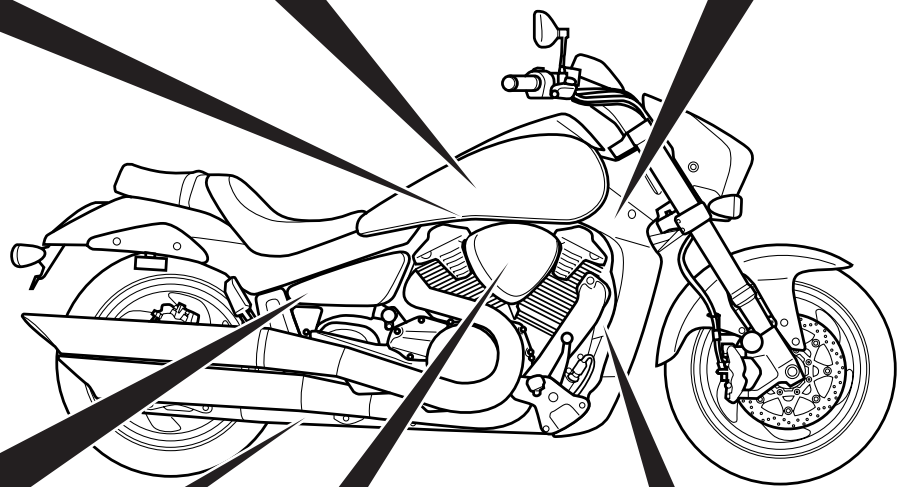
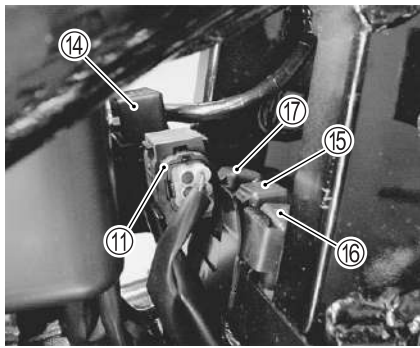
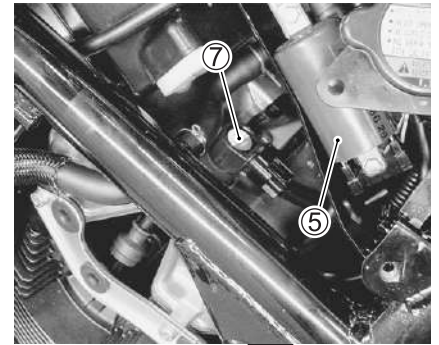
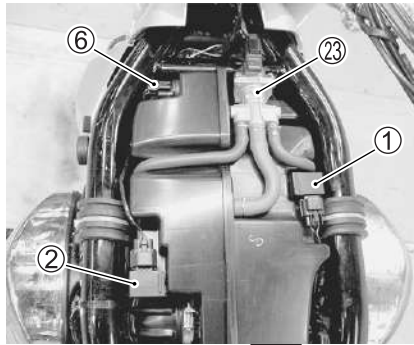
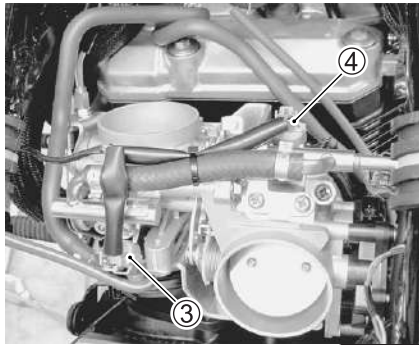

- ① IAP sensor (#2) (☞ 5-34)
- ② IAP sensor (#1) (☞ 5-34)
- ③ Fuel injector (#1) (☞ 5-68)
- ④ Fuel injector (#2) (☞ 5-68)
- ⑤ Ignition coil (#1)
- ⑥ IAT sensor (☞ 5-50)
- ⑦ Ignition coil/Plug cap (#2)
- ⑧ STP sensor (☞ 5-61)
- ⑨ STV actuator (☞ 5-58)
- ⑩ TP sensor (☞ 5-41)
- ⑪ TO sensor (☞ 5-54)
- ⑫ Starter motor

- ⑬ Horn
- ⑭ Turn signal/Side-stand relay
- ⑮ Fuel pump relay (☞ 6-6)
- ⑯ Headlight relay
- ⑰ Cooling fan relay (☞ 8-8)
- ⑱ Cooling fan (☞ 8-8)
- ⑲ Rear brake switch
- ⑳ GP switch (☞ 5-66)
- ㉑ EXCV actuator (☞ 5-83)
- ㉒ ECT sensor (☞ 5-46)
- ㉓ ISC valve (☞ 5-70)

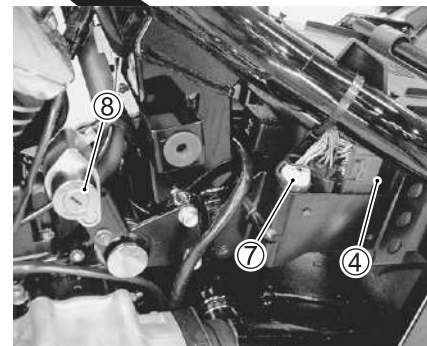
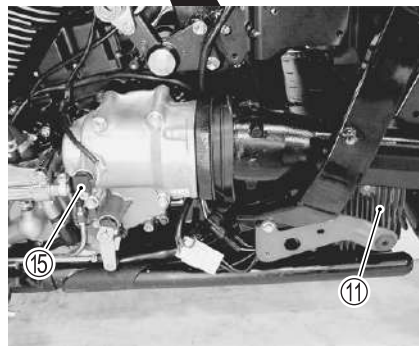
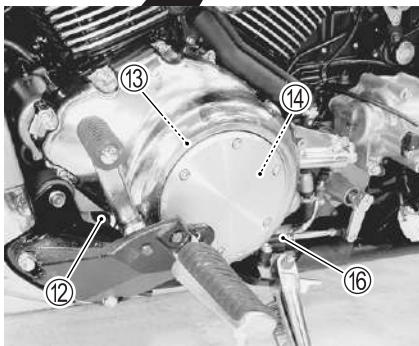
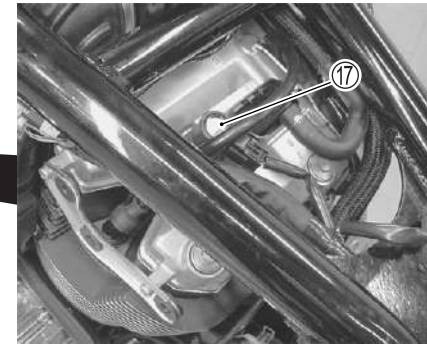
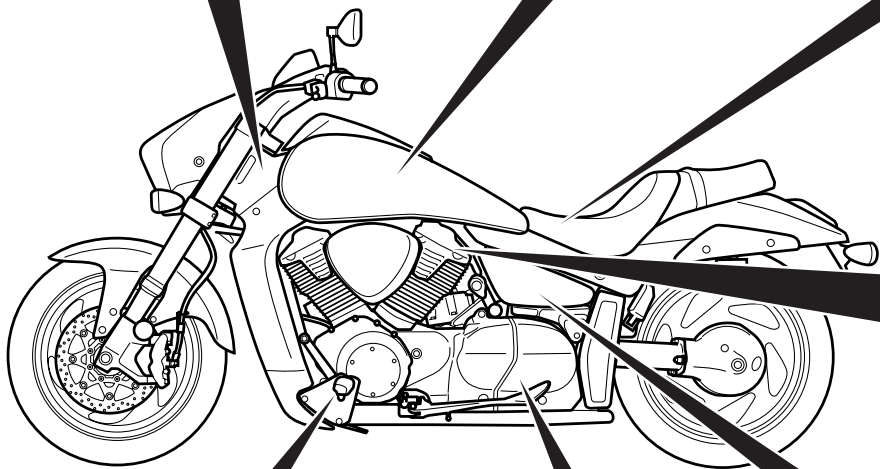
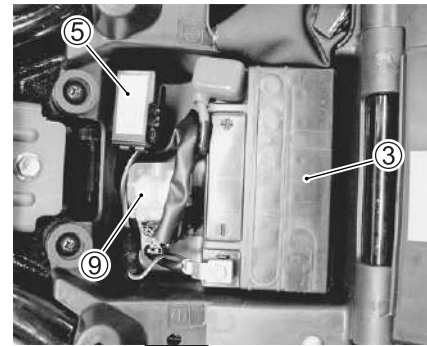
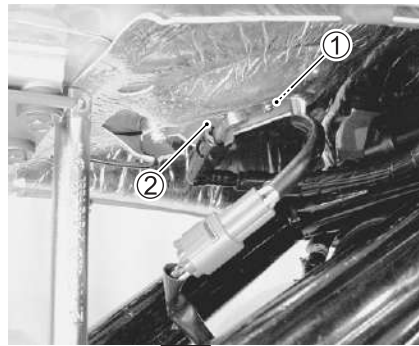
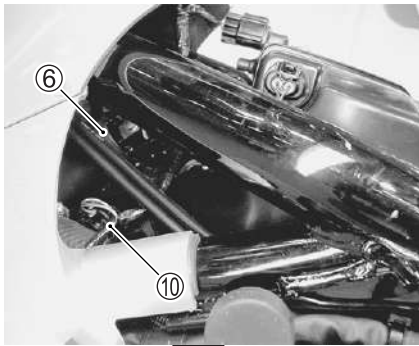

- |  |  |
|--|--|
| ① Fuel level gauge                       | ⑩ PAIR control solenoid valve (☞ 12-6) |
| ② Fuel pump (☞ 6-8)                      | ⑪ Regulator/Rectifier                  |
| ③ Battery                                | ⑫ Oil pressure switch                  |
| ④ ECM (Engine Control Module)            | ⑬ Generator                            |
| ⑤ Fuse box                               | ⑭ CKP sensor (☞ 5-32)                  |
| ⑥ Ignition coil (#2)                     | ⑮ Speedometer sensor                   |
| ⑦ Mode selection switch coupler (☞ 5-24) | ⑯ Side-stand switch                    |
| ⑧ Ignition switch                        | ⑰ Ignition coil/Plug cap (#1)          |
| ⑨ Starter relay/Main fuse                |  |

## CHARGING SYSTEM

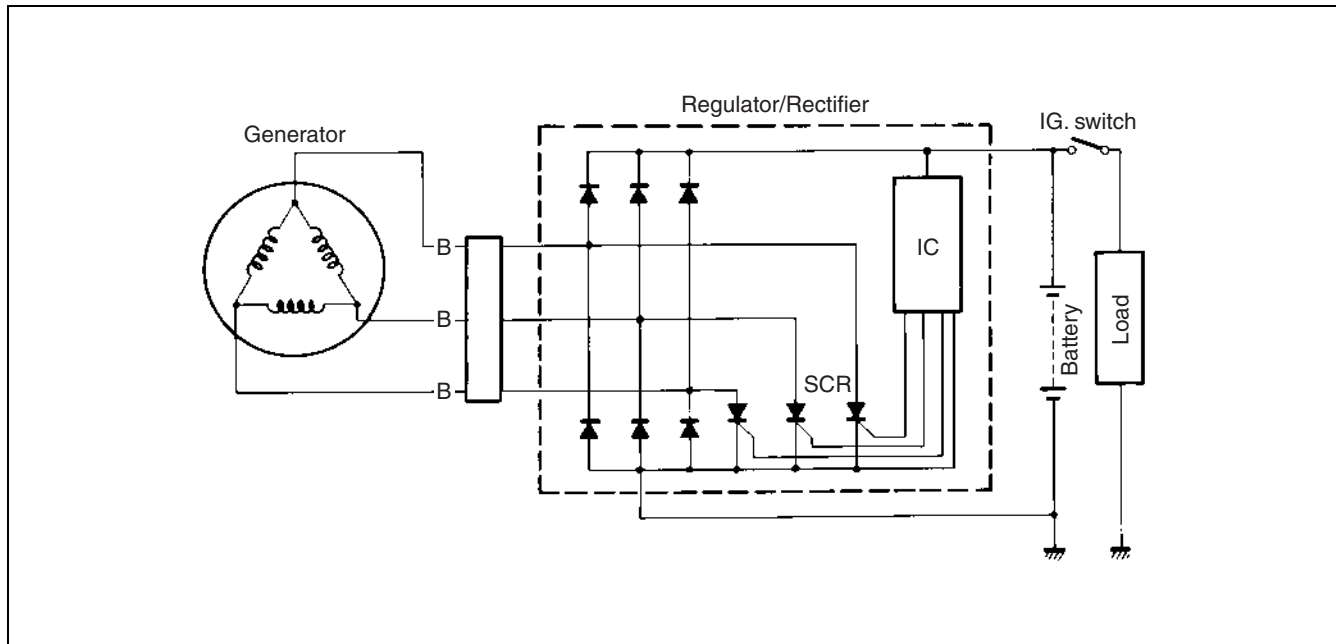

## TROUBLESHOOTING

### Battery runs down quickly

#### Step 1

1) Check accessories which use excessive amounts of electricity.

Are accessories being installed?

YES	Remove accessories.
NO	Go to Step 2.

#### Step 2

1) Check the battery for current leaks. (☞ 10-9)

Is the battery for current leaks OK?

YES	Go to Step 3.
NO	<ul style="list-style-type: none"> <li>• Short circuit of wire harness</li> <li>• Faulty electrical equipment</li> </ul>

#### Step 3

1) Measure the regulated voltage between the battery terminals. (☞ 10-10)

Is the regulated voltage OK?

YES	<ul style="list-style-type: none"> <li>• Faulty battery</li> <li>• Abnormal driving condition</li> </ul>
NO	Go to Step 4.

#### Step 4

1) Measure the resistance of the generator coil. (☞ 10-10)

Is the resistance of generator coil OK?

YES	Go to Step 5.
NO	<ul style="list-style-type: none"> <li>• Faulty generator coil</li> <li>• Disconnected lead wires</li> </ul>



**Step 5**

- 1) Measure the generator no-load performance. (👉 10-11)  
Is the generator no-load performance OK?

YES	Go to Step 6.
NO	Faulty generator

**Step 6**

- 1) Inspect the regulator/rectifier. (👉 10-11)  
Is the regulator/rectifier OK?

YES	Go to Step 7.
NO	Faulty regulator/rectifier

**Step 7**

- 1) Inspect wirings.  
Is the wirings OK?

YES	Faulty battery
NO	<ul style="list-style-type: none"> <li>• Short circuit of wire harness</li> <li>• Poor contact of couplers</li> </ul>

**Battery overcharges**

- Faulty regulator/rectifier
- Faulty battery
- Poor contact of generator lead wire coupler

**INSPECTION****BATTERY CURRENT LEAKAGE**

- Remove the front seat. (👉 9-4)
- Turn the ignition switch to the OFF position.
- Remove the battery cover.
- Disconnect the battery  $\ominus$  lead wire.
- Measure the current between  $\ominus$  battery terminal and the  $\ominus$  battery lead wire using the multi-circuit tester. If the reading exceeds the specified value, leakage is evident.

 **09900-25008: Multi-circuit tester set**

 **Battery current (leak): Under 3 mA**

 **Tester knob indication: Current (---, 20 mA)**

**CAUTION**

- \* In case of a large current leak, turn the tester to high range first to avoid tester damage.
- \* Do not turn the ignition switch to the "ON" position when measuring current.

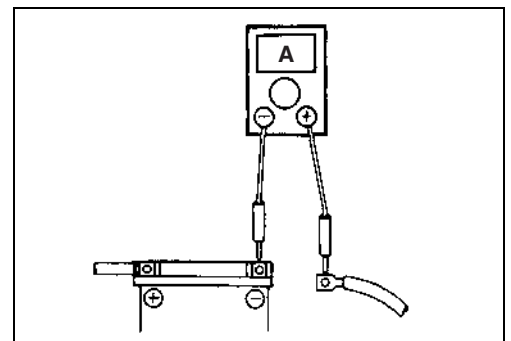
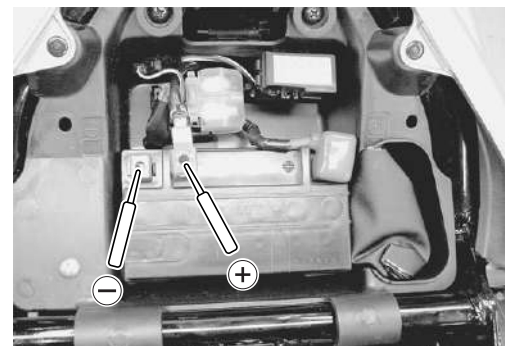



**REGULATED VOLTAGE**

- Remove the front seat. (☞ 9-4)
- Start the engine and keep it running at 5 000 r/min with the dimmer switch turned HI position.
- Measure the DC voltage between the ⊕ and ⊖ battery terminals using the multi-circuit tester. If the voltage is not within the specified value, inspect the generator and regulator/rectifier. (☞ 10-10 and -11)

**NOTE:**

When making this test, be sure that the battery is in fully-charged condition.

**TOOL** 09900-25008: Multi-circuit tester set

**Tester knob indication: Voltage (V)**

**DATA** Regulated voltage (Charging output):  
14.0 – 15.5 V at 5 000 r/min

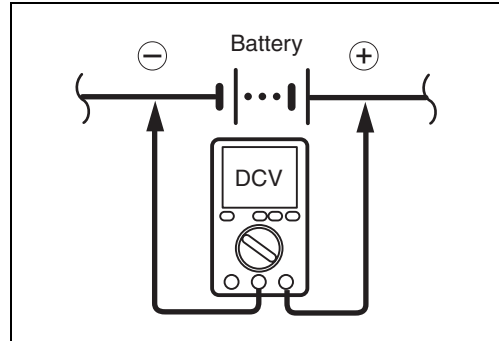
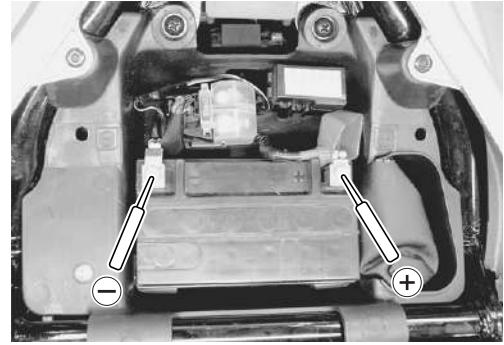

**GENERATOR COIL RESISTANCE**

- Remove the fuel tank. (☞ 6-3)
- Remove the left frame side cover. (☞ 9-5)
- Remove the left frame lower side cover. (☞ 3-6)
- Disconnect the generator coupler ①.
- Measure the resistance between the three lead wires.  
If the resistance is out of specified value, replace the stator with a new one. Also, check that the generator core is insulated properly.

**TOOL** 09900-25008: Multi-circuit tester set

**Tester knob indication: Resistance (Ω)**

**DATA** Generator coil resistance: 0.2 – 1.5 Ω (Black – Black)  
∞ Ω (Black – Ground)

**NOTE:**

When making above test, it is not necessary to remove the generator.

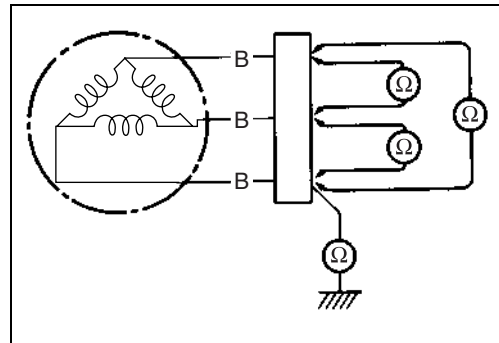
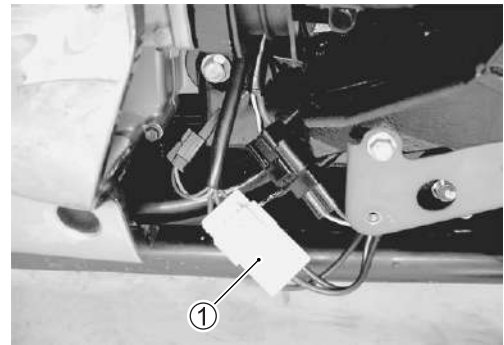

**GENERATOR NO-LOAD PERFORMANCE**

- Disconnect the generator coupler. (☞ 10-10)
- Start the engine and keep it running at 5 000 r/min.
- Using the multi-circuit tester, measure the voltage between three lead wires.

If the tester reads under the specified value, replace the generator with a new one.

**TOOL** 09900-25008: Multi-circuit tester set

**V** Tester knob indication: Voltage (~)

**DATA** Generator no-load performance:  
70 V (AC) and more at 5 000 r/min  
(When engine is cold)

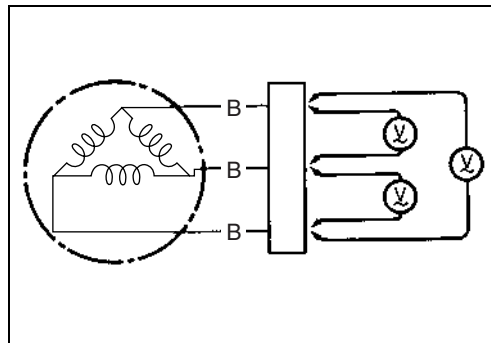
**REGULATOR/RECTIFIER**

- Remove the fuel tank. (☞ 6-3)
- Remove the left frame side cover. (☞ 9-5)
- Remove the left frame lower side cover. (☞ 3-6)
- Disconnect the regulator/rectifier couplers ①.
- Measure the voltage between the lead wires using the multi-circuit tester as indicated in the table below. If the voltage is not within the specified value, replace the regulator/rectifier with a new one. (☞ 9-41)

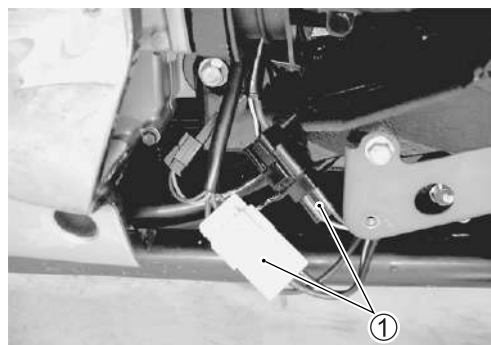

**TOOL** 09900-25008: Multi-circuit tester set

**D** Tester knob indication: Diode test (→←)

Unit: V

		⊕ Probe of tester to:				
		B/R	B/W	B <sub>1</sub>	B <sub>2</sub>	B <sub>3</sub>
① Probe of tester to:	B/R		0.5 – 1.2	0.4 – 0.7	0.4 – 0.7	0.4 – 0.7
	B/W	*		*	*	*
	B <sub>1</sub>	*	0.4 – 0.7		*	*
	B <sub>2</sub>	*	0.4 – 0.7	*		*
	B <sub>3</sub>	*	0.4 – 0.7	*	*	

\*1.4 V and more (tester's battery voltage)

**NOTE:**

If the tester reads 1.4 V and below when the tester probes are not connected, replace its battery.

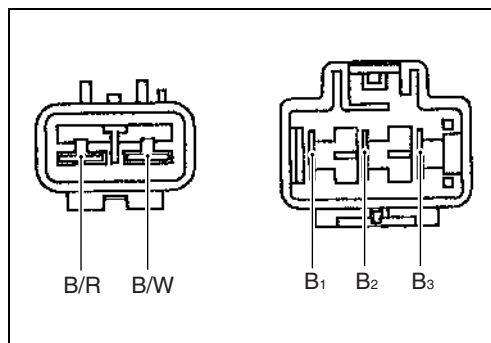

## STARTER SYSTEM AND SIDE-STAND/IGNITION INTERLOCK SYSTEM

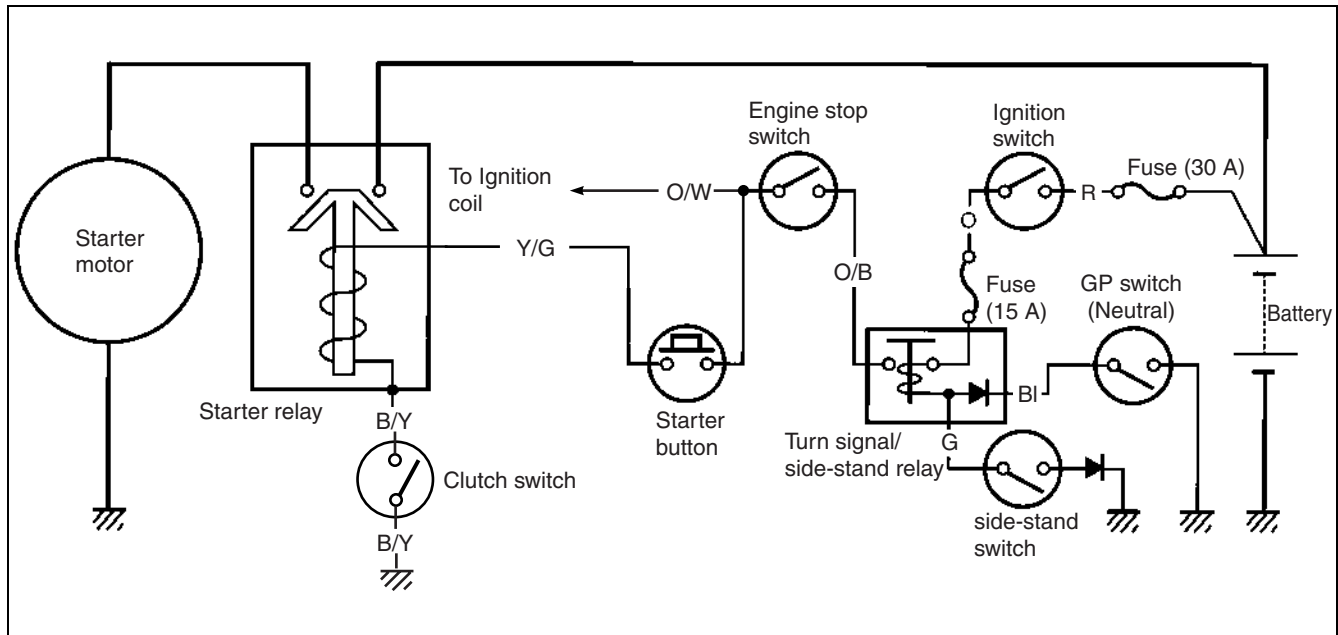

### TROUBLESHOOTING

Make sure that the fuses are not blown and the battery is fully-charged before diagnosing.

#### Starter motor will not run

##### Step 1

- 1) Shift the transmission to neutral.
- 2) Pull the clutch lever, turn on the ignition switch with the engine stop switch in the "RUN" position and listen for a click from the starter relay when the starter button is pushed.

Is a click sound heard?

YES	Go to Step 2.
NO	Go to Step 3.

##### Step 2

- 1) Check if the starter motor runs when its terminal is connected to the battery ⊕ terminal. (Do not use thin "wire" because a large amount of current flows.)

Does the starter motor run?

YES	<ul style="list-style-type: none"> <li>• Faulty starter relay</li> <li>• Loose or disconnected starter motor lead wire</li> <li>• Loose or disconnected between starter relay and battery ⊕ terminal</li> </ul>
NO	Faulty starter motor

**Step 3**

1) Measure the starter relay voltage at the starter relay connectors (between Y/G ⊕ and B/Y ⊖) when the starter button is pushed.

Is a voltage OK?

YES	Go to Step 4.
NO	<ul style="list-style-type: none"> <li>• Faulty engine stop switch</li> <li>• Faulty clutch switch</li> <li>• Faulty GP switch</li> <li>• Faulty turn signal/side-stand relay</li> <li>• Faulty starter button</li> <li>• Faulty ignition switch</li> <li>• Faulty side-stand switch</li> <li>• Poor contact of connector</li> <li>• Open circuit in wire harness</li> </ul>

**Step 4**

1) Check the starter relay. (🔧 10-18)

Is the starter relay OK?

YES	Poor contact of the starter relay
NO	Faulty starter relay

**Starter motor runs but does not crank the engine****Step 1**

1) The starter motor runs when the transmission is in neutral, but does not run when the transmission is in any position other than neutral, with the side-stand up.

2) Check the side-stand switch. (🔧 10-19)

Is the side-stand switch OK?

YES	Go to Step 2.
NO	Faulty side-stand switch

**Step 2**

1) Check the starter clutch.

Is the starter clutch OK?

YES	Faulty starter clutch
NO	<ul style="list-style-type: none"> <li>• Open circuit in wire harness</li> <li>• Poor contact of connector</li> </ul>

## STARTER MOTOR REMOVAL

- Remove the right frame side cover. (👉 9-5)
- Remove the exhaust pipe and muffler. (👉 7-8)
- Remove the master cylinder cover ①.

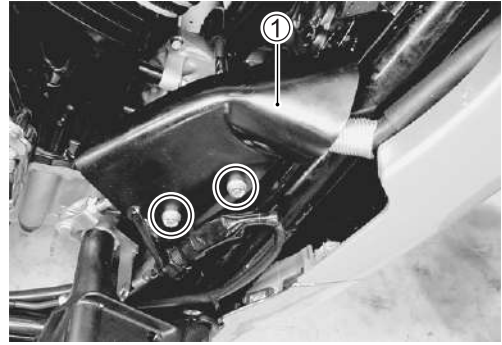

- Disconnect the battery ⊖ lead wire.
- Disconnect the starter motor lead wire ②.
- Remove the starter motor ③.

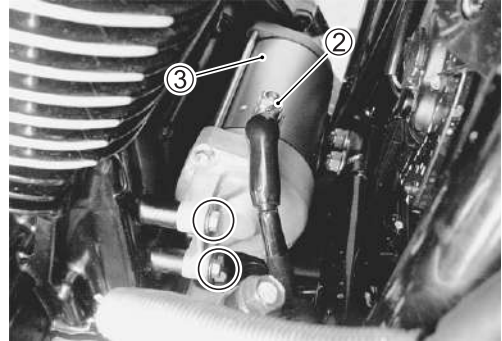

## STARTER MOTOR DISASSEMBLY

- Disassemble the starter motor as shown in the illustration.

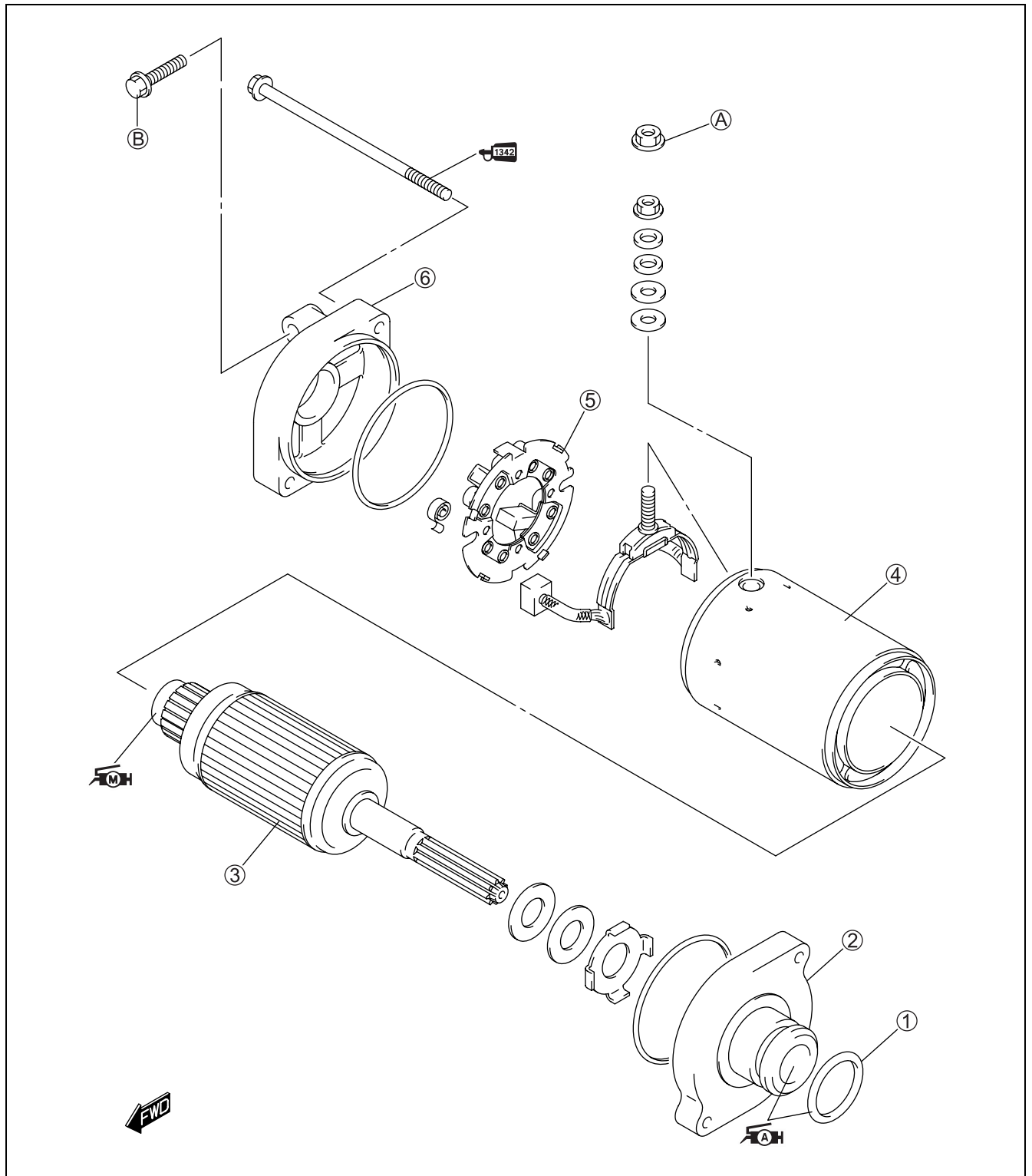

①	O-ring	⑤	Brush holder
②	Housing end (inside)	⑥	Housing end (outside)
③	Armature	A	Starter motor lead wire nut
④	Starter motor case	B	Starter motor mounting bolt



ITEM	N·m	kgf·m	lb·ft
A	6	0.6	4.5
B	6	0.6	4.5



## STARTER MOTOR INSPECTION

### CARBON BRUSH

Inspect the brushes for abnormal wear, cracks, or smoothness in the brush holder.

If any damages are found, replace the brush assembly with a new one.

Make sure that the length  $\textcircled{A}$  is not less than 6.0 mm (0.24 in). If this length becomes less than 6.0 mm (0.24 in), replace the brush.

#### **DATA** Starter motor brush length

**Service limit: 6.0 mm (0.24 in)**

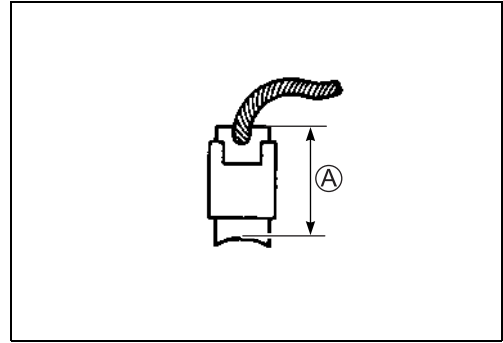

### COMMUTATOR

Inspect the commutator for discoloration, abnormal wear or undercut  $\textcircled{A}$ .

If abnormal wear is found, replace the armature with a new one.

If the commutator surface is discolored, polish it with #400 sand paper and wipe it using a clean dry cloth.

If there is no undercut, scrape out the insulator with a saw blade.

① Insulator

② Segment

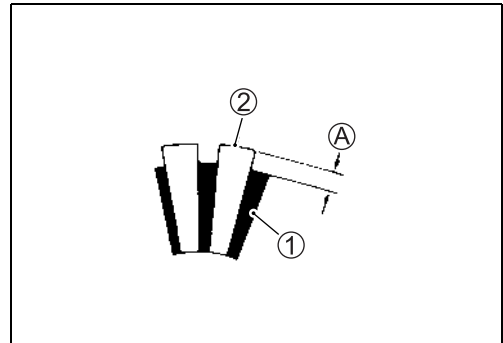

### ARMATURE COIL INSPECTION

Check for continuity between each segment and between each segment and the armature shaft using the multi-circuit tester.

If there is no continuity between the segments or there is continuity between the segments and shaft, replace the armature with a new one.

#### **TOOL** 09900-25008: Multi-circuit tester set

**Tester knob indication: Continuity test (•))**

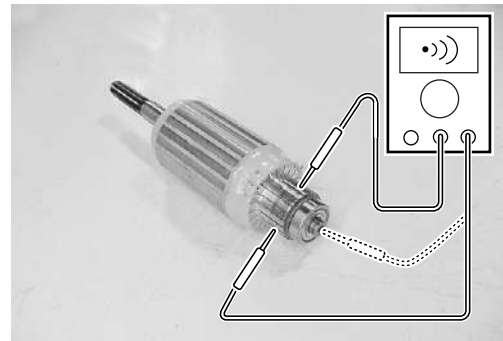

### BEARING INSPECTION

- Inspect the armature shaft bearing for abnormal noise and smooth rotation.
- Replace the armature assembly if there is anything unusual.



## HOUSING END INSPECTION

- Inspect the bearing for abnormal noise and smooth rotation.
- Check the oil seal lip for damage or leakage.  
If any damage is found, replace the housing end.



## STARTER MOTOR REASSEMBLY

Reassemble the starter motor in the reverse order of disassembly. Pay attention to the following points:

- Apply SUZUKI SUPER GREASE "A" to the lip of the oil seal and bearing.

 **99000-25010: SUZUKI SUPER GREASE "A" or equivalent**



- Align the projection ① on the brush holder with the groove ② on the starter motor case.

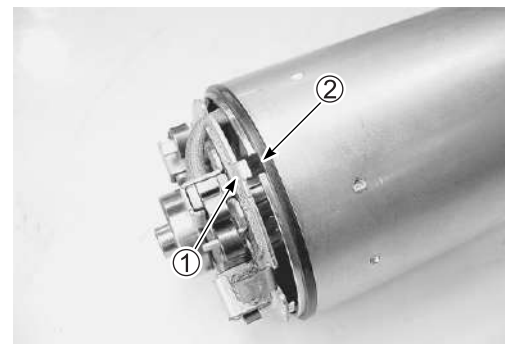

- Tighten the brush holder nut to the specified torque.

 **Brush holder nut: 10 N·m (1.0 kgf-m, 7.0 lb-ft)**

- Align the projection ③ on the brush holder with the groove ④ on the housing end.

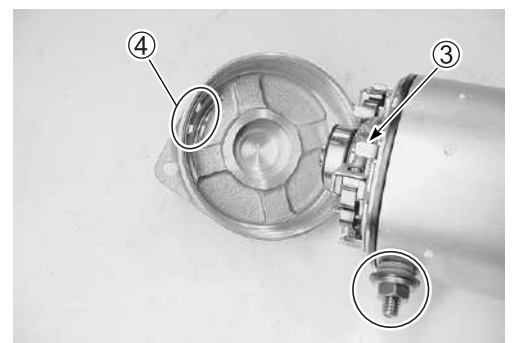

- Align the line on the starter motor case with the line (A) on the housing end.
- Apply a small quantity of THREAD LOCK to the starter motor housing bolts.

 **99000-32050: THREAD LOCK "1342" or equivalent**

- Apply SUZUKI SUPER GREASE "A" to the O-ring.

 **99000-25010: SUZUKI SUPER GREASE "A" or equivalent**

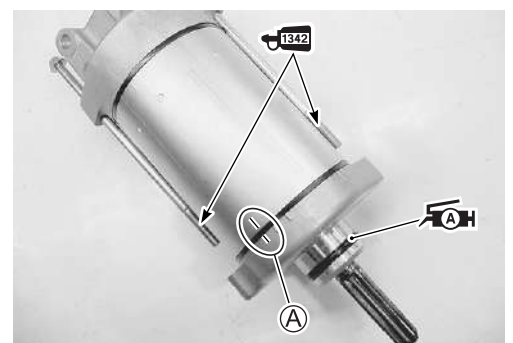

- Tighten the starter motor mounting lead wire bolts ⑤ and nut ⑥ to the specified torque.

**🔧 Starter motor mounting bolt: 6 N·m (0.6 kgf-m, 4.5 lb-ft)**  
**🔧 Starter motor lead wire nut: 6 N·m (0.6 kgf-m, 4.5 lb-ft)**

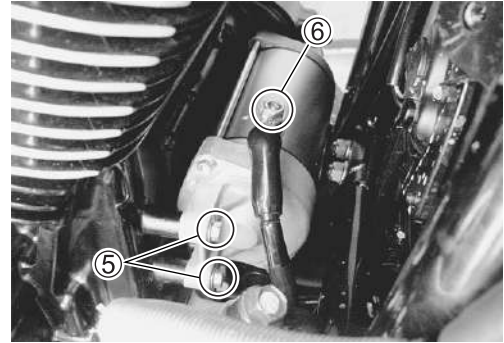

## STARTER RELAY INSPECTION

- Remove the front seat. (👉 9-4)
- Remove the battery cover.
- Disconnect the battery ⊖ lead wire from the battery.
- Remove the starter relay cover ①.
- Disconnect the starter relay coupler ②, starter motor lead wire ③ and battery lead wire ④.
- Remove the starter relay.
- Apply 12 V to Ⓐ and Ⓑ terminals and check for continuity between the positive and negative terminals using the multi-circuit tester. If the starter relay clicks and continuity is found, the relay is ok.

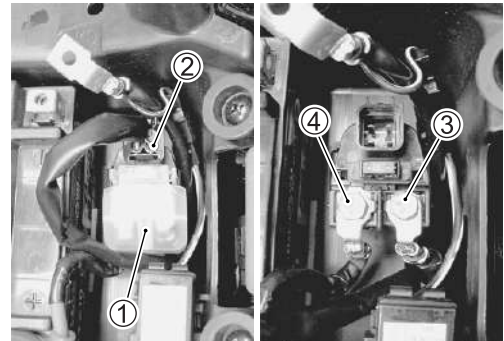

**🔧 09900-25008: Multi-circuit tester set**

**🔧 Tester knob indication: Continuity test (•••)**

### CAUTION

**Do not apply battery voltage to the starter relay for more than five seconds, since the relay coil may over-heat and get damaged.**

Measure the relay coil resistance between the terminals using the multi-circuit tester. If the resistance is not within the specified value, replace the starter relay with a new one.

**🔧 09900-25008: Multi-circuit tester set**

**📊 Starter relay resistance: 3 – 6 Ω**

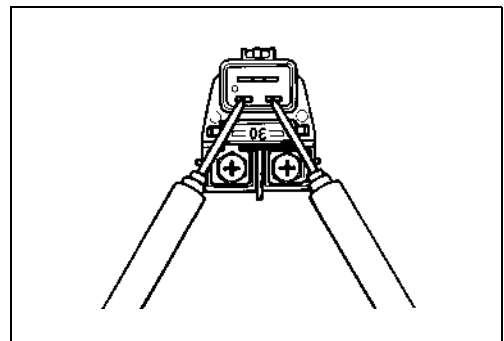
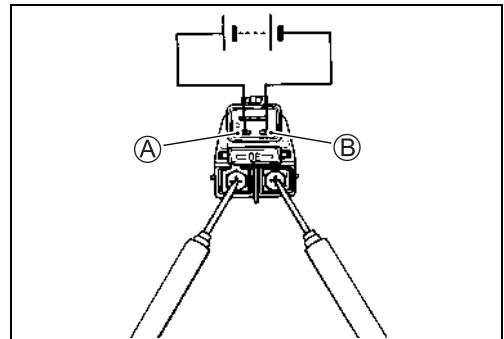

## SIDE STAND/IGNITION INTERLOCK SYSTEM PARTS INSPECTION

Check the interlock system for proper operation. If the interlock system does not operate properly, check each component for damage or abnormalities. If any abnormality is found, replace the component with a new one.

### SIDE-STAND SWITCH

- Remove the left frame side cover. (☞ 9-5)
- Disconnect the side-stand switch coupler and measure the voltage between Green and Black/White lead wires.

 **09900-25008: Multi-circuit tester set**

 **Tester knob indication: Diode test (⇄)**

	Green (⊕ Probe)	Black/White (⊖ Probe)
ON (Side-stand up)	0.4 – 0.6 V	
OFF (Side-stand down)	1.4 V and more (Tester's battery voltage)	

#### NOTE:

*If the tester reads 1.4 V and below when the tester probes are not connected, replace its battery.*



**GEAR POSITION SWITCH**

- Remove the right frame side cover. (☞ 9-5)
- Disconnect the gear position switch coupler and check the continuity between Blue and Black/White with the transmission in “NEUTRAL”.

**TOOL** 09900-25008: Multi-circuit tester set

**Tester knob indication: Continuity test (••)**

	Blue	Black/White
ON (Neutral)	○ — ○	○ — ○
OFF (Except neutral)		

**CAUTION**

When disconnecting and connecting the gear position switch coupler, make sure to turn OFF the ignition switch, or electronic parts may get damaged.

- Connect the gear position switch coupler to the wiring harness.
- Turn the ignition switch to “ON” position and side-stand to upright position.
- Measure the voltage between Pink and Black/White lead wires using the multi-circuit tester when shifting the gearshift lever from low to top.

**TOOL** 09900-25008: Multi-circuit tester set

09900-25009: Needle pointed probe set

**Tester knob indication: Voltage (—V—)**

**DATA** Gear position switch voltage: 0.6 V and more

\* Low to top gear position (Pink ⊕ – B/W ⊖)

\* Except neutral position (Pink ⊕ – B/W ⊖)

**CAUTION**

Use the special tool, to prevent the rubber of the water proof coupler from damage.

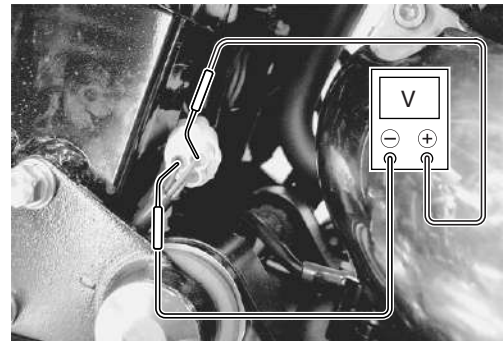
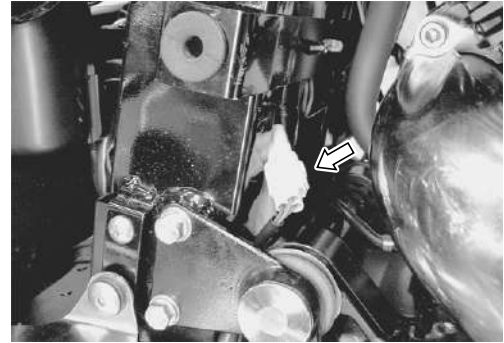

### TURN SIGNAL/SIDE-STAND RELAY

The turn signal/side-stand relay is composed of the turn signal relay, side-stand relay and diode.

- Remove the left frame side cover. (👉 9-5)
- Remove the turn signal/side-stand relay.

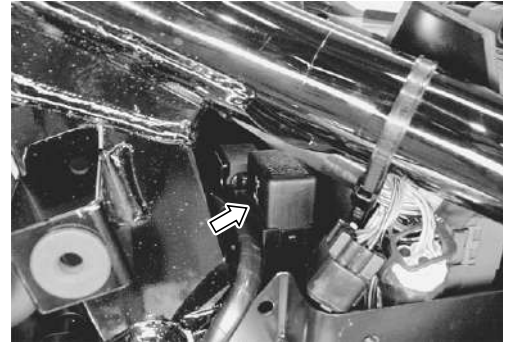

### SIDE-STAND RELAY INSPECTION

First check the insulation between ④ and ⑤ terminals with the tester. Then apply 12 V to terminals ④ and ③ (+ to ④ and - to ③) and check the continuity between ④ and ⑤. If there is no continuity, replace the turn signal/side-stand relay with a new one.

**TOOL** 09900-25008: Multi-circuit tester set

**Tester knob indication: Continuity test (••••)**

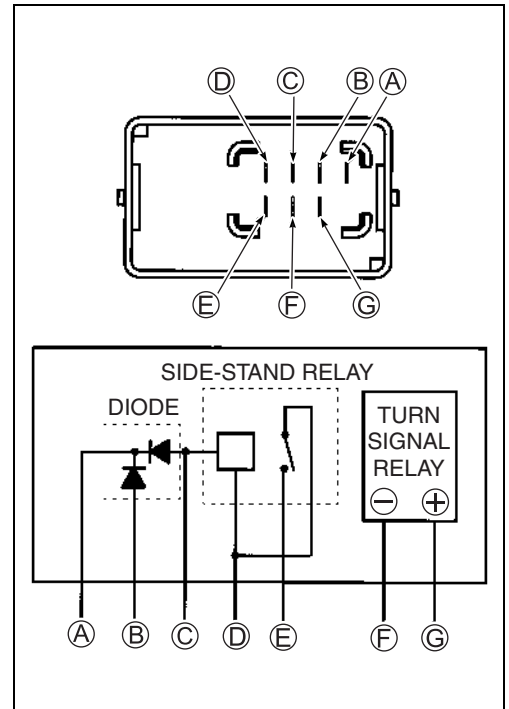

### DIODE INSPECTION

Measure the voltage between the terminals using the multi-circuit tester. Refer to the following table.

- Probe of tester to:	+ Probe of tester to:	
	③, ②	①
③, ②		1.4 V and more (Tester's battery voltage)
①	0.4 - 0.6 V	

**TOOL** 09900-25008: Multi-circuit tester set

**Tester knob indication: Diode test (→←)**

#### NOTE:

If the multi-circuit tester reads 1.4 V and below when the tester probes are not connected, replace its battery.

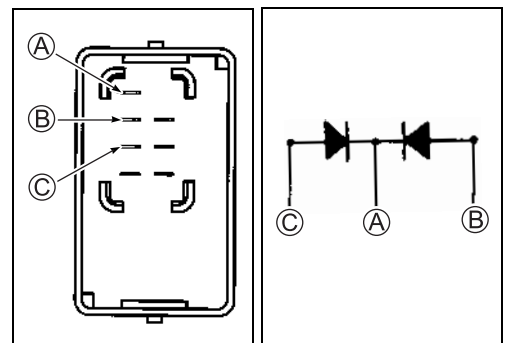



## IGNITION SYSTEM

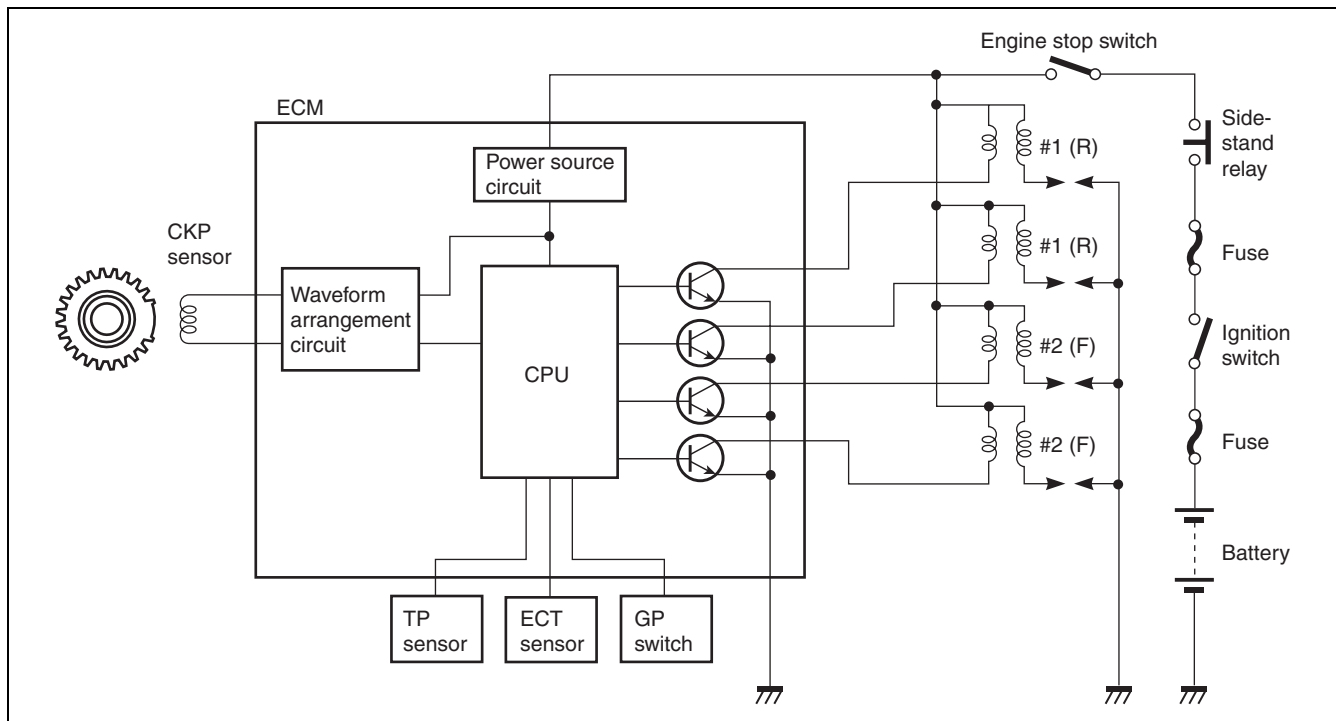

### NOTE:

The fuel cut-off circuit is incorporated in this ECM in order to prevent over-running of engine. When engine speed reaches 7 200 r/min, this circuit cuts off fuel at the fuel injector. But under no load, the clutch lever is pulled or the gear position is neutral, this circuit cuts off fuel when engine speed reaches 7 100 r/min.

### CAUTION

**Under no load, the engine can run over 7 100 r/min though the fuel cut-off circuit is effective, which may possibly cause engine damage. Do not run the engine without load over 7 100 r/min at anytime.**

## TROUBLESHOOTING

### No spark or poor spark

#### NOTE:

Check that the transmission is in neutral and the engine stop switch is in the "RUN" position. Grasp the clutch lever. Check that the fuse is not blown and the battery is fully-charged before diagnosing.

#### Step 1

1) Check the ignition system couplers for poor connections.

Is there connection in the ignition system couplers?

YES	Go to Step 2.
NO	Poor connection of couplers

#### Step 2

1) Measure the battery voltage between input lead wires at the ECM with the ignition switch in the "ON" position. (E-02, 19, 24: O/G and B/W, E-03, 28, 33: O/W and B/W)

Is the voltage OK?

YES	Go to Step 3.
NO	<ul style="list-style-type: none"> <li>• Faulty ignition switch</li> <li>• Faulty turn signal/side-stand relay</li> <li>• Faulty engine stop switch</li> <li>• Broken wire harness or poor connection of related circuit couplers</li> </ul>

#### Step 3

1) Measure the ignition coil primary peak voltage. (☞ 10-25 to -27)

#### NOTE:

This inspection method is applicable only with the multi-circuit tester and the peak volt adaptor.

Is the peak voltage OK?

YES	Go to Step 4.
NO	Go to Step 5.

#### Step 4

1) Inspect the spark plugs. (☞ 2-13 to -16)

Is the spark plug OK?

YES	Go to Step 5.
NO	Faulty spark plug(-s).

**Step 5**

1) Inspect the ignition coil/plug caps and ignition coils. (☞ 10-27 and -28)

Is the ignition coil/plug cap and ignition coils OK?

YES	Go to Step 6.
NO	<ul style="list-style-type: none"><li>• Poor connection of the ignition coil/plug cap(-s) and ignition coils.</li><li>• Faulty ignition coil/plug cap(-s) and ignition coils.</li></ul>

**Step 6**

1) Measure the crankshaft position sensor peak voltage and its resistance. (☞ 10-28 to -29)

**NOTE:**

*The crankshaft position sensor peak voltage inspection is applicable only with the multi-circuit tester and peak volt adaptor.*

Is the peak voltage and resistance OK?

YES	<ul style="list-style-type: none"><li>• Faulty ECM</li><li>• Open or short circuit in wire harness</li><li>• Poor connection of ignition couplers</li></ul>
NO	<ul style="list-style-type: none"><li>• Faulty CKP sensor</li><li>• Metal particles or foreign material being stuck on the CKP sensor and rotor tip</li></ul>

## INSPECTION

### IGNITION COIL PRIMARY PEAK VOLTAGE

- Remove the left frame side covers. (☞ 9-5)
- Remove the fuel tank. (☞ 6-3)
- Remove the frame head covers and right radiator covers. (☞ 9-6)
- Remove the front cylinder right head cover cap and rear cylinder left head cover cap. (☞ 2-13 and -14)
- Disconnect all the ignition coil/plug cap lead wire couplers before removing the ignition coil/plug caps.
- Remove the ignition coil/plug caps and disconnect the plug caps.

#### CAUTION

- \* Do not remove the ignition coil/plug cap before disconnecting the lead wire coupler, or the lead wire will be damaged.
- \* Do not pry up the ignition coil/plug cap with a screwdriver or a bar to avoid damage.
- \* Be careful not to drop the ignition coil/plug cap as it may open or short in a circuit.

- Connect the new spark plugs to each ignition coil/plug caps and plug caps.
- Connect all the ignition coil/plug cap lead wire couplers to the ignition coil/plug caps respectively, and ground them on the cylinder head (each spark plug hole).
- Connect new spark plugs to each spark plug cap and ground them to the cylinder head.

#### NOTE:

*Be sure that all couplers and spark plugs are connected properly and the battery used is in fully-charged condition.*

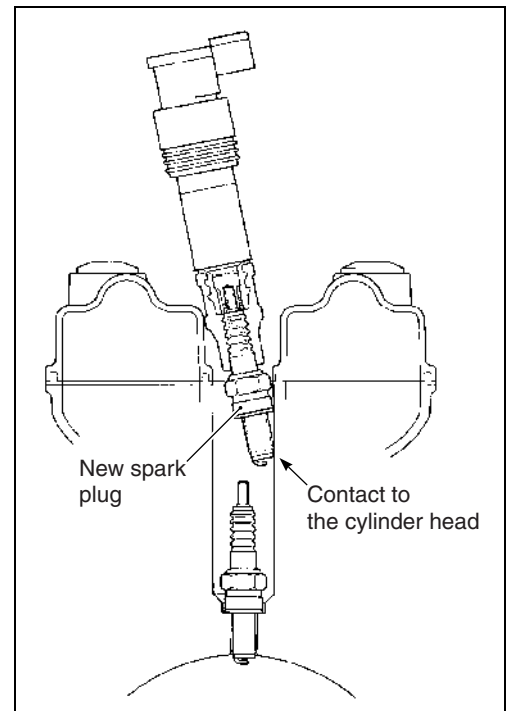
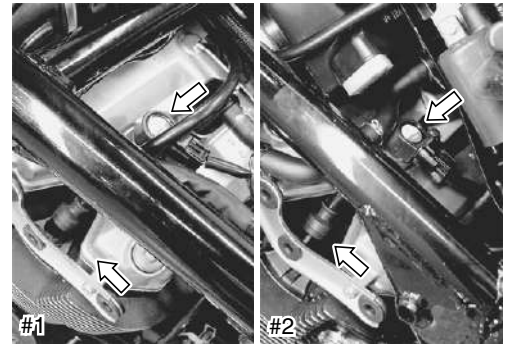

**IGNITION COIL/PLUG CAP PRIMARY PEAK VOLTAGE**

Inspect each ignition coil primary peak voltage at the ignition coil/plug cap coupler.

- Connect the multi-circuit tester with peak voltage adaptor as follows.

#1 ignition coil/plug cap:

W/Bl wire terminal (+ Probe) – Ground (– Probe) terminal

#2 ignition coil/plug cap:

Black wire terminal (+ Probe) – Ground (– Probe) terminal

- TOOL** 09900-25008: Multi-circuit tester set
- 09900-25009: Needle pointed probe set

**CAUTION**

Before using the multi-circuit tester and peak volt adaptor, be sure to refer to the appropriate instruction manual.

**NOTE:**

Use the special tool, to prevent the rubber of the water proof coupler from damage.

- Shift the transmission into neutral and turn ignition switch “ON”.
- Pull the clutch lever.
- Crank the engine a few seconds with the starter motor by depressing starter button and check the ignition coil primary peak voltage.
- Repeat the above inspection a few times and measure the highest peak voltage.

**V** **Tester knob indication: voltage (---)**

**DATA** Ignition coil/plug cap primary peak voltage:  
80 V and more

**⚠ WARNING**

Do not touch the tester probes and spark plugs to prevent an electric shock while testing.

If the peak voltage is lower than the standard range, check the ignition coil/plug cap. (📄 10-27)

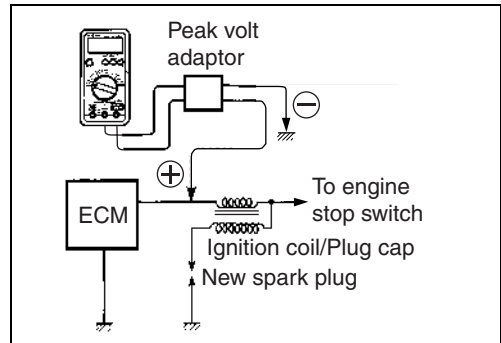
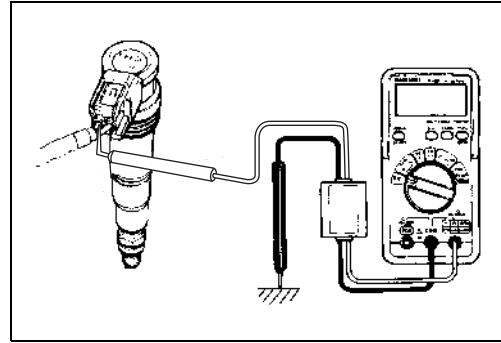

**IGNITION COIL PRIMARY PEAK VOLTAGE**

Inspect each ignition coil primary peak voltage in the following procedure.

- Connect the multi-circuit tester with peak voltage adaptor as follows.
  - #1 ignition coil: ⊕ Probe: Yellow lead wire terminal
  - ⊖ Probe: Ground
  - #2 ignition coil: ⊕ Probe: Green lead wire terminal
  - ⊖ Probe: Ground

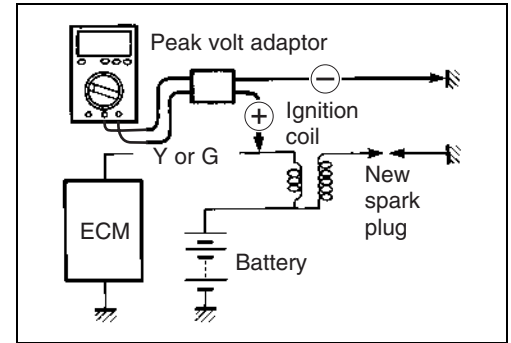
**NOTE:**

Do not disconnect the ignition coil primary wire coupler.

**TOOL** 09900-25008: Multi-circuit tester set

**CAUTION**

Before using the multi-circuit tester and peak volt adaptor, be sure to refer to the appropriate instruction manual.

- Inspect the ignition coil primary peak voltage in the same manner as the ignition coil/plug cap. (☞ 10-26)

**TESTER** Tester knob indication: Voltage (V)

**DATA** Ignition coil primary peak voltage: 250 V and more

If the peak voltage is lower than the specified values, inspect the ignition coil. (☞ 10-28)

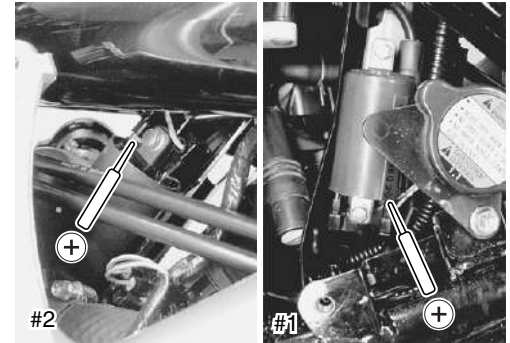
**IGNITION COIL/PLUG CAP RESISTANCE**

- Disconnect the ignition coil/plug cap. (☞ 10-25)
- Check the ignition coil/plug cap for resistance in both primary and secondary coils. If the resistance is not within the standard range, replace the ignition coil/plug cap with a new one.

**TOOL** 09900-25008: Multi-circuit tester set

**TESTER** Tester knob indication: Resistance (Ω)

**DATA** Ignition coil/plug cap resistance

Primary : 1.1 – 1.9 Ω (+ tap – ⊖ tap)

Secondary: 10.8 – 16.2 kΩ (Plug cap – ⊖ tap)

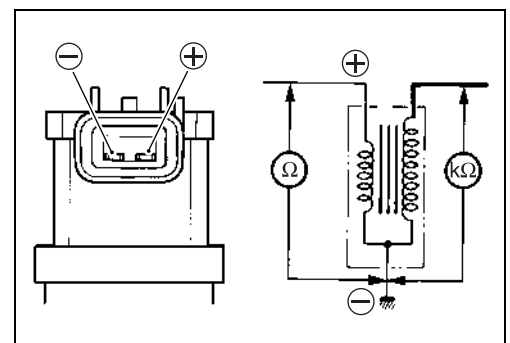
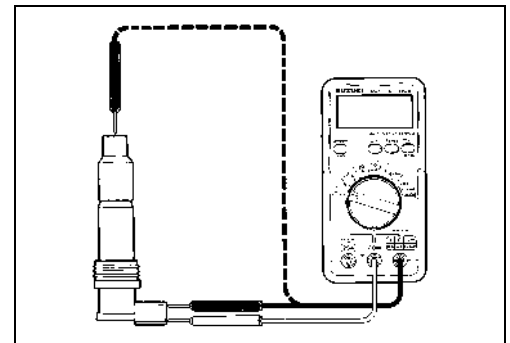



**IGNITION COIL RESISTANCE**

- Disconnect the spark plug caps. (🔧 10-25)
- Measure the ignition coil resistance in both the primary and secondary windings. If the resistance is not within the standard range, replace the ignition coil with a new one.

**TOOL** 09900-25008: Multi-circuit tester set

**Tester knob indication: Resistance ( $\Omega$ )**

**DATA** Ignition coil resistance

- Primary: 1.8 – 3.0  $\Omega$  ( $\oplus$  terminal –  $\ominus$  terminal)**
- Secondary: 16 – 26 k $\Omega$  (Plug cap –  $\ominus$  terminal)**

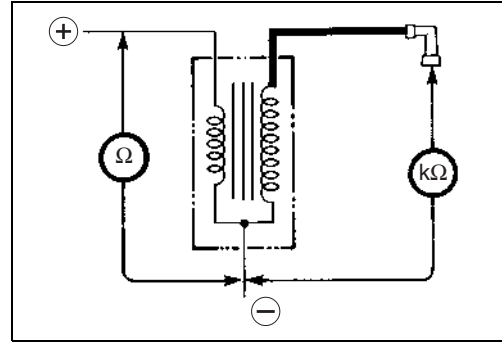

**CKP SENSOR PEAK VOLTAGE**

- Remove the fuel tank. (🔧 6-3)
- Remove the left frame side cover. (🔧 9-5)
- Remove the left frame lower side cover. (🔧 3-6)
- Disconnect the CKP sensor lead wire coupler ① and connect the multi-circuit tester with the peak volt adaptor.

Blue ( $\oplus$  Probe) – Green ( $\ominus$  Probe)

- Measure the CKP sensor peak voltage at the CKP sensor lead wire coupler.

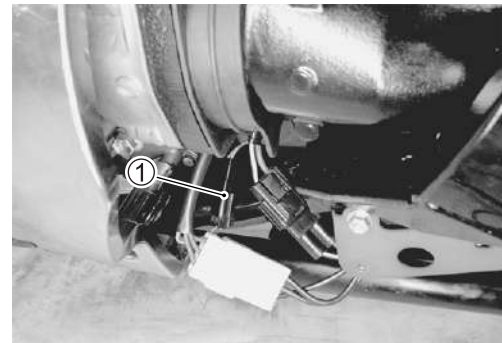

**CAUTION**

**Before using the multi-circuit tester and peak volt adaptor, be sure to refer to the appropriate instruction manual.**

- Shift the transmission into the neutral and turn ignition switch “ON”.
- Crank the engine a few seconds with the starter motor by depressing starter button and check the CKP sensor peak voltage.
- Repeat the above test procedure a few times and measure the highest peak voltage.

**Tester knob indication: Voltage (V)**

**TOOL** 09900-25008: Multi-circuit tester set

**DATA** CKP sensor peak voltage: 1.5 V and more

If the peak voltage is within the specification, check the continuity between the CKP sensor coupler and ECM coupler.

**CAUTION**

**Normally, use the needle pointed probe to the back-side of the lead wire coupler to prevent the terminal bend and terminal alignment.**

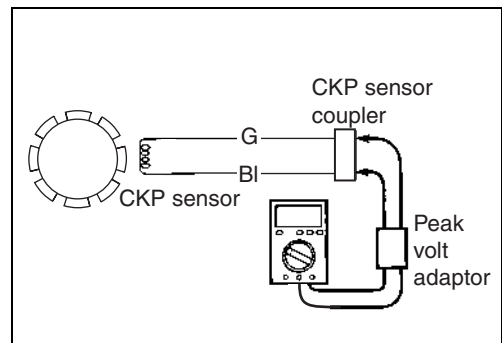

**CKP SENSOR RESISTANCE**

- Measure the resistance between the lead wires and ground. If the resistance is not within the standard range, replace the CKP sensor with a new one.

**TOOL** 09900-25008: Multi-circuit tester set

**TESTER** Tester knob indication: Resistance ( $\Omega$ )

**DATA** CKP sensor resistance: 190 – 290  $\Omega$  (Green – Blue)  
 $\infty$   $\Omega$  (Green – Ground)

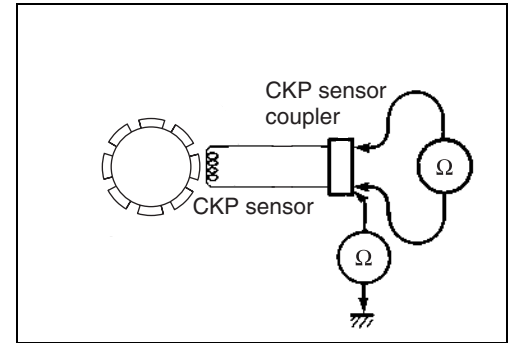

# SPEEDOMETER AND TACHOMETER

## DESCRIPTION

This speedometer and tachometer mainly consists of the stepping motor (except for tachometer), LCD (Liquid Crystal Display) and LED (Light Emitting Diode).

The speedometer pointer is driven by the stepping motor.

The LCDs indicate Tachometer, Engine coolant and Oil pressure temp mark, Odo/Trip1/Trip2/FI and Clock, Fuel level respectively.

### LED (Light Emitting Diode)

LED is used for the illumination light and each indicator light.

LED is maintenance free. LED is less electric-power consuming and stronger to vibration resistance compared to the bulb.

### Tachometer indicator lamp

The tachometer light up for 1.0 second and then it operates 9 000 → 0 r/min one time.

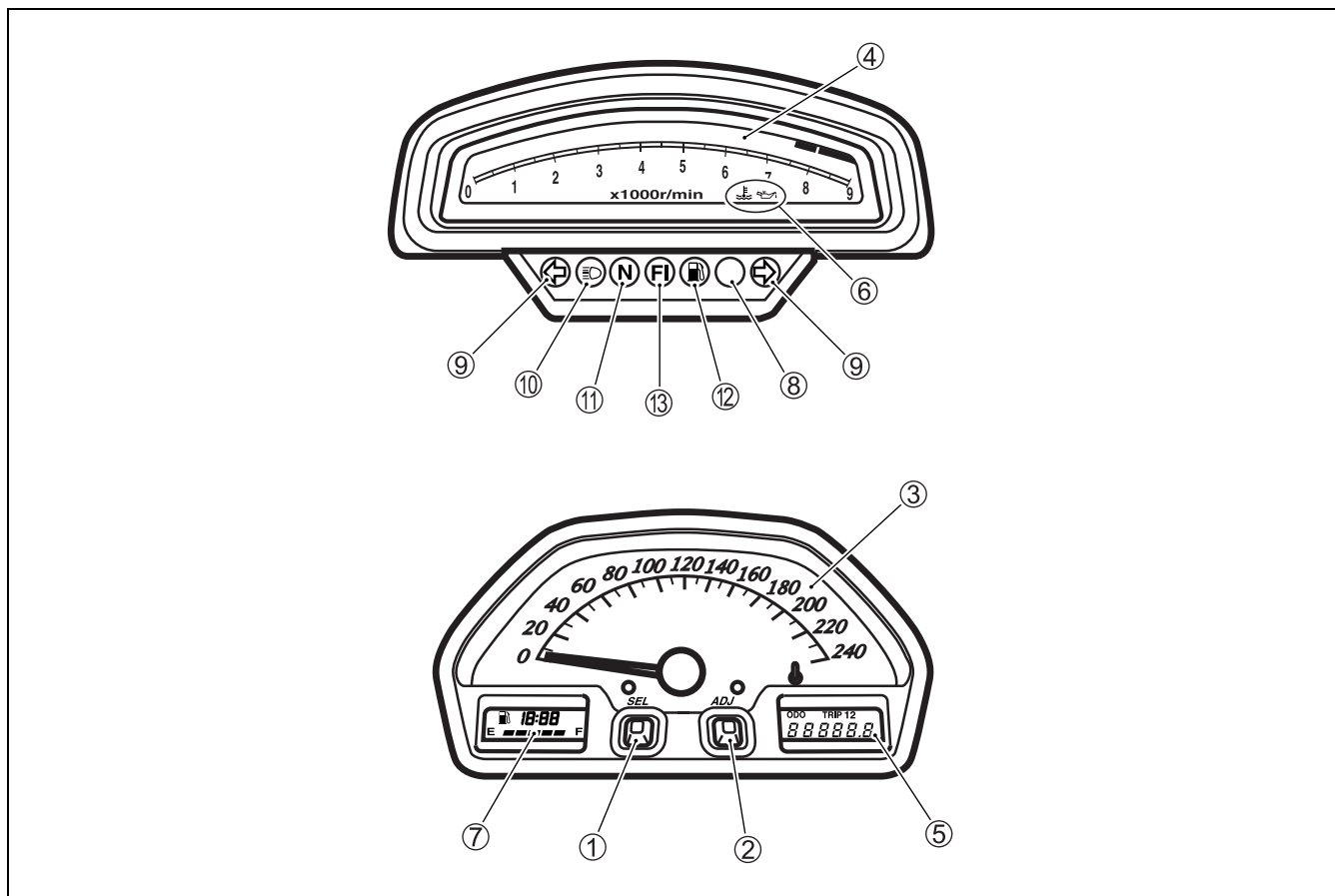

①	Select switch (Odo/Trip1/Trip2/FI)	⑧	LED (Oil pressure/Engine coolant temperature indicator light)
②	Adjust switch (Trip/Clock)	⑨	LED (Turn signal indicator light)
③	Speedometer	⑩	LED (High-beam indicator light)
④	Tachometer	⑪	LED (Neutral indicator light)
⑤	LCD (Odo/Trip1/Trip2/FI)	⑫	LED (Fuel level indicator light)
⑥	LCD (Oil pressure/Engine coolant temperature indicator mark)	⑬	LED (FI indicator light)
⑦	LCD (Clock/Fuel level)		

## SPEEDOMETER REMOVAL AND DISASSEMBLY

- Disconnect the speedometer lead wire coupler. (☞ 6-3)
- Remove the screw.
- Remove the speedometer ①.

NOTE:

“☆” indicates hook location.

### CAUTION

**When disconnecting and reconnecting the speedometer coupler, make sure to turn OFF the ignition switch, or electronic parts may get damaged.**

- Disassemble the speedometer as follows.

### CAUTION

**Do not attempt to disassemble the speedometer unit ②.**

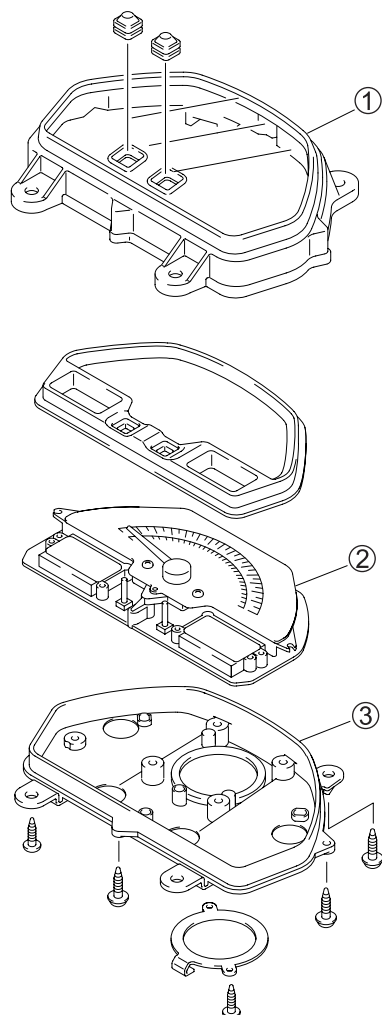
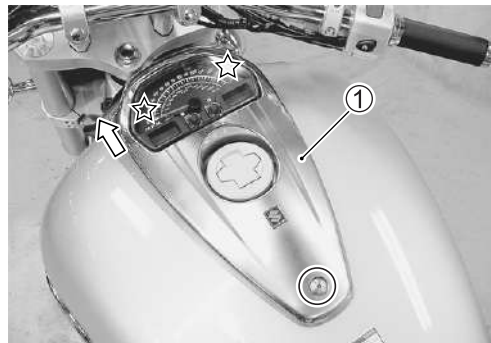

①	Speedometer cover	③	Speedometer case
②	Speedometer unit		

## TACHOMETER REMOVAL AND DISASSEMBLY

- Remove the handlebar. (☞ 9-30)
- Remove the head light. (☞ 9-15)
- Remove the screws ①.
- Disconnect the tachometer lead wire coupler and remove the tachometer ②.
- Disassemble the tachometer as follows.

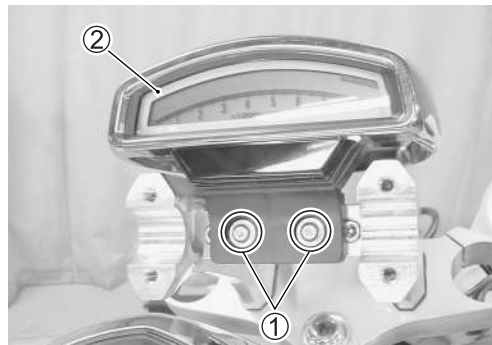

### CAUTION

Do not attempt to disassemble the tachometer unit ②.

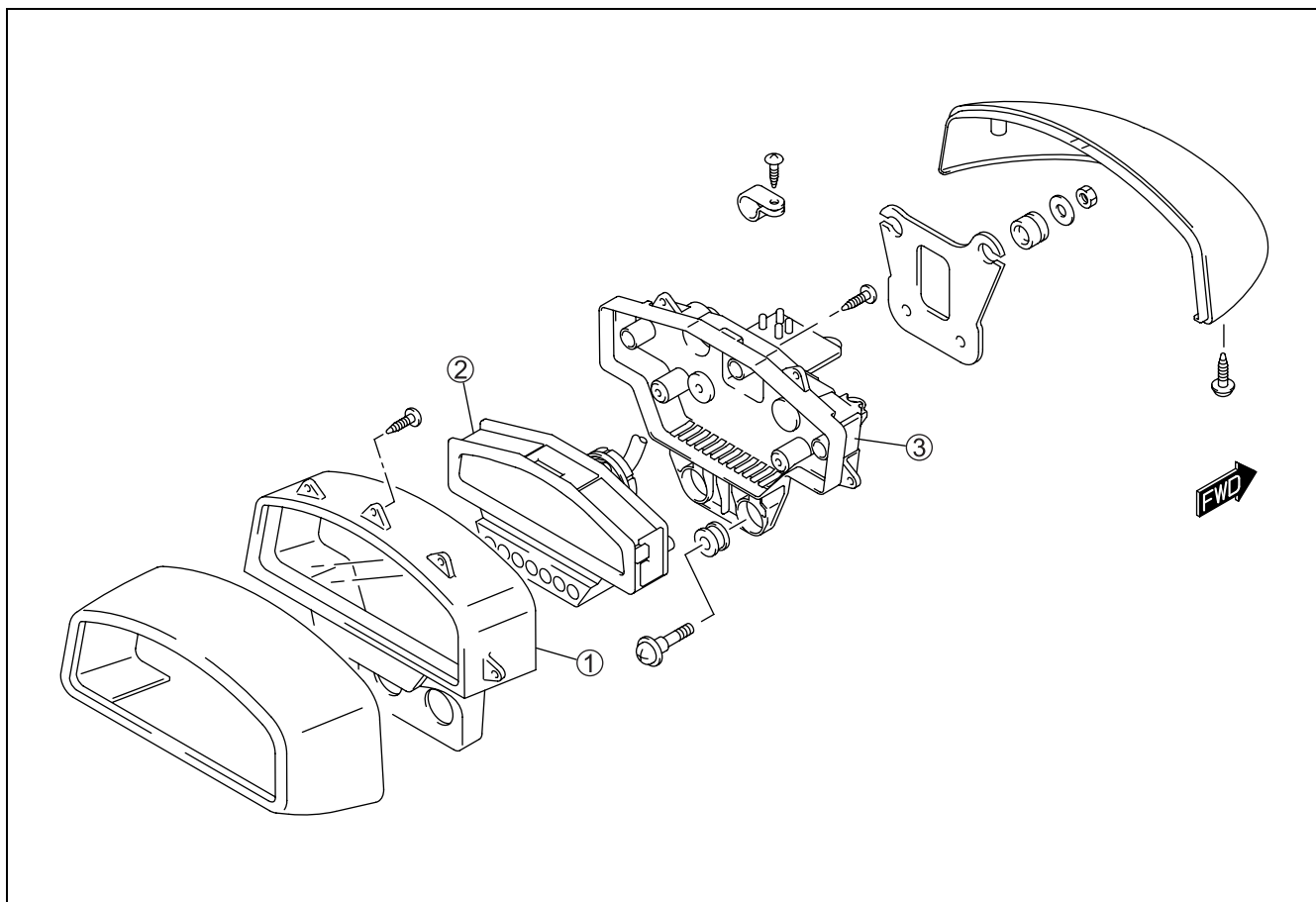

① Tachometer cover

③ Tachometer case

② Tachometer unit

## INSPECTION

### LED (LIGHT EMITTING DIODE)

Check that the LED lights (FI indicator light, Fuel level indicator light) immediately after turning the ignition switch on. Also, other LED lights (Neutral indicator light, High-beam indicator light and Turn signal indicator light) can be checked by depending on each switch position.

If the LED fails in operation, replace the combination meter unit with a new one after checking its wire harness/coupler.

### STEPPING MOTOR

Check that the pointer calibrates itself immediately after turning the ignition switch on and stops at zero point.

If abnormal condition is found, replace the combination meter unit with a new one after checking its wire harness/coupler.

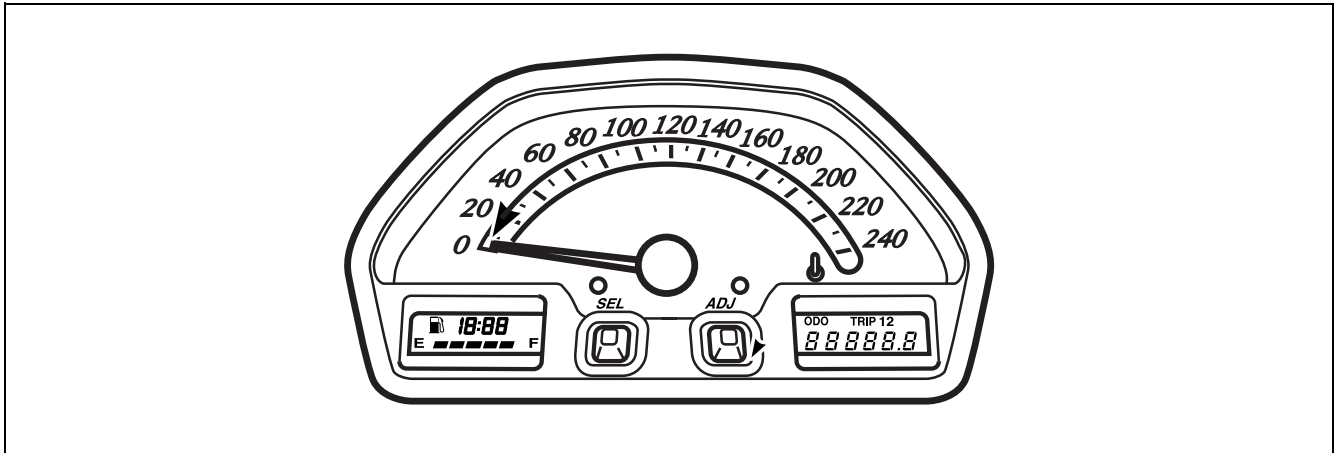

#### NOTE:

The pointer may not return to the proper position even turning the ignition switch on under low temperature condition. In that case, you can reset the pointer to the proper position by following the instruction below:

- 1) With the function switch (A) pressed, turn the ignition switch on.
  - 2) Release the function switch (A), 3 to 5 seconds after turning the ignition switch on.
  - 3) Press the function switch (A) twice (within 1 second). →Reset
- \* Complete the operation within 10 seconds after the ignition switch has been turned on.

Time	Ignition switch	Adjuster switch (A)
0	OFF	PUSH
•	ON	↓
•		
3 sec.		↓
•		↓
5 sec.		Release
•		↓
•		Push
•		↓
•		Push→Reset
10 sec.		

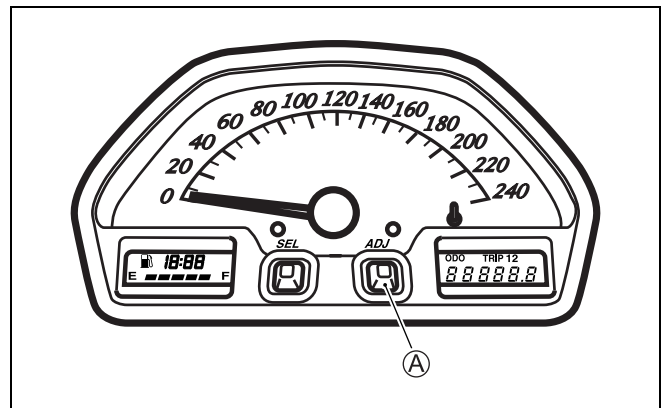

Pointer will return to the starting point right after the completion of the operation. In the case of the pointer not returning to the proper position after doing above, replace the combination meter unit.



**ENGINE COOLANT TEMPERATURE METER AND INDICATOR**

**ECT sensor inspection ( 8-9)**

- Remove the right frame side cover. ( 9-5)
- Remove the right air cleaner box. ( 6-13)
- Disconnect the ECT sensor coupler ①.

**CAUTION**

**When connecting and disconnecting the engine coolant temperature sensor lead wire coupler, make sure to turn OFF the ignition switch, or electronic parts may get damaged.**

- Connect the variable resistor ① between the terminals.
- Disconnect the oil pressure switch lead wire from the oil pressure switch.

**NOTE:**

*Leave the oil pressure switch lead wire open.*

- Turn the ignition switch ON.
- Check the LCD and LED operations when the resistance is adjusted to the specified values.

Resistance ①	LED ②	LCD ③	Water temperature
0.1 kΩ and over	OFF	—	120 °C below
0.1 kΩ and below	ON	ON	120 °C and over

If either one or all indications are abnormal, replace the combination meter with a new one.

**NOTE:**

*If the engine stop switch is turned OFF or side-stand/ignition inter-lock system is not working while the ignition switch is ON, the LCD displays "CHEC". But it is not a malfunction.*

*This condition implies that combination meter receives no signal from the ECM.*

*In that case, they are restored to normal indication by turning the engine stop switch to RUN position.*

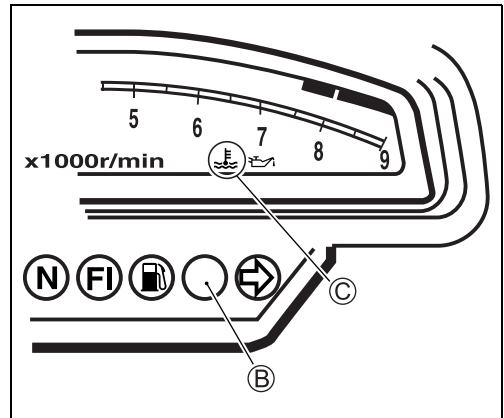
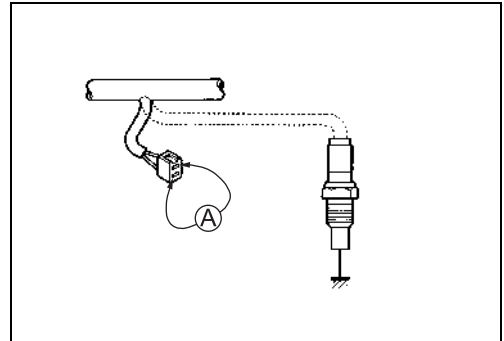
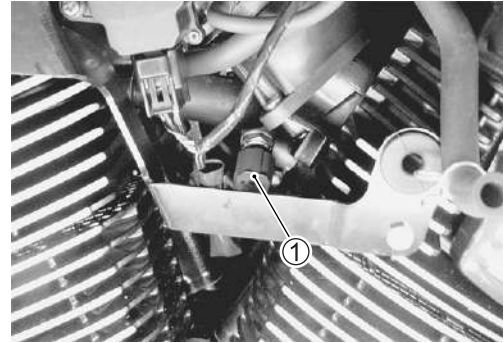

**FUEL LEVEL INDICATOR SWITCH INSPECTION**

- Remove and disassemble the fuel pump assembly. (☞ 6-8)
- Connect 12 V battery and test bulb (12 V, 3.4 W) to the fuel level indicator switch as shown in the right illustration. The bulb should come on after one minutes if the switch is in good condition.

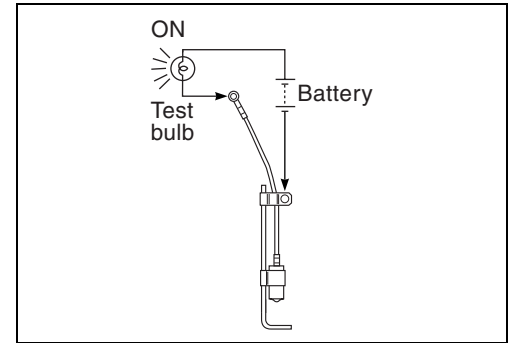

- When the switch is immersed in kerosene under the above condition, the bulb should go out. If the bulb remains lit, replace the unit with a new one.

**CAUTION**

- \* When the bulb turns off, immediately pick up the switch from kerosene.
- \* After the check has been completed, wash the switch with gasoline.

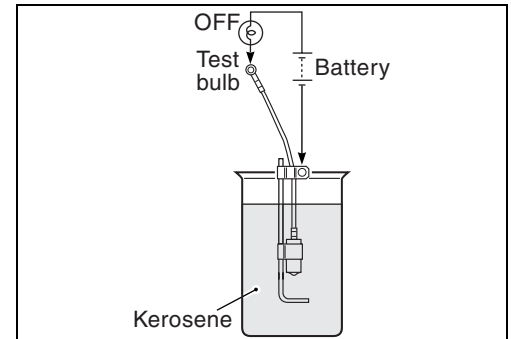
**FUEL LEVEL INDICATOR LIGHT INSPECTION**

If the fuel level indicator light does not function properly, check the fuel level indicator switch and its lead wire/coupler.

If the fuel level indicator switch and its lead wire/coupler are functioning properly, replace the tachometer with a new one.

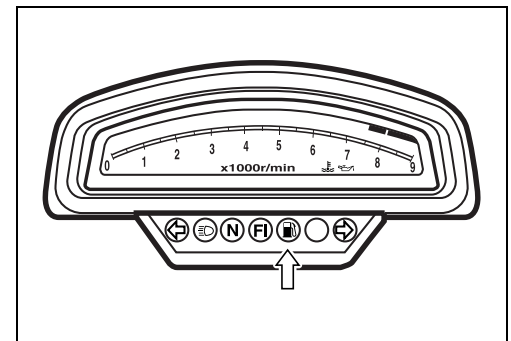

**FUEL LEVEL METER INSPECTION**

- Lift and support the fuel tank. (☞ 6-3)
- Disconnect the fuel pump lead wire coupler ①.
- Connect variable resistor between the Light green and Black lead wires at the wire harness.
- Turn the ignition switch “ON” position and wait for approx. 40 seconds.

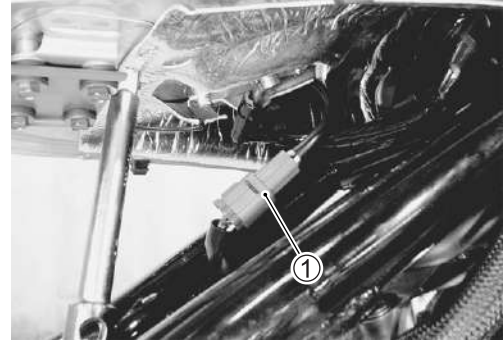

Check the display of fuel meter as shown below, If any abnormality is found, replace the combination meter with a new one.

**NOTE:**

Side-stand is “ON” (side-stand up) position when inspecting it.

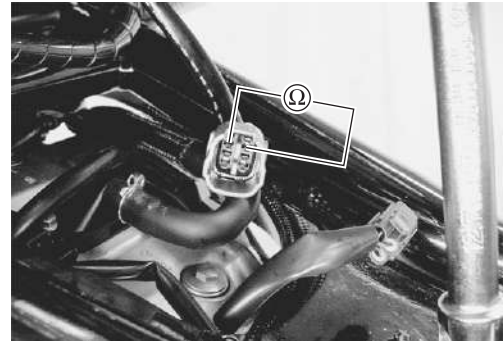

Resistance	More than 190 Ω	More than 190 Ω	121 – 190 Ω	70 – 121 Ω	17 – 70 Ω	Less than 17 Ω
Thermistor	ON	OFF	OFF	OFF	OFF	OFF
Fuel level meter						
Fuel indicator light	ON	Flicker	OFF	OFF	OFF	OFF

**FUEL LEVEL GAUGE INSPECTION**

- Remove the fuel level gauge assembly. (☞ 6-8)
- Measure the resistance at each fuel level gauge float position. If the resistance is incorrect, replace the fuel level gauge with a new one.

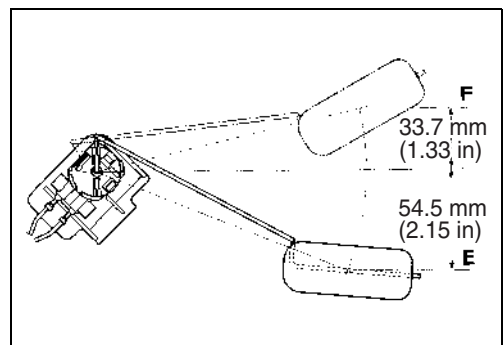

Float position	Resistance
33.7 mm (1.33 in)	Approx. 10 Ω
54.5 mm (6.67 in)	Approx. 216 Ω

**09900-25008: Multi-circuit tester set**

**Tester knob indication: Resistance (Ω)**

## SPEEDOMETER

If the speedometer, odometer or trip meter does not function properly, inspect the speedometer sensor and connection of couplers. If the speed sensor and connection are functioning properly, replace the meter with a new one.

### SPEEDOMETER SENSOR

- Remove the left frame side cover. (☞ 9-5)
- Remove the secondary gear case cover. (☞ 3-6)
- Disconnect speedometer sensor coupler ①.
- Remove the speedometer sensor ② by removing its mounting bolt.
- Connect 12 V battery, 10 k $\Omega$  resistor and the multi-circuit tester as shown in the right illustration.

**O/R** : Orange with Red tracer

**B/W** : Black with White tracer

**P** : Pink

 **09900-25008: Multi-circuit tester set**

 **Tester knob indication: Voltage (---)**

- Under above condition, if a suitable screwdriver touching the pick-up surface of the speedometer sensor is moved, the tester reading voltage changes (0 V→12 V or 12 V→0 V). If the tester reading voltage does not change, replace the speedometer sensor with a new one.

#### NOTE:

*The highest voltage reading in this test will be the same as that of battery (12 V).*

- Apply SUZUKI SUPER GREASE “A” to the speedometer sensor O-ring before installing it.

 **99000-25010: SUZUKI SUPER GREASE “A”**  
or equivalent

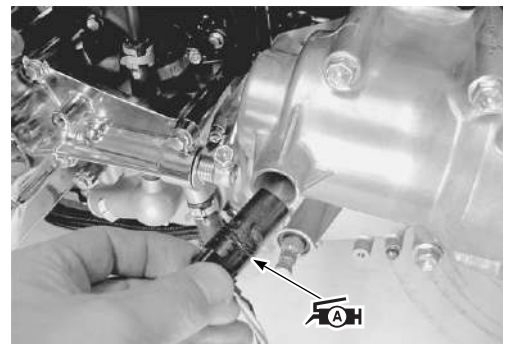
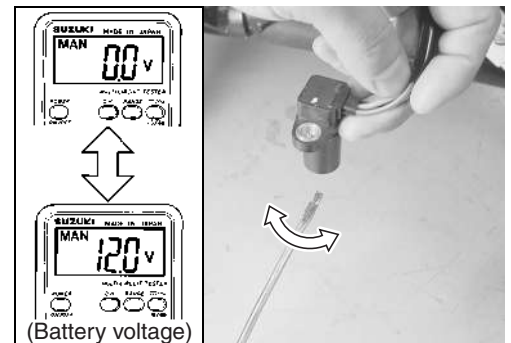
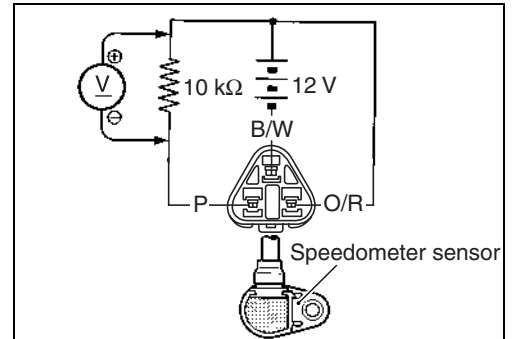
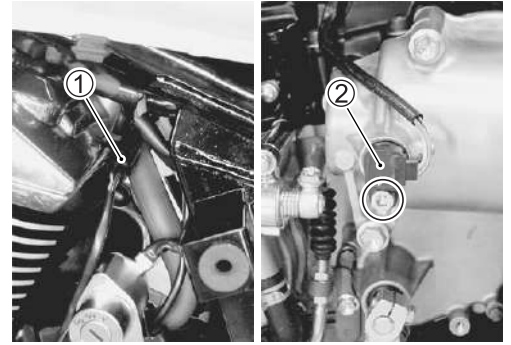

**OIL PRESSURE INDICATOR****NOTE:**

Before inspecting the oil pressure switch, check if the engine oil level is correct. (☞ 2-17)

- Disconnect the oil pressure switch lead wire from the oil pressure switch.
- Turn the ignition switch ON.
- Check if the oil pressure indicator (A) and LCD (B) will light, when grounding the lead wire.

If any indications are abnormal, replace the combination meter with a new one after checking connection of couplers.

**NOTE:**

Install the rubber cover correctly after inspecting it.

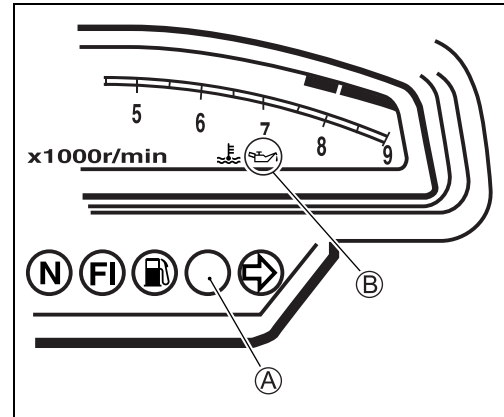
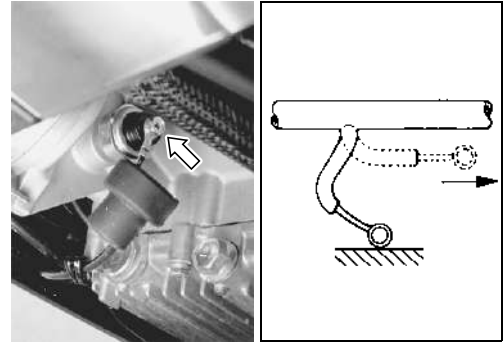

## LAMPS

### HEADLIGHT, BRAKE LIGHT/TAILLIGHT, LICENSE PLATE LIGHT AND TURN SIGNAL LIGHT

#### HEADLIGHT

12 V 60/55 W ①

POSITION LIGHT ..... (E-02, 19, 24)

12 V 5 W

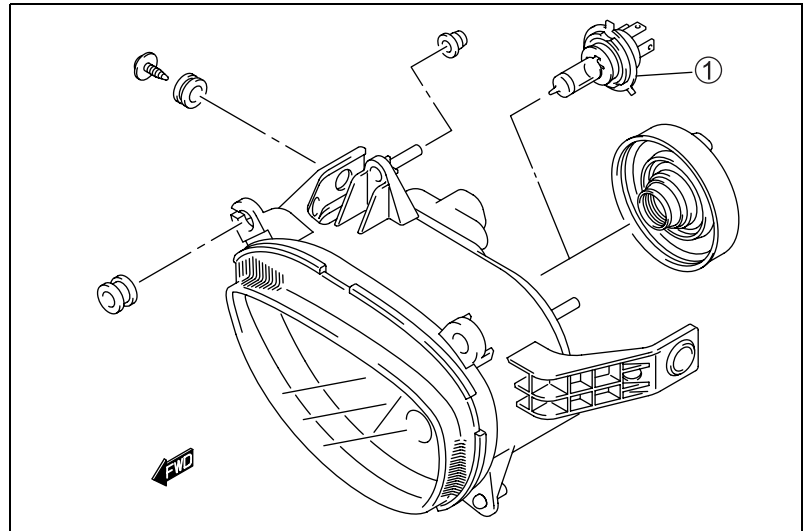

#### BRAKE LIGHT/TAILLIGHT

LED

#### LICENCE PLATE LIGHT

12 V 5 W ②

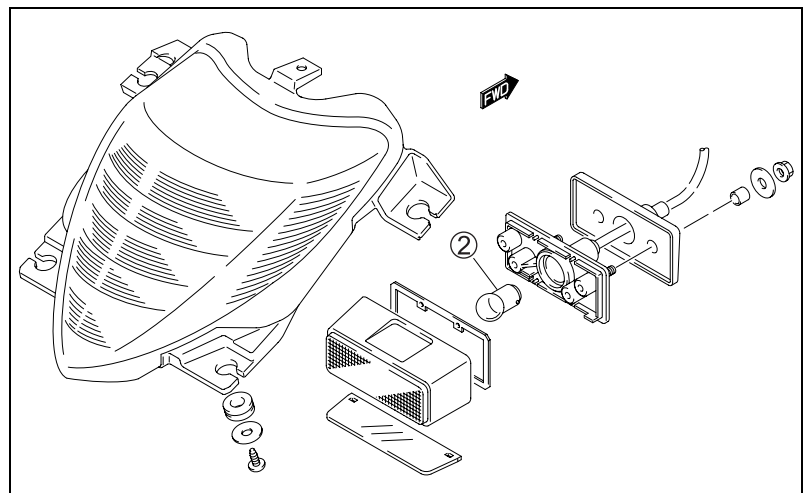

#### TURN SIGNAL/POSITION LIGHT

(E-03, 28, 33)

12 V 21 W/5 W × 2 ③

12 V 21 W × 2 ④

TURN SIGNAL LIGHT ..... (E-02, 19, 24)

12 V 21 W × 4 ⑤

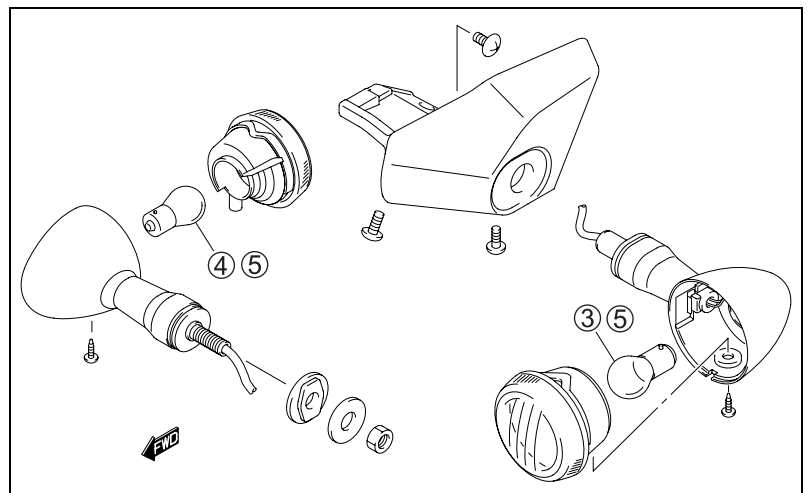

#### CAUTION

If you have touched the bulb with your bare hands, clean it with a cloth moistened with alcohol or soapy water to maintain lens clarity.



## HEADLIGHT RELAY INSPECTION

headlight relay is located in front of the battery.

- Remove the right frame side cover. (☞ 9-5)
- Remove the headlight relay ①.

First check the insulation between ① and ② terminals with tester. Then apply 12 volts to ③ and ④ terminals, + to ③ and - to ④, and check the continuity between ① and ②.

If there is no continuity, replace it with a new one.

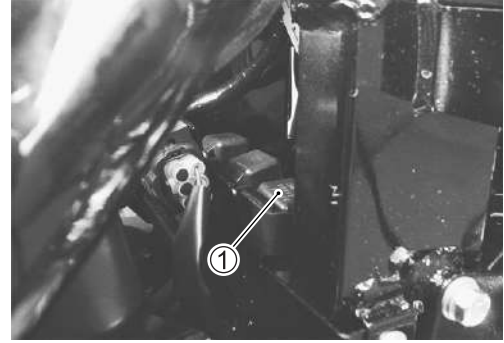

**TOOL** 09900-25008: Multi-circuit tester set

**Tester knob indication: Continuity test (•••)**

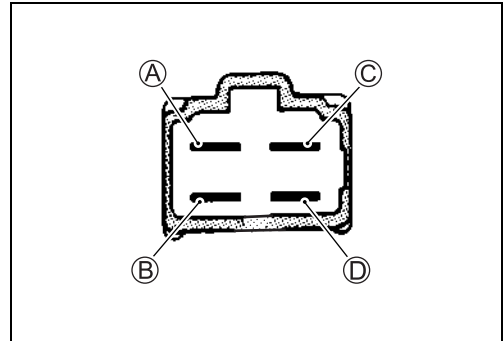

## HEADLIGHT BEAM ADJUSTMENT

- Adjust the headlight beam.

**NOTE:**

*To adjust the headlight beam, adjust the beam horizontally first, then adjust vertically.*

Ⓐ: Horizontal adjuster

Ⓑ: Vertical adjuster

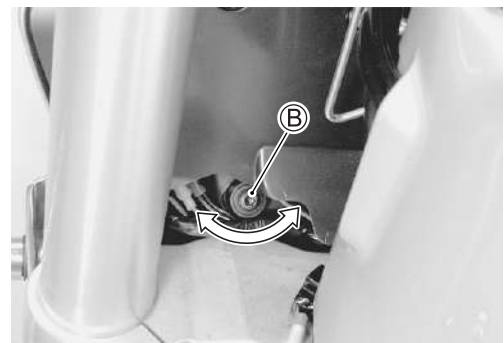

## RELAYS

### TURN SIGNAL/SIDE-STAND RELAY

The turn signal/side-stand relay is composed of the turn signal relay, side-stand relay and diode.



#### INSPECTION

Before removing the turn signal/side-stand relay, check the operation of the turn signal light.

If the turn signal light does not illuminate, inspect the bulb, turn signal switch and circuit connection.

If the bulb, turn signal switch and circuit connection are OK, the turn signal relay may be faulty. In this case, replace the turn signal/side-stand relay with a new one.

#### NOTE:

\* Make sure that the battery is fully charged.

\* Refer to the page 10-21 for the side-stand relay and diode inspection.

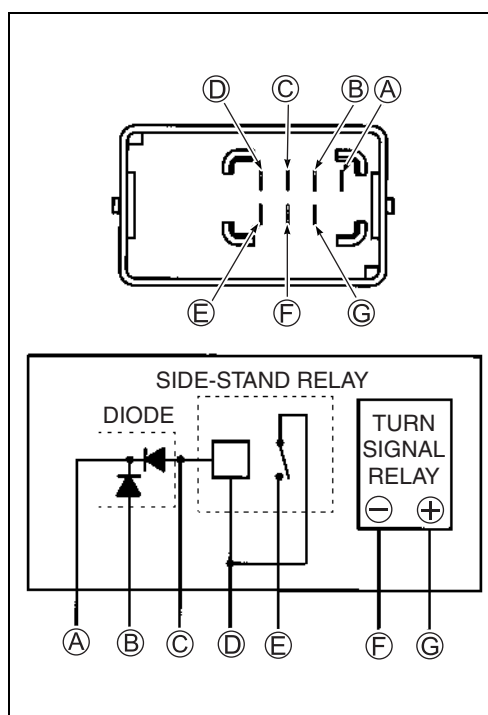

### STARTER RELAY

👉 10-18

### FUEL PUMP RELAY

👉 6-6

### COOLING FAN RELAY

👉 8-8

## SWITCHES INSPECTION

Inspect each switch for continuity with a tester. If any abnormality is found, replace the respective switch assemblies with new ones.

### HAZARD SWITCH

Color	Lg	Lbl	B
Position			
• (OFF)			
△ (ON)	○	○	○

### IGNITION SWITCH

Color	R	O	O/Y	Gr	Br
Position					
ON	○	○	○	○	○
OFF					
LOCK					
P	○				○

### DIMMER SWITCH

Color	W	Y	Y/W
Position			
HI (☹)		○	○
LO (☺)	○		○

### TURN SIGNAL SWITCH

Color	Lg	Lbl	B
Position			
L		○	○
PUSH			
R	○	○	

### PASSING LIGHT SWITCH

Color	Y/W	Y
Position		
•		
PUSH	○	○

### ENGINE STOP SWITCH

Color	O/B	O/W
Position		
OFF (⊗)		
RUN (⊙)	○	○

### STARTER BUTTON

Color	O/W	Y/G
Position		
•		
PUSH	○	○

### HORN BUTTON

Color	B/Bl	B/W
Position		
•		
PUSH	○	○

### FRONT BRAKE SWITCH

Color	B/R	B/Bl
Position		
OFF		
ON	○	○

### REAR BRAKE SWITCH

Color	O/G	W/B
Position		
OFF		
ON	○	○

### CLUTCH LEVER POSITION SWITCH

Color	B/Y	B/Y
Position		
OFF		
ON	○	○

### OIL PRESSURE SWITCH

Color	G/Y	Ground
Position		
ON (engine is at stop)	○	○
OFF (engine is running)		

#### NOTE:

Before inspecting the oil pressure switch, check if the engine oil level is correct. (☞ 2-17)

### WIRE COLOR

**B** : Black      **Lbl** : Light blue      **R** : Red  
**Br** : Brown      **Lg** : Light green      **W** : White  
**Gr** : Gray      **O** : Orange      **Y** : Yellow  
**B/Bl** : Black with Blue tracer  
**B/R** : Black with Red tracer  
**B/W** : Black with White tracer  
**B/Y** : Black with Yellow tracer  
**G/Y** : Green with Yellow tracer  
**O/B** : Orange with Black tracer  
**O/G** : Orange with Green tracer  
**O/W** : Orange with White tracer  
**O/Y** : Orange with Yellow tracer  
**W/B** : White with Black tracer  
**Y/G** : Yellow with Green tracer  
**Y/W** : Yellow with White tracer

## BATTERY SPECIFICATIONS

Type designation	FTZ16-BS
Capacity	12 V, 64.8 kC (18 Ah)/10 HR

- |                        |                                |
|------------------------|--------------------------------|
| ① Upper cover breather | ⑤ Terminal                     |
| ② Cathode plates       | ⑥ Safety valve                 |
| ③ Stopper              | ⑦ Anode plates                 |
| ④ Filter               | ⑧ Separator (Fiberglass plate) |

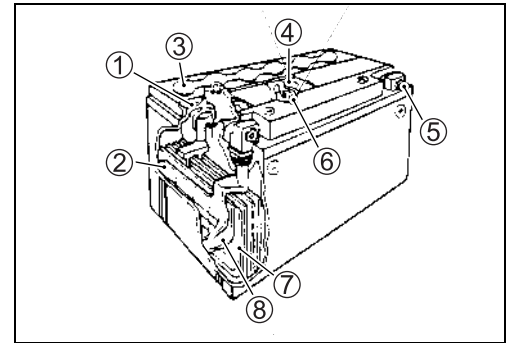

## INITIAL CHARGING

### Filling electrolyte

- Remove the aluminum tape ① sealing the battery electrolyte filler holes (A).

#### NOTE:

When filling electrolyte, the battery must be removed from the motorcycle and must be put on the level ground.

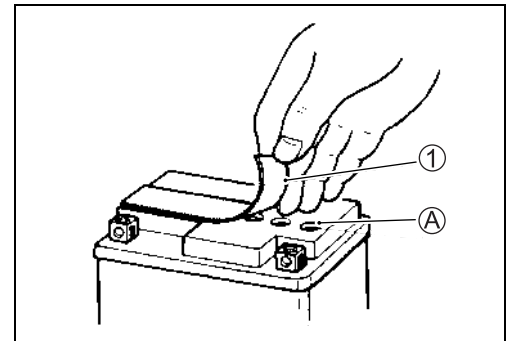

- Remove the caps ②.

#### NOTE:

\* After filling the electrolyte completely, use the removed cap ② as sealing caps of battery-filler holes.

\* Do not remove or pierce the sealed areas ③ of the electrolyte container.

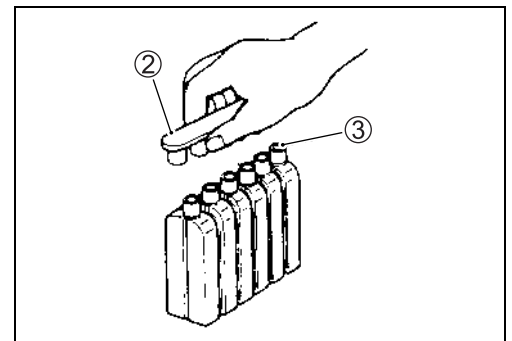

- Insert the nozzles of the electrolyte container ④ into the battery's electrolyte filler holes, holding the container firmly so that it does not fall. Take precaution not to allow any of the fluid to spill.

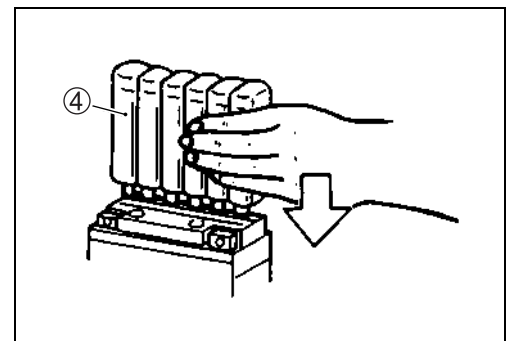

- Make sure air bubbles ⑤ are coming up each electrolyte container, and leave in this position for about more than 20 minutes.

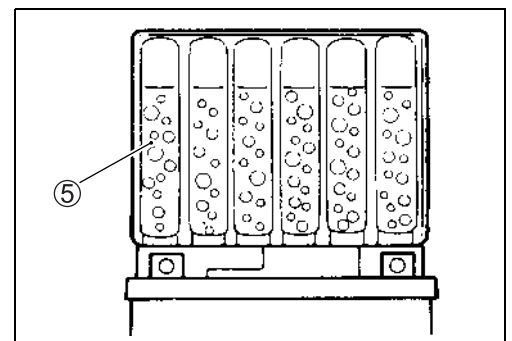

**NOTE:**

If no air bubbles are coming up from a filler port, tap the bottom of the electrolyte container two or three times.

Never remove the container from the battery.

- After confirming that the electrolyte has entered the battery completely, remove the electrolyte containers from the battery. Wait for about 20 minutes.

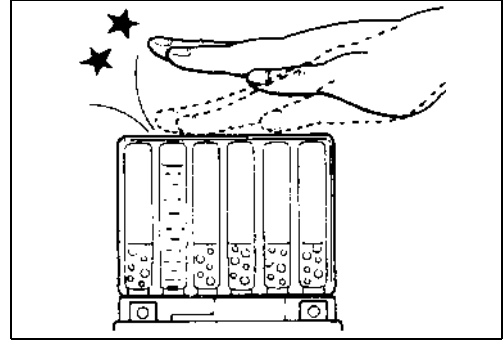

- Insert the caps ⑥ into the filler holes, pressing in firmly so that the top of the caps do not protrude above the upper surface of the battery's top cover.

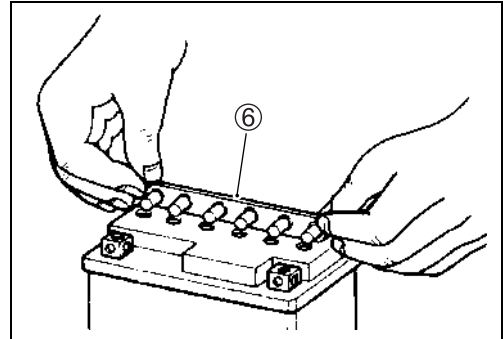
**CAUTION**

- \* Never use anything except the specified battery.
- \* Once the caps have been installed to the battery, do not remove the caps.
- \* Do not tap the caps with a tool such as hammer when installing them.

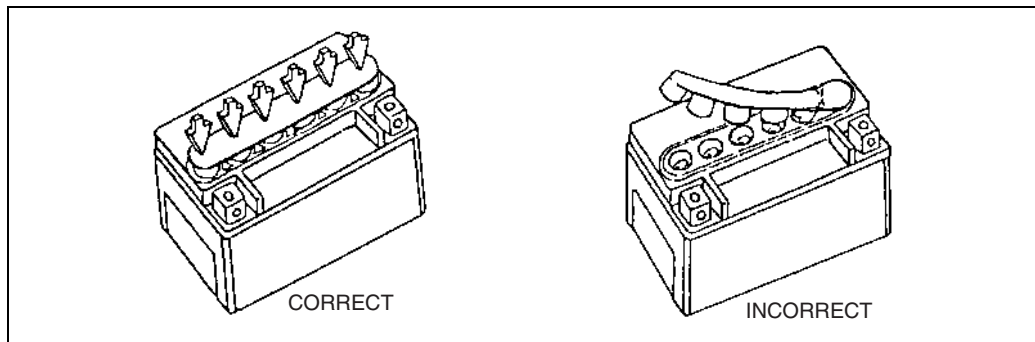

For initial charging, use the charger specially designed for MF battery.

**CAUTION**

- \* For charging the battery, make sure to use the charger specially designed for MF battery. Otherwise, the battery may be overcharged resulting in shortened service life.
- \* Do not remove the cap during charging.
- \* Position the battery with the cap facing upward during charging.

## SERVICING

Visually inspect the surface of the battery container. If any signs of cracking or electrolyte leakage from the sides of the battery have occurred, replace the battery with a new one. If the battery terminals are found to be coated with rust or an acidic white powdery substance, clean the battery terminals with sandpaper.

## RECHARGING OPERATION

- Using the multi-circuit tester, check the battery voltage. If the voltage reading is the 12.0 V (DC) and less, recharge the battery with a battery charger.

- Ⓐ Charging period
- Ⓑ Stop charging

### CAUTION

- \* When recharging the battery, remove the battery from the motorcycle.
- \* Do not remove the caps on the battery top while recharging.

Recharging time: 9 A for 1 hour or 1.8 A for 5 to 10 hours

### CAUTION

**Be careful not to permit the charging current to exceed 9 A at any time.**

- After recharging, wait for 30 minutes and more and check the battery voltage with a multi-circuit tester.
- If the battery voltage is the 12.5 V and less, recharge the battery again.
- If battery voltage is still 12.5 V and less, after recharging, replace the battery with a new one.
- When the motorcycle is not used for a long period, check the battery every 1 month to prevent the battery discharge.

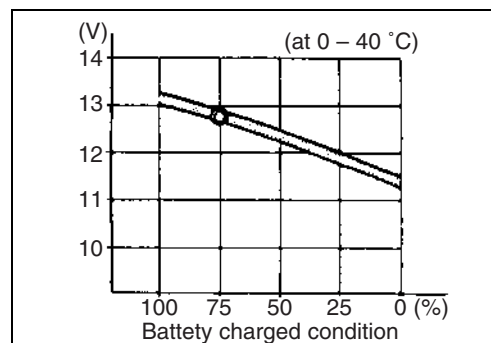
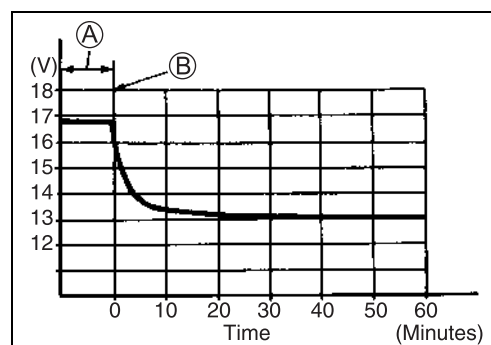



# SERVICING INFORMATION

## CONTENTS

<b>TROUBLESHOOTING .....</b>	<b>11- 3</b>
<b>FI SYSTEM MALFUNCTION CODE AND DEFECTIVE CONDITION.....</b>	<b>11- 3</b>
<b>ENGINE .....</b>	<b>11- 7</b>
<b>RADIATOR (COOLING SYSTEM).....</b>	<b>11-13</b>
<b>CHASSIS .....</b>	<b>11-14</b>
<b>SHAFT DRIVE .....</b>	<b>11-15</b>
<b>BRAKES.....</b>	<b>11-15</b>
<b>ELECTRICAL .....</b>	<b>11-16</b>
<b>BATTERY.....</b>	<b>11-17</b>
<b>SPECIAL TOOLS .....</b>	<b>11-18</b>
<b>TIGHTENING TORQUE .....</b>	<b>11-22</b>
<b>ENGINE .....</b>	<b>11-22</b>
<b>DRIVELINE/AXLE .....</b>	<b>11-23</b>
<b>FI SYSTEM AND INTAKE AIR SYSTEM.....</b>	<b>11-23</b>
<b>COOLING SYSTEM.....</b>	<b>11-23</b>
<b>CHASSIS.....</b>	<b>11-24</b>
<b>TIGHTENING TORQUE CHART.....</b>	<b>11-25</b>
<b>SERVICE DATA.....</b>	<b>11-26</b>
<b>WIRING HARNESS, CABLE AND HOSE ROUTING.....</b>	<b>11-35</b>
<b>WIRING HARNESS ROUTING.....</b>	<b>11-35</b>
<b>ENGINE ELECTRICAL PARTS LEAD WIRE ROUTING.....</b>	<b>11-37</b>
<b>CABLE ROUTING .....</b>	<b>11-38</b>
<b>FRONT BRAKE HOSE ROUTING .....</b>	<b>11-39</b>
<b>REAR BRAKE HOSE ROUTING .....</b>	<b>11-40</b>
<b>THROTTLE BODY HOSE ROUTING.....</b>	<b>11-41</b>
<b>COOLING SYSTEM HOSE ROUTING.....</b>	<b>11-42</b>
<b>PAIR (AIR SUPPLY) SYSTEM HOSE ROUTING (FOR E-03, 28, 33).....</b>	<b>11-43</b>
<b>PAIR (AIR SUPPLY) SYSTEM HOSE ROUTING (FOR THE OTHERS).....</b>	<b>11-44</b>
<b>FUEL TANK INSTALLATION .....</b>	<b>11-45</b>
<b>FRAME HEAD COVER AND RADIATOR COVER INSTALLATION.....</b>	<b>11-46</b>
<b>FRAME HEAD COVER CUSHION INSTALLATION .....</b>	<b>11-47</b>
<b>RADIATOR UPPER COVER CUSHION INSTALLATION .....</b>	<b>11-47</b>
<b>LEFT FRAME COVERS INSTALLATION.....</b>	<b>11-48</b>
<b>RIGHT FRAME COVERS INSTALLATION.....</b>	<b>11-49</b>
<b>HEADLIGHT COVER INSTALLATION.....</b>	<b>11-50</b>

# SERVICING INFORMATION

## CONTENTS

<b>IGNITION COIL INSTALLATION .....</b>	<b>11-51</b>
<b>SIDE-STAND INSTALLATION.....</b>	<b>11-51</b>
<b>REAR TURN SIGNAL LIGHT, LICENSE LIGHT WIRE ROUTING ....</b>	<b>11-52</b>
<b>SEAT LOCK CABLE ROUTING .....</b>	<b>11-52</b>
<b>LICENSE LIGHT AND LICENSE PLATE INSTALLATION .....</b>	<b>11-53</b>
<b>BRAKE LIGHT/TAILLIGHT INSTALLATION .....</b>	<b>11-53</b>

## TROUBLESHOOTING

### FI SYSTEM MALFUNCTION CODE AND DEFECTIVE CONDITION

DTC No.	DETECTED ITEM	DETECTED FAILURE CONDITION	CHECK FOR		
C00	NO FAULT	—————	—————		
C12	CKP sensor	The signal does not reach ECM for 3 sec. or more, after receiving the starter signal.	CKP sensor wiring and mechanical parts CKP sensor, lead wire/coupler connection		
P0335					
C13/C17	IAP sensor	The sensor should produce following voltage. $0.5\text{ V} \leq \text{sensor voltage} < 4.85\text{ V}$ In other than the above range, C13 (P1750) or C17 (P0105) is indicated.	IAP sensor, lead wire/coupler connection		
P1750/P0105					
P1750/ P0105				H	IAP sensor circuit shorted to VCC or ground circuit open
				L	IAP sensor circuit open or shorted to ground or VCC circuit open
C14	TP sensor	The sensor should produce following voltage. $0.2\text{ V} \leq \text{sensor voltage} < 4.80\text{ V}$ In other than the above range, C14 (P0120) is indicated.	TP sensor, lead wire/coupler connection		
P0120					
P0120				H	TP sensor circuit shorted to VCC or ground circuit open
				L	TP sensor circuit open or shorted to ground or VCC circuit open
C15	ECT sensor	The sensor voltage should be the following. $0.15\text{ V} \leq \text{sensor voltage} < 4.85\text{ V}$ In other than the above range, C15 (P0115) is indicated.	ECT sensor, lead wire/coupler connection		
P0115					
P0115				H	ECT sensor circuit open or ground circuit open
				L	ECT sensor circuit shorted to ground
C21	IAT sensor	The sensor voltage should be the following. $0.15\text{ V} \leq \text{sensor voltage} < 4.85\text{ V}$ In other than the above range, C21 (P0110) is indicated.	IAT sensor, lead wire/coupler connection		
P0110					
P0110				H	IAT sensor circuit open or ground circuit open
	L	IAT sensor circuit shorted to ground			

DTC No.		DETECTED ITEM	DETECTED FAILURE CONDITION	CHECK FOR		
C23		TO sensor	The sensor voltage should be the following for 2 sec. and more, after ignition switch is turned ON. $0.2\text{ V} \leq \text{sensor voltage} < 4.8\text{ V}$ In other than the above value, C23 (P1651) is indicated.	TO sensor, lead wire/coupler connection		
P1651						
P1651	H		Sensor voltage is higher than specified value.	TO sensor circuit shorted to VCC or ground circuit open		
	L		Sensor voltage is lower than specified value.	TO sensor circuit open or shorted to ground or VCC circuit open		
C24/C25 C26/C27		Ignition signal	CKP sensor (pick-up coil) signal is produced, but signal from ignition coil is interrupted 8 times or more continuously. In this case, the code C24 (P0351), C25 (P0352), C26 (P0353) or C27 (P0354) is indicated.	Ignition coil, wiring/coupler connection, power supply from the battery		
P0351/P0352 P0353/P0354						
C28		Secondary throttle valve actuator	When no actuator control signal is supplied from the ECM, communication signal does not reach ECM or operation voltage does not reach STVA motor, C28 (P1655) is indicated. STVA can not operate.	STVA motor, STVA lead wire/coupler		
P1655						
C29		STP sensor	The sensor should produce following voltage. $0.15\text{ V} \leq \text{sensor voltage} < 4.85\text{ V}$ In other than the above range, C29 (P1654) is indicated.	STP sensor, lead wire/coupler connection		
P1654						
P1654	H				Sensor voltage is higher than specified value.	STP sensor circuit shorted to VCC or ground circuit open
	L				Sensor voltage is lower than specified value.	STP sensor circuit open or shorted to ground or VCC circuit open
C31		Gear position signal	Gear position signal voltage should be higher than the following for 3 seconds and more. Gear position sensor voltage $> 0.6\text{ V}$ If lower than the above value, C31 (P0705) is indicated.	GP switch, wiring/coupler connection, gearshift cam, etc.		
P0705						
C32/C33		Fuel injector	CKP sensor (pickup coil) signal is produced, but fuel injector signal is interrupted 4 times or more continuously. In this case, the code C32 (P0201) or C33 (P0202) is indicated.	Fuel injector, wiring/coupler connection, power supply to the injector		
P0201/P0202						

DTC No.		DETECTED ITEM	DETECTED FAILURE CONDITION	CHECK FOR
C40 P0505	H	ISC valve	ISC valve motor current is higher than specified value.	ISC valve circuit shorted to BATT or ground circuit open
	L		ISC valve motor circuit is open.	ISC valve circuit open or BATT circuit open
P0506			Idle speed is lower than the desired idle speed.	W/Y or Lg wire open or ground circuit open Air circuit clogged ISC valve is fixed
P0507			Idle speed is higher than the desired idle speed.	W/Y or Dgr wire open or shorted or ground circuit open ISC valve is fixed ISC valve hose connection
C41		Fuel pump relay	No voltage is applied to the fuel pump, although fuel pump relay is turned ON, or voltage is applied to fuel pump although fuel pump relay is turned OFF.	Fuel pump relay, lead wire/coupler connection, power source to fuel pump relay and fuel injectors
P0230				
P0230	H		Voltage is applied to fuel pump although fuel pump relay is turned OFF.	Fuel pump relay switch circuit shorted to power source Fuel pump relay (switch side)
	L		No voltage is applied to the fuel pump, although fuel pump relay is turned ON.	Fuel pump relay circuit open or short Fuel pump relay (coil side).
C42 P1650		Ignition switch	Ignition switch signal is not input to ECM.	Ignition switch, lead wire/coupler
C44/C64		HO2 sensor (E-02, 19, 24)	HO2 sensor output voltage is not input to ECM during engine operation and running condition. (Sensor voltage < 0.45 V) In other than the above value, C44 (P0156/0130) is indicated.	HO2 sensor circuit open or shorted to ground
P0156/P0130				
C44/C64			The Heater can not operate so that heater operation voltage is not supply to the oxygen heater circuit, C44 (P0161/0135) is indicated.	HO2 sensor lead wire/coupler connection Battery voltage supply to the HO2 sensor
P0161/P0135				

DTC No.	DETECTED ITEM	DETECTED FAILURE CONDITION	CHECK FOR
C46	Exhaust control valve actuator	EXCVA position sensor produces following voltage. $0.1 \text{ V} \leq \text{sensor voltage} < 4.9 \text{ V}$ In other than the above range, C46 (P1675) is indicated.	EXCVA, EXCVA lead wire/coupler
P1657		When no actuator control signal is supplied from the ECM, communication signal does not reach ECM or operation voltage does not reach EXCVA motor, C46 (P1658) is indicated. EXCVA can not operate.	
P1657	H	EXCVA position sensor voltage is higher than specified value.	EXCVA position sensor circuit shorted to VCC or ground circuit open
	L	EXCVA position sensor voltage is lower than specified value.	EXCVA position sensor circuit open or shorted to ground or VCC circuit open
P1658		When no actuator control signal is supplied from the ECM, communication signal does not reach ECM or operation voltage does not reach EXCVA motor, C46 (P1658) is indicated. EXCVA motor can not operate.	EXCVA, EXCVA motor lead wire/coupler
C49/C61	PAIR control solenoid valve	PAIR control solenoid valve voltage is not input to ECM.	PAIR control solenoid valve, lead wire/coupler
P1768/P1656			
C60	Cooling fan relay	Cooling fan relay signal is not input to ECM.	Cooling fan relay, lead wire/coupler connection
P0480			







Complaint	Symptom and possible causes	Remedy
Noisy engine	<p><b>Excessive valve chatter</b></p> <ol style="list-style-type: none"> <li>1. Too large tappet clearance</li> <li>2. Weakened or broken valve springs</li> <li>3. Worn tappet or cam surface</li> <li>4. Worn and burnt camshaft journal</li> </ol> <p><b>Noise seems to come from piston</b></p> <ol style="list-style-type: none"> <li>1. Worn down pistons or cylinders</li> <li>2. Carbon combustion chambers fouled with carbon</li> <li>3. Worn piston pins or piston pin bore</li> <li>4. Worn piston rings or ring grooves</li> </ol> <p><b>Noise seems to come from timing chain</b></p> <ol style="list-style-type: none"> <li>1. Stretched chain</li> <li>2. Worn sprockets</li> <li>3. Tension adjuster not working</li> </ol> <p><b>Noise seems to come from clutch</b></p> <ol style="list-style-type: none"> <li>1. Worn splines of countershaft or hub</li> <li>2. Worn teeth of clutch plates</li> <li>3. Distorted clutch plates, driven and drive</li> <li>4. Worn clutch release bearing</li> <li>5. Weakened clutch dampers</li> </ol> <p><b>Noise seems to come from crankshaft</b></p> <ol style="list-style-type: none"> <li>1. Rattling bearings due to wear</li> <li>2. Worn and burnt big-end bearings</li> <li>3. Worn and burnt journal bearings</li> <li>4. Too large thrust clearance</li> </ol> <p><b>Noise seems to come from balancer</b></p> <ol style="list-style-type: none"> <li>1. Worn or rubbing balancer gears</li> </ol> <p><b>Noise seems to come from transmission</b></p> <ol style="list-style-type: none"> <li>1. Worn or rubbing gears</li> <li>2. Worn splines</li> <li>3. Worn or rubbing primary gears</li> <li>4. Worn bearings</li> </ol> <p><b>Noise seems to come from water pump</b></p> <ol style="list-style-type: none"> <li>1. Too much play on pump shaft bearing</li> <li>2. Worn or damaged impeller shaft</li> <li>3. Worn or damaged mechanical seal</li> <li>4. Contact between pump case and impeller</li> </ol>	<p>Adjust.</p> <p>Replace.</p> <p>Replace.</p> <p>Replace.</p> <p>Replace.</p> <p>Clean.</p> <p>Replace.</p> <p>Replace.</p> <p>Replace.</p> <p>Replace.</p> <p>Repair or replace.</p> <p>Replace.</p> <p>Replace.</p> <p>Replace.</p> <p>Replace.</p> <p>Replace the primary driven gear.</p> <p>Replace.</p> <p>Replace.</p> <p>Replace.</p> <p>Replace thrust bearing.</p> <p>Replace.</p> <p>Replace.</p> <p>Replace.</p> <p>Replace.</p> <p>Replace.</p> <p>Replace.</p> <p>Replace.</p> <p>Replace.</p> <p>Replace.</p>

Complaint	Symptom and possible causes	Remedy	
<b>Engine runs poorly in high speed range.</b>	<b>Defective engine internal/electrical parts</b>		
	1. Weakened valve springs		Replace.
	2. Worn camshafts		Replace.
	3. Valve timing out of adjustment		Adjust.
	4. Too narrow spark plug gaps		Adjust.
	5. Ignition not advanced sufficiently due to poorly working timing advance circuit		Replace ECM.
	6. Defective ignition coils		Replace.
	7. Defective ignition coil/plug caps		Replace.
	8. Defective CKP sensor		Replace.
	9. Defective ECM		Replace.
	10. Clogged air cleaner element		Clean.
	11. Clogged fuel hose, resulting in inadequate fuel supply to injector		Clean and prime.
	12. Defective fuel pump		Replace.
	13. Defective TP sensor		Replace.
	14. Defective STP sensor or STVA		Replace.
	<b>Defective air flow system</b>		
	1. Clogged air cleaner element		Replace.
	2. Defective throttle valve		Adjust or replace.
	3. Defective secondary throttle valve		Adjust or replace.
	4. Sucking air from throttle body joint		Repair or replace.
	5. Defective ECM		Replace.
	6. Imbalancing throttle valve synchronization		Adjust.
	<b>Defective control circuit or sensor</b>		
	1. Low fuel pressure		Repair or replace.
	2. Defective TP sensor		Replace.
	3. Defective IAT sensor		Replace.
	4. Defective CMP sensor		Replace.
	5. Defective CKP sensor		Replace.
6. Defective GP sensor	Replace.		
7. Defective IAP sensor	Replace.		
8. Defective ECM	Replace.		
9. TP sensor out of adjustment	Replace.		
10. Defective STP sensor and/or STVA	Replace.		
11. Defective ISC valve	Replace.		

Complaint	Symptom and possible causes	Remedy
<b>Engine lacks power.</b>	<p data-bbox="480 249 1019 275"><b>Defective engine internal/electrical parts</b></p> <ol data-bbox="492 285 1105 835" style="list-style-type: none"> <li data-bbox="492 285 837 310">1. Loss of tappet clearance</li> <li data-bbox="492 321 834 346">2. Weakened valve springs</li> <li data-bbox="492 357 906 382">3. Valve timing out of adjustment</li> <li data-bbox="492 392 902 417">4. Worn piston rings or cylinders</li> <li data-bbox="492 428 805 453">5. Poor seating of valves</li> <li data-bbox="492 464 769 489">6. Fouled spark plugs</li> <li data-bbox="492 499 792 525">7. Incorrect spark plugs</li> <li data-bbox="492 535 802 560">8. Clogged fuel injectors</li> <li data-bbox="492 571 883 596">9. TP sensor out of adjustment</li> <li data-bbox="492 606 883 632">10. Clogged air cleaner element</li> <li data-bbox="492 642 1049 667">11. Imbalancing throttle valve synchronization</li> <li data-bbox="492 678 1101 703">12. Sucking air from throttle valve or vacuum hose</li> <li data-bbox="492 714 781 739">13. Too much engine oil</li> <li data-bbox="492 749 878 774">14. Defective fuel pump or ECM</li> <li data-bbox="492 785 1016 810">15. Defective CKP sensor and ignition coils</li> </ol> <p data-bbox="480 846 932 871"><b>Defective control circuit or sensor</b></p> <ol data-bbox="492 882 1045 1327" style="list-style-type: none"> <li data-bbox="492 882 753 907">1. Low fuel pressure</li> <li data-bbox="492 917 786 942">2. Defective TP sensor</li> <li data-bbox="492 953 789 978">3. Defective IAT sensor</li> <li data-bbox="492 989 805 1014">4. Defective CKP sensor</li> <li data-bbox="492 1024 789 1050">5. Defective GP sensor</li> <li data-bbox="492 1060 792 1085">6. Defective IAP sensor</li> <li data-bbox="492 1096 721 1121">7. Defective ECM</li> <li data-bbox="492 1131 773 1157">8. Defective ISC valve</li> <li data-bbox="492 1167 883 1192">9. TP sensor out of adjustment</li> <li data-bbox="492 1203 1045 1228">10. Imbalanced throttle valve synchronization</li> <li data-bbox="492 1239 967 1264">11. Defective STP sensor and/or STVA</li> <li data-bbox="492 1274 748 1299">12. Defective EXCVA</li> </ol>	<p data-bbox="1159 285 1240 310">Adjust.</p> <p data-bbox="1159 321 1268 346">Replace.</p> <p data-bbox="1159 357 1240 382">Adjust.</p> <p data-bbox="1159 392 1268 417">Replace.</p> <p data-bbox="1159 428 1240 453">Repair.</p> <p data-bbox="1159 464 1370 489">Clean or replace.</p> <p data-bbox="1159 499 1370 525">Adjust or replace.</p> <p data-bbox="1159 535 1268 560">Replace.</p> <p data-bbox="1159 571 1240 596">Adjust.</p> <p data-bbox="1159 606 1268 632">Replace.</p> <p data-bbox="1159 642 1240 667">Adjust.</p> <p data-bbox="1159 678 1414 703">Retighten or replace.</p> <p data-bbox="1159 714 1403 739">Drain out excess oil.</p> <p data-bbox="1159 749 1268 774">Replace.</p> <p data-bbox="1159 785 1268 810">Replace.</p> <p data-bbox="1159 882 1370 907">Repair or replace.</p> <p data-bbox="1159 917 1268 942">Replace.</p> <p data-bbox="1159 953 1268 978">Replace.</p> <p data-bbox="1159 989 1268 1014">Replace.</p> <p data-bbox="1159 1024 1268 1050">Replace.</p> <p data-bbox="1159 1060 1268 1085">Replace.</p> <p data-bbox="1159 1096 1268 1121">Replace.</p> <p data-bbox="1159 1131 1268 1157">Replace.</p> <p data-bbox="1159 1167 1240 1192">Adjust.</p> <p data-bbox="1159 1203 1240 1228">Adjust.</p> <p data-bbox="1159 1239 1268 1264">Replace.</p> <p data-bbox="1159 1274 1268 1299">Replace.</p>

Complaint	Symptom and possible causes	Remedy
<b>Engine overheats</b>	<p><b>Defective engine internal parts</b></p> <ol style="list-style-type: none"> <li>1. Heavy carbon deposit on piston crowns</li> <li>2. Not enough oil in the engine</li> <li>3. Defective oil pump or clogged oil circuit</li> <li>4. Sucking air from intake pipes</li> <li>5. Use incorrect engine oil</li> <li>6. Defective cooling system</li> </ol> <p><b>Lean fuel/air mixture</b></p> <ol style="list-style-type: none"> <li>1. Short-circuited IAP sensor/lead wire</li> <li>2. Short-circuited IAT sensor/lead wire</li> <li>3. Sucking air from intake pipe joint</li> <li>4. Defective fuel injectors</li> <li>5. Defective ECT sensor</li> </ol> <p><b>Other factors</b></p> <ol style="list-style-type: none"> <li>1. Ignition timing is too advanced due to defective timing advance system (ECT sensor, GP sensor, CKP sensor and ECM).</li> </ol>	<p>Clean. Add oil. Replace or clean. Retighten or replace. Change. See radiator section.</p> <p>Repair or replace. Repair or replace. Repair or replace. Replace. Replace.</p> <p>Replace.</p>
<b>Dirty or heavy exhaust smoke</b>	<ol style="list-style-type: none"> <li>1. Too much engine oil in the engine</li> <li>2. Worn piston rings or cylinders</li> <li>3. Worn valve guides</li> <li>4. Scored or scuffed cylinder walls</li> <li>5. Worn valves stems</li> <li>6. Defective stem seal</li> <li>7. Worn oil ring side rails</li> </ol>	<p>Check with inspection window, drain out excess oil. Replace. Replace. Replace. Replace. Replace. Replace.</p>
<b>Slipping clutch</b>	<ol style="list-style-type: none"> <li>1. Weakened clutch springs</li> <li>2. Worn or distorted pressure plates</li> <li>3. Distorted clutch plates or pressure plates</li> <li>4. Clutch release screw out of adjustment</li> </ol>	<p>Replace. Replace. Replace. Adjust</p>
<b>Dragging clutch</b>	<ol style="list-style-type: none"> <li>1. Some clutch spring weakened while others are not.</li> <li>2. Distorted pressure plates or clutch plates</li> <li>3. Clutch release screw out of adjustment</li> </ol>	<p>Replace. Replace. Adjust</p>
<b>Transmission will not shift.</b>	<ol style="list-style-type: none"> <li>1. Broken gearshift cam</li> <li>2. Distorted gearshift forks</li> <li>3. Worn gearshift pawl</li> </ol>	<p>Replace. Replace. Replace.</p>
<b>Transmission will not shift back.</b>	<ol style="list-style-type: none"> <li>1. Broken return spring on shift shaft</li> <li>2. Rubbing or stickily shift shaft</li> <li>3. Distorted or worn gearshift forks</li> </ol>	<p>Replace. Repair or replace. Replace.</p>
<b>Transmission jumps out of gear.</b>	<ol style="list-style-type: none"> <li>1. Worn shifting gears on driveshaft or countershaft</li> <li>2. Distorted or worn gearshift forks</li> <li>3. Weakened stopper spring on gearshift stopper</li> <li>4. Worn gearshift cam plate</li> </ol>	<p>Replace. Replace. Replace. Replace.</p>



**RADIATOR (COOLING SYSTEM)**

<b>Complaint</b>	<b>Symptom and possible causes</b>	<b>Remedy</b>
<b>Engine overheats</b>	<ol style="list-style-type: none"> <li>1. Not enough engine coolant</li> <li>2. Radiator core clogged with dirt or scale</li> <li>3. Faulty cooling fan</li> <li>4. Defective cooling fan relay, or open- or short-circuited</li> <li>5. Defective ECM</li> <li>6. Defective ECT sensor</li> <li>7. Clogged water passage</li> <li>8. Air trapped in the cooling circuit</li> <li>9. Defective water pump</li> <li>10. Use incorrect coolant</li> <li>11. Defective thermostat</li> </ol>	<p>Add coolant.</p> <p>Clean.</p> <p>Repair or replace.</p> <p>Repair or replace.</p> <p>Replace.</p> <p>Replace.</p> <p>Clean.</p> <p>Bleed air.</p> <p>Replace.</p> <p>Replace.</p> <p>Replace.</p>
<b>Engine overcools</b>	<ol style="list-style-type: none"> <li>1. Defective ECT sensor</li> <li>2. Extremely cold weather</li> <li>3. Defective thermostat</li> <li>4. Defective cooling fan relay, or open- or short-circuited</li> <li>5. Defective ECM</li> </ol>	<p>Replace.</p> <p>Put on the radiator cover.</p> <p>Replace.</p> <p>Repair or replace.</p> <p>Replace.</p>

## CHASSIS

Complaint	Symptom and possible causes	Remedy
<b>Heavy steering</b>	<ol style="list-style-type: none"> <li>1. Overtightened steering stem nut</li> <li>2. Broken bearing in steering stem</li> <li>3. Distorted steering stem</li> <li>4. Not enough pressure in tires</li> </ol>	Adjust. Replace. Replace. Adjust.
<b>Wobbly handlebars</b>	<ol style="list-style-type: none"> <li>1. Loss of balance between right and left front forks</li> <li>2. Distorted front fork</li> <li>3. Distorted front axle or crooked tire</li> <li>4. Loose steering stem nut</li> <li>5. Worn or incorrect tire or wrong tire pressure</li> <li>6. Worn bearing/race in steering stem</li> </ol>	Adjust. Repair or replace. Replace. Adjust. Adjust or replace. Replace.
<b>Wobbly front wheel</b>	<ol style="list-style-type: none"> <li>1. Distorted wheel rim</li> <li>2. Worn front wheel bearings</li> <li>3. Defective or incorrect tire</li> <li>4. Loose axle or axle pinch bolt</li> <li>5. Incorrect front fork oil level</li> <li>6. Incorrect front wheel weight balance</li> </ol>	Replace. Replace. Replace. Retighten. Adjust. Adjust.
<b>Front suspension too soft</b>	<ol style="list-style-type: none"> <li>1. Weakened springs</li> <li>2. Not enough fork oil</li> <li>3. Wrong weight fork oil</li> </ol>	Replace. Replenish. Replace.
<b>Front suspension too stiff</b>	<ol style="list-style-type: none"> <li>1. Too viscous fork oil</li> <li>2. Too much fork oil</li> <li>3. Bent front axle</li> </ol>	Replace. Drain excess oil. Replace.
<b>Noisy front suspension</b>	<ol style="list-style-type: none"> <li>1. Not enough fork oil</li> <li>2. Loose bolts on suspension</li> </ol>	Replenish. Retighten.
<b>Wobbly rear wheel</b>	<ol style="list-style-type: none"> <li>1. Distorted wheel rim</li> <li>2. Worn rear wheel bearing or swingarm bearings</li> <li>3. Defective or incorrect tire</li> <li>4. Worn swingarm and rear suspension bearings</li> <li>5. Loose nuts or bolts on rear suspensions</li> </ol>	Replace. Replace. Replace. Replace. Retighten.
<b>Rear suspension too soft</b>	<ol style="list-style-type: none"> <li>1. Weakened spring of shock absorber</li> <li>2. Leakage of oil or gas shock absorber</li> <li>3. Improperly set rear spring pre-load adjuster</li> </ol>	Replace. Replace. Adjust.
<b>Rear suspension too stiff</b>	<ol style="list-style-type: none"> <li>1. Bent shock absorber shaft</li> <li>2. Bent swingarm pivot shaft</li> <li>3. Worn swingarm and rear suspension bearings</li> <li>4. Improperly set rear spring pre-load adjuster</li> </ol>	Replace. Replace. Replace. Adjust.
<b>Noisy rear suspension</b>	<ol style="list-style-type: none"> <li>1. Loose nuts or bolts on rear suspension</li> <li>2. Worn swingarm and suspension bearings</li> </ol>	Retighten. Replace.

## SHAFT DRIVE

Complaint	Symptom and possible causes	Remedy
Noisy shaft drive	<b>Noise seems to come from secondary bevel gear and final bevel gear assemblies.</b> <ol style="list-style-type: none"> <li>Oil level too low</li> <li>Drive and driven bevel gears damaged or worn</li> <li>Excessive backlash</li> <li>Improper tooth contact</li> <li>Damage to bearings</li> </ol>	Refill. (Check oil jet./Replace oil seal.) Replace. Adjust. Adjust. Replace.
	<b>Noise seems to come from propeller shaft area.</b> <ol style="list-style-type: none"> <li>Propeller shaft universal joint damaged</li> <li>Propeller shaft splines damaged or worn</li> <li>Insufficient lubricant</li> <li>Cam dog contacting surface damaged or worn</li> </ol>	Replace. Replace. Refill. (Replace oil seal.) Replace.

## BRAKES

Complaint	Symptom and possible causes	Remedy
Insufficient brake power	<ol style="list-style-type: none"> <li>Leakage of brake fluid from hydraulic system</li> <li>Worn pads</li> <li>Oil adhesion of engaging surface of pads</li> <li>Worn disc</li> <li>Air in hydraulic system</li> <li>Not enough brake fluid in the reservoir</li> </ol>	Repair or replace. Replace. Clean disc and pads. Replace. Bleed air. Replenish.
Brake squeaking	<ol style="list-style-type: none"> <li>Carbon adhesion on pad surface</li> <li>Tilted pad</li> <li>Damaged wheel bearing</li> <li>Loosen front wheel axle or rear wheel axle</li> <li>Worn pads</li> <li>Foreign material in brake fluid</li> <li>Clogged return port of master cylinder</li> </ol>	Repair surface with sandpaper. Correct pad fitting or replace. Replace. Tighten to specified torque. Replace. Replace brake fluid. Disassemble and clean master cylinder.
Excessive brake lever stroke	<ol style="list-style-type: none"> <li>Air in hydraulic system</li> <li>Insufficient brake fluid</li> <li>Improper quality of brake fluid</li> </ol>	Bleed air. Replenish fluid to specified level; bleed air. Replace with correct fluid.
Leakage of brake fluid	<ol style="list-style-type: none"> <li>Insufficient tightening of connection joints</li> <li>Cracked hose</li> <li>Worn piston and/or cup</li> </ol>	Tighten to specified torque. Replace. Replace piston and/or cup.
Brake drags	<ol style="list-style-type: none"> <li>Rusty part</li> <li>Insufficient brake lever or brake pedal pivot lubrication</li> </ol>	Clean and lubricate. Lubricate.







## ELECTRICAL

Complaint	Symptom and possible causes	Remedy
<b>No sparking or poor sparking</b>	<ol style="list-style-type: none"> <li>1. Defective ignition coils</li> <li>2. Defective ignition coil/plug caps</li> <li>3. Defective spark plugs</li> <li>4. Defective CKP sensor</li> <li>5. Defective ECM</li> <li>6. Defective TO sensor</li> <li>7. Open-circuited wiring connections</li> </ol>	<p>Replace.</p> <p>Replace.</p> <p>Replace.</p> <p>Replace.</p> <p>Replace.</p> <p>Replace.</p> <p>Check and repair.</p>
<b>Spark plug soon become fouled with carbon.</b>	<ol style="list-style-type: none"> <li>1. Mixture too rich</li> <li>2. Idling speed set too high</li> <li>3. Incorrect gasoline</li> <li>4. Dirty air cleaner element</li> <li>5. Too cold spark plugs</li> </ol>	<p>Inspect FI system.</p> <p>Adjust throttle valve synchronization and idling speed.</p> <p>Change.</p> <p>Replace.</p> <p>Replace with hot type plug.</p>
<b>Spark plug become fouled too soon.</b>	<ol style="list-style-type: none"> <li>1. Worn piston rings</li> <li>2. Worn piston or cylinders</li> <li>3. Excessive clearance of valve stems in valve guides</li> <li>4. Worn stem oil seal</li> </ol>	<p>Replace.</p> <p>Replace.</p> <p>Replace.</p> <p>Replace.</p>
<b>Spark plug electrodes overheat or burn</b>	<ol style="list-style-type: none"> <li>1. Too hot spark plugs</li> <li>2. Overheated the engine</li> <li>3. Loose spark plugs</li> <li>4. Too lean mixture</li> </ol>	<p>Replace with cold type plugs.</p> <p>Tune up.</p> <p>Retighten.</p> <p>Inspect FI system.</p>
<b>Generator does not charge.</b>	<ol style="list-style-type: none"> <li>1. Open- or short-circuited lead wires, or loose lead connections</li> <li>2. Short-circuited, grounded or open generator coil</li> <li>3. Short-circuited or punctured regulator/rectifier</li> </ol>	<p>Repair or replace or retighten.</p> <p>Replace.</p> <p>Replace.</p>
<b>Generator does charge, but charging rate is below the specification.</b>	<ol style="list-style-type: none"> <li>1. Lead wires tend to get shorted or open-circuited or loosely connected at terminals.</li> <li>2. Grounded or open-circuited generator coil</li> <li>3. Defective regulator/rectifier</li> <li>4. Defective cell plates in the battery</li> </ol>	<p>Repair or retighten.</p> <p>Replace.</p> <p>Replace.</p> <p>Replace the battery.</p>
<b>Generator over-charges</b>	<ol style="list-style-type: none"> <li>1. Internal short-circuit in the battery</li> <li>2. Damaged or defective regulator/rectifier</li> <li>3. Poorly grounded regulator/rectifier</li> </ol>	<p>Replace the battery.</p> <p>Replace.</p> <p>Clean and tighten ground connection.</p>
<b>Unstable charging</b>	<ol style="list-style-type: none"> <li>1. Lead wire insulation frayed due to vibration, resulting in intermittent short-circuiting.</li> <li>2. Internally shorted generator</li> <li>3. Defective regulator/rectifier</li> </ol>	<p>Repair or replace.</p> <p>Replace.</p> <p>Replace.</p>
<b>Starter button is not effective.</b>	<ol style="list-style-type: none"> <li>1. Run down battery</li> <li>2. Defective switch contacts</li> <li>3. Brushes not seating properly on starter motor commutator</li> <li>4. Defective starter relay/starter interlock switch</li> <li>5. Defective main fuse</li> </ol>	<p>Repair or replace.</p> <p>Replace.</p> <p>Repair or replace.</p> <p>Replace.</p> <p>Replace.</p>

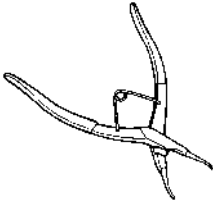
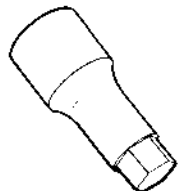
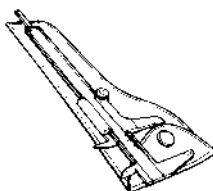
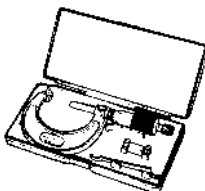
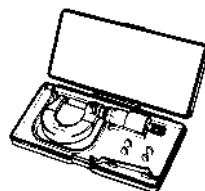
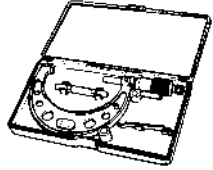

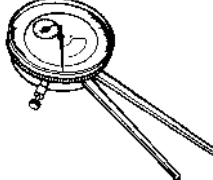

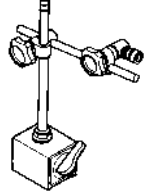
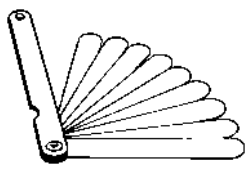
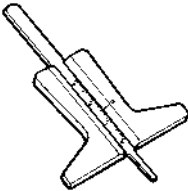
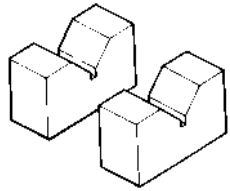

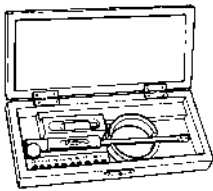
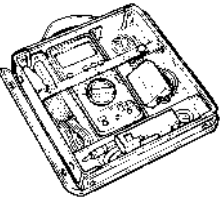
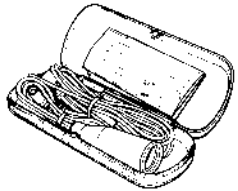
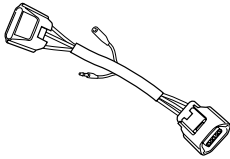
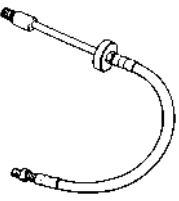
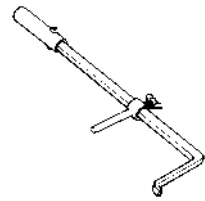

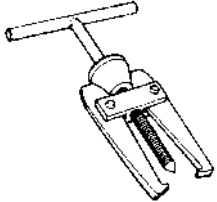
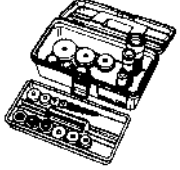

## BATTERY

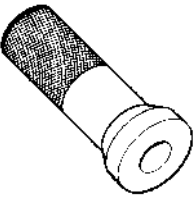
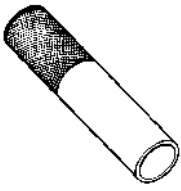

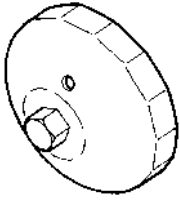
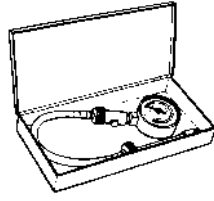
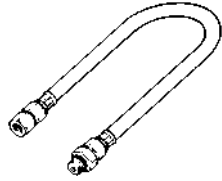
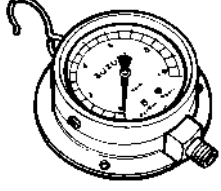
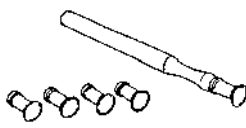
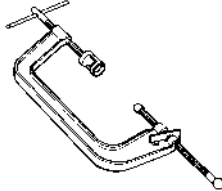
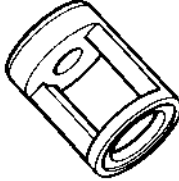

Complaint	Symptom and possible causes	Remedy
<b>“Sulfation”, acidic white powdery substance or spots on surface of cell plates</b>	<ol style="list-style-type: none"> <li>1. Cracked battery case</li> <li>2. Battery has been left in a run-down condition for a long time.</li> </ol>	<p>Replace the battery.</p> <p>Replace the battery.</p>
<b>Battery runs down quickly.</b>	<ol style="list-style-type: none"> <li>1. Trouble in the charging system</li> <li>2. Cell plates have lost much of their active material as a result of overcharging.</li> <li>3. Internal short-circuit in the battery</li> <li>4. Too low battery voltage</li> <li>5. Too old battery</li> </ol>	<p>Check the generator, regulator/rectifier and circuit connections and make necessary adjustments to obtain specified charging operation.</p> <p>Replace the battery and correct the charging system.</p> <p>Replace the battery.</p> <p>Recharge the battery fully.</p> <p>Replace the battery.</p>
<b>Battery “sulfation”</b>	<ol style="list-style-type: none"> <li>1. Incorrect charging rate (When not in use batteries should be checked at least once a month to avoid sulfation.)</li> <li>2. The battery was left unused in a cold climate for too long.</li> </ol>	<p>Replace the battery.</p> <p>Replace the battery if badly sulfated.</p>

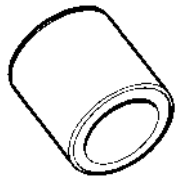

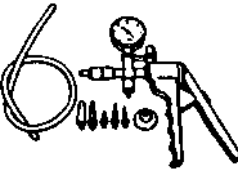
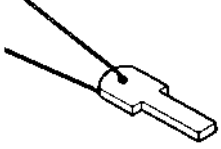

## SPECIAL TOOLS

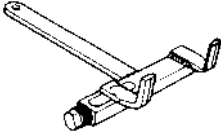
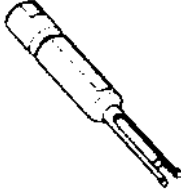
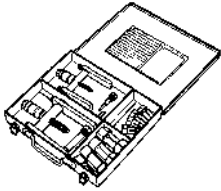
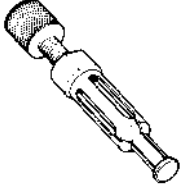
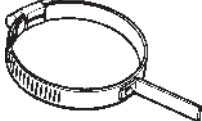
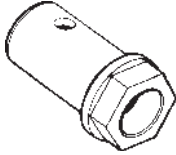
				
<b>09900-06108</b> Snap ring pliers	<b>09900-18740</b> Hexagon socket (24 mm)	<b>09900-20101</b> <b>09900-20102</b> Vernier calipers	<b>09900-20202</b> Micrometer (25 – 50 mm)	<b>09900-20205</b> Micrometer (0 – 25 mm)
				
<b>09900-20210</b> Micrometer (100 – 125 mm)	<b>09900-20602</b> Dial gauge (1/1 000 mm, 1 mm)	<b>09900-20605</b> Dial calipers (1/100 mm, 10 – 34 mm)	<b>09900-20607</b> Dial gauge (1/100 mm, 10 mm)	<b>09900-20701</b> Magnetic stand
				
<b>09900-20803</b> <b>09900-20806</b> Thickness gauge	<b>09900-20805</b> Tire depth gauge	<b>09900-21304</b> V-block set (100 mm)	<b>09900-22301</b> <b>09900-22302</b> Plastigauge	<b>09900-22401 (10 – 18 mm)</b> <b>09900-22403 (18 – 35 mm)</b> Small bore gauge
				
<b>09900-25008</b> Multi circuit tester set	<b>09900-25009</b> Needle pointed probe set	<b>09900-28630</b> TPS test wire harness	<b>09913-10750</b> Adapter	<b>09913-50121</b> Oil seal remover

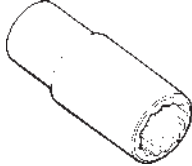
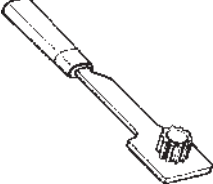
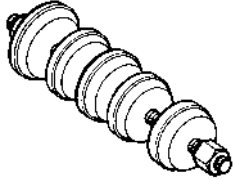
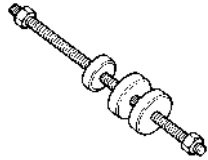
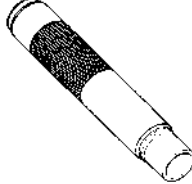
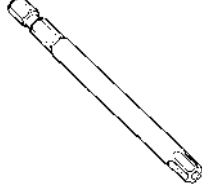
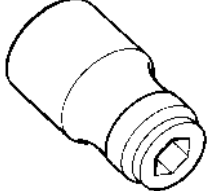
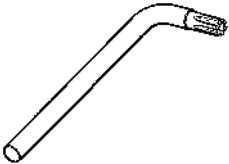
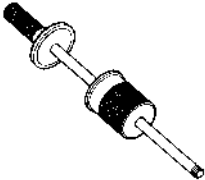
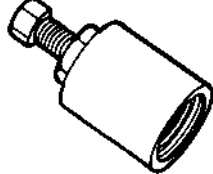
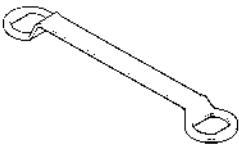

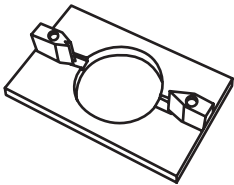
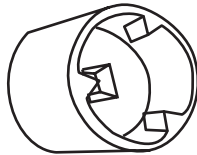
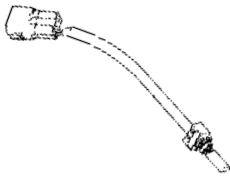
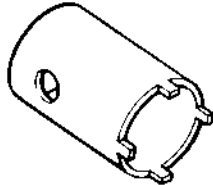
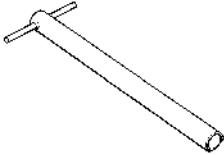
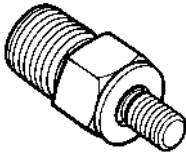
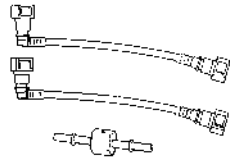
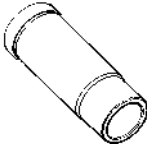
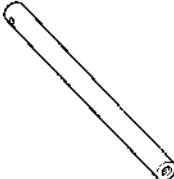
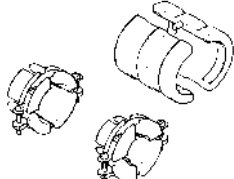
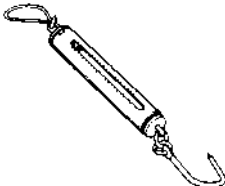
 <p><b>09913-60910</b> Bearing puller</p>	 <p><b>09913-70210</b> Bearing installer set</p>	 <p><b>09913-75821</b> Bearing installer</p>	 <p><b>09913-76010</b> Bearing installer</p>	 <p><b>09913-84510</b> Bearing installer</p>
 <p><b>09915-17410</b> Oil pressure gauge attachment</p>	 <p><b>09915-40610</b> Oil filter wrench</p>	 <p><b>09915-64512</b> Compression gauge set</p>	 <p><b>09915-74511</b> <b>09915-74521</b> Oil pressure gauge hose</p>	 <p><b>09915-77331</b> Meter (for high pressure)</p>
 <p><b>09916-10911</b> Valve lapper set</p>	 <p><b>09916-14510</b> Valve lifter</p>	 <p><b>09916-14910</b> Valve lifter attachment</p>	 <p><b>09916-34542</b> Reamer handle</p>	 <p><b>09916-37810</b> Valve guide reamer</p>
 <p><b>09916-46020</b> Valve guide remover/installer</p>	 <p><b>09916-44940</b> Attachment</p>	 <p><b>09916-84511</b> Tweezers</p>	 <p><b>09917-47011</b> Vacuum pump gauge</p>	 <p><b>09917-62430</b> Chain tensioner lock tool</p>

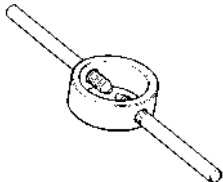
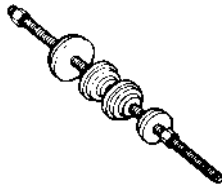
 <p><b>09918-53810</b> Chain tensioner lock tool</p>	 <p><b>09919-28610</b> Sleeve protector</p>	 <p><b>09920-53740</b> Clutch sleeve hub holder</p>	 <p><b>09921-20210</b> Bearing remover</p>	 <p><b>09921-20240</b> Bearing remover set</p>
 <p><b>09923-74511</b> Bearing remover</p>	 <p><b>09924-34510</b> Backlash measur- ing tool (<math>\phi 27 - 50</math>)</p>	 <p><b>09924-41830</b> Bearing retainer wrench</p>	 <p><b>09924-62410</b> Final drive gear bearing holder wrench</p>	 <p><b>09924-62430</b> 22 mm Long socket</p>
 <p><b>09924-64510</b> Final drive gear coupling holder</p>	 <p><b>09924-84510</b> Bearing installer set</p>	 <p><b>09924-84521</b> Bearing installer set</p>	 <p><b>09925-18011</b> Steering bearing installer</p>	 <p><b>09930-11920</b> Torx bit JT40H</p>
 <p><b>09930-11940</b> Bit holder</p>	 <p><b>09930-11950</b> Torx wrench</p>	 <p><b>09930-30104</b> Sliding shaft</p>	 <p><b>09930-30721</b> Rotor remover</p>	 <p><b>09930-44541</b> Rotor holder</p>

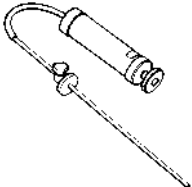
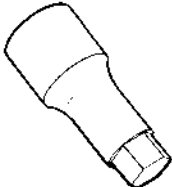
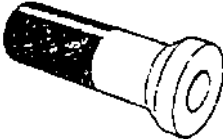
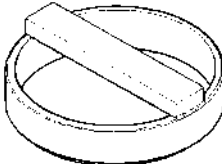
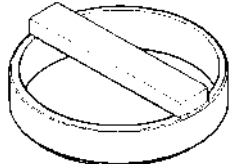
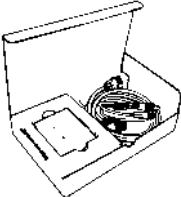
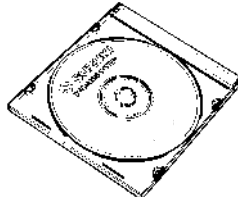
 <p><b>09930-73170</b> Starter torque limiter holder</p>	 <p><b>09930-73180</b> Starter torque limiter socket</p>	 <p><b>09930-82720</b> Mode selection switch</p>	 <p><b>09940-14911</b> Steering stem nut wrench</p>	 <p><b>09940-30221</b> Front fork assembling tool</p>
 <p><b>09940-40211</b> Fuel pressure gauge adaptor</p>	 <p><b>09940-40220</b> Fuel pressure gauge hose attachment</p>	 <p><b>09940-51410</b> Bearing installer</p>	 <p><b>09940-52841</b> Front fork inner rod holder</p>	 <p><b>09940-52861</b> Front fork oil seal installer</p>
 <p><b>09940-92720</b> Spring scale</p>	 <p><b>09940-94922</b> Front fork spring stopper plate</p>	 <p><b>09940-94930</b> Front fork spacer holder</p>	 <p><b>09941-34513</b> Steering race installer</p>	 <p><b>09941-64511</b> Bearing remover</p>
 <p><b>09943-74111</b> Fork oil level gauge</p>	 <p><b>09944-28320</b> Hexagon socket (19 mm)</p>	 <p><b>09951-16080</b> Bearing installer</p>	 <p><b>09951-16310</b> Final gear case oil seal installer</p>	 <p><b>09951-17010</b> Final driven gear bearing installer</p>
 <p><b>09904-41010</b> SDS Set</p>	 <p><b>99565-01010-007</b> CD-ROM Ver. 7</p>			

**NOTE:**

When order the special tool, please confirm whether it is available or not.

## TIGHTENING TORQUE

### ENGINE

ITEM		N-m	kgf-m	lb-ft	
Cylinder head cover bolt		11	1.1	8.0	
Cylinder head cover cap bracket bolt		11	1.1	8.0	
Cylinder head bolt	M: 6	11	1.1	8.0	
	M: 8	26	2.6	19.0	
	M: 10	Initial	25	2.5	18.0
		Final	42	4.2	30.5
Cylinder nut		13	1.3	9.5	
Cylinder head plug (Water jacket plug)		26	2.6	19.0	
Camshaft housing bolt		11	1.1	8.0	
Sprocket cam chain drive bolt		85	8.5	61.5	
Cam chain tension No.1 adjuster bolt		10	1.0	7.0	
Cam chain tension No.2 adjuster bolt		10	1.0	7.0	
Cam chain tension adjuster cap bolt		23	2.3	16.5	
Cam chain tensioner bolt (No.1 & No.2)		18	1.8	13.0	
Cam chain tensioner No.2 nut		10	1.0	7.0	
Cam chain guide No.1 bolt		18	1.8	13.0	
Exhaust pipe bolt		23	2.3	16.5	
Muffler mounting bolt and nut		23	2.3	16.5	
Oxygen sensor (For E-02, 19, 24)	#1 & #2	48	4.8	34.5	
Spark plug		11	1.1	8.0	
Primary driven gear bolt		95	9.5	68.5	
Starter clutch bolt		25	2.5	18.0	
Crank balancer drive gear bolt		24	2.4	17.5	
Crank balancer driven gear bolt	M: 6	10	1.0	7.0	
	M: 8	25	2.5	18.0	
Conrod bearing cap bolt	Initial	35	3.5	25.5	
	Final	After tightening to the above torque, tighten 1/4 of a turn (90°)			
Oil drain plug		23	2.3	16.5	
Crankcase bolt	M: 6	11	1.1	8.0	
	M: 8	26	2.6	19.0	
	M: 10	Initial	30	3.0	21.5
		Final	50	5.0	36.0
Oil gallery plug	M: 6	10	1.0	7.0	
	M: 10	16	1.6	11.5	
	M: 12	21	2.1	15.0	
	M: 14	25	2.5	18.0	
	M: 16	35	3.5	25.5	
Oil cooler union bolt		70	7.0	50.5	
Oil pressure switch		14	1.4	10.0	
Oil pressure switch lead wire screw		1.5	0.15	1.0	
Clutch sleeve hub nut		95	9.5	68.5	

ITEM	N-m	kgf-m	lb-ft
Gearshift cam stopper plate bolt	13	1.3	9.5
Gearshift arm stopper bolt	19	1.9	13.5
Gearshift cam stopper bolt	10	1.0	7.0
Gearshift lever shaft	50	5.0	36.0
Gearshift fork shaft retainer plug	35	3.5	25.5
Generator cover plug	16	1.6	11.5
Generator rotor bolt	160	16.0	115.5
Generator stator bolt	11	1.1	8.0
Starter motor bolt	6	0.6	4.5
Starter motor lead wire nut	6	0.6	4.5
Generator lead wire clamp bolt	11	1.1	8.0
Gear position switch bolt	6.5	0.65	4.5
Speed sensor bolt	10	1.0	7.0
Engine oil drain plug	23	2.3	16.5
Oil filter	20	2.0	14.5
Engine mounting bracket bolt (Rear)	23	2.3	16.5
Engine mounting nut	55	5.5	40.0

## DRIVELINE/AXLE

ITEM	N-m	kgf-m	lb-ft
Secondary drive gear bolt	160	16.0	115.5
Secondary driven bearing stopper	105	10.5	76.0
Secondary driven gear coupling nut	95	9.5	68.5
Secondary driven gear case bolt	26	2.6	19.0
Secondary driven gear bearing housing bolt	28	2.8	20.0
Final gear case nut	40	4.0	29.0
Final drive gear coupling nut	100	10.0	72.5
Final drive bearing stopper	110	11.0	79.5
Final driven gear bearing case bolt	M: 8	23	16.5
	M: 10	50	36.0
Final gear case oil drain plug	23	2.3	16.5

## FI SYSTEM AND INTAKE AIR SYSTEM

ITEM	N-m	kgf-m	lb-ft
CKP sensor mounting bolt	6.5	0.65	4.5
Fuel pump mounting bolt	10	1.0	7.0
TPS and STPS mounting screw	3.5	0.35	2.5
Fuel delivery pipe mounting screw	5	0.5	3.5
EXCVA pulley mounting bolt	5	0.5	3.5

## COOLING SYSTEM

ITEM	N-m	kgf-m	lb-ft
Impeller securing bolt	8	0.8	6.0
Water pump mounting bolt	10	1.0	7.0
ECT sensor	18	1.8	13.0

**CHASSIS**

ITEM	N·m	kgf·m	lb·ft
Handlebar clamp bolt	23	2.3	16.5
Handlebar holder bolt	85	8.5	61.5
Handlebar bracket bolt	23	2.3	16.5
Front fork upper and lower clamp bolt	23	2.3	16.5
Front fork cap bolt	23	2.3	16.5
Front fork damper rod bolt	40	4.0	29.0
Front fork inner rod lock nut	15	1.5	11.0
Steering stem head nut	90	9.0	65.0
Front axle	100	10.0	72.5
Front axle pinch bolt	23	2.3	16.5
Brake disc bolt (Front & Rear)	23	2.3	16.5
Front brake caliper pad mounting pin	15	1.5	11.0
Front brake caliper housing bolt	22	2.2	16.0
Rear brake caliper bracket mounting bolt	80	8.0	58.0
Brake caliper mounting bolt (Front & Rear)	39	3.9	28.0
Brake caliper air bleeder valve (Front & Rear)	7.5	0.75	5.5
Brake hose union bolt (Front & Rear)	23	2.3	16.5
Brake master cylinder mounting bolt (Front & Rear)	10	1.0	7.0
Brake pedal boss bolt	16	1.6	11.5
Frame down tube bolt (Front & Rear)	50	5.0	36.0
Seat rail bolt	50	5.0	36.0
License light	5	0.5	3.5
Front footrest bolt RH	60	6.0	43.5
Front footrest bolt LH	50	5.0	36.0
Swingarm pivot shaft	100	10.0	72.5
Rear cushion lever nut (Upper)	110	11.0	79.5
Rear cushion lever nut (Lower)	85	8.5	61.5
Rear cushion rod nut	110	11.0	79.5
Rear shock absorber nut (Front & Rear)	45	4.5	32.5
Rear axle nut (For E-03, 28, 33)	100	10.0	72.5
Rear axle nut (For others)	110	11.0	79.5
Rear master cylinder rod lock nut	18	1.8	13.0

## TIGHTENING TORQUE CHART

For other nuts and bolts not listed in the preceding page, refer to this chart:

Bolt Diameter Ⓐ (mm)	Conventional or "4" marked bolt			"7" marked bolt		
	N·m	kgf·m	lb·ft	N·m	kgf·m	lb·ft
4	1.5	0.15	1.0	2.3	0.23	1.5
5	3	0.3	2.0	4.5	0.45	3.0
6	5.5	0.55	4.0	10	1.0	7.0
8	13	1.3	9.5	23	2.3	16.5
10	29	2.9	21.0	50	5.0	36.0
12	45	4.5	32.5	85	8.5	61.5
14	65	6.5	47.0	135	13.5	97.5
16	105	10.5	76.0	210	21.0	152.0
18	160	16.0	115.5	240	24.0	173.5



Conventional bolt

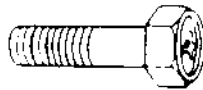

"4" marked bolt



"7" marked bolt



## SERVICE DATA

### VALVE + GUIDE

Unit: mm (in)

ITEM	STANDARD		LIMIT
Valve diam.	IN.	42 (1.65)	—
	EX.	38 (1.50)	—
Tappet clearance (when cold)	IN.	0.09 – 0.16 (0.004 – 0.006)	—
	EX.	0.20 – 0.30 (0.008 – 0.012)	—
Valve guide to valve stem clearance	IN.	0.010 – 0.037 (0.0004 – 0.0015)	—
	EX.	0.030 – 0.057 (0.0012 – 0.0022)	—
Valve guide I.D.	IN. & EX.	6.000 – 6.012 (0.2362 – 0.2367)	—
Valve stem O.D.	IN.	5.975 – 5.990 (0.2352 – 0.2358)	—
	EX.	5.955 – 5.970 (0.2344 – 0.2350)	—
Valve stem deflection	IN. & EX.	—	0.35 (0.014)
Valve stem runout	IN. & EX.	—	0.05 (0.002)
Valve head thickness	IN. & EX.	—	0.5 (0.02)
Valve seat width	IN.	1.1 – 1.3 (0.043 – 0.051)	—
	EX.	1.4 – 1.6 (0.055 – 0.063)	—
Valve head radial runout	IN. & EX.	—	0.03 (0.001)
Valve spring free length	IN. & EX.	—	40.5 (1.60)
Valve spring tension	IN. & EX.	197 – 227 N (20.1 – 23.1 kgf, 44.3 – 51.0 lbs) at length 36.6 mm (1.44 in)	—

## CAMSHAFT + CYLINDER HEAD

Unit: mm (in)

ITEM	STANDARD		LIMIT
Cam height	IN.	40.880 – 40.930 (1.6094 – 1.6114)	40.580 (1.5976)
	EX.	40.880 – 40.930 (1.6094 – 1.6114)	40.580 (1.5976)
Camshaft journal oil clearance	IN. & EX.	0.032 – 0.066 (0.0013 – 0.0026)	0.150 (0.0059)
Camshaft journal holder I.D.	IN. & EX.	24.012 – 24.025 (0.9454 – 0.9459)	—
Camshaft journal O.D.	IN. & EX.	23.959 – 23.980 (0.9433 – 0.9441)	—

ITEM	STANDARD		LIMIT
Camshaft runout	IN. & EX.	—	0.10 (0.004)
Cam chain pin (at arrow "3")	18th pin		—
Cylinder head distortion	—		0.05 (0.002)

**CYLINDER + PISTON + PISTON RING**

Unit: mm (in)

ITEM	STANDARD		LIMIT
Compression pressure (Automatic de-comp. actuated)	1 100 – 1 500 kPa (11.0 – 15.0 kgf/cm <sup>2</sup> , 156 – 213 psi)		800 kPa (8.0 kgf/cm <sup>2</sup> , 114 psi)
Compression pressure difference	—		200 kPa (2.0 kgf/cm <sup>2</sup> , 28 psi)
Piston to cylinder clearance	0.018 – 0.043 (0.0007 – 0.0017)		0.120 (0.0047)
Cylinder bore	112.000 – 112.015 (4.4094 – 4.4100)		Nicks or Scratches
Piston diam.	111.967 – 111.983 (4.4081 – 4.4088) Measure at 10 mm (0.4 in) from the skirt end.		111.880 (4.4047)
Cylinder distortion	—		0.05 (0.002)
Piston ring free end gap	1st	Approx. 15.7 (0.62)	12.6 (0.50)
	2nd	Approx. 14.5 (0.57)	11.6 (0.46)
Piston ring end gap	1st	0.10 – 0.25 (0.004 – 0.010)	0.50 (0.020)
	2nd	0.10 – 0.25 (0.004 – 0.010)	0.50 (0.020)
Piston ring to groove clearance	1st	—	0.180 (0.0071)
	2nd	—	0.150 (0.0059)
Piston ring groove width	1st	0.93 – 0.95 (0.0366 – 0.0374)	—
		1.55 – 1.57 (0.0610 – 0.0618)	—
	2nd	1.21 – 1.23 (0.0476 – 0.0484)	—
	Oil	2.51 – 2.53 (0.0988 – 0.0996)	—
Piston ring thickness	1st	0.86 – 0.91 (0.034 – 0.036)	—
		1.38 – 1.40 (0.054 – 0.055)	—
	2nd	1.17 – 1.19 (0.046 – 0.047)	—
Piston pin bore I.D.	23.002 – 23.008 (0.9056 – 0.9058)		23.030 (0.9067)
Piston pin O.D.	22.995 – 23.000 (0.9053 – 0.9055)		22.980 (0.9047)

**CONROD + CRANKSHAFT**

Unit: mm (in)

ITEM	STANDARD	LIMIT
Conrod small end I.D.	23.010 – 23.018 (0.9059 – 0.9062)	23.040 (0.9071)
Conrod big end side clearance	0.100 – 0.200 (0.0039 – 0.0078)	0.30 (0.012)
Conrod big end width	23.95 – 24.00 (0.943 – 0.945)	—
Crank pin width	24.10 – 24.15 (0.949 – 0.951)	—
Conrod big end oil clearance	0.032 – 0.056 (0.0013 – 0.0022)	0.080 (0.0031)
Crank pin O.D.	54.976 – 55.000 (2.1644 – 2.1654)	—
Crankshaft journal oil clearance	0.016 – 0.034 (0.0006 – 0.0013)	0.080 (0.0031)
Crankshaft journal O.D.	54.982 – 55.000 (2.1646 – 2.1654)	—
Crankshaft thrust bearing thickness	2.250 – 2.550 (0.0886 – 0.1004)	—
Crankshaft thrust clearance	0.100 – 0.200 (0.0039 – 0.0079)	—
Crankshaft runout	—	0.05 (0.002)

**OIL PUMP**

ITEM	STANDARD	LIMIT
Oil pressure (at 60 °C, 140 °F)	Above 400 kPa (4.0 kgf/cm <sup>2</sup> , 57 psi) Below 700 kPa (7.0 kgf/cm <sup>2</sup> , 100 psi) at 3 000 r/min	—

**CLUTCH**

Unit: mm (in)

ITEM	STANDARD	LIMIT
Clutch cable play	10 – 15 (0.4 – 0.6)	—
Clutch release screw	1 turn back	—
Drive plate thickness	No. 1	3.52 – 3.68 (0.139 – 0.145)
	No. 2	1.92 – 2.08 (0.076 – 0.082)
Driven plate thickness	No. 1	2.82 – 2.98 (0.111 – 0.117)
	No. 2	3.32 – 3.48 (0.131 – 0.137)
Driven plate claw width	No. 1 & No. 2	7.96 – 8.15 (0.313 – 0.321)
Driven plate distortion	—	0.10 (0.004)
Clutch spring free length	51.3 (2.02)	48.8 (1.92)

**THERMOSTAT + RADIATOR + FAN + COOLANT**

ITEM	STANDARD		LIMIT
Thermostat valve opening temperature	Approx. 88 °C (190 °F)		—
Thermostat valve lift	Over 8.0 mm (0.31 in) at 100 °C (212 °F)		—
Engine coolant temperature sensor resistance	20 °C (68 °F)	Approx. 2.45 kΩ	—
	50 °C (122 °F)	Approx. 0.811 kΩ	—
	80 °C (176 °F)	Approx. 0.318 kΩ	—
	110 °C (230 °F)	Approx. 0.142 kΩ	—
Radiator cap valve opening pressure	93 – 123 kPa (0.93 – 1.23 kgf/cm <sup>2</sup> , 13.2 – 17.5 psi)		—
Cooling fan operating temperature	OFF → ON	Approx. 105 °C (221 °F)	—
	ON → OFF	Approx. 100 °C (212 °F)	—
Engine coolant type	Use an anti-freeze/coolant compatible with aluminum radiator, mixed with distilled water only, at the ratio of 50:50.		—
Engine coolant	Reservoir tank side	Approx. 250 ml (0.3/0.2 US/Imp qt)	—
	Engine side	Approx. 2 450 ml (2.6/2.2 US/Imp qt)	—

**DRIVE TRAIN**

Unit: mm (in) Expect ratio

ITEM	STANDARD	LIMIT	
Primary reduction ratio	1.757 (58/33)	—	
Secondary reduction ratio	1.058 (18/17)	—	
Final reduction ratio	2.666 (32/12)	—	
Gear ratio	Low	2.187 (35/16)	—
	2nd	1.400 (28/20)	—
	3rd	1.038 (27/26)	—
	4th	0.827 (24/29)	—
	Top	0.685 (24/35)	—
Shift fork to groove clearance	0.1 – 0.3 (0.004 – 0.012)	0.50 (0.020)	
Shift fork groove width	5.0 – 5.1 (0.197 – 0.201)	—	
Shift fork thickness	4.8 – 4.9 (0.189 – 0.193)	—	
Gearshift lever height	45 – 55 (1.8 – 2.2)	—	

**DRIVELINE/AXLE**

Unit: mm (in)

ITEM	STANDARD/SPECIFICATION	LIMIT
Secondary bevel gear backlash	0.03 – 0.15 (0.001 – 0.006)	—
Final bevel gear backlash	0.08 – 0.16 (0.003 – 0.006)	—
Damper spring free length	—	64.6 (2.54)
Final gear oil type	Hypoide gear oil SAE #90, API grade GL-5	—
Final gear oil capacity	200 – 220 ml (6.8/7.0 – 7.4/7.7 US/lmp oz)	—

**INJECTOR + FUEL PUMP + FUEL PRESSURE REGULATOR**

ITEM	SPECIFICATION	NOTE
Injector resistance	11 – 13 $\Omega$ at 23 °C (73 °F)	
Fuel pump discharge amount	168 ml and more (5.7/5.9 US/lmp oz) for 10 seconds at 300 kPa (3.0 kgf/cm <sup>2</sup> , 43 psi)	
Fuel pressure regulator operating set pressure	Approx. 300 kPa (3.0 kgf/cm <sup>2</sup> , 43 psi)	

**FI-SENSORS**

ITEM	SPECIFICATION		NOTE
CKP sensor resistance	190 – 290 $\Omega$		
CKP sensor peak voltage	1.5 V and more		When cranking
IAP sensor input voltage (F & R)	4.5 – 5.5 V		
IAP sensor output voltage (F & R)	Approx. 2.6 V at idle speed		
TP sensor input voltage	4.5 – 5.5 V		
TP sensor resistance	Closed	Approx. 1.1 k $\Omega$	
	Opened	Approx. 4.3 k $\Omega$	
TP sensor output voltage	Closed	Approx. 1.1 V	
	Opened	Approx. 4.3 V	
ECT sensor input voltage	4.5 – 5.5 V		
ECT sensor output voltage	0.15 – 4.84 V		
ECT sensor resistance	Approx. 2.45 k $\Omega$ at 20 °C (68 °F)		
IAT sensor input voltage	4.5 – 5.5 V		
IAT sensor output voltage	0.15 – 4.84 V		
IAT sensor resistance	Approx 2.45 k $\Omega$ at 20 °C (68 °F)		
TO sensor resistance	16.5 – 22.3 k $\Omega$		
TO sensor voltage	Normal	0.4 – 1.4 V	
	Leaning	3.7 – 4.4 V	When leaning 65°
GP switch voltage	0.6 V and more		From 1st to top
Injector voltage	Battery voltage		
Ignition coil primary peak voltage	250 V and more		When cranking
Ignition coil/Plug cap primary peak voltage	80 V and more		When cranking
STP sensor input voltage	4.5 – 5.5 V		
STP sensor resistance	Closed	Approx. 0.6 k $\Omega$	
	Opened	Approx. 4.2 k $\Omega$	

ITEM	SPECIFICATION		NOTE
STP sensor output voltage	Closed	Approx. 0.6 V	
	Opened	Approx. 4.2 V	
STV actuator resistance	Approx. 7 $\Omega$		
EXCVA position sensor input voltage	4.5 – 5.5 V		
EXCVA position sensor resistance	Approx. 3.1 k $\Omega$		At adjustment position
EXCVA position sensor output voltage	Closed	0.5 – 1.5 V	
	Opened	3.5 – 4.5 V	
Heated oxygen sensor output voltage	0.4 V and less at idle speed		E-02, 19, 24
	0.6 V and more at 3 000 r/min		E-02, 19, 24
Heated oxygen sensor resistance	4.0 – 5.5 $\Omega$ at 23 °C (73.4 °F)		E-02, 19, 24
PAIR solenoid valve resistance	18 – 22 $\Omega$ at 20 – 30 °C (68 – 86 °F)		

## THROTTLE BODY

ITEM	SPECIFICATION
I.D. No.	48G1 (For E-33), 48G0 (Others)
Bore size	56 mm
Idle r/min	900 $\pm$ 100 r/min/Warmed engine
Throttle cable play	2.0 – 4.0 mm (0.08 – 0.16 in)

## ELECTRICAL

Unit: mm (in)

ITEM	SPECIFICATION		NOTE
Firing order	1-2		
Spark plug	Type	NGK: CR8EK DENSO: U24ETR	
	Gap	0.6 – 0.7 (0.024 – 0.028)	
Spark performance	Over 8 (0.3) at 1 atm.		
CKP sensor resistance	190 – 290 $\Omega$		BI – G
Ignition coil resistance	Primary	1.8 – 3.0 $\Omega$	$\oplus$ tap – $\ominus$ tap
	Secondary	16 – 26 k $\Omega$	$\ominus$ tap – Plug cap
Ignition coil/Plug cap resistance	Primary	1.1 – 1.9 $\Omega$	$\oplus$ tap – $\ominus$ tap
	Secondary	10.8 – 16.2 k $\Omega$	Plug cap – $\ominus$ tap
CKP sensor peak voltage	1.5 V and more		$\oplus$ BI $\ominus$ G
Ignition coil primary peak voltage	250 V and more		Front $\oplus$ : G $\ominus$ : Ground Rear $\oplus$ : Y $\ominus$ : Ground
Ignition coil/Plug cap primary peak voltage	80 V and more		Front $\oplus$ : B $\ominus$ : Ground Rear $\oplus$ : W/BI $\ominus$ : Ground
Generator coil resistance	0.2 – 1.5 $\Omega$		B – B
Generator Max. output	Approx. 400 W at 5 000 r/min		

ITEM		SPECIFICATION		NOTE
Generator no-load voltage (When engine is cold)		70 V (AC) and more at 5 000 r/min		
Regulated voltage		14.0 – 15.5 V at 5 000 r/min		
Starter relay resistance		3 – 6 $\Omega$		
Battery	Type designation	FTZ16-BS		
	Capacity	12 V 64.8 kC (18 Ah)/10 HR		
Fuse size	Headlight	HI	10 A	
		LO	10 A	
	Fuel	10 A		
	Ignition	15 A		
	Turn signal	15 A		
	Fan motor	15 A		
	Main	30 A		
Starter motor brush length		Standard	12.5 (0.49)	
		Limit	6.0 (0.24)	

**WATTAGE**

Unit: W

ITEM		SPECIFICATION	
		E-03, 28, 33	E-02, 19, 24
Headlight	HI	60	←
	LO	55	←
Position light			5
Brake light/Taillight		LED	←
Front turn signal light/Position light		21/5	
Front turn signal light			21
Rear turn signal light		21	←
Speedometer		LED	←
Tachometer		LED	←
Turn signal indicator light		LED	←
High beam indicator light		LED	←
Neutral indicator light		LED	←
Fuel level indicator light		LED	←
Coolant temperature/Oil pressure indicator light		LED	←
FI indicator light		LED	←
License light		5	←



**BRAKE + WHEEL**

Unit: mm (in)

ITEM		STANDARD		LIMIT
Rear brake pedal height		25 – 35 (1.0 – 1.4)		—
Brake disc thickness	Front	5.0 ± 0.2 (0.197 ± 0.008)		4.5 (0.18)
	Rear	7 <sup>0</sup> <sub>-0.4</sub> (0.276 <sup>0</sup> <sub>-0.016</sub> )		6.3 (0.25)
Brake disc runout (Front & Rear)		—		0.30 (0.012)
Master cylinder bore	Front	15.870 – 15.913 (0.6248 – 0.6265)		—
	Rear	14.000 – 14.043 (0.5512 – 0.5529)		—
Master cylinder piston diam.	Front	15.827 – 15.854 (0.6231 – 0.6242)		—
	Rear	13.957 – 13.984 (0.5495 – 0.5506)		—
Brake caliper cylinder bore	Leading	Front	30.280 – 30.356 (1.1921 – 1.1951)	—
	Trailing		34.010 – 34.086 (1.3390 – 1.3420)	—
	Leading & Trailing	Rear	30.230 – 30.306 (1.1902 – 1.1931)	—
Brake caliper piston diam.	Leading	Front	30.150 – 30.200 (1.1870 – 1.1890)	—
	Trailing		33.884 – 33.934 (1.3340 – 1.3360)	—
	Leading & Trailing	Rear	30.150 – 30.200 (1.1870 – 1.1890)	—
Brake fluid type		DOT 4		—
Wheel rim runout (Front & Rear)	Axial	—		2.0 (0.08)
	Radial	—		2.0 (0.08)
Wheel axle runout	Front	—		0.25 (0.010)
	Rear	—		0.25 (0.010)
Wheel rim size	Front	18M/C × MT 3.50		—
	Rear	18M/C × MT 8.50		—
Tire size	Front	130/70R18M/C 63V, tubeless		—
	Rear	240/40R18M/C 79V, tubeless		—
Tire type	Front	DUNLOP: D221FA		—
	Rear	DUNLOP: D221		—
Tire tread depth	Front	—		1.6 (0.06)
	Rear	—		2.0 (0.08)

**SUSPENSION**

Unit: mm (in)

ITEM	STANDARD	LIMIT
Front fork stroke	130 (5.1)	—
Front fork spring free length	399 (15.7)	391 (15.4)
Front fork inner tube O.D.	46 (1.8)	—
Front fork oil level (without spring, inner tube fully compressed)	133 (5.2)	—
Front fork oil type	SUZUKI FORK OIL L01 or an equivalent fork oil	—
Front fork oil capacity (each leg)	684 ml (23.1/24.1 US/Imp oz)	—
Rear shock absorber spring adjuster	4/7	—
Rear wheel travel	118 (4.6)	—
Swingarm pivot shaft runout	—	0.3 (0.01)

**TIRE PRESSURE**

COLD INFLATION TIRE PRESSURE	SOLO RIDING			DUAL RIDING		
	kPa	kgf/cm <sup>2</sup>	psi	kPa	kgf/cm <sup>2</sup>	psi
FRONT	250	2.50	36	250	2.50	36
REAR	290	2.90	42	290	2.90	42

**FUEL + OIL**

ITEM	SPECIFICATION	NOTE
Fuel type	Use only unleaded gasoline of at least 90 pump octane (R/2 + M/2). Gasoline containing MTBE (Methyl Tertiary Butyl Ether), less than 10% ethanol, or less than 5% methanol with appropriate cosolvents and corrosion inhibitor is permissible.	E-03, 28, 33
	Gasoline used should be graded 95 octane or higher. An unleaded gasoline is recommended.	The others
Fuel tank capacity	18.5 L (4.9/4.1 US/Imp gal)	E-33
	19.5 L (5.2/4.3 US/Imp gal)	The others
Engine oil type	SAE 10W-40, API SF/SG or SH/SJ with JASO MA	
Engine oil capacity	Change	3 400 ml (3.6/3.0 US/Imp qt)
	Filter change	3 600 ml (3.8/3.2 US/Imp qt)
	Overhaul	4 700 ml (5.0/4.1 US/Imp qt)

# WIRING HARNESS, CABLE AND HOSE ROUTING

## WIRING HARNESS ROUTING

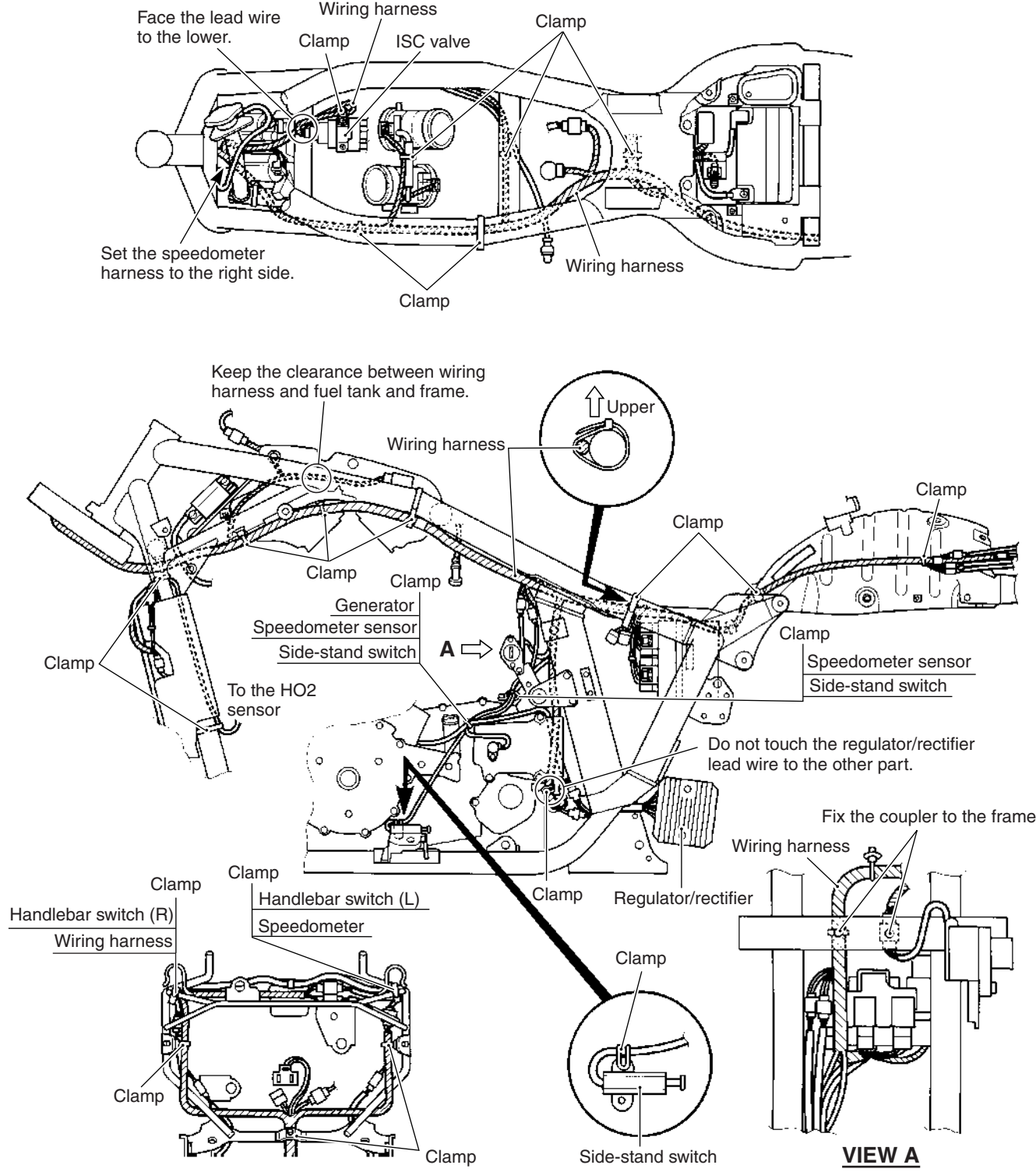

Pass the handlebar switch lead wire  
upper the brake switch coupler.

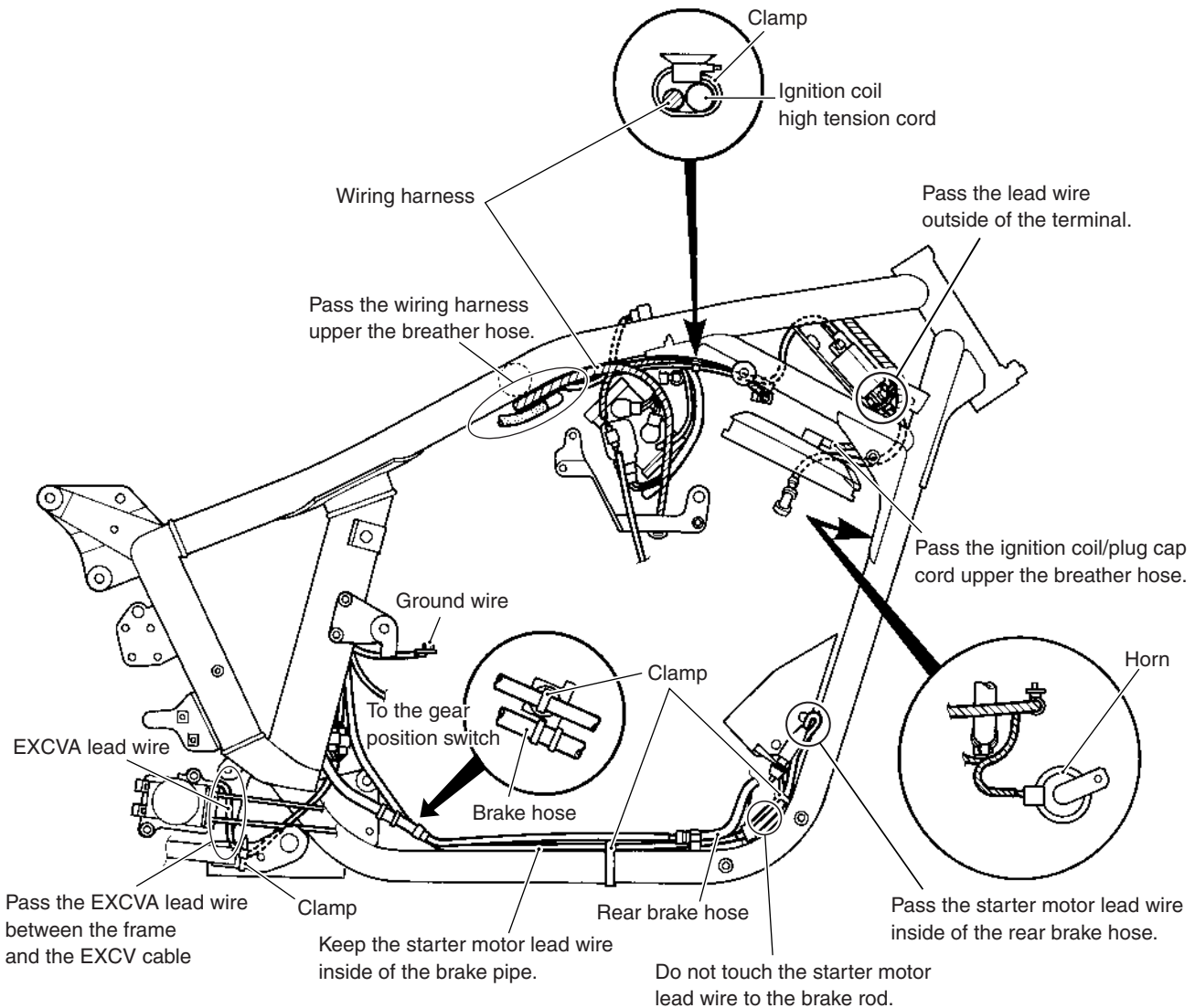
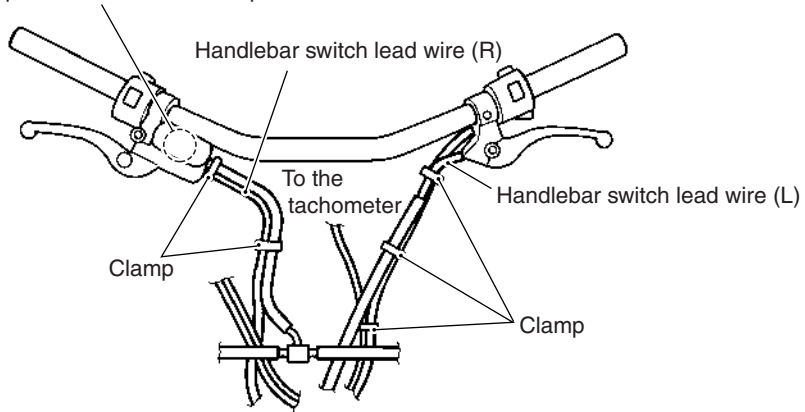

# ENGINE ELECTRICAL PARTS LEAD WIRE ROUTING

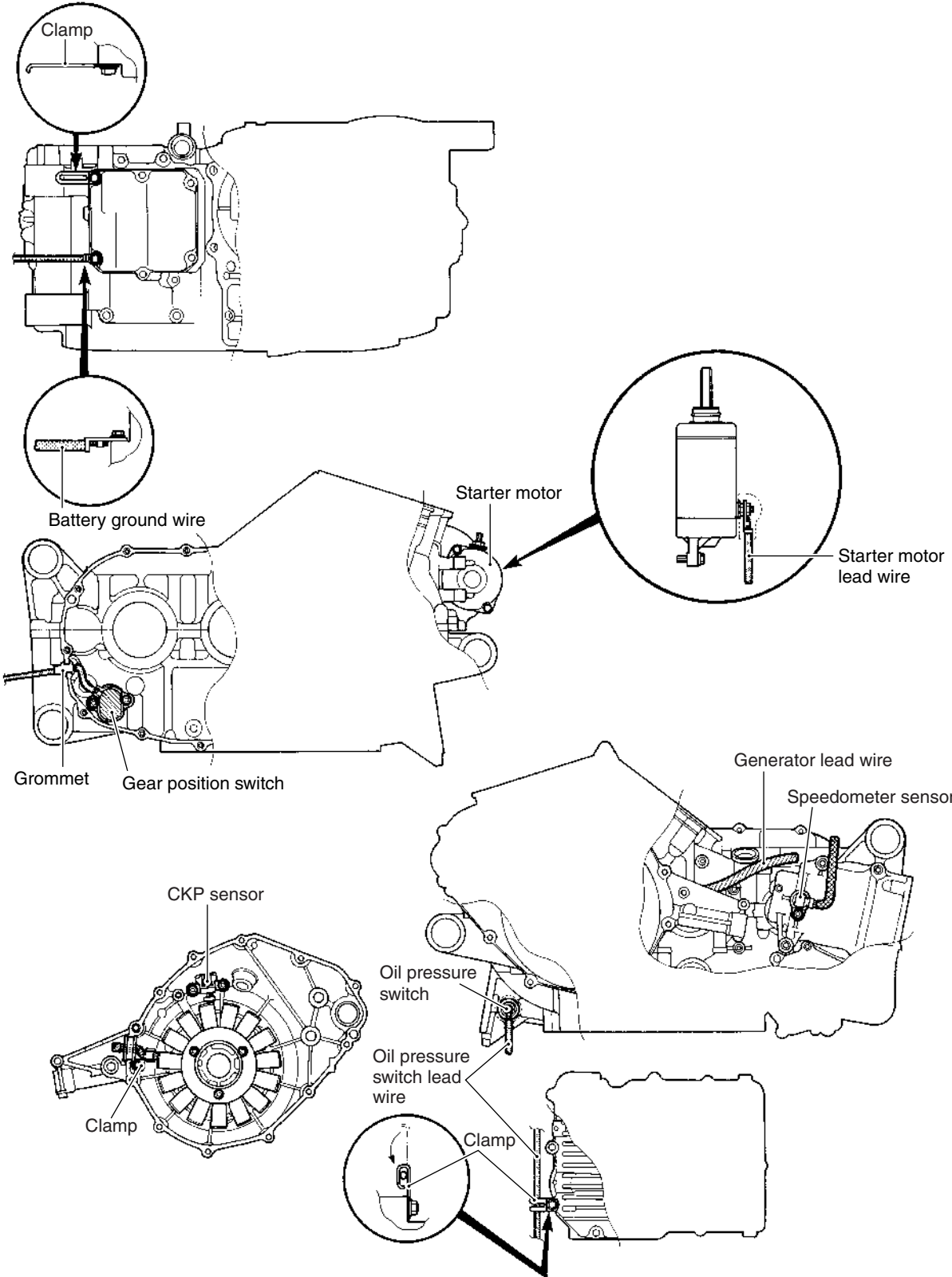

# CABLE ROUTING

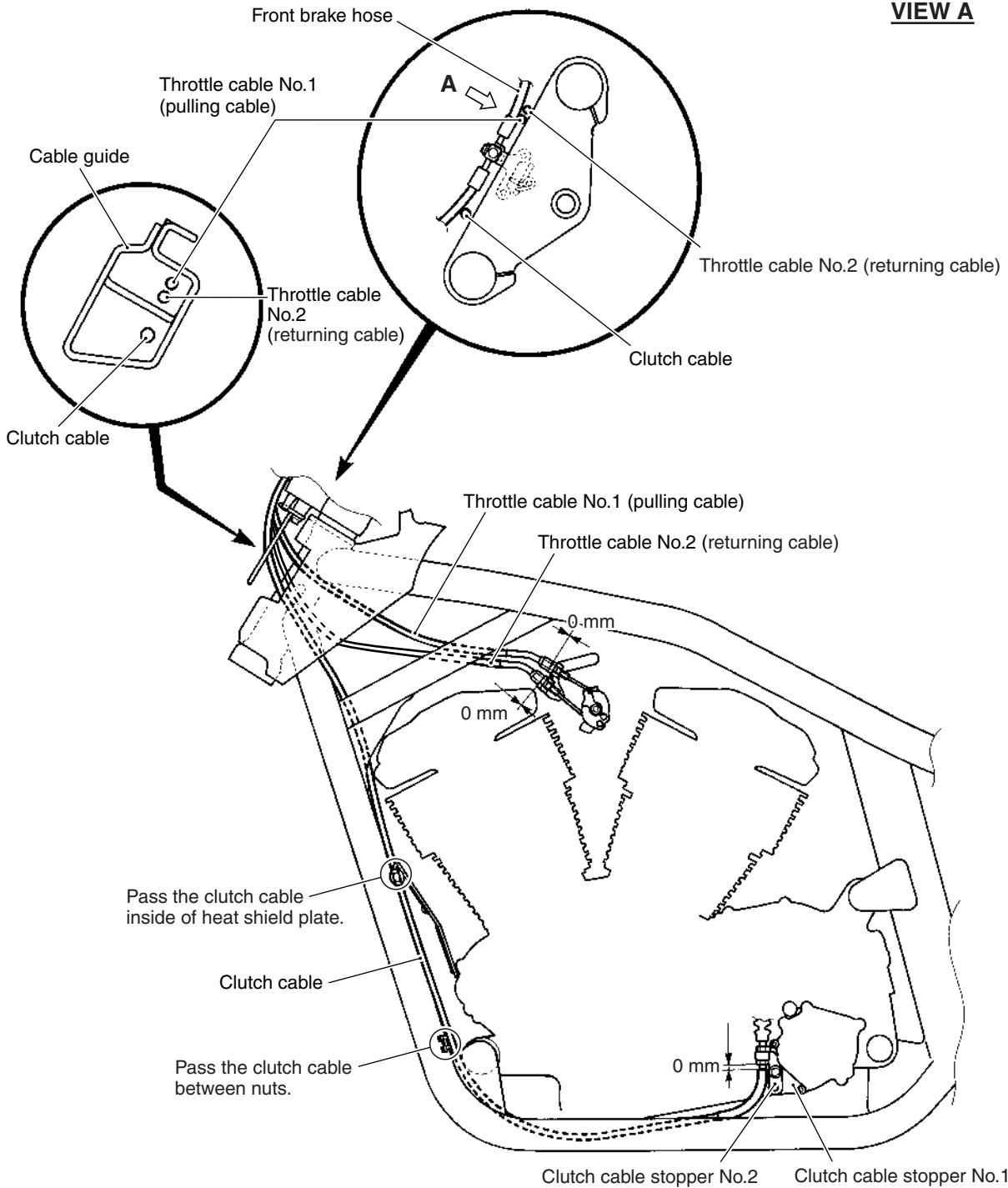
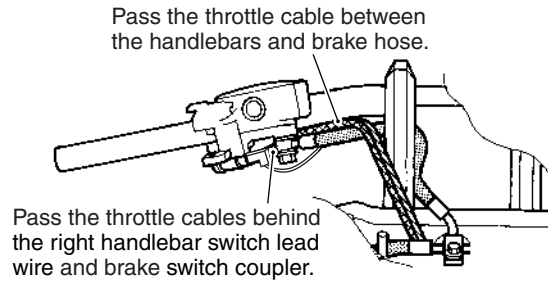

## FRONT BRAKE HOSE ROUTING

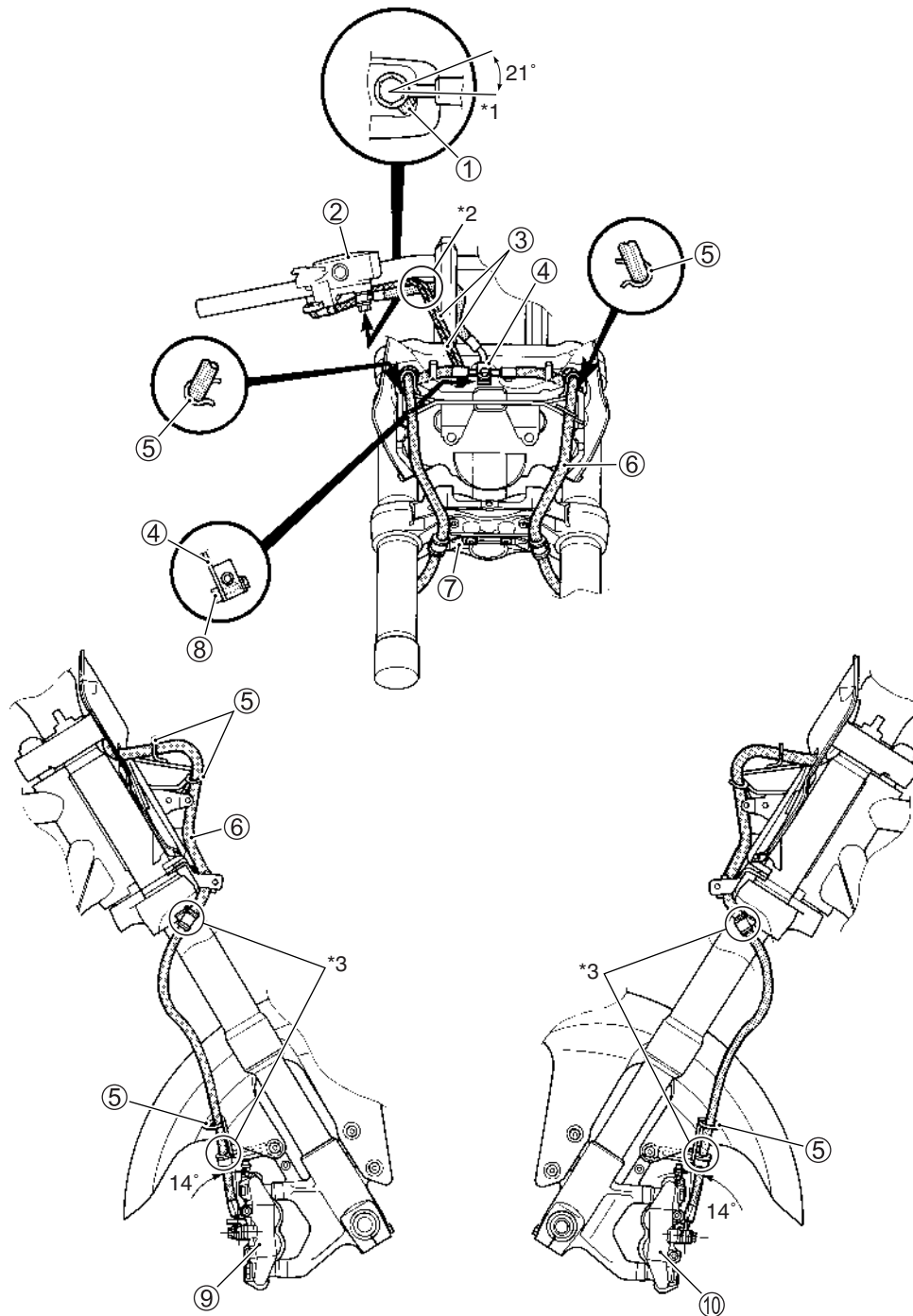

①	Stopper	⑧	Bolt
②	Brake master cylinder	⑨	Brake caliper (R)
③	Throttle cable	⑩	Brake caliper (L)
④	Cable guide	*1	Tighten the brake hose union bolt to the specified torque after touching the brake hose union to the stopper.
⑤	Hose guide	*2	Pass through the brake hose under the throttle cable.
⑥	Brake hose	*3	Fix the brake hose to the clamp.
⑦	Clamp		



## REAR BRAKE HOSE ROUTING

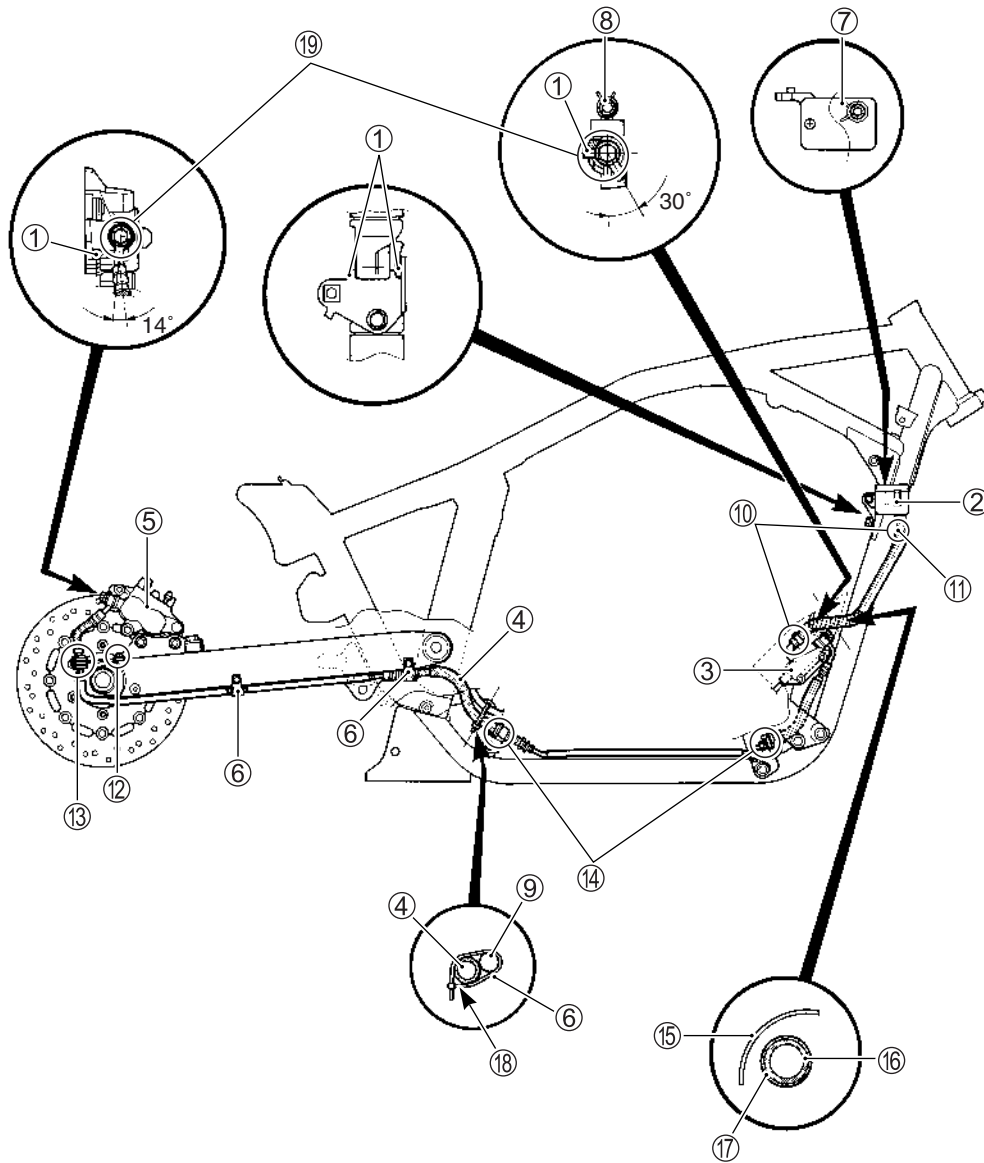

① Stopper	⑪ Face the white paint on reservoir hose to forward.
② Reservoir	⑫ Tighten the hose guide bolt after positioning the stopper of hose guide to the swingarm.
③ Brake cylinder	⑬ Fix the grommet of brake hose to the hose guide.
④ Brake hose	⑭ Fix the brake hose to the clamp.
⑤ Brake caliper	⑮ Master cylinder cover
⑥ Clamp	⑯ Reservoir hose
⑦ Face the tip of clamp to backward.	⑰ Pass the reservoir hose inside of the master cylinder cover.
⑧ Face the tip of clamp to upper.	⑱ Do not contact the hose and muffler.
⑨ Starter motor lead wire	⑲ Tighten the brake hose union bolt to the specified torque after touching the brake hose union to the stopper.
⑩ Insert the reservoir hose fully to the reservoir and brake master cylinder.	

# THROTTLE BODY HOSE ROUTING

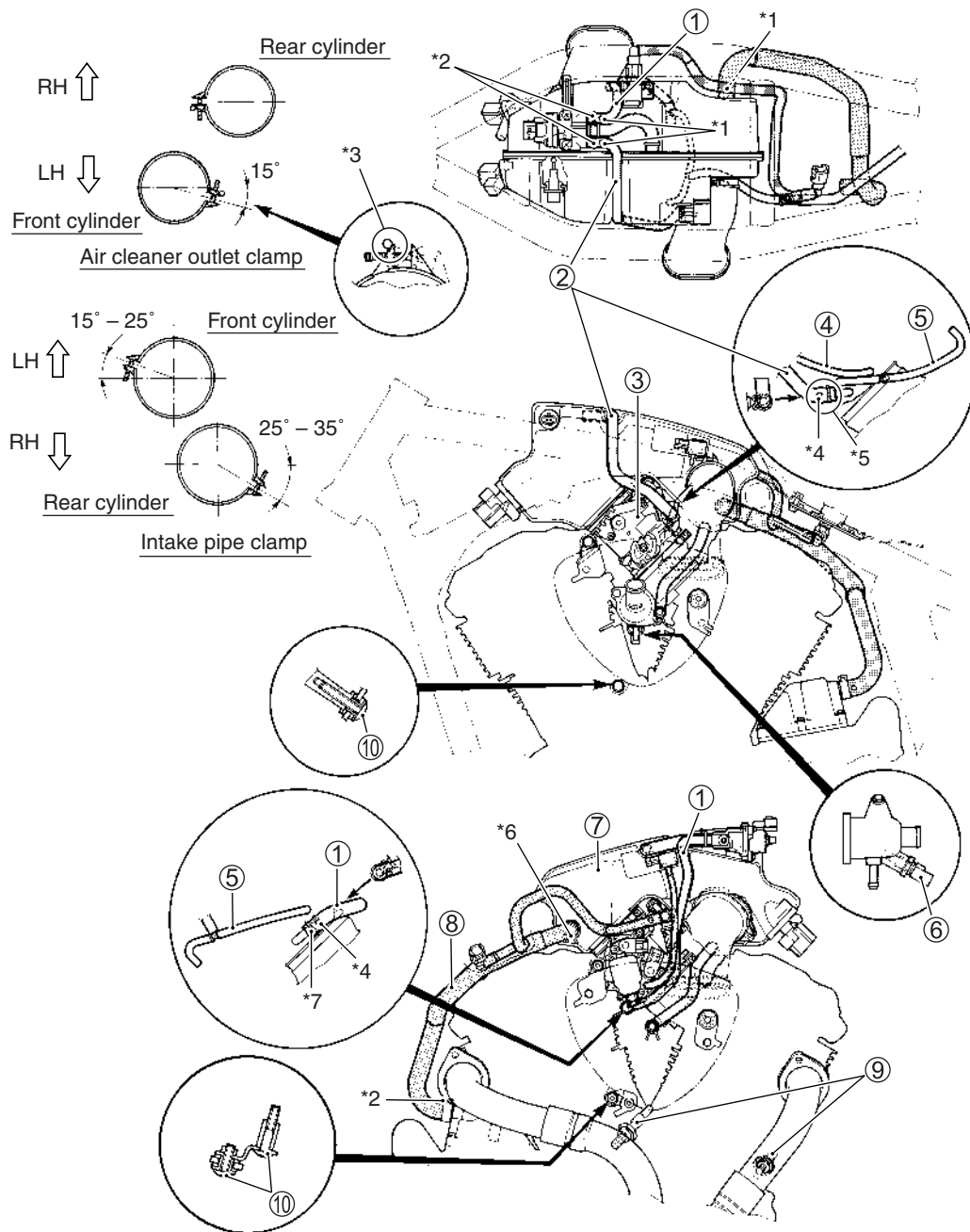

①	ISC valve hose (R)	⑩	Bolt
②	ISC valve hose (L)	*1	Yellow mark
③	Throttle body	*2	Face the tip of clip to upper.
④	Boost hose	*3	Do not touch the end of screw to the stopper when tightening it.
⑤	Purge hose (For E-33)	*4	White mark
⑥	ECT sensor	*5	Align the white mark with the bulge of nipple.
⑦	Air cleaner	*6	Face the tip of clip to lower.
⑧	Breather hose	*7	Face the tip of clip to the throttle body side.
⑨	Oxygen sensor (For E-02,19,24)		

# COOLING SYSTEM HOSE ROUTING

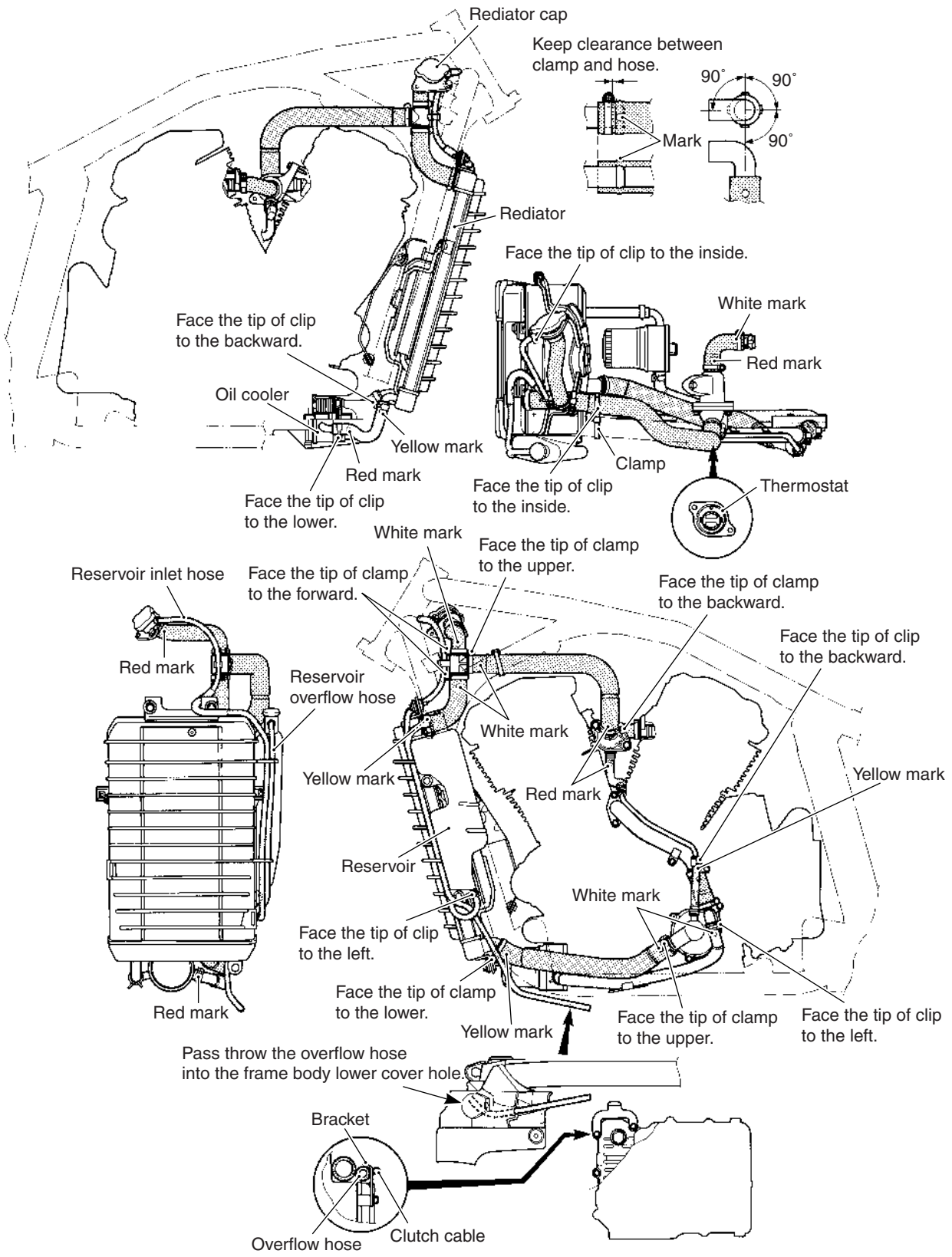

# PAIR (AIR SUPPLY) SYSTEM HOSE ROUTING (FOR E-03, 28, 33)

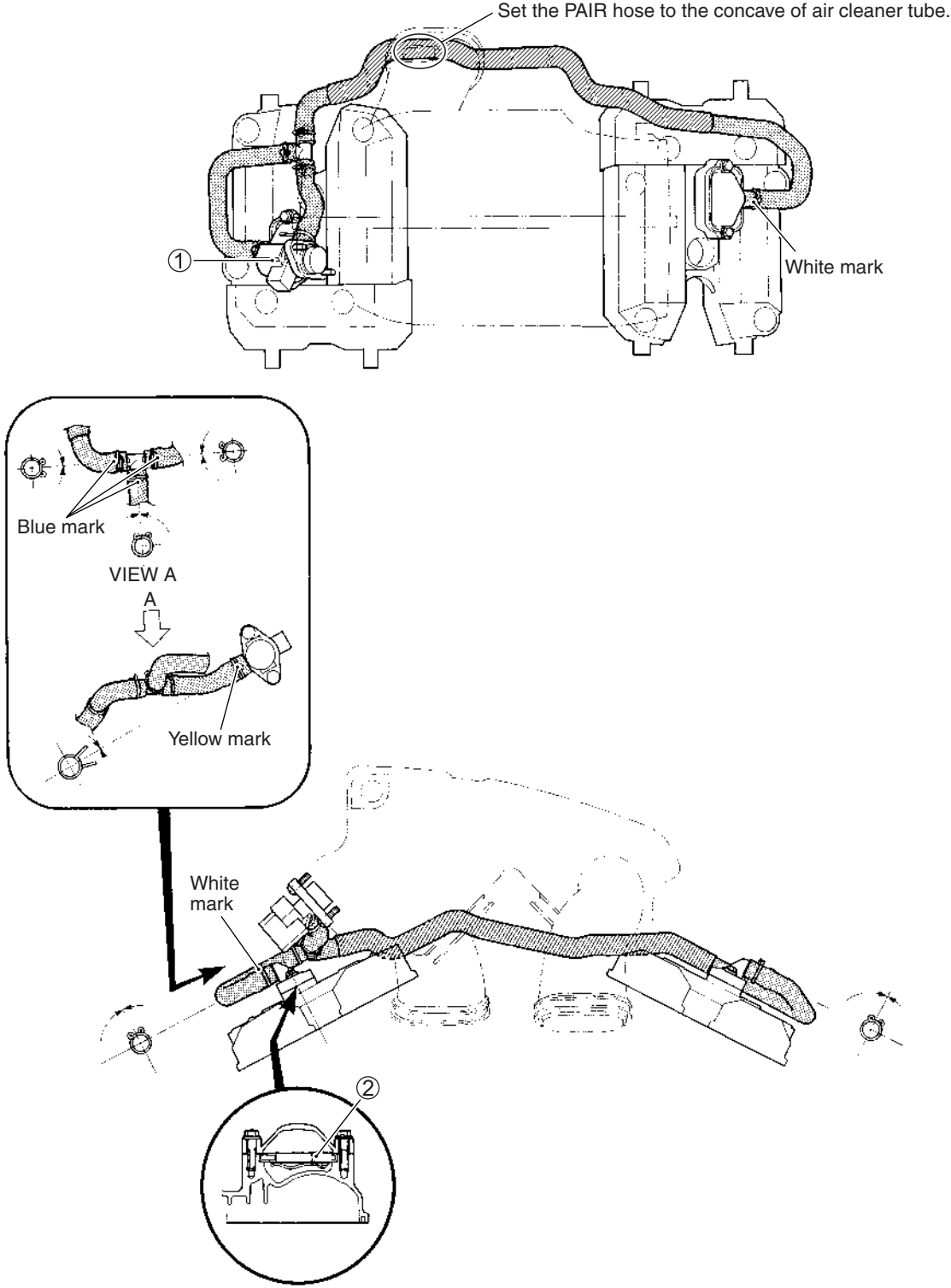

① PAIR control solenoid valve	② PAIR reed valve
-------------------------------	-------------------

## PAIR (AIR SUPPLY) SYSTEM HOSE ROUTING (FOR THE OTHERS)

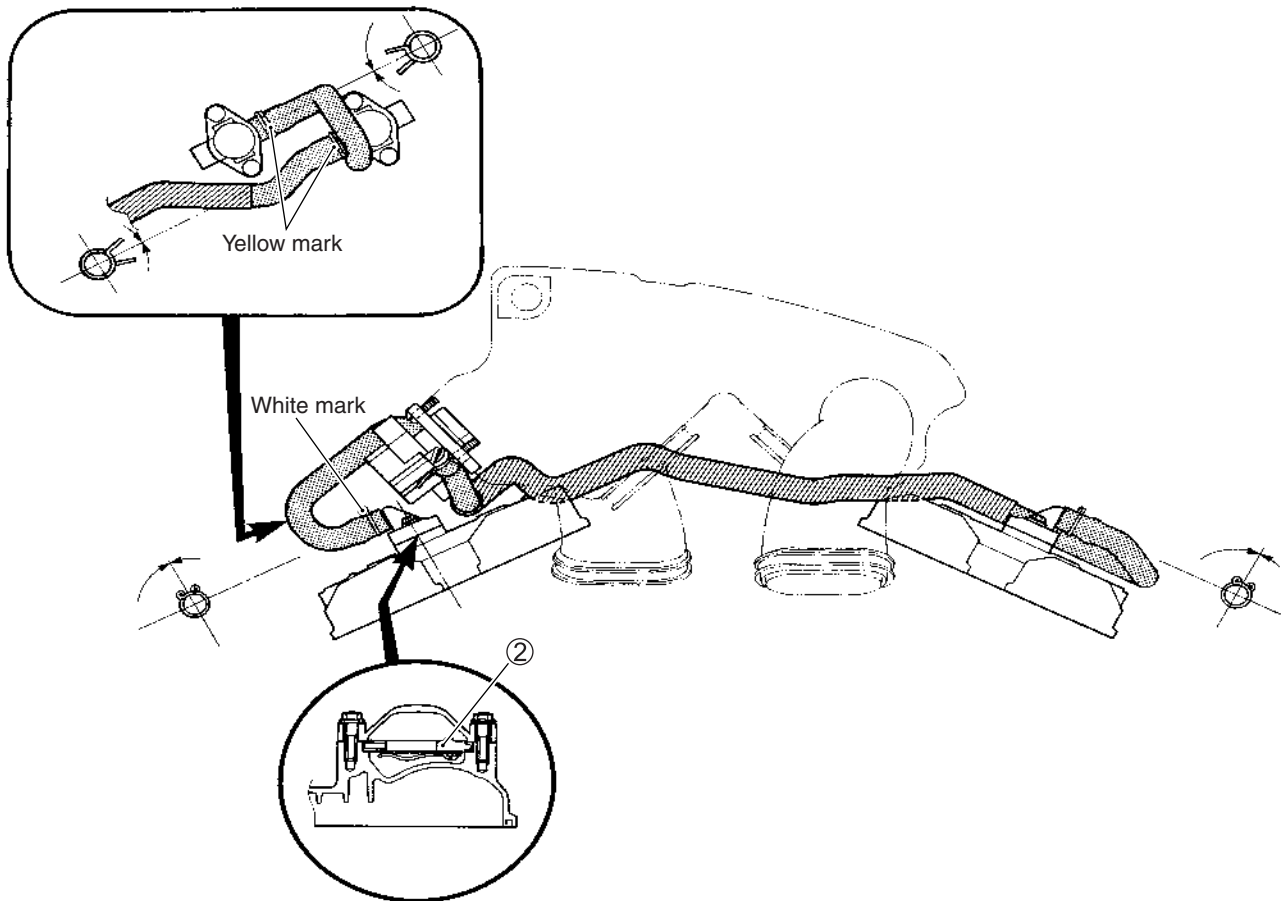
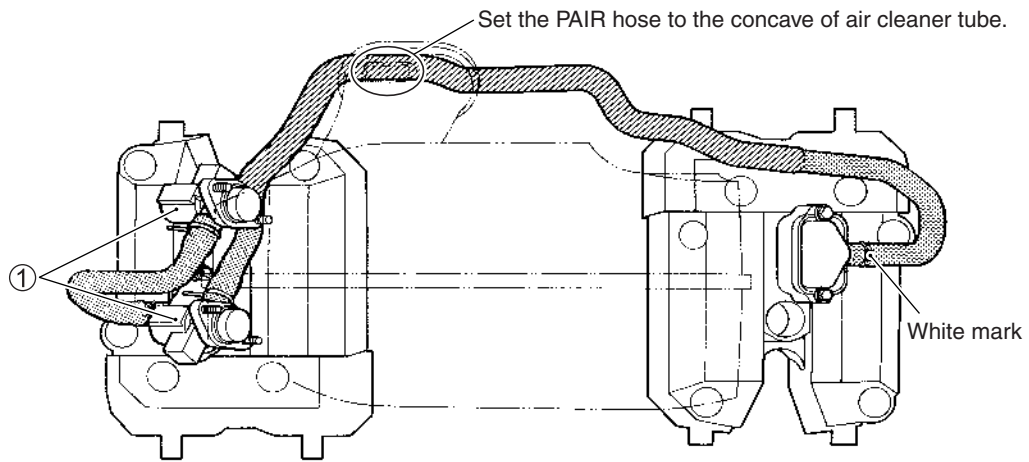

① PAIR control solenoid valve	② PAIR reed valve
-------------------------------	-------------------

## FUEL TANK INSTALLATION

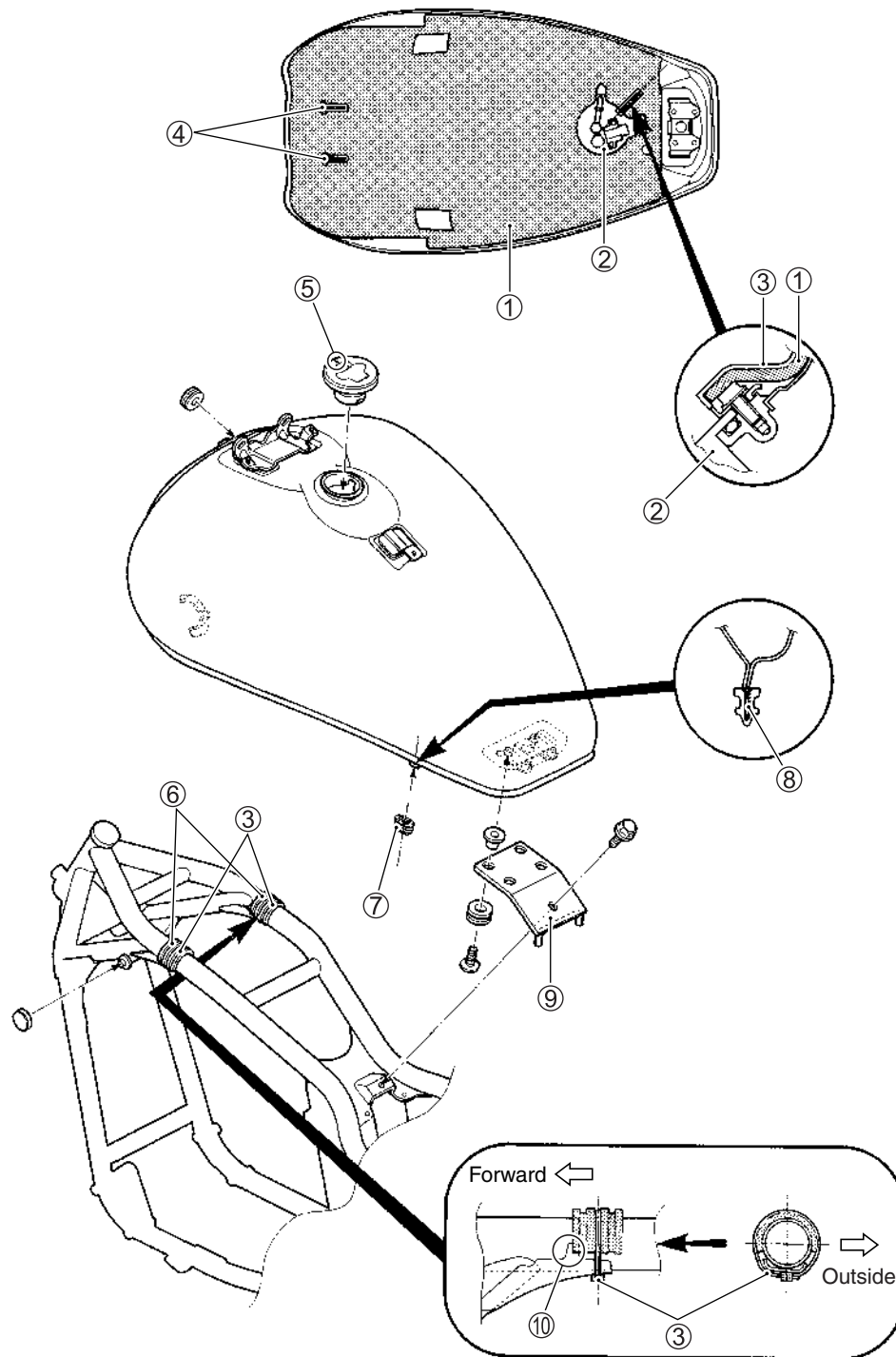

①	Heat shield	⑥	Fuel tank cushion
②	Fuel pump	⑦	Rear fender cover cushion
③	Clamp	⑧	Apply instant adhesive to the shaded portion.
④	Face the tip of clamp to the backward.	⑨	Fuel tank rear bracket
⑤	Face the arrow mark to the forward, when installing the fuel tank cap.	⑩	Attach the front of fuel tank cushion to the reinforcement of frame.

## FRAME HEAD COVER AND RADIATOR COVER INSTALLATION

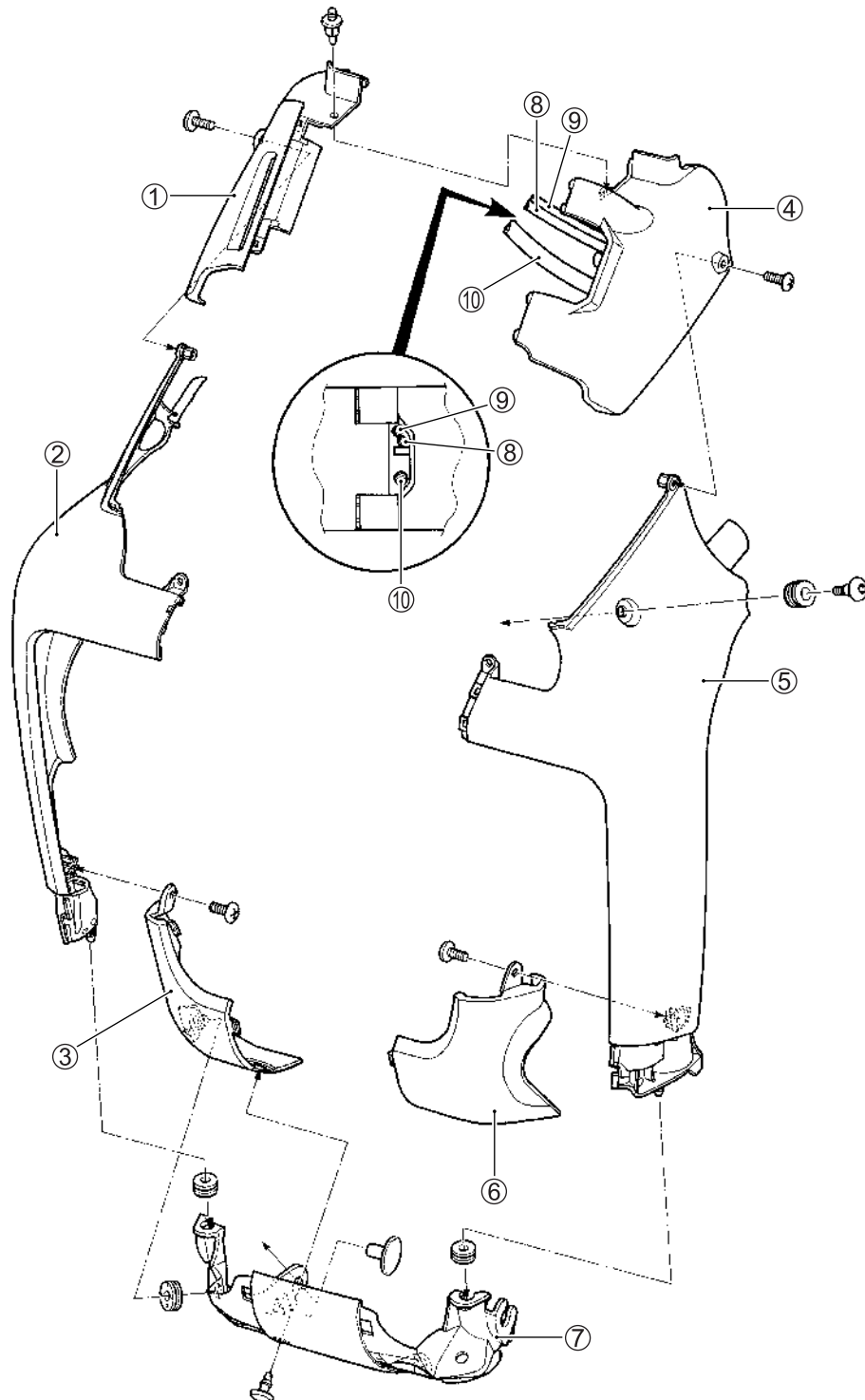

①	Frame head cover (R)	⑥	Radiator lower cover (L)
②	Radiator cover (R)	⑦	Radiator bottom cover
③	Radiator lower cover (R)	⑧	Throttle cable No.1 (pulling cable)
④	Frame head cover (L)	⑨	Throttle cable No.2 (returning cable)
⑤	Radiator cover (L)	⑩	Clutch cable



### FRAME HEAD COVER CUSHION INSTALLATION

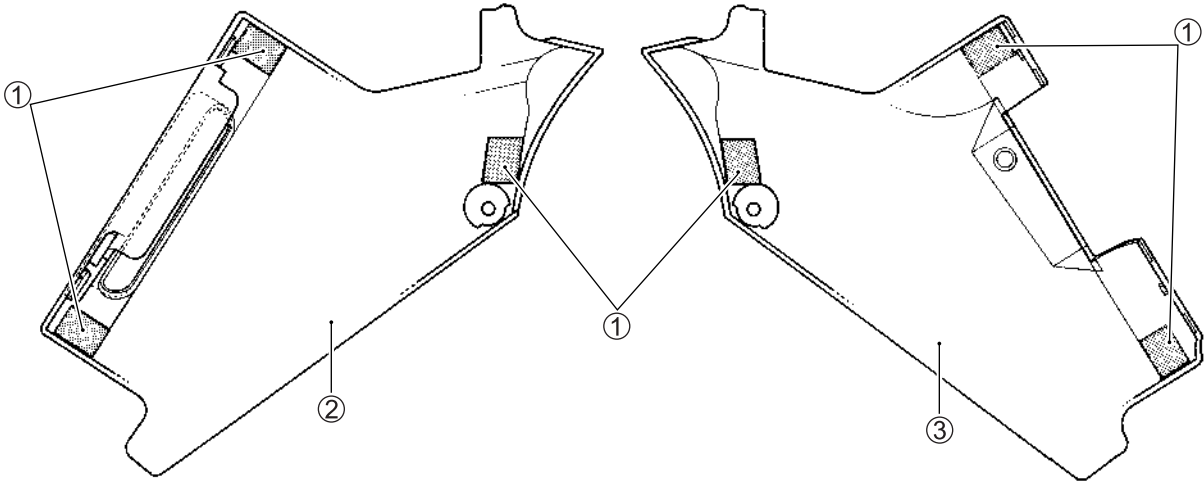

① Cushion	③ Frame head cover (L)
② Frame head cover (R)	

### RADIATOR UPPER COVER CUSHION INSTALLATION

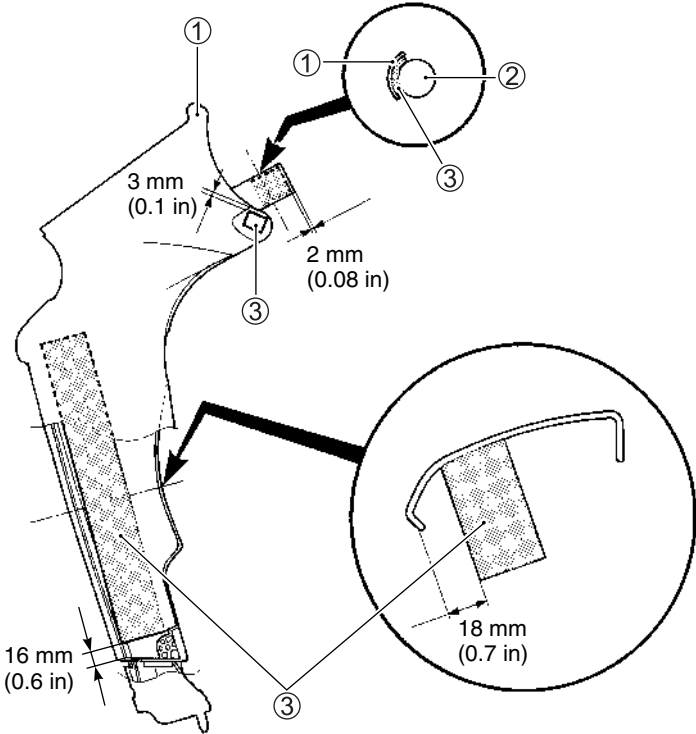

① Radiator upper cover	③ Cushion
② Frame	

## LEFT FRAME COVERS INSTALLATION

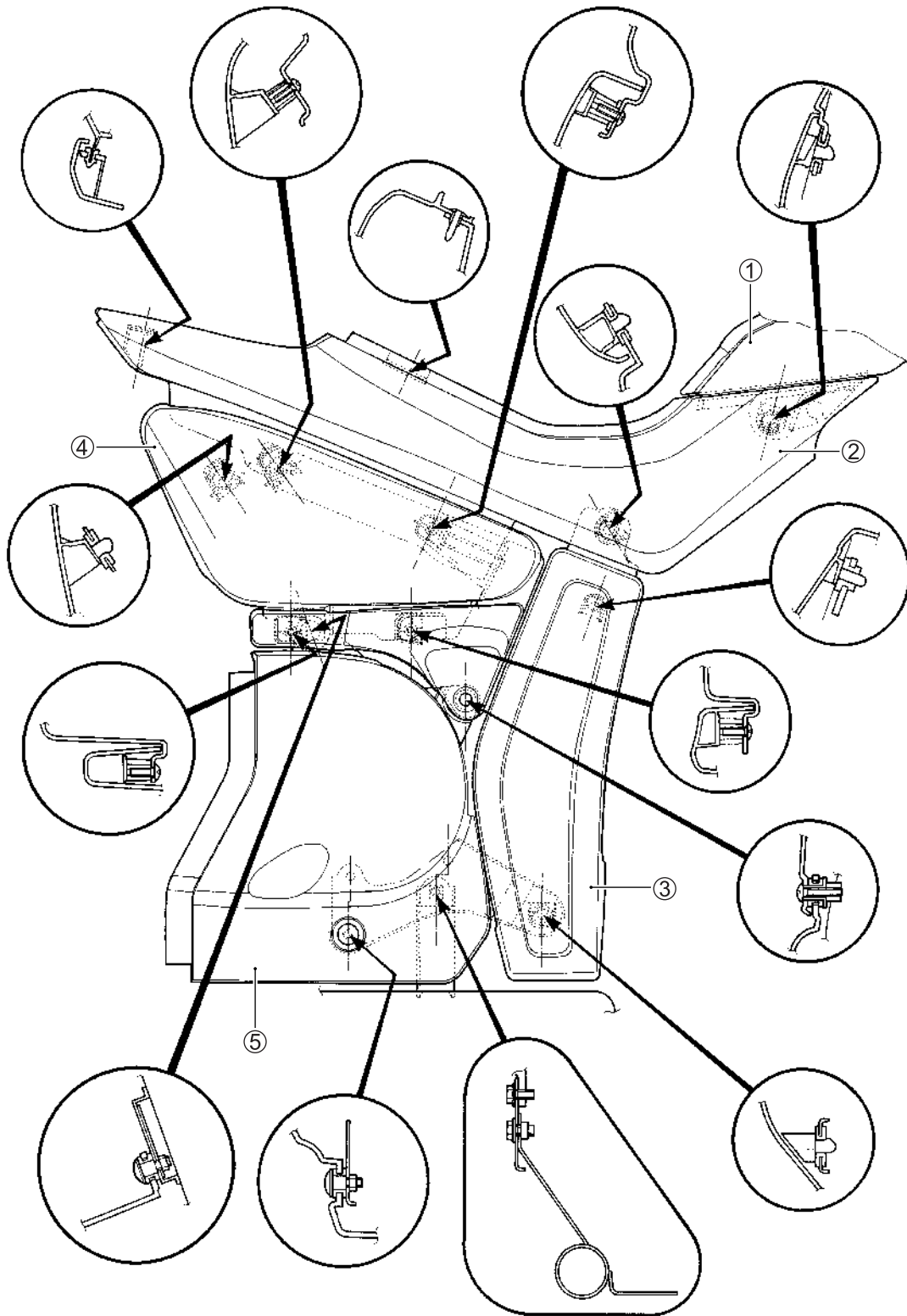

①	Rear fender	④	Side cover
②	Rear fender cover	⑤	Lower side cover
③	Rear side cover		

# RIGHT FRAME COVERS INSTALLATION

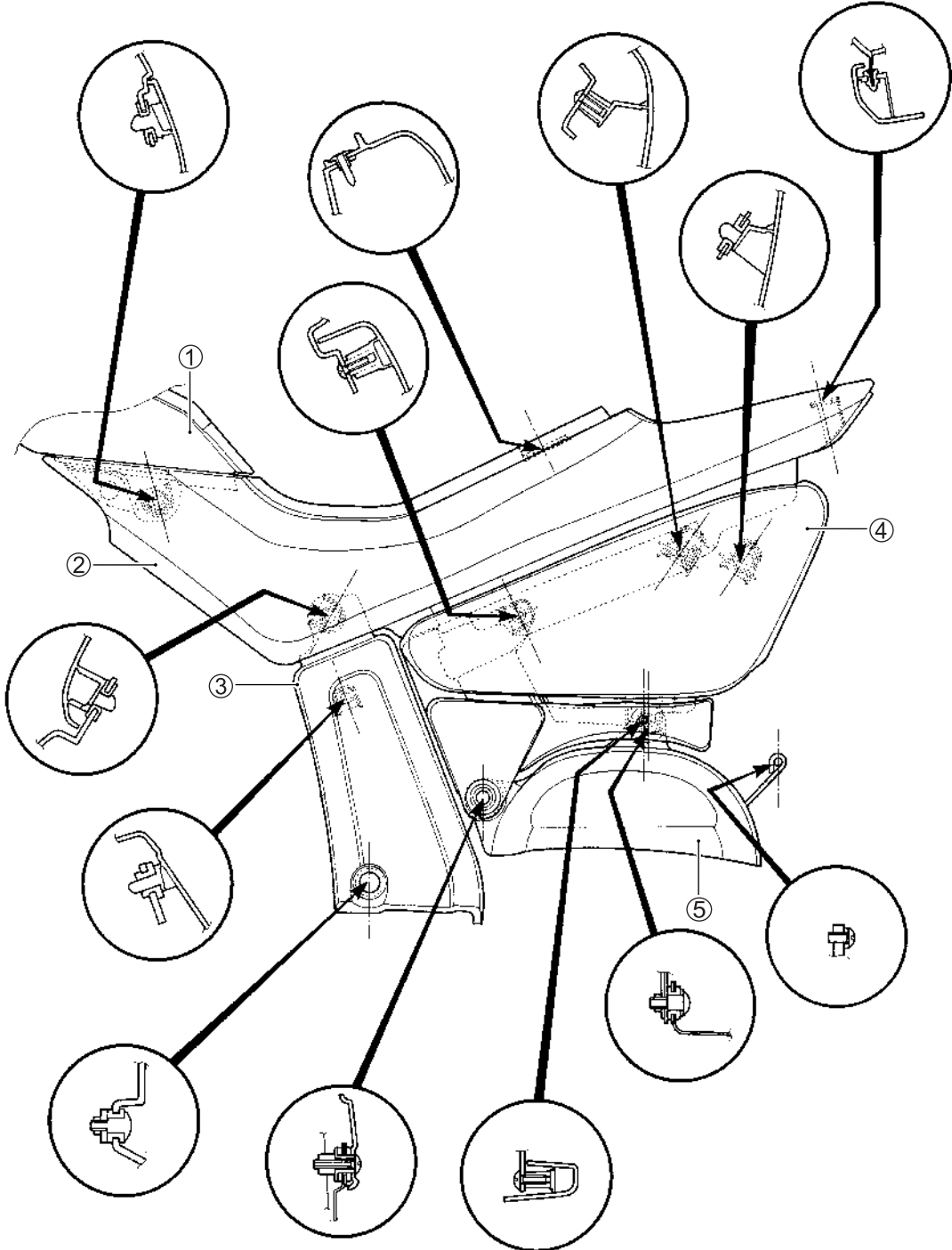

①	Rear fender	④	Side cover
②	Rear fender cover	⑤	Lower cover
③	Rear side cover		

## HEADLIGHT COVER INSTALLATION

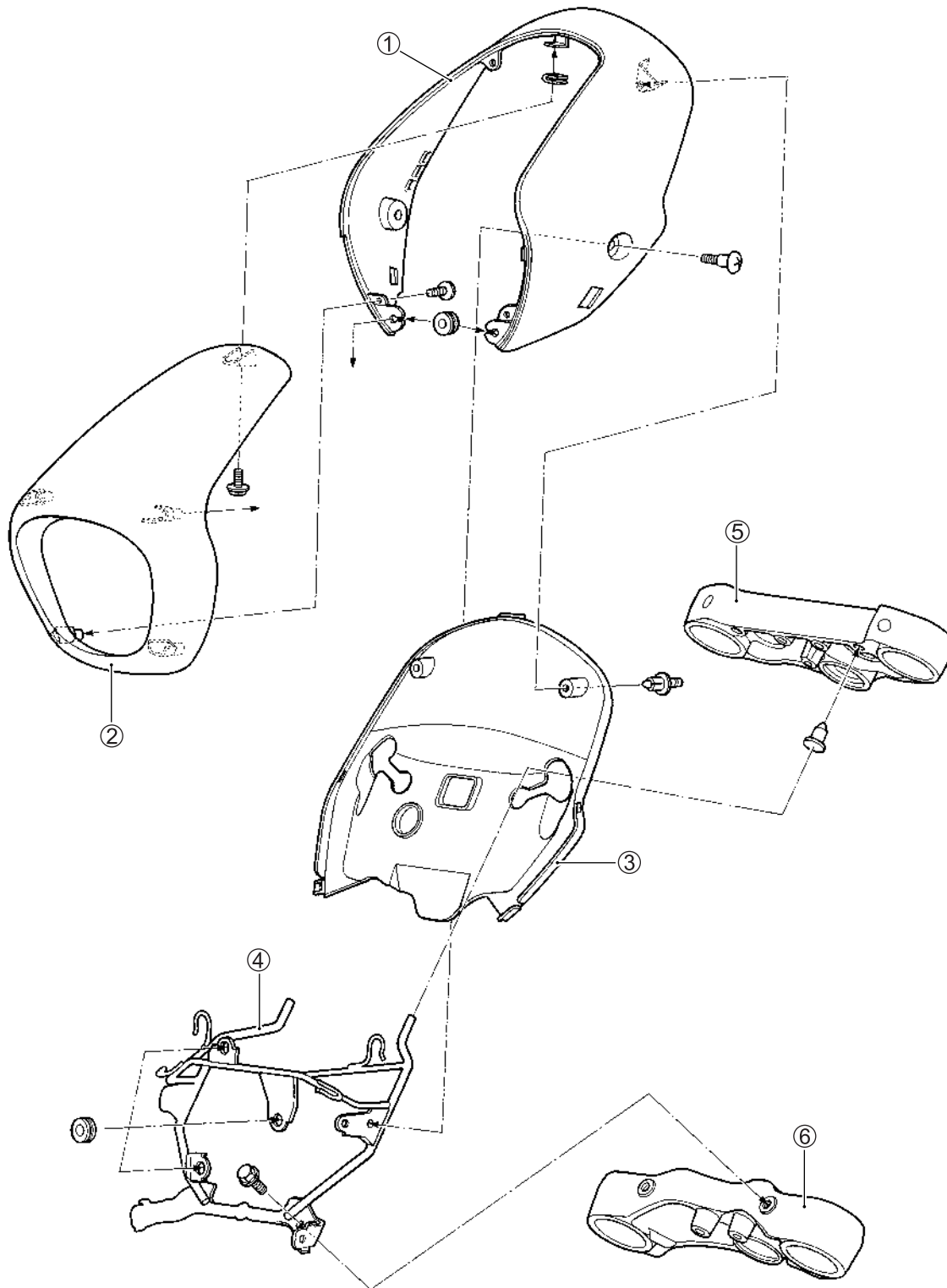

①	Headlight lower cover	④	Headlight cover brace
②	Headlight cover	⑤	Steering stem upper bracket
③	Headlight back cover	⑥	Steering stem lower bracket

### IGNITION COIL INSTALLATION

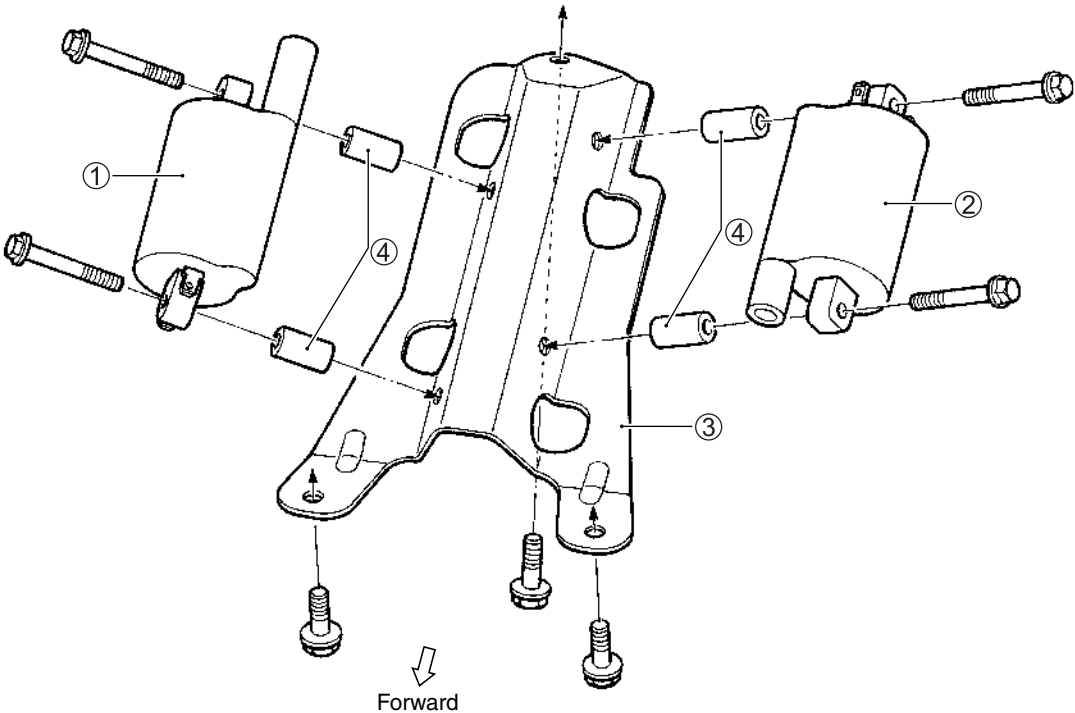

① Ignition coil #1	③ Ignition coil bracket
② Ignition coil #2	④ Spacer

### SIDE-STAND INSTALLATION

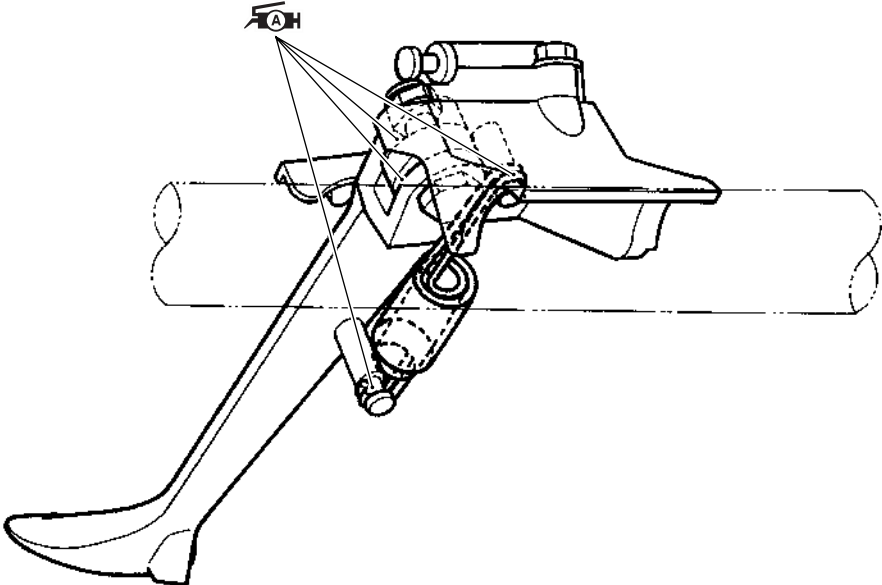

## REAR TURN SIGNAL LIGHT, LICENSE LIGHT WIRE ROUTING

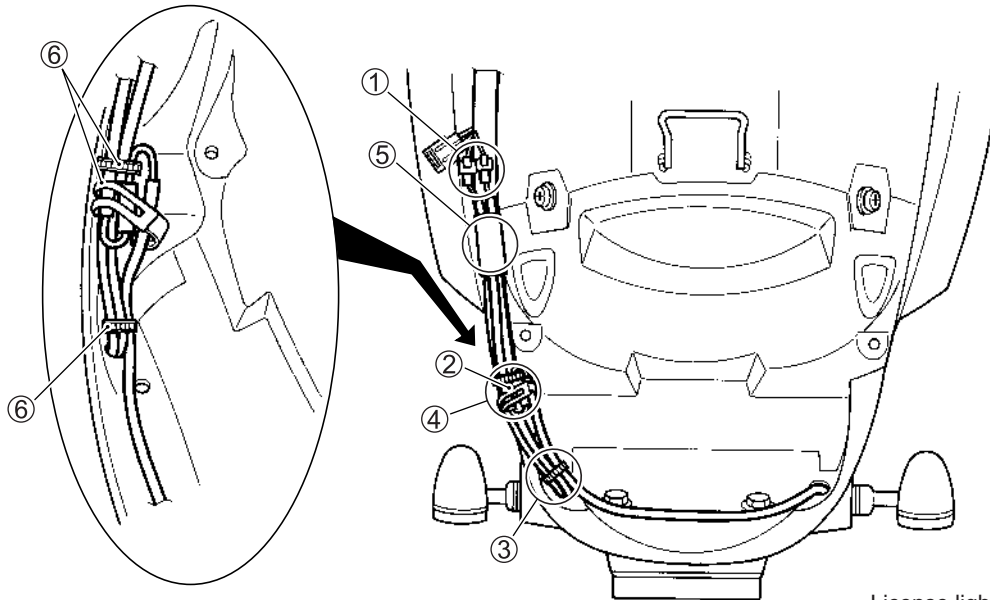

License light and right and left rear turn signal lead wires installation order.

① ⇨ ② ⇨ ③ ⇨ ④ ⇨ ⑤

①	Connect the license light and left rear turn signal light to the wiring harness.	④	Fix the right and left rear turn signal light lead wires and license light lead wire with clamp. Fit the lead wires with iron clamp.
②	Connect the right rear turn signal light lead wire to the wiring harness.	⑤	Fix the license light lead wire and left rear turn signal light lead wire with cushion.
③	Fix the right and left rear turn signal light lead wires and license light lead wire with clamp.	⑥	Clamp

## SEAT LOCK CABLE ROUTING

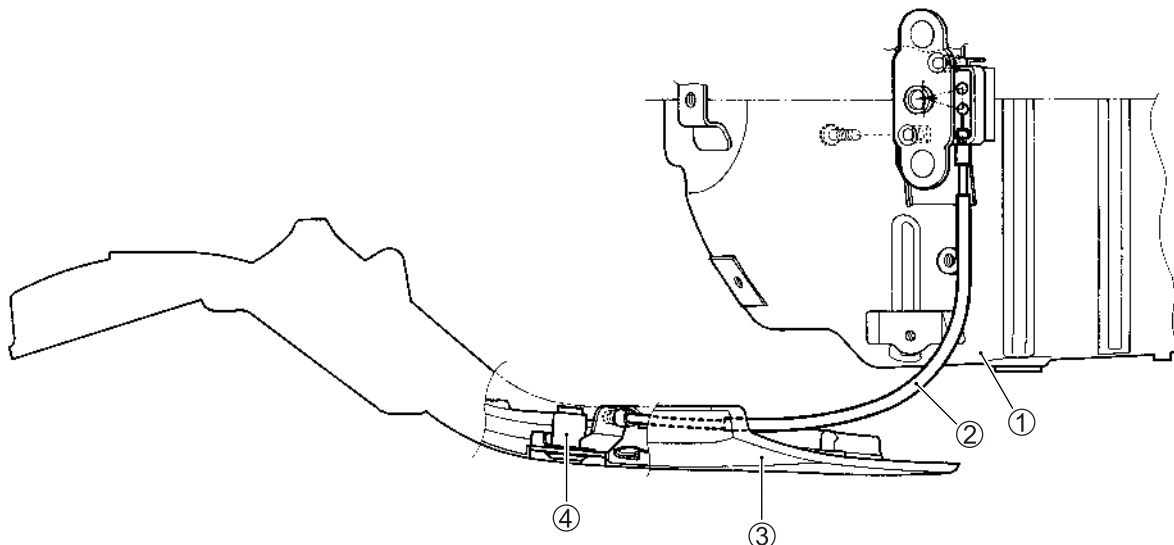

①	Rear fender brace	③	Rear fender cover (L)
②	Seat lock cable	④	Seat lock assembly

## LICENSE LIGHT AND LICENSE PLATE INSTALLATION

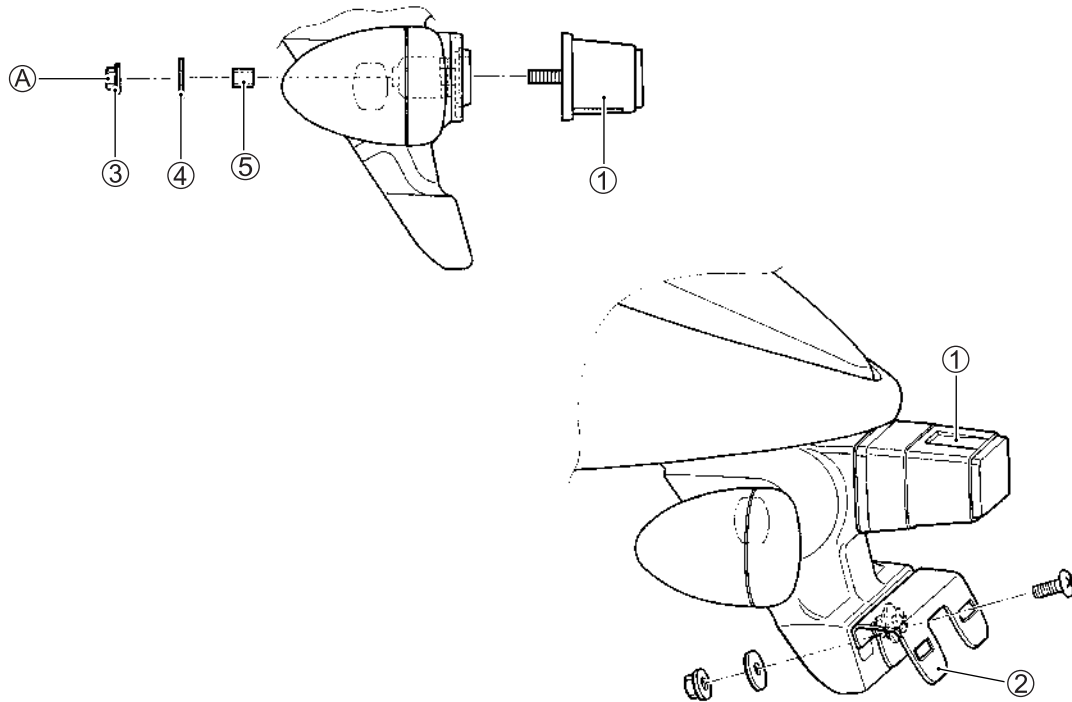

①	License light	④	Washer
②	License plate	⑤	Spacer
③	Nut	A	License light nut

ITEM	N·m	kgf·m	lb·ft
A	5	0.5	3.5

## BRAKE LIGHT/TAILLIGHT INSTALLATION

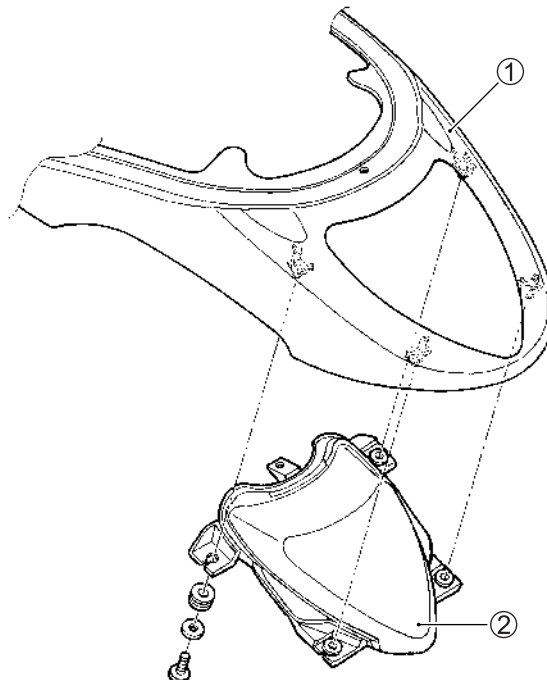

①	Rear frame cover	②	Brake light/Taillight
---	------------------	---	-----------------------



# EMISSION CONTROL INFORMATION

## CONTENTS

<b>EMISSION CONTROL SYSTEMS.....</b>	<b>12- 2</b>
<b>FUEL INJECTION SYSTEM.....</b>	<b>12- 2</b>
<b>CRANKCASE EMISSION CONTROL SYSTEM.....</b>	<b>12- 3</b>
<b>EXHAUST EMISSION CONTROL SYSTEM (PAIR SYSTEM).....</b>	<b>12- 4</b>
<b>NOISE EMISSION CONTROL SYSTEM.....</b>	<b>12- 5</b>
<b>PAIR (AIR SUPPLY) SYSTEM AND EMISSION CONTROL SYSTEM</b>	
<b>INSPECTION .....</b>	<b>12- 6</b>
<b>PAIR HOSES.....</b>	<b>12- 6</b>
<b>PAIR REED VALVE .....</b>	<b>12- 6</b>
<b>PAIR CONTROL SOLENOID VALVE.....</b>	<b>12- 6</b>
<b>PAIR (AIR SUPPLY) SYSTEM HOSE ROUTING (FOR E-03, 28, 33).....</b>	<b>12- 8</b>
<b>PAIR (AIR SUPPLY) SYSTEM HOSE ROUTING (FOR THE OTHERS) ...</b>	<b>12- 9</b>
<b>HEATED OXGEN SENSOR (HO2S) INSPECTION (FOR E-02, 19, 24)....</b>	<b>12-10</b>

## EMISSION CONTROL SYSTEMS

### FUEL INJECTION SYSTEM

VZR1800 motorcycles are equipped with a fuel injection system for emission level control. This fuel injection system is precision designed, manufactured and adjusted to comply with the applicable emission limits. With a view to reducing CO, NOX and HC, all of the fuel injection volumes are stringently controlled with the programmed injection maps in the ECM by varying engine conditions. Adjusting, interfering with, improper replacement, or resetting of any of the fuel injection components may adversely affect injection performance and cause the motorcycle to exceed the exhaust emission level limits. If unable to effect repairs, contact the distributor's representative for further technical information and assistance.

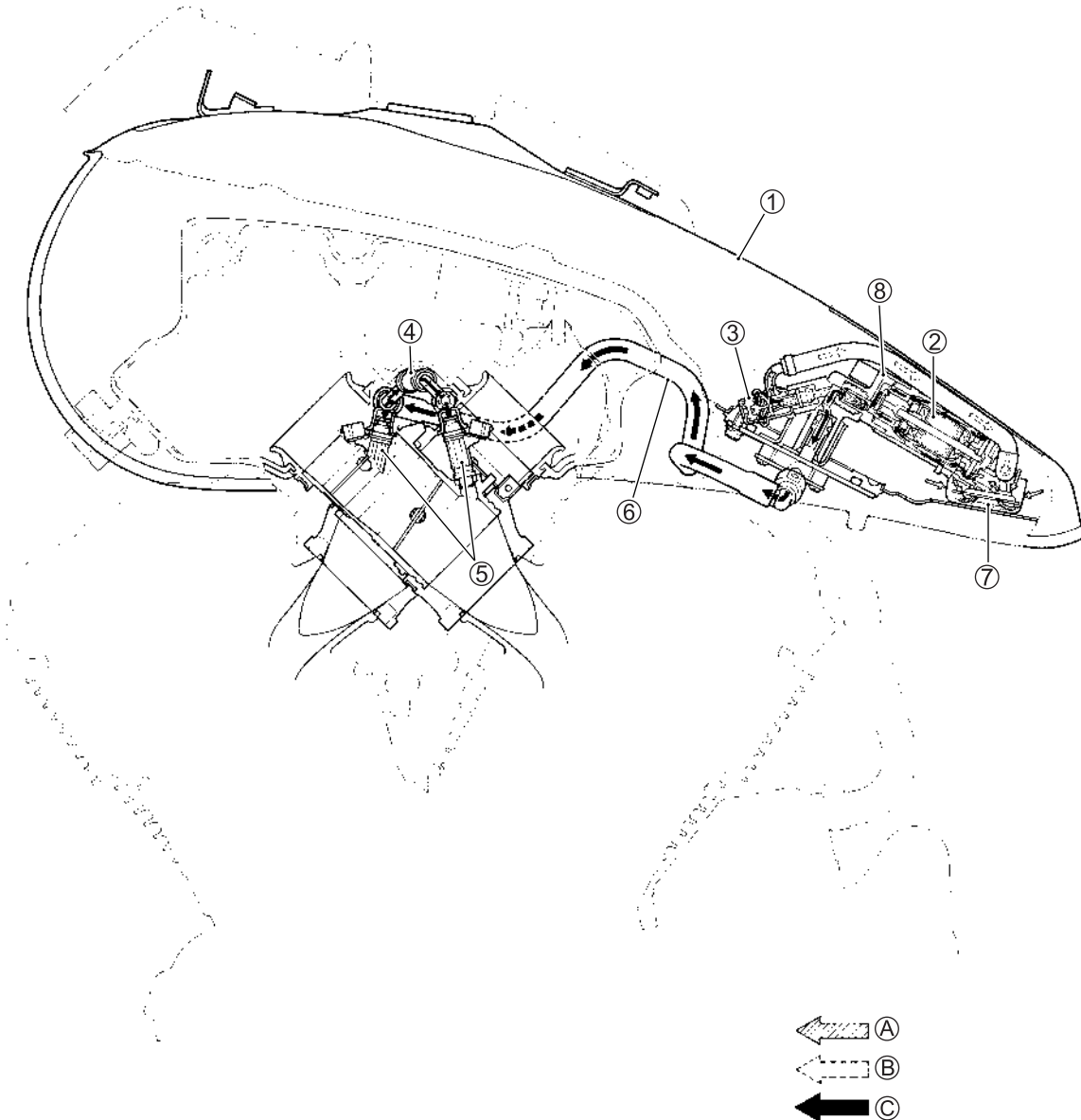

①	Fuel tank	⑦	Fuel mesh filter (For low pressure)
②	Fuel filter (For high pressure)	⑧	Fuel pump
③	Fuel pressure regulator	(A)	Before-pressurized fuel
④	Fuel delivery pipe	(B)	Relieved fuel
⑤	Fuel injector	(C)	Pressurized fuel
⑥	Fuel feed hose		

## CRANKCASE EMISSION CONTROL SYSTEM

The engine is equipped with a PCV system to prevent discharging crankcase emissions into the atmosphere. Blow-by gas in the engine is constantly drawn into the crankcase, which is returned to the combustion chamber through the PCV (breather) hose, air cleaner and throttle body.

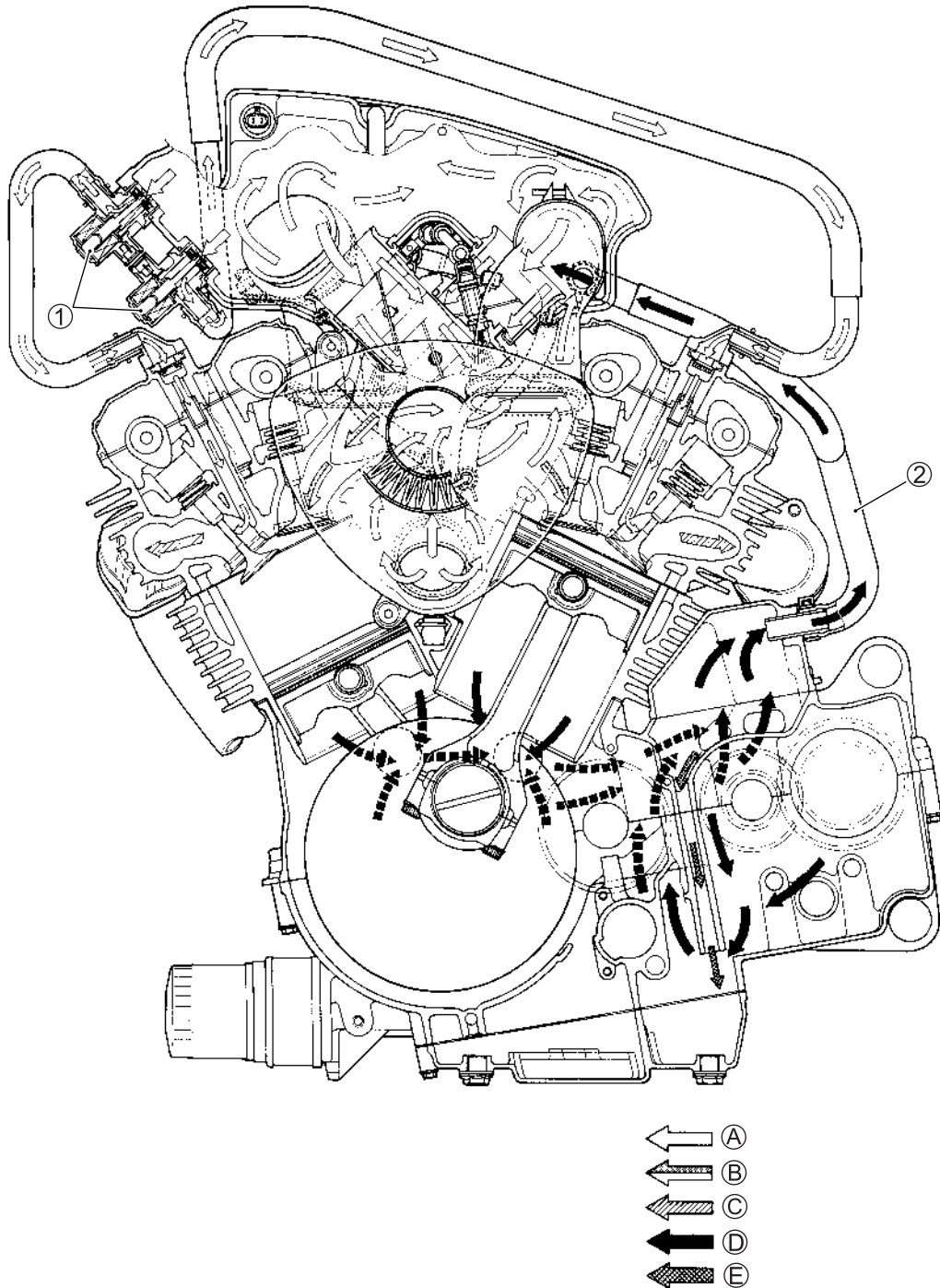

① PAIR control solenoid valve	③ EXHAUST GAS
② PCV hose	④ BLOW-BY GAS
⑤ FRESH AIR	⑤ RETURN OIL
⑥ FUEL/AIR MIXTURE	

## EXHAUST EMISSION CONTROL SYSTEM (PAIR SYSTEM)

The exhaust emission control system is composed of the PAIR system, exhaust control system and three-way catalyst system. The fresh air is drawn into the exhaust port through the PAIR control solenoid valve and PAIR reed valve. The PAIR control solenoid valve is operated by the ECM, and the fresh air flow is controlled according to the TPS, ECTS, IATS, IAPS and CKPS. The exhaust gas flow is performed by the exhaust control valve actuator which is controlled by the ECM by changing the exhaust control valve angle.

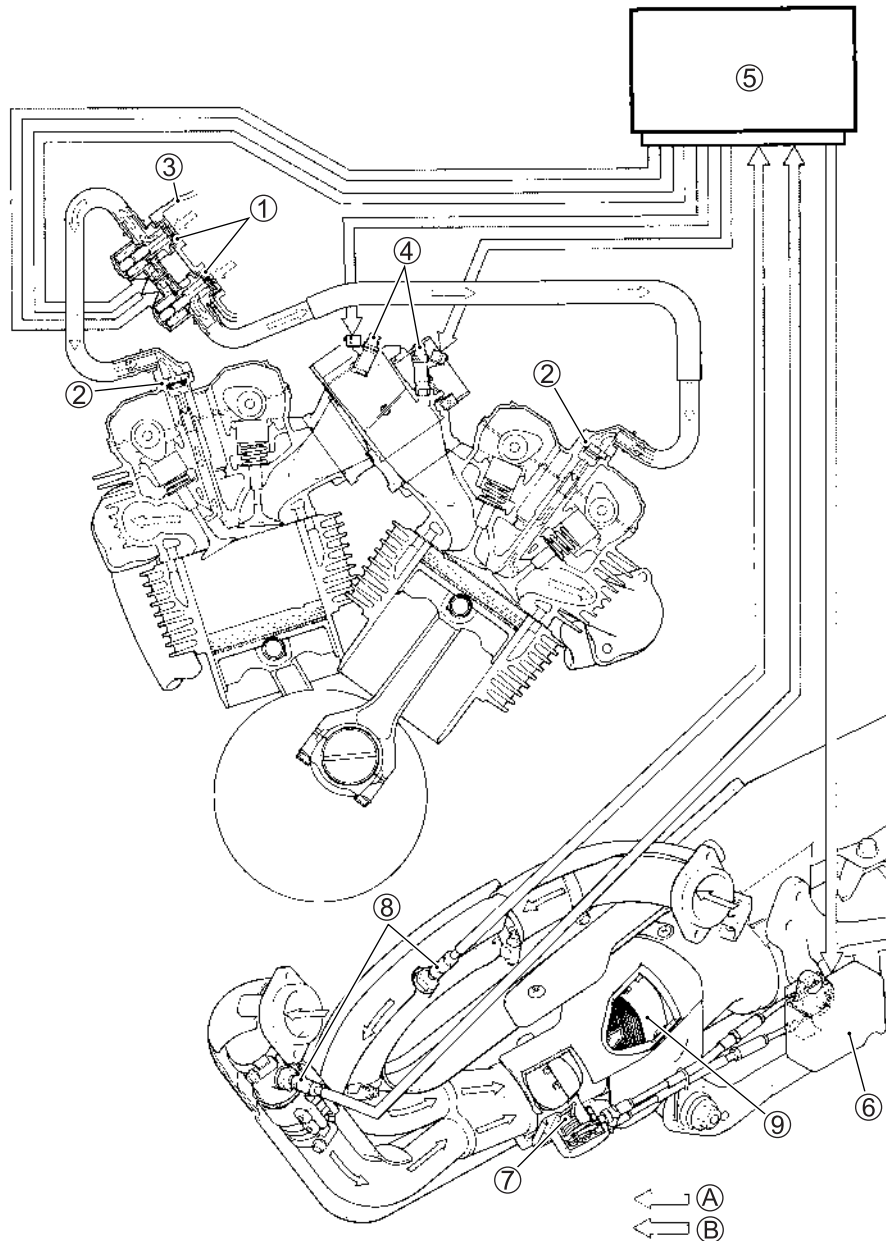

① PAIR control solenoid valve	⑦ Exhaust control valve
② PAIR reed valve	⑧ HO2 sensor (For E-02, 19, 24)
③ Air cleaner box	⑨ Three-way catalyst (For E-02, 19)
④ Fuel injector	Ⓐ FRESH AIR
⑤ ECM	Ⓑ EXHAUST GAS
⑥ Exhaust control valve actuator	

## **NOISE EMISSION CONTROL SYSTEM**

TAMPERING WITH THE NOISE CONTROL SYSTEM PROHIBITED: Local law prohibits the following acts or the causing thereof:

1. The removal or rendering inoperative by any person, other than for purposes of maintenance, repair or replacement, of any device or element of design incorporated into any new vehicle for the purpose of noise control prior to its sale or delivery to the ultimate purchaser or while it is in use, or
2. The use of the vehicle after such device or element of design has been removed or rendered inoperative by any person.

### **AMONG THOSE ACTS PRESUMED TO CONSTITUTE TAMPERING ARE THE ACTS LISTED BELOW:**

- Removing or puncturing the muffler, baffles, header pipes, screen type spark arrester (if equipped) or any other component which conducts exhaust gases.
- Removing or puncturing the air cleaner case, air cleaner cover, baffles or any other component which conducts intake air.
- Replacing the exhaust system or muffler with a system or muffler not marked with the same model specific code as the code listed on the Motorcycle Noise Emission Control Information label.

## PAIR (AIR SUPPLY) SYSTEM AND EMISSION CONTROL SYSTEM INSPECTION

### PAIR HOSES

- Remove the frame head covers. (☞9-6)
- Inspect the PAIR hoses for wear or damage.
- Inspect the PAIR hoses for secure connection.

### PAIR REED VALVE

- Remove the fuel tank. (☞6-3)
- Remove the PAIR reed valve cover. (☞3-29)
- Inspect the reed valve for the carbon deposit.
- If the carbon deposit is found in the reed valve, replace the PAIR reed valve with a new one.



### PAIR CONTROL SOLENOID VALVE REMOVAL

- Remove the air cleaner chamber. (☞6-13)
- Remove the PAIR control solenoid valve ①.

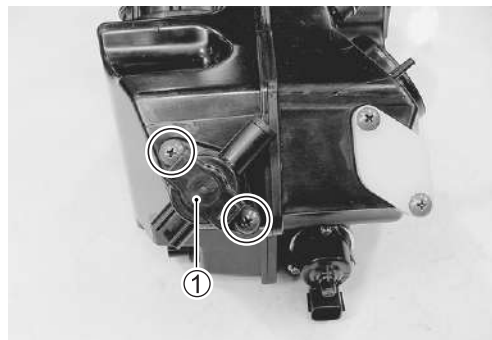

### INSPECTION

- Check that air flows through the air inlet port to the air outlet port.
- If air does not flow out, replace the PAIR control solenoid valve with a new one.

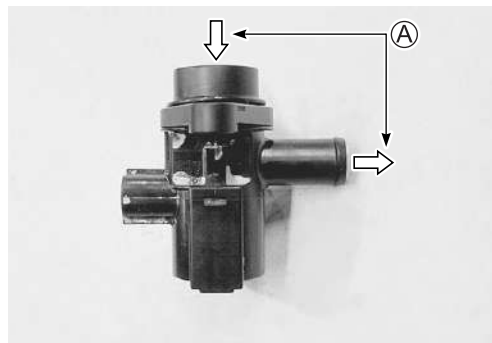

Ⓐ Air flow

- Connect the 12 V battery to the PAIR control solenoid valve terminals and check the air flow.
- If air does not flow out, the solenoid valve is in normal condition.

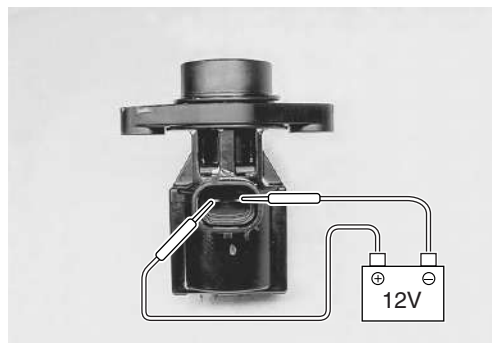

- Check the resistance between the terminals of the PAIR control solenoid valve.

**DATA** Resistance: 18 – 22  $\Omega$  at 20 – 30 °C (68 – 86 °F)

**TOOL** 09900-25008: Multi-circuit tester set

**Tester knob indication: Resistance ( $\Omega$ )**

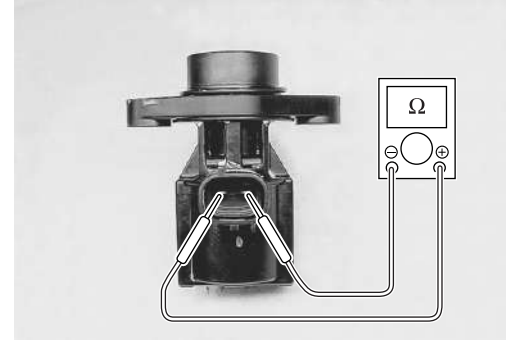

## INSTALLATION

If the resistance is not within the standard range, replace the PAIR control solenoid valve with a new one.

Installation is in the reverse order of removal. Pay attention to the following points:

- Install the PAIR control solenoid valve to the air cleaner chamber.
- Apply thin coat of the engine oil to the new O-rings.

### CAUTION

**Replace the O-rings with the new ones.**

- Connect the PAIR control solenoid valve lead wire coupler and PAIR hoses securely.
- PAIR system hose routing (📄 12-8 to -9)





## PAIR (AIR SUPPLY) SYSTEM HOSE ROUTING (FOR E-03, 28, 33)

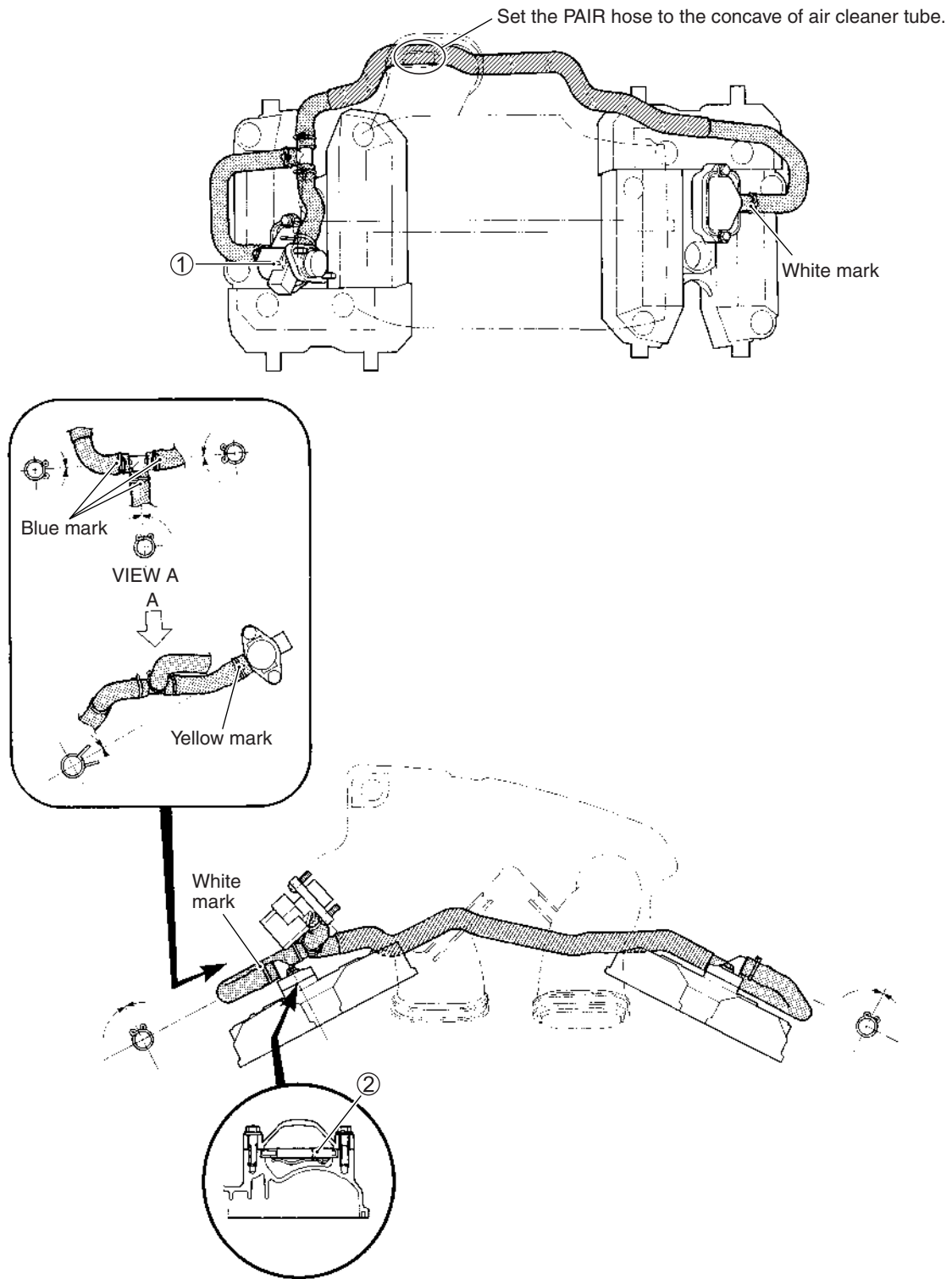

# PAIR (AIR SUPPLY) SYSTEM HOSE ROUTING (FOR THE OTHERS)

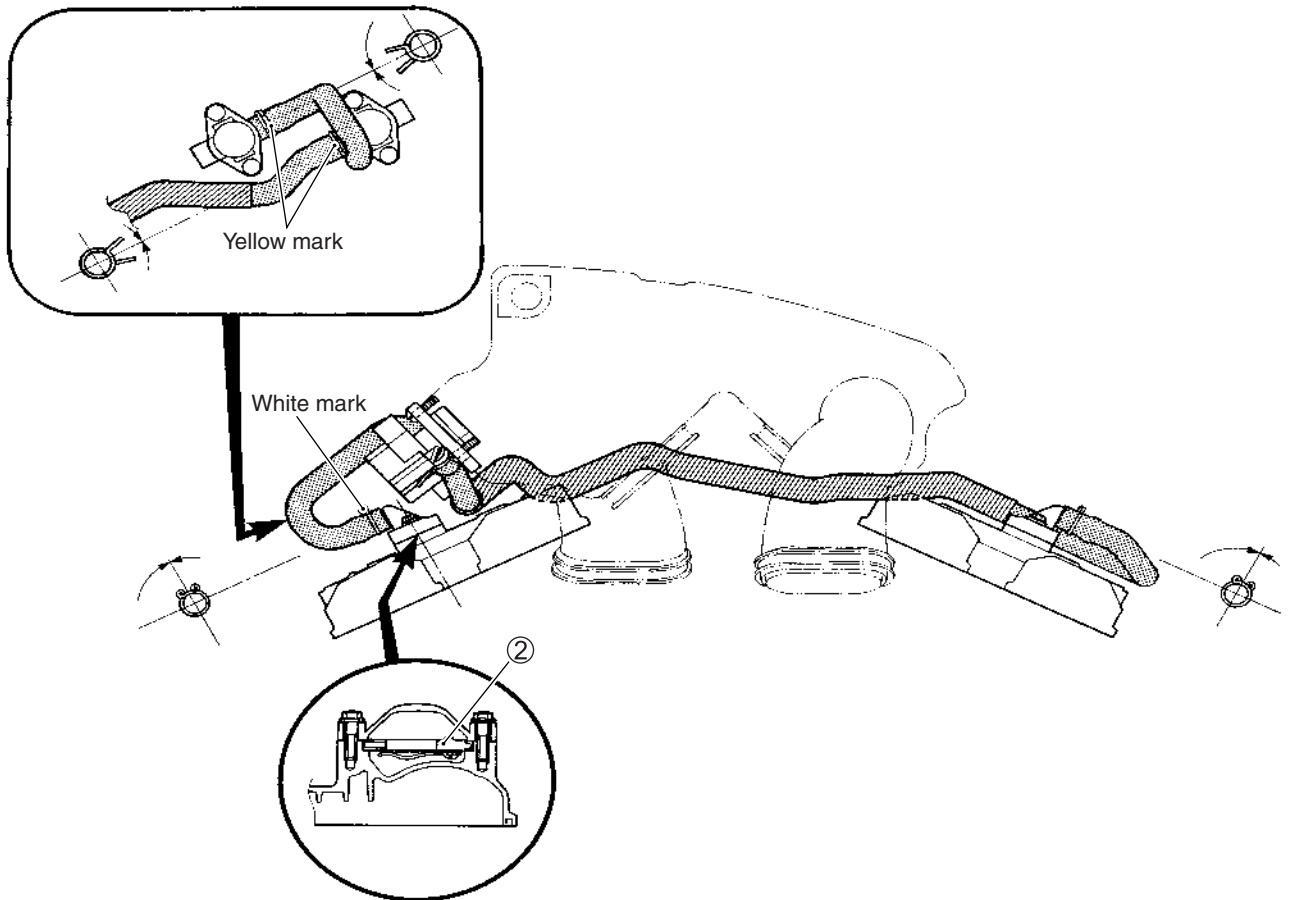
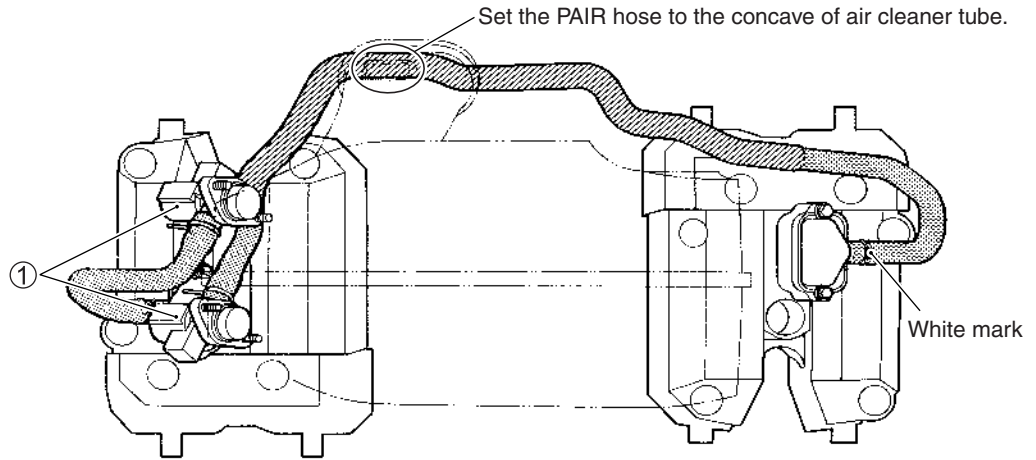

① PAIR control solenoid valve	② PAIR reed valve
-------------------------------	-------------------

## HEATED OXGEN SENSOR (HO2S) INSPECTION (FOR E-02, 19, 24)

- Disconnect the HO2 sensor lead wire coupler. (☞ 5-79)
- Inspect the HO2 sensor and its circuit referring to flow table of the malfunction code C44 or 64 (P0156/P0161 or P0130/P0135).

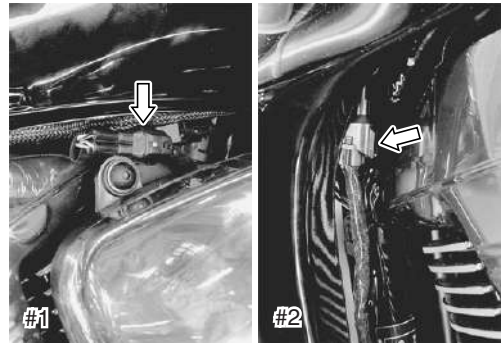

- Check the resistance between the terminals of the HO2 sensor.

**DATA** Resistance: 4.0 – 5.5  $\Omega$  at 23 °C (73.4 °F)  
(White – White)

**TOOL** 09900-25008: Multi-circuit tester set

**Tester knob indication: Resistance ( $\Omega$ )**

If the resistance is not within the standard range, replace the HO2 sensor with a new one.

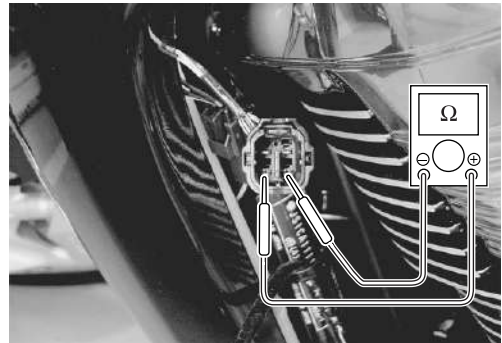

### NOTE:

- \* Temperature of the sensor affects resistance value largely.
- \* Make sure that the sensor heater is at correct temperature.

### ⚠ WARNING

**Do not remove the HO2 sensor while it is hot.**

### CAUTION

**Be careful not to expose it to excessive shock.  
Do not use an impact wrench while removing or installing the HO2 sensor unit.  
Be careful not to twist or damage the sensor lead wire.**

- Installation is in the reverse order of removal.

### CAUTION

**Do not apply oil or other materials to the sensor air hole.**

- Tighten the sensor unit to the specified torque.

**HO2 sensor: 48 N·m (4.8 kgf-m, 34.5 lb-ft)**

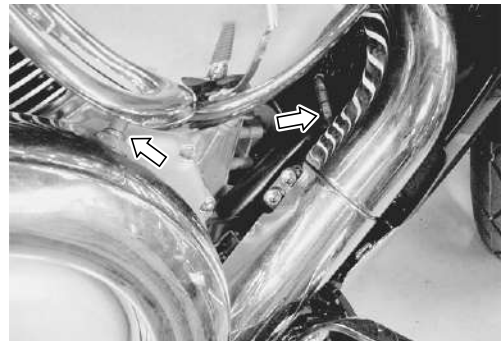

# WIRING DIAGRAM

## E-02, 19, 24

Wiring diagrams wire color, refer to section "WIRE COLOR".

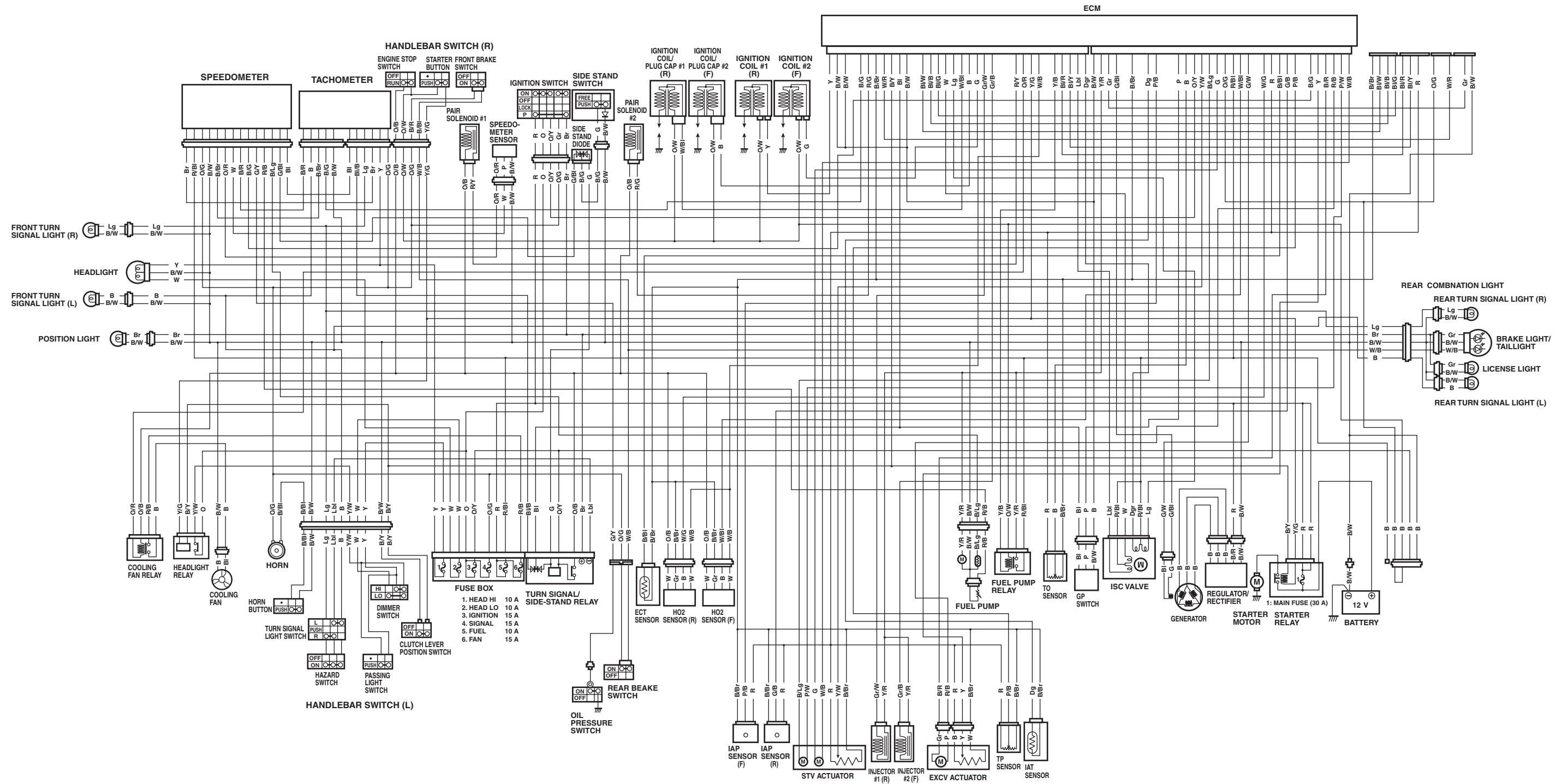

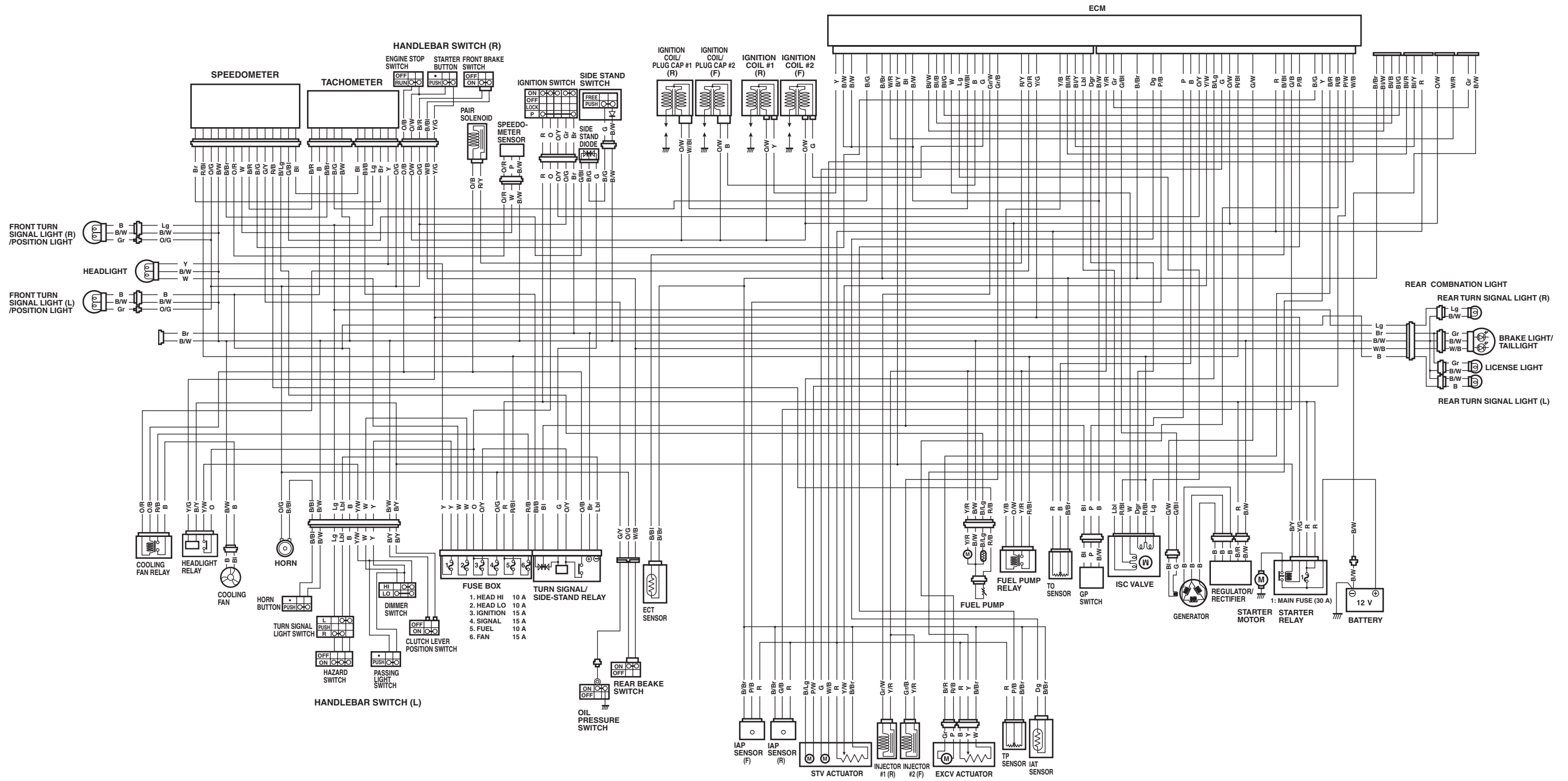

Prepared by

**SUZUKI MOTOR CORPORATION**

January, 2006

Part No. 99500-39290-01E

Printed in Japan

**SUZUKI MOTOR CORPORATION**





---

# Service Bulletin

---

MOTORCYCLE DIVISION

4-STROKE  
BULLETIN VS-VX-VZ-VL NO. 49  
DATE: 11/8/2006

**SUBJECT:** SERVICE MANUAL CORRECTION - PART IDENTIFICATION

**MODEL:** VZR1800K7

**REFERENCE:** VZR1800 SERVICE MANUAL (P/N 99500-39290-03E, Pages 6-7 & 10-35)

**NOTICE:**

This bulletin contains service manual correction information for the VZR1800K7. Insert a copy of each of the attached pages of this bulletin into the service manual at the appropriate page.

**AFFECTED DEPARTMENTS:**

The following departments in your dealership should be notified of this information:

Management    Service    Warranty    Sales    Parts    Accessories

American Suzuki Motor Corporation  
Technical Service Department  
Motorcycle / ATV / Scooter

# FUEL PUMP AND FUEL LEVEL GAUGE REMOVAL CONSTRUCTION

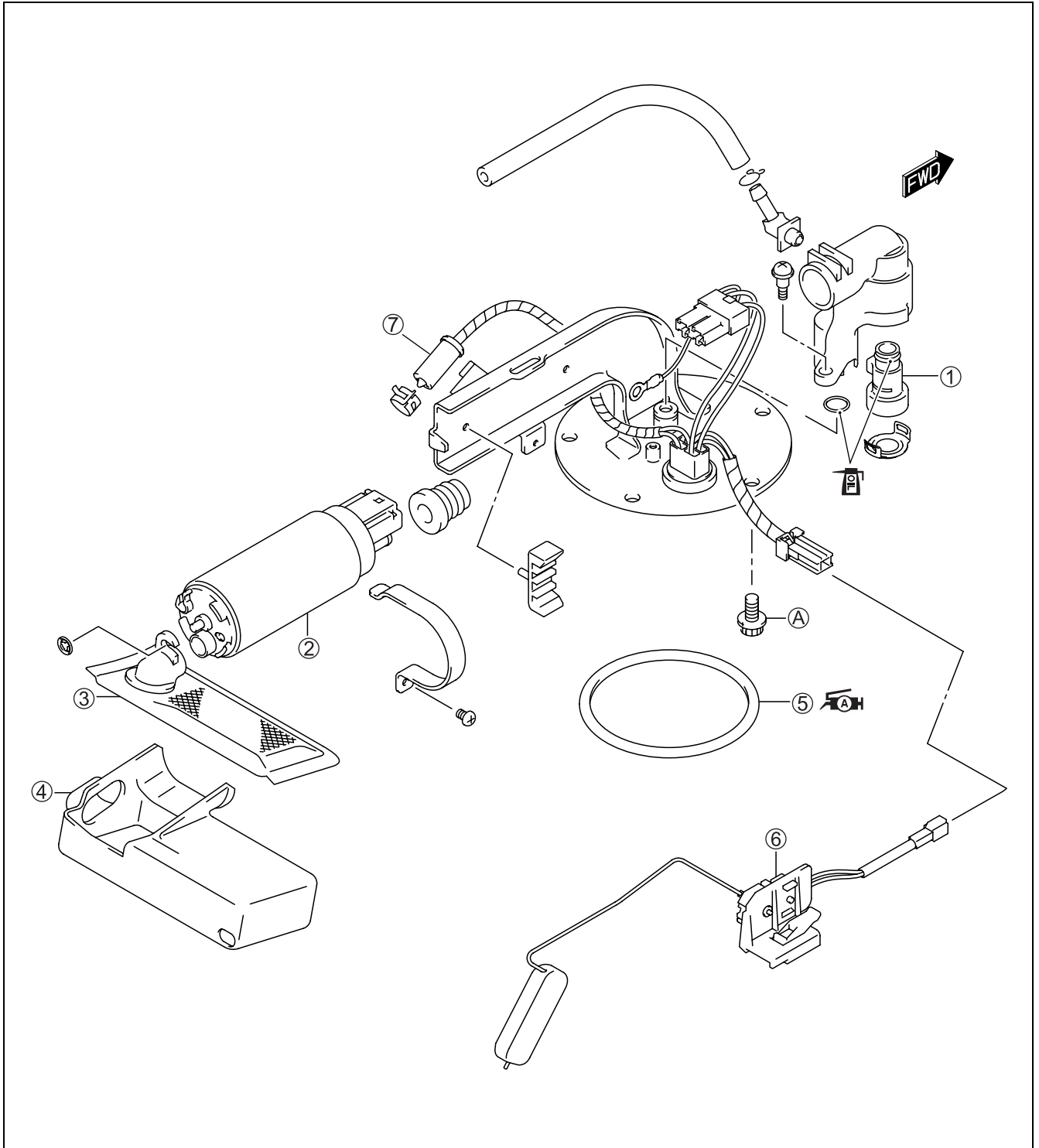

①	Regulator	⑤	O-ring
②	Fuel pump	⑥	Fuel level gauge
③	Fuel mesh filter	⑦	Thermistor
④	Filter cover	Ⓐ	Fuel pump mounting bolt



ITEM	N·m	kgf·m	lb·ft
Ⓐ	10	1.0	7.0

**FUEL LEVEL INDICATOR SWITCH (THERMISTOR) INSPECTION**

- Remove and disassemble the fuel pump assembly. (☞ 6-8)
- Connect 12 V battery and test bulb (12 V, 3.4 W) to the fuel level indicator switch as shown in the right illustration. The bulb should come on after one minutes if the switch is in good condition.

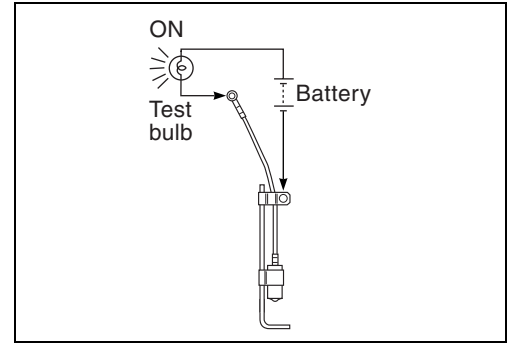

- When the switch is immersed in kerosene under the above condition, the bulb should go out. If the bulb remains lit, replace the unit with a new one.

**CAUTION**

- \* When the bulb turns off, immediately pick up the switch from kerosene.
- \* After the check has been completed, wash the switch with gasoline.

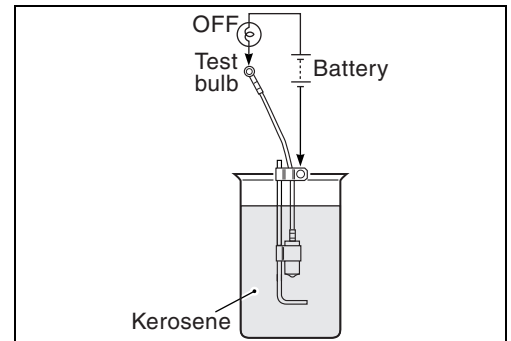
**FUEL LEVEL INDICATOR LIGHT INSPECTION**

If the fuel level indicator light does not function properly, check the fuel level indicator switch and its lead wire/coupler.

If the fuel level indicator switch and its lead wire/coupler are functioning properly, replace the tachometer with a new one.

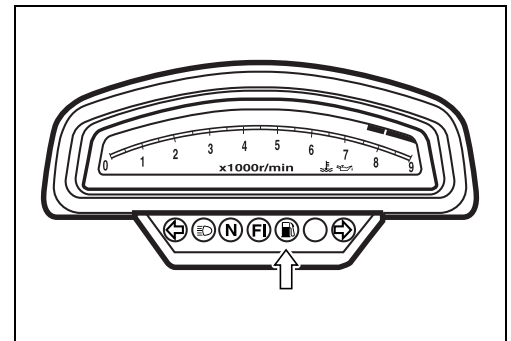

# Service Bulletin

MOTORCYCLE DIVISION

4-STROKE  
BULLETIN VS-VX-VZ-VL NO. 60  
DATE: 1/4/2008

**SUBJECT:** SERVICE MANUAL CORRECTIONS - VALVE SPRING SPECIFICATIONS AND CLUTCH WASHER

**MODEL:** VZR1800K6-K8

**REFERENCE:** VZR1800 SERVICE MANUAL (P/N 99500-39292-03E)  
Pages 3-38 and 11-26  
VZR1800 SERVICE MANUAL (P/N 99500-39292-03E, prior to 08/07 revision)  
Pages 3-21 and 3-95

**NOTICE:**

This bulletin contains service manual correction information for the VZR1800. Please change the valve spring specifications in your dealership service manual based upon the information provided below. Insert a copy of each of the attached pages with clutch washer information into your dealership service manual at the appropriate page.

## Pages 3-38 and 11-26

### VALVE SPRING

**DATA** Valve spring free length:  
Service limit (IN. & EX.): 40.5 mm (1.60 in)

Valve spring tension (IN. & EX.):  
Standard: 197 – 227 N  
(20.1 – 23.1 kgf/36.6 mm, 44.3 – 51.0 lbs/1.44 in)



to be corrected to

**DATA** Valve spring free length:  
Service limit (IN. & EX.): 39.8 mm (1.57 in)

Valve spring tension  
Standard (IN. & EX.): 137 – 157 N  
(14.0 – 16.0 kgf/36.6 mm, 30.9 – 35.3 lbs/1.44 in)

- Remove the thrust washer ①①.
- Remove the primary driven gear assembly ①②.

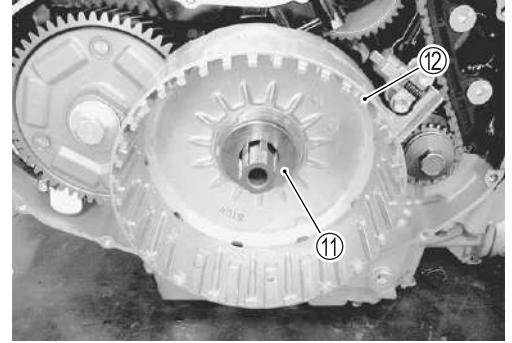

- Remove the needle roller bearing ①③, spacer ①④ and washer ①⑤.

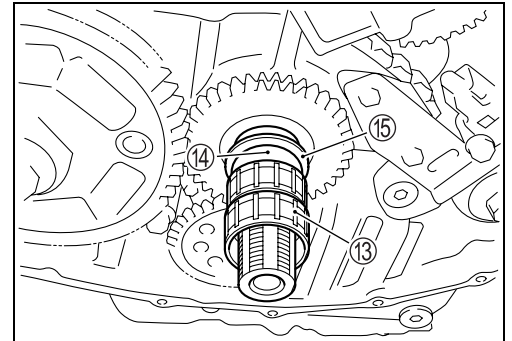

### REAR CAM CHAIN TENSION ADJUSTER

- Unlock the ratchet ① and insert the special tool.

 **09917-62430: Chain tensioner lock tool**

- Remove the rear cam chain tensioner No. 1 assy ②.

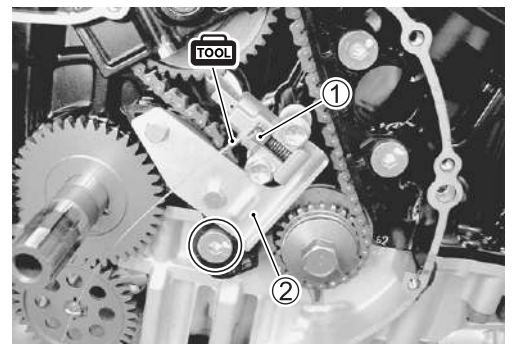

- Remove the cam chain guide No. 1 ③ and rear cam chain tension adjuster No. 1 ④.

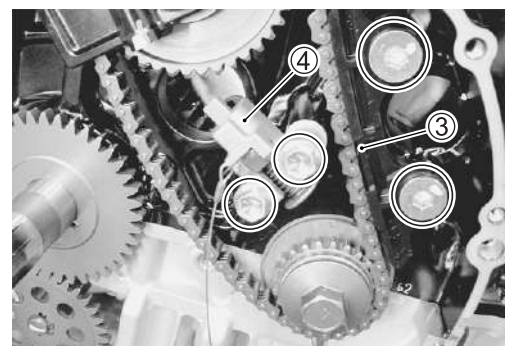

### REAR CAM CHAIN IDLER SPROCKET

- Remove the idler shaft ①.
- Disengage the cam chain No. 1 ② from the rear cam chain idler sprocket ③.

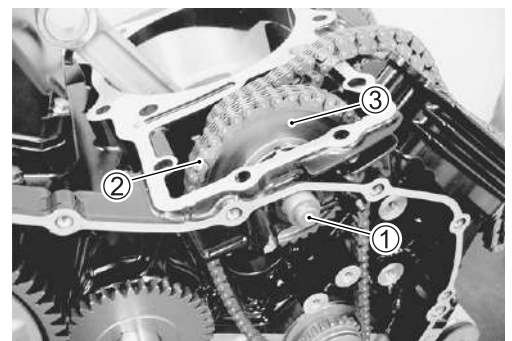

**CLUTCH**

- Install the washer ①, spacer ② and needle bearing ③ onto the countershaft.
- Apply engine oil to them.

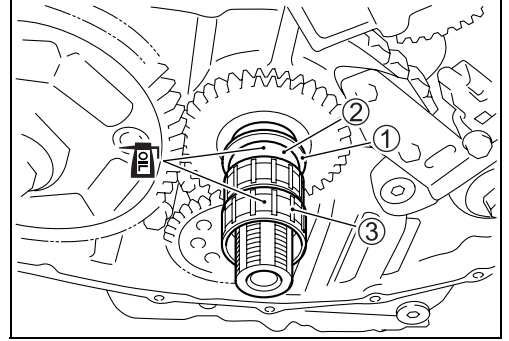

- Install the primary driven gear assembly ③ onto the countershaft.
- Install the thrust washer ④.

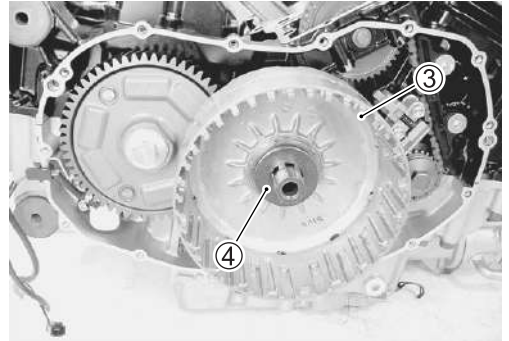

- Install the clutch sleeve hub assembly ⑤ onto the countershaft.
- Install the spring washer ⑥.

**NOTE:**

*The conical curve side of spring washer ⑥ faces outside.*

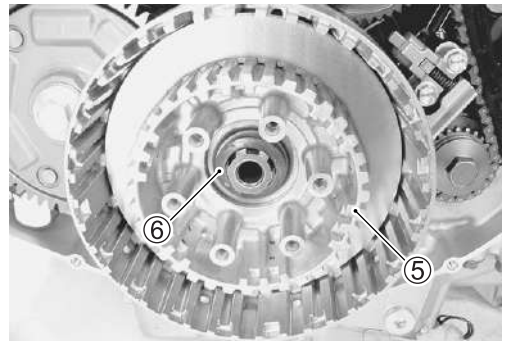

- Hold the generator rotor and tighten the clutch sleeve hub nut to the specified torque.

**🔧 Clutch sleeve hub nut: 95 N·m (9.5 kgf-m, 68.5 lb-ft)**

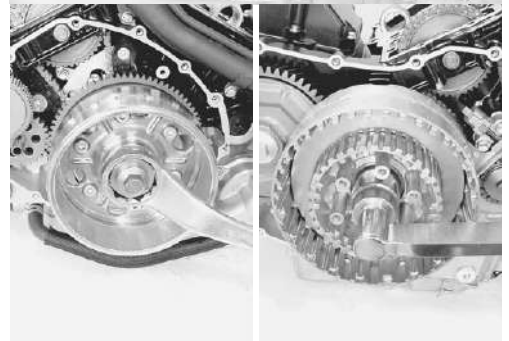

- Lock the clutch sleeve hub nut with a center punch.

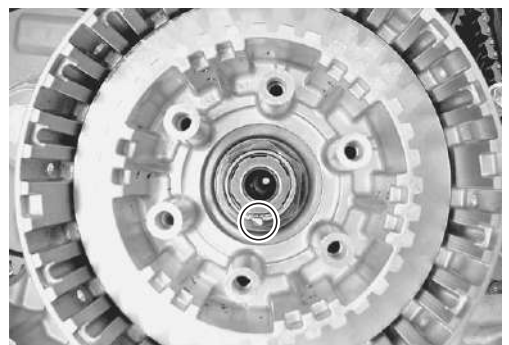





---

# Service Bulletin

---

MOTORCYCLE DIVISION

4-STROKE  
BULLETIN VS/VX/VZ/VL NO. 50  
DATE: 3/8/2007

**SUBJECT:**           **ADDITIONAL SERVICE MANUAL INFORMATION -  
CLUTCH CABLE PLAY ADJUSTMENT PROCEDURE MODIFICATION**

**MODEL:**           **VZR1800**

**REFERENCE:**       **VZR1800 SERVICE MANUAL (P/N 99500-39291-03E)**

**SUBJECT:**

This bulletin is to inform you of a modification to the clutch cable play adjustment procedure. Due to the high engine torque and heavy vehicle weight of the VZR1800, correct clutch cable play adjustment is important to prevent clutch slippage, particularly under heavy load. Inspect and adjust the clutch cable play during pre-delivery inspection and periodic maintenance using the following procedure. Insert a copy of each of the attached pages in your dealership's VZR1800 Service Manual at the appropriate page.

**AFFECTED DEPARTMENTS:**

The following departments in your dealership should be notified of this information:

Management     Service     Warranty     Sales     Parts     Accessories

American Suzuki Motor Corporation  
Technical Service Department  
Motorcycle / ATV / Scooter



### RADIATOR HOSES

- Remove the fuel tank. (☞ 6-3)
- Remove the frame head covers, radiator covers and radiator bottom cover. (☞ 9-6)
- Check to see the radiator hoses for crack, damage or engine coolant leakage.
- If any defects are found, replace the radiator hoses with new ones.

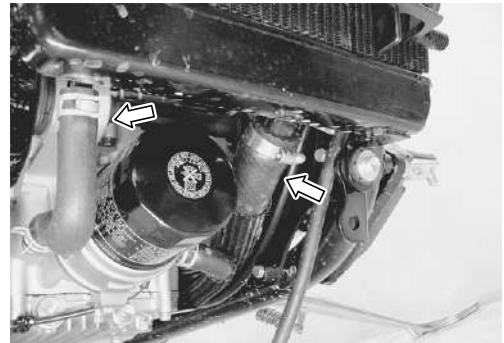
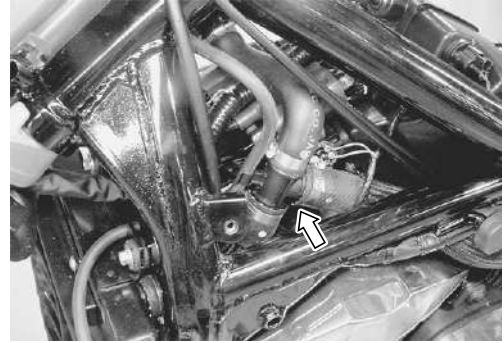

### CLUTCH CABLE PLAY

Inspect every 6 000 km (4 000 miles, 12 months).

- Remove the secondary gear case cover ①.
- Remove the clutch cable holder ② with the clutch cable.

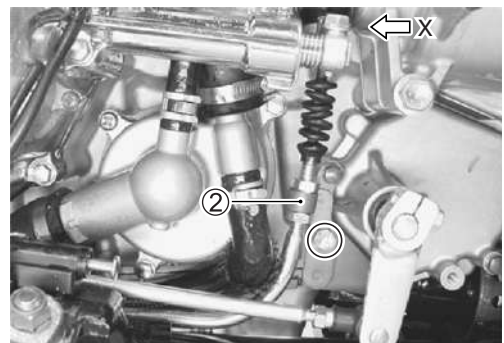
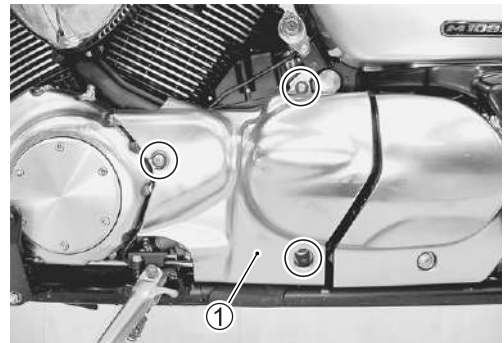

- Inspect the clutch release arm play ①.

**DATA** Clutch release arm play ①: **STD: 8.0 mm (0.31 in)**  
**LIMIT: 4.0 mm (0.16 in)**

- If the clutch release arm play ① less than the specification, adjust the clutch release screw as follows.
  - \* Drain engine oil.
  - \* Remove the muffler.
  - \* Remove the clutch cover.

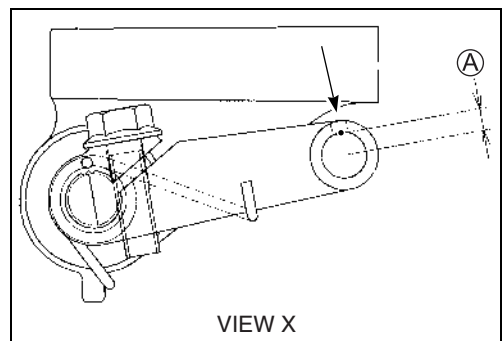

- \* Loosen the lock nut ③ and turn in the release screw ④ to feel resistance.
- \* From that position, turn out the release screw ④ 1 turn and tighten the lock nut ③ securely by holding the release screw ④.

**DATA Clutch release screw: 1 turn back**

- \* Install the clutch cover and muffler.
- \* Pour engine oil.
- \* Install the clutch cable holder ②.

- Loosen the lock nut ⑤.
- Turn in the adjuster ⑥ all the way into the clutch lever assembly.

- Loosen the lock nut ⑦, and turn the cable adjuster ⑧ to obtain 10 – 15 mm (0.4 – 0.6 in) of free play ⑨ at the clutch lever end.
- Tighten the lock nuts ⑤ and ⑦.

**DATA Clutch lever play ⑨: 10 – 15 mm (0.4 – 0.6 in)**

- Install the secondary gear case cover ①.

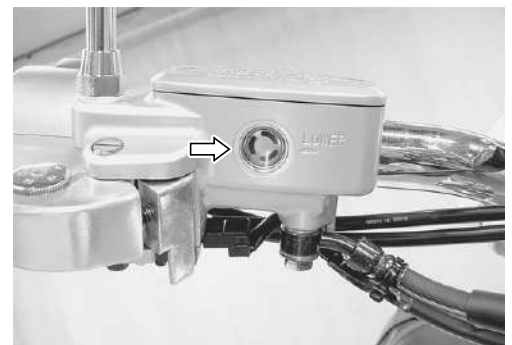
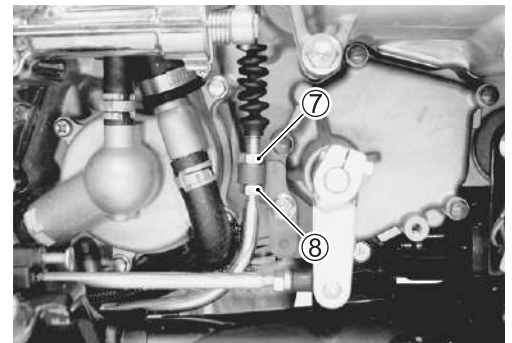
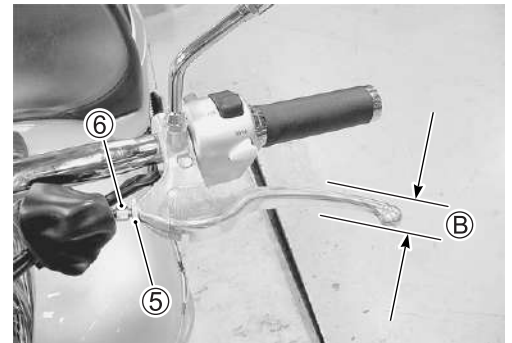
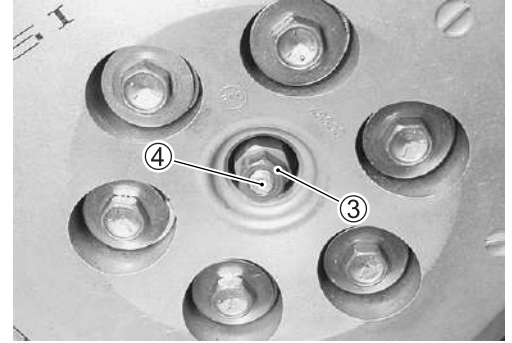

## BRAKE

**(BRAKE)**

Inspect initially at 1 000 km (600 miles, 2 months) and every 6 000 km (4 000 miles, 12 months) thereafter.

**(BRAKE HOSE AND BRAKE FLUID)**

Inspect every 6 000 km (4 000 miles, 12 months). Replace hoses every 4 years. Replace fluid every 2 years.

**BRAKE FLUID LEVEL CHECK**

- Keep the motorcycle upright and place the handlebars straight.
- Check the brake fluid level relative to the lower limit lines on the front and rear brake fluid reservoirs.
- When the level is below the lower limit line, replenish with brake fluid that meets the following specification.

**BF** Specification and classification: DOT 4

**⚠ WARNING**

- \* The brake system of this motorcycle is filled with a glycol-based brake fluid. Do not use or mix different types of fluid such as silicone-based and petroleum-based fluids. Do not use any brake fluid taken from old, used or unsealed containers. Never re-use brake fluid left over from the last servicing or stored for a long period of time.
- \* Brake fluid, if it leaks, will interfere with safe running and immediately discolor painted surfaces. Check the brake hoses and hose joints for cracks and fluid leakage before riding.

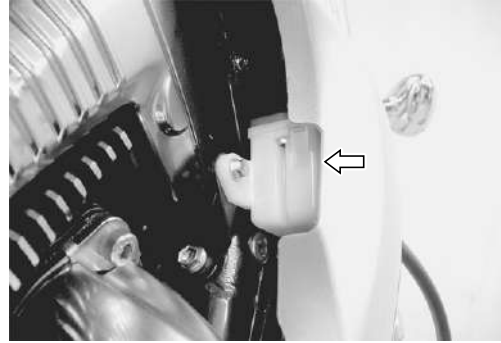

**BRAKE PADS**

**Front brake**

The extent of brake pad wear can be checked by observing the grooved limit line (A) on the pad. When the wear exceeds the grooved limit line, replace the pads with the new ones.

(👉 9-52)

**CAUTION**

Replace the brake pads as a set, otherwise braking performance will be adversely affected.

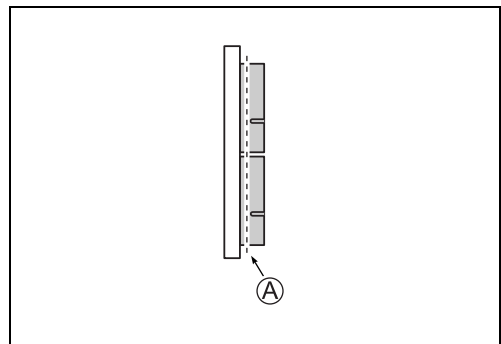
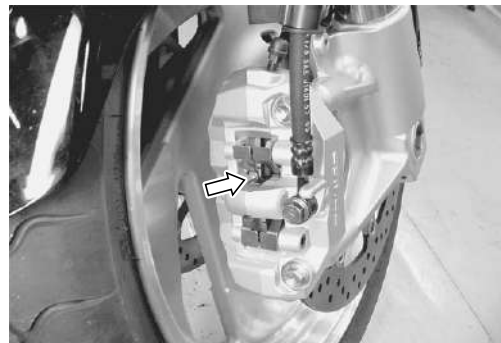

**Rear brake**

The extent of brake pad wear can be checked by observing the grooved limit line (A) on the pad. When the wear exceeds the grooved limit line, replace the pads with the new ones.

( 9-63)

**CAUTION**

Replace the brake pads as a set, otherwise braking performance will be adversely affected.

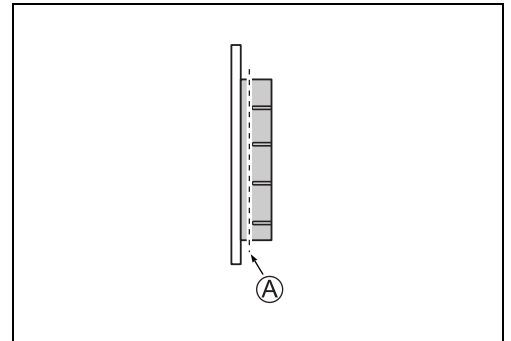
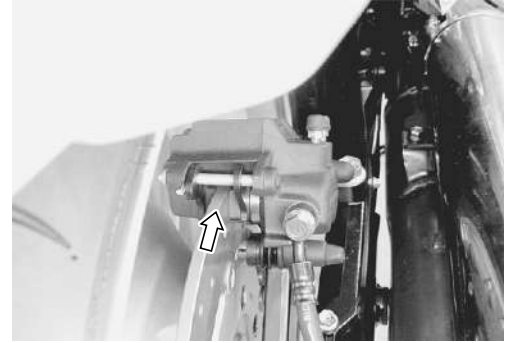

**BRAKE PEDAL HEIGHT**

- Loosen the lock nut ①.
- Turn the push rod ② until the brake pedal height becomes 25 – 35 mm (1.0 – 1.4 in) (A) below the top of the footrest.
- Tighten the lock nut ① securely.

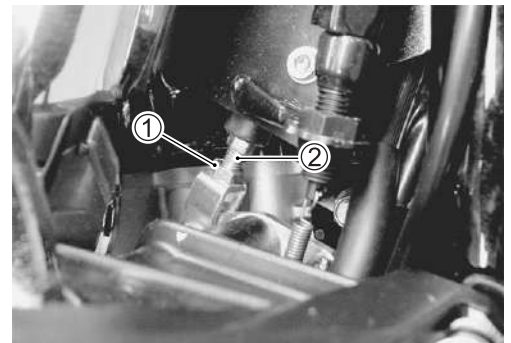

 **Rear brake master cylinder rod lock nut:**  
 18 N·m (1.8 kgf·m, 13.0 lb·ft)

 **Brake pedal height (A):**  
 Standard: 25 – 35 mm (1.0 – 1.4 in)

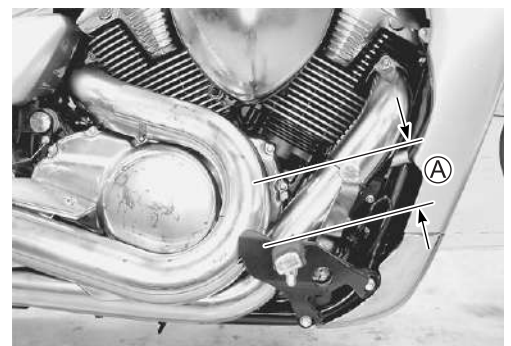

**BRAKE LIGHT SWITCH**

- Adjust the rear brake light switch so that the brake light will come on just before pressure is felt when the brake pedal is depressed.

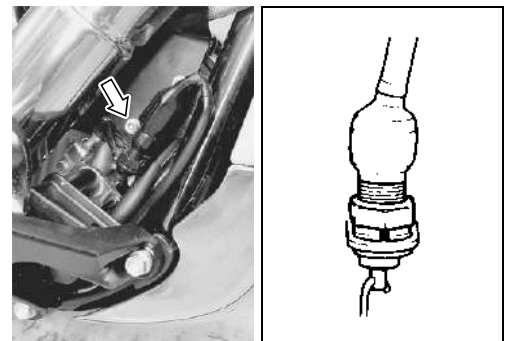



# Service Bulletin

MOTORCYCLE DIVISION

4-STROKE  
BULLETIN VS/VX/VZ/VL NO. 56  
DATE: 7/9/2007

**SUBJECT:** SUPPLEMENTAL SERVICE MANUAL INFORMATION

**MODEL:** VZR1800K8

**REFERENCE:** VZR1800 SERVICE MANUAL (P/N 99500-39291-03E)

**NOTICE:**

This bulletin contains additional technical information for the VZR1800K8. Please place a copy of this bulletin with your dealership's VZR1800 Service Manual.

**CONTENTS**

	PAGE
SPECIFICATIONS.....	2
SERVICE DATA .....	3
FI SYSTEM WIRING DIAGRAM .....	12
ECM TERMINAL .....	13
FAIL-SAFE FUNCTION .....	15
MALFUNCTION CODE AND DEFECTIVE CONDITION.....	16
“C44” (P0156) or “C64” (P0130) O2 SENSOR (O2S) CIRCUIT MALFUNCTION (FOR E-02, 19, 24, 51).....	18
“C49” (P1768) or “C61” (P1656) PAIR CONTROL SOLENOID VALVE CIRCUIT MALFUNCTION .....	21
WIRING DIAGRAM .....	22
CABLE ROUTING.....	24

**NOTE:**

Asterisk mark (\*) indicates the New K8 model specifications.

**AFFECTED DEPARTMENTS:**

The following departments in your dealership should be notified of this information:

- Management     Service     Warranty     Sales     Parts     Accessories

American Suzuki Motor Corporation  
Technical Service Department  
Motorcycle / ATV / Scooter



# SPECIFICATIONS

## DIMENSIONS AND DRY MASS

Overall length .....	2 450 mm (96.5 in)..... E-03, 33
	2 480 mm (97.6 in)..... Others
Overall width.....	875 mm (34.4 in)
Overall height .....	1 185 mm (46.7 in)
Wheelbase .....	1 710 mm (67.3 in)
Ground clearance.....	130 mm (5.1 in)
Seat height .....	705 mm (27.8 in)
Dry mass .....	* 321 kg (708 lbs)

## ENGINE

Type.....	Four-stroke, liquid-cooled, DOHC, 54-degree, V-twin
Number of cylinders .....	2
Bore.....	112.0 mm (4.409 in)
Stroke.....	90.5 mm (3.563 in)
Displacement .....	1 783 cm <sup>3</sup> (108.8 cu. in)
Compression ratio.....	10.5 : 1
Fuel system .....	Fuel injection
Air cleaner .....	Non-woven fabric element
Starter system.....	Electric
Lubrication system .....	Semi-Dry sump
Idle speed.....	900 ± 100 r/min

## DRIVE TRAIN

Clutch .....	Wet multi-plate type
Transmission .....	5-speed constant mesh
Gearshift pattern .....	1-down, 4-up
Primary reduction ratio.....	1.757 (55/55 × 58/33) ..... E-03, 28, 33
	* 1.647 (55/55 × 56/34) ..... Others
Gear ratios, Low .....	2.187 (35/16)
2nd .....	1.400 (28/20)
3rd .....	1.038 (27/26)
4th .....	0.827 (24/29)
Top.....	0.685 (24/35)
Final reduction ratio.....	2.823 (18/17 × 32/12)
Drive system.....	Shaft Drive

## CHASSIS

Front suspension .....	Inverted telescopic, coil spring, oil damped
Rear suspension .....	Link type, coil spring, oil damped
Front fork stroke .....	130 mm (5.1 in)
Rear wheel travel .....	118 mm (4.6 in)
Caster.....	31° 15'
Trail.....	124 mm (4.9 in)
Steering angle .....	37° (right & left)
Turning radius.....	3.3 m (10.8 ft)
Front brake .....	Disc brake, twin
Rear brake.....	Disc brake
Front tire size.....	130/70R18M/C 63 V, tubeless
Rear tire size.....	240/40R18M/C 79 V, tubeless

## ELECTRICAL

Ignition type .....	Electronic ignition (Transistorized)
Ignition timing .....	5° B.T.D.C. at 900 r/min
Spark plug .....	NGK CR8EK or DENSO U24ETR
Battery.....	12 V 64.8 kC (18 Ah)/10HR
Generator .....	Three-phase A.C. generator
Main fuse.....	30 A
Fuse .....	10/10/10/15/15/15 A
Headlight .....	12 V 60/55 W (H4)
Position light.....	12 V 5 W
Brake light/Taillight .....	LED
Front turn signal light.....	12 V 21/5 W ..... E-03, 28, 33
	12 V 21 W ..... Others
Rear turn signal light .....	12 V 21 W
License light .....	12 V 5 W
Speedometer light .....	LED
Tachometer light.....	LED
High beam indicator light.....	LED
Turn signal indicator light.....	LED
Neutral indicator light.....	LED
Coolant temperature/Oil pressure indicator light.....	LED
Fuel level indicator light .....	LED
FI indicato light .....	LED

## CAPACITIES

Fuel tank .....	18.5 L (4.9/4.1 US/Imp gal)..... E-33
	19.5 L (5.2/4.3 US/Imp gal)..... Others
Engine oil, oil change.....	3 400 ml (3.6/3.0 US/Imp qt)
with filter change .....	3 600 ml (3.8/3.2 US/Imp qt)
Overhaul.....	4 700 ml (5.0/4.1 US/Imp qt)
Final gear oil.....	200 – 220 ml (6.8/7.0 – 7.4/7.7 US/Imp oz)
Coolant.....	2.7 L (2.9/2.4 US/Imp qt)

## SERVICE DATA VALVE + GUIDE

Unit: mm (in)

ITEM	STANDARD		LIMIT
Valve diam.	IN.	42 (1.65)	—
	EX.	38 (1.50)	—
Tappet clearance (when cold)	IN.	0.09 – 0.16 (0.004 – 0.006)	—
	EX.	0.20 – 0.30 (0.008 – 0.012)	—
Valve guide to valve stem clearance	IN.	0.010 – 0.037 (0.0004 – 0.0015)	—
	EX.	0.030 – 0.057 (0.0012 – 0.0022)	—
Valve guide I.D.	IN. & EX.	6.000 – 6.012 (0.2362 – 0.2367)	—
Valve stem O.D.	IN.	5.975 – 5.990 (0.2352 – 0.2358)	—
	EX.	5.955 – 5.970 (0.2344 – 0.2350)	—
Valve stem deflection	IN. & EX.	—	0.35 (0.014)
Valve stem runout	IN. & EX.	—	0.05 (0.002)
Valve head thickness	IN. & EX.	—	0.5 (0.02)
Valve seat width	IN.	1.1 – 1.3 (0.043 – 0.051)	—
	EX.	1.4 – 1.6 (0.055 – 0.063)	—
Valve head radial runout	IN. & EX.	—	0.03 (0.001)
Valve spring free length	IN. & EX.	—	* 40.7 (1.60)
Valve spring tension	IN. & EX.	* 127 – 147 N (13.0 – 15.0 kgf, 28.7 – 33.1 lbs) at length 36.6 mm (1.44 in)	—

## CAMSHAFT + CYLINDER HEAD

Unit: mm (in)

ITEM	STANDARD		LIMIT
Cam height	IN.	40.880 – 40.930 (1.6094 – 1.6114)	40.580 (1.5976)
	EX.	40.880 – 40.930 (1.6094 – 1.6114)	40.580 (1.5976)
Camshaft journal oil clearance	IN. & EX.	0.032 – 0.066 (0.0013 – 0.0026)	0.150 (0.0059)
Camshaft journal holder I.D.	IN. & EX.	24.012 – 24.025 (0.9454 – 0.9459)	—
Camshaft journal O.D.	IN. & EX.	23.959 – 23.980 (0.9433 – 0.9441)	—



ITEM	STANDARD		LIMIT
Camshaft runout	IN. & EX.	—	0.10 (0.004)
Cam chain pin (at arrow "3")	18th pin		—
Cylinder head distortion	—		0.05 (0.002)

## CYLINDER + PISTON + PISTON RING

Unit: mm (in)

ITEM	STANDARD		LIMIT
Compression pressure (Automatic de-comp. actuated)	1 100 – 1 500 kPa (11.0 – 15.0 kgf/cm <sup>2</sup> , 156 – 213 psi)		800 kPa (8.0 kgf/cm <sup>2</sup> , 114 psi)
Compression pressure difference	—		200 kPa (2.0 kgf/cm <sup>2</sup> , 28 psi)
Piston to cylinder clearance	0.018 – 0.043 (0.0007 – 0.0017)		0.120 (0.0047)
Cylinder bore	112.000 – 112.015 (4.4094 – 4.4100)		Nicks or Scratches
Piston diam.	111.967 – 111.983 (4.4081 – 4.4088) Measure at 10 mm (0.4 in) from the skirt end.		111.880 (4.4047)
Cylinder distortion	—		0.05 (0.002)
Piston ring free end gap	1st	Approx. 15.7 (0.62)	12.6 (0.50)
	2nd	Approx. 14.5 (0.57)	11.6 (0.46)
Piston ring end gap	1st	0.10 – 0.25 (0.004 – 0.010)	0.50 (0.020)
	2nd	0.10 – 0.25 (0.004 – 0.010)	0.50 (0.020)
Piston ring to groove clearance	1st	—	0.180 (0.0071)
	2nd	—	0.150 (0.0059)
Piston ring groove width	1st	0.93 – 0.95 (0.0366 – 0.0374)	—
		1.55 – 1.57 (0.0610 – 0.0618)	—
	2nd	1.21 – 1.23 (0.0476 – 0.0484)	—
	Oil	2.51 – 2.53 (0.0988 – 0.0996)	—
Piston ring thickness	1st	0.86 – 0.91 (0.034 – 0.036)	—
		1.38 – 1.40 (0.054 – 0.055)	—
	2nd	1.17 – 1.19 (0.046 – 0.047)	—
Piston pin bore I.D.	23.002 – 23.008 (0.9056 – 0.9058)		23.030 (0.9067)
Piston pin O.D.	22.995 – 23.000 (0.9053 – 0.9055)		22.980 (0.9047)

**CONROD + CRANKSHAFT**

Unit: mm (in)

ITEM	STANDARD	LIMIT
Conrod small end I.D.	23.010 – 23.018 (0.9059 – 0.9062)	23.040 (0.9071)
Conrod big end side clearance	0.100 – 0.200 (0.0039 – 0.0078)	0.30 (0.012)
Conrod big end width	23.95 – 24.00 (0.943 – 0.945)	—
Crank pin width	24.10 – 24.15 (0.9488 – 0.9508)	—
Conrod big end oil clearance	0.032 – 0.056 (0.0013 – 0.0022)	0.080 (0.0031)
Crank pin O.D.	54.976 – 55.000 (2.1644 – 2.1654)	—
Crankshaft journal oil clearance	0.016 – 0.034 (0.0006 – 0.0013)	0.080 (0.0031)
Crankshaft journal O.D.	54.982 – 55.000 (2.1646 – 2.1654)	—
Crankshaft thrust bearing thickness	2.250 – 2.550 (0.0886 – 0.1004)	—
Crankshaft thrust clearance	0.100 – 0.200 (0.0039 – 0.0079)	—
Crankshaft runout	—	0.05 (0.002)

**OIL PUMP**

ITEM	STANDARD	LIMIT
Oil pressure (at 60 °C, 140 °F)	Above 400 kPa (4.0 kgf/cm <sup>2</sup> , 57 psi) Below 700 kPa (7.0 kgf/cm <sup>2</sup> , 100 psi) at 3 000 r/min	—

**CLUTCH**

Unit: mm (in)

ITEM	STANDARD	LIMIT
Clutch cable play	10 – 15 (0.4 – 0.6)	—
Clutch release screw	1 turn back	—
Drive plate thickness	No. 1	3.52 – 3.68 (0.139 – 0.145)
	No. 2	1.92 – 2.08 (0.076 – 0.082)
Driven plate thickness	No. 1	2.82 – 2.98 (0.111 – 0.117)
	No. 2	3.32 – 3.48 (0.131 – 0.137)
Driven plate claw width	No. 1 & No. 2	7.96 – 8.15 (0.313 – 0.321)
Driven plate distortion	—	0.10 (0.004)
Clutch spring free length	51.3 (2.02)	48.8 (1.92)

## THERMOSTAT + RADIATOR + FAN + COOLANT

ITEM	STANDARD		LIMIT
Thermostat valve opening temperature	Approx. 88 °C (190 °F)		—
Thermostat valve lift	Over 8.0 mm (0.31 in) at 100 °C (212 °F)		—
Engine coolant temperature sensor resistance	20 °C (68 °F)	Approx. 2.45 kΩ	—
	50 °C (122 °F)	Approx. 0.811 kΩ	—
	80 °C (176 °F)	Approx. 0.318 kΩ	—
	110 °C (230 °F)	Approx. 0.142 kΩ	—
Radiator cap valve opening pressure	93 – 123 kPa (0.93 – 1.23 kgf/cm <sup>2</sup> , 13.2 – 17.5 psi)		—
Cooling fan operating temperature	OFF → ON	Approx. 105 °C (221 °F)	—
	ON → OFF	Approx. 100 °C (212 °F)	—
Engine coolant type	Use an anti-freeze/coolant compatible with aluminum radiator, mixed with distilled water only, at the ratio of 50:50.		—
Engine coolant	Reservoir tank side	Approx. 250 ml (0.3/0.2 US/Imp qt)	—
	Engine side	Approx. 2 450 ml (2.6/2.2 US/Imp qt)	—

## DRIVE TRAIN

Unit: mm (in) Expect ratio

ITEM	STANDARD		LIMIT
Primary reduction ratio	E-03, 28, 33	1.757 (55/55 × 58/33)	—
	Others	* 1.647 (55/55 × 56/34)	—
Secondary reduction ratio	1.058 (18/17)		—
Final reduction ratio	2.666 (32/12)		—
Gear ratio	Low	2.187 (35/16)	—
	2nd	1.400 (28/20)	—
	3rd	1.038 (27/26)	—
	4th	0.827 (24/29)	—
	Top	0.685 (24/35)	—
Shift fork to groove clearance	0.1 – 0.3 (0.004 – 0.012)		0.50 (0.020)
Shift fork groove width	5.0 – 5.1 (0.197 – 0.201)		—
Shift fork thickness	4.8 – 4.9 (0.189 – 0.193)		—
Gearshift lever height	45 – 55 (1.8 – 2.2)		—

**DRIVELINE/AXLE**

Unit: mm (in)

ITEM	STANDARD/SPECIFICATION	LIMIT
Secondary bevel gear backlash	0.03 – 0.15 (0.001 – 0.006)	—
Final bevel gear backlash	0.08 – 0.16 (0.003 – 0.006)	—
Damper spring free length	—	64.6 (2.54)
Final gear oil type	Hypoide gear oil SAE #90, API grade GL-5	—
Final gear oil capacity	200 – 220 ml (6.8/7.0 – 7.4/7.7 US/lmp oz)	—

**INJECTOR + FUEL PUMP + FUEL PRESSURE REGULATOR**

ITEM	SPECIFICATION	NOTE
Injector resistance	11 – 13 $\Omega$ at 23 °C (73 °F)	
Fuel pump discharge amount	168 ml and more (5.7/5.9 US/lmp oz) for 10 seconds at 300 kPa (3.0 kgf/cm <sup>2</sup> , 43 psi)	
Fuel pressure regulator operating set pressure	Approx. 300 kPa (3.0 kgf/cm <sup>2</sup> , 43 psi)	

**FI-SENSORS**

ITEM	SPECIFICATION		NOTE
CKP sensor resistance	190 – 290 $\Omega$		
CKP sensor peak voltage	1.5 V and more		When cranking
IAP sensor input voltage (F & R)	4.5 – 5.5 V		
IAP sensor output voltage (F & R)	Approx. 2.6 V at idle speed		
TP sensor input voltage	4.5 – 5.5 V		
TP sensor resistance	Closed	Approx. 1.1 k $\Omega$	
	Opened	Approx. 4.3 k $\Omega$	
TP sensor output voltage	Closed	Approx. 1.1 V	
	Opened	Approx. 4.3 V	
ECT sensor input voltage	4.5 – 5.5 V		
ECT sensor output voltage	0.15 – 4.84 V		
ECT sensor resistance	Approx. 2.45 k $\Omega$ at 20 °C (68 °F)		
IAT sensor input voltage	4.5 – 5.5 V		
IAT sensor output voltage	0.15 – 4.84 V		
IAT sensor resistance	Approx 2.45 k $\Omega$ at 20 °C (68 °F)		
TO sensor resistance	16.5 – 22.3 k $\Omega$		
TO sensor voltage	Normal	0.4 – 1.4 V	
	Leaning	3.7 – 4.4 V	When leaning 65°
GP switch voltage	0.6 V and more		From 1st to top
Injector voltage	Battery voltage		
Ignition coil primary peak voltage	250 V and more		When cranking
Ignition coil/Plug cap primary peak voltage	80 V and more		When cranking
STP sensor input voltage	4.5 – 5.5 V		
STP sensor resistance	Closed	Approx. 0.6 k $\Omega$	
	Opened	Approx. 4.2 k $\Omega$	

ITEM	SPECIFICATION		NOTE
STP sensor output voltage	Closed	Approx. 0.6 V	
	Opened	Approx. 4.2 V	
STV actuator resistance	Approx. 7 $\Omega$		
EXCVA position sensor input voltage	4.5 – 5.5 V		
EXCVA position sensor resistance	Approx. 3.1 k $\Omega$		At adjustment position
EXCVA position sensor output voltage	Closed	0.5 – 1.5 V	
	Opened	3.5 – 4.5 V	
Oxygen sensor output voltage	0.4 V and less at idle speed		E-02, 19, 24, 51
	0.6 V and more at 3 000 r/min		E-02, 19, 24, 51
Oxygen sensor resistance	4.0 – 5.5 $\Omega$ at 23 °C (73.4 °F)		E-02, 19, 24, 51
PAIR solenoid valve resistance	18 – 22 $\Omega$ at 20 – 30 °C (68 – 86 °F)		

## THROTTLE BODY

ITEM	SPECIFICATION
I.D. No.	* 48G3 (For E-33), 48G2 (Others)
Bore size	56 mm
Idle r/min	900 $\pm$ 100 r/min/Warmed engine
Throttle cable play	2.0 – 4.0 mm (0.08 – 0.16 in)

## ELECTRICAL

Unit: mm (in)

ITEM	SPECIFICATION		NOTE
Firing order	1-2		
Spark plug	Type	NGK: CR8EK DENSO: U24ETR	
	Gap	0.6 – 0.7 (0.024 – 0.028)	
Spark performance	Over 8 (0.3) at 1 atm.		
CKP sensor resistance	190 – 290 $\Omega$		BI – G
Ignition coil resistance	Primary	1.8 – 3.0 $\Omega$	$\oplus$ tap – $\ominus$ tap
	Secondary	16 – 26 k $\Omega$	$\ominus$ tap – Plug cap
Ignition coil/Plug cap resistance	Primary	1.1 – 1.9 $\Omega$	$\oplus$ tap – $\ominus$ tap
	Secondary	10.8 – 16.2 k $\Omega$	Plug cap – $\ominus$ tap
CKP sensor peak voltage	1.5 V and more		$\oplus$ BI $\ominus$ G
Ignition coil primary peak voltage	250 V and more		Front $\oplus$ : G $\ominus$ : Ground Rear $\oplus$ : Y $\ominus$ : Ground
Ignition coil/Plug cap primary peak voltage	80 V and more		Front $\oplus$ : B $\ominus$ : Ground Rear $\oplus$ : W/BI $\ominus$ : Ground
Generator coil resistance	0.2 – 1.5 $\Omega$		B – B
Generator Max. output	Approx. 400 W at 5 000 r/min		

ITEM		SPECIFICATION		NOTE
Generator no-load voltage (When engine is cold)		70 V (AC) and more at 5 000 r/min		
Regulated voltage		14.0 – 15.5 V at 5 000 r/min		
Starter relay resistance		3 – 6 Ω		
Battery	Type designation	FTZ16-BS		
	Capacity	12 V 64.8 kC (18 Ah)/10 HR		
Fuse size	Headlight	HI	10 A	
		LO	10 A	
	Fuel	10 A		
	Ignition	15 A		
	Turn signal	15 A		
	Fan motor	15 A		
	Main	30 A		
	Starter motor brush length		Standard	12.5 (0.49)
Limit			6.0 (0.24)	

## WATTAGE

Unit: W

ITEM		SPECIFICATION	
		E-03, 28, 33	E-02, 19, 24, 51
Headlight	HI	60	←
	LO	55	←
Position light			5
Brake light/Taillight		LED	←
Front turn signal light/Position light		21/5	
Front turn signal light			21
Rear turn signal light		21	←
Speedometer		LED	←
Tachometer		LED	←
Turn signal indicator light		LED	←
High beam indicator light		LED	←
Neutral indicator light		LED	←
Fuel level indicator light		LED	←
Coolant temperature/Oil pressure indicator light		LED	←
FI indicator light		LED	←
License light		5	←

# BRAKE + WHEEL

Unit: mm (in)

ITEM		STANDARD		LIMIT
Rear brake pedal height		25 – 35 (1.0 – 1.4)		—
Brake disc thickness		Front	5.0 ± 0.2 (0.197 ± 0.008)	4.5 (0.18)
		Rear	7 <sup>0</sup> <sub>-0.4</sub> (0.276 <sup>0</sup> <sub>-0.016</sub> )	6.3 (0.25)
Brake disc runout (Front & Rear)		—		0.30 (0.012)
Master cylinder bore		Front	15.870 – 15.913 (0.6248 – 0.6265)	—
		Rear	14.000 – 14.043 (0.5512 – 0.5529)	—
Master cylinder piston diam.		Front	15.827 – 15.854 (0.6231 – 0.6242)	—
		Rear	13.957 – 13.984 (0.5495 – 0.5506)	—
Brake caliper cylinder bore	Leading	Front	30.280 – 30.356 (1.1921 – 1.1951)	—
	Trailing		34.010 – 34.086 (1.3390 – 1.3420)	—
	Leading & Trailing	Rear	30.230 – 30.306 (1.1902 – 1.1931)	—
Brake caliper piston diam.	Leading	Front	30.150 – 30.200 (1.1870 – 1.1890)	—
	Trailing		33.884 – 33.934 (1.3340 – 1.3360)	—
	Leading & Trailing	Rear	30.150 – 30.200 (1.1870 – 1.1890)	—
Brake fluid type		DOT 4		—
Wheel rim runout (Front & Rear)		Axial	—	2.0 (0.08)
		Radial	—	2.0 (0.08)
Wheel axle runout		Front	—	0.25 (0.010)
		Rear	—	0.25 (0.010)
Wheel rim size		Front	18M/C × MT 3.50	—
		Rear	18M/C × MT 8.50	—
Tire size		Front	130/70R18M/C 63V, tubeless	—
		Rear	240/40R18M/C 79V, tubeless	—
Tire type		Front	DUNLOP: D221FA	—
		Rear	DUNLOP: D221	—
Tire tread depth		Front	—	1.6 (0.06)
		Rear	—	2.0 (0.08)



## SUSPENSION

Unit: mm (in)

ITEM	STANDARD	LIMIT
Front fork stroke	130 (5.1)	—
Front fork spring free length	* 395 (15.6)	* 387 (15.2)
Front fork inner tube O.D.	46 (1.8)	—
Front fork oil level (without spring, inner tube fully compressed)	* 122 (4.8)	—
Front fork oil type	SUZUKI FORK OIL L01 or an equivalent fork oil	—
Front fork oil capacity (each leg)	* 700 ml (23.7/24.6 US/lmp oz)	—
Rear shock absorber spring adjuster	4/7	—
Rear wheel travel	118 (4.6)	—
Swingarm pivot shaft runout	—	0.3 (0.01)

## TIRE PRESSURE

COLD INFLATION TIRE PRESSURE	SOLO RIDING			DUAL RIDING		
	kPa	kgf/cm <sup>2</sup>	psi	kPa	kgf/cm <sup>2</sup>	psi
FRONT	250	2.50	36	250	2.50	36
REAR	290	2.90	42	290	2.90	42

## FUEL + OIL

ITEM	SPECIFICATION	NOTE
Fuel type	Use only unleaded gasoline of at least 90 pump octane (R/2 + M/2). Gasoline containing MTBE (Methyl Tertiary Butyl Ether), less than 10% ethanol, or less than 5% methanol with appropriate cosolvents and corrosion inhibitor is permissible.	E-03, 28, 33
	Gasoline used should be graded 95 octane or higher. An unleaded gasoline is recommended.	The others
Fuel tank capacity	18.5 L (4.9/4.1 US/lmp gal)	E-33
	19.5 L (5.2/4.3 US/lmp gal)	The others
Engine oil type	SAE 10W-40, API SF/SG or SH/SJ with JASO MA	
Engine oil capacity	Change	3 400 ml (3.6/3.0 US/lmp qt)
	Filter change	3 600 ml (3.8/3.2 US/lmp qt)
	Overhaul	4 700 ml (5.0/4.1 US/lmp qt)

# FI SYSTEM WIRING DIAGRAM

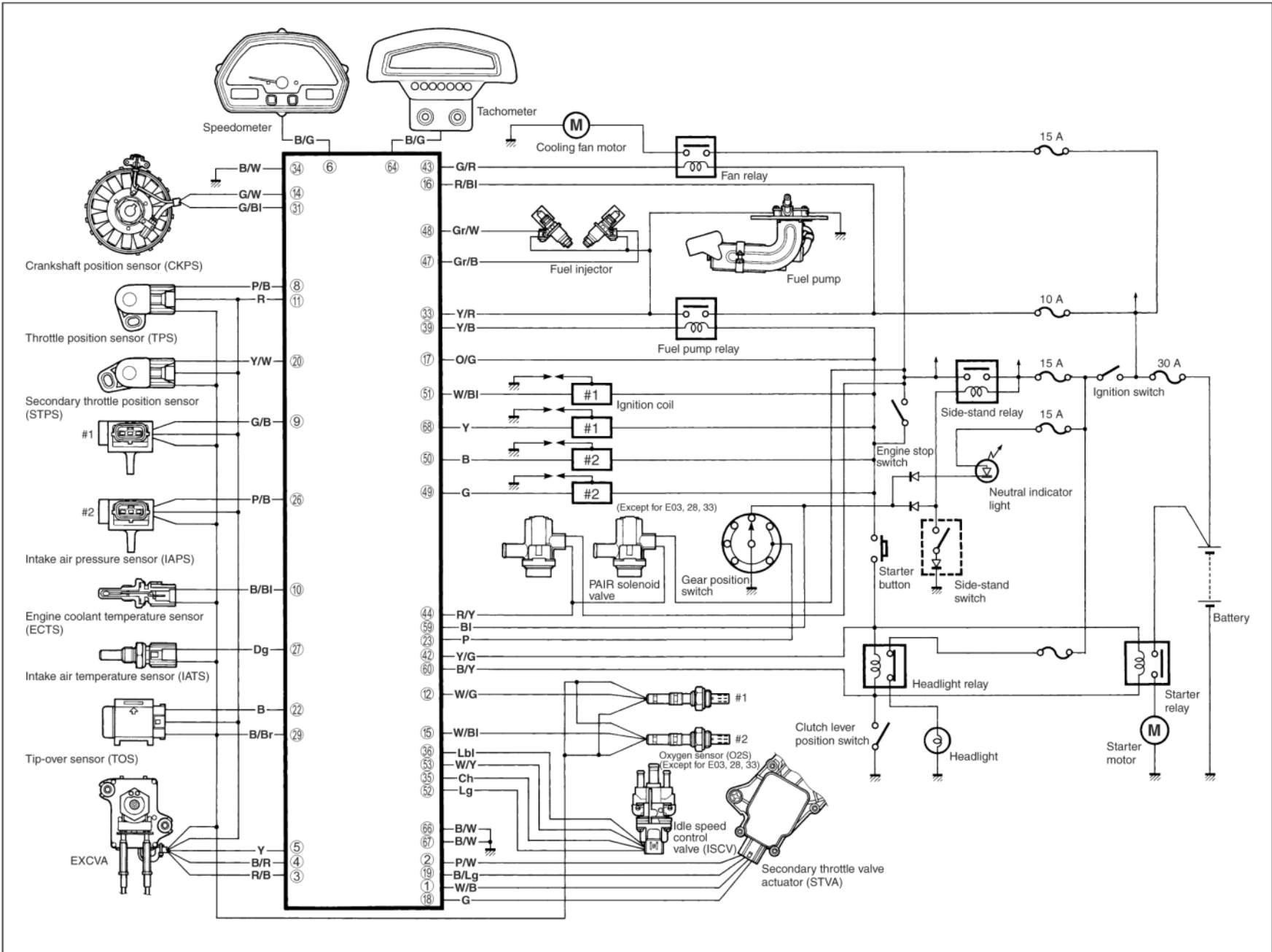

## ECM TERMINAL

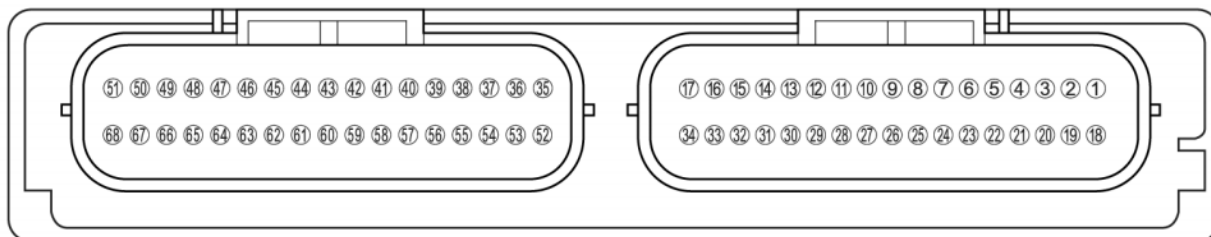

TERMINAL NO.	CIRCUIT	TERMINAL NO.	CIRCUIT
①	STVA signal (STVA. 2A)	⑱	STVA signal (STVA. 2B)
②	STVA signal (STVA. 1A)	⑲	STVA signal (STVA. 1B)
③	EXCVA power (MO-)	⑳	STP sensor signal (STP)
④	EXCVA power (MO+)	㉑	Ignition switch signal
⑤	EXCVA position sensor (MPS)	㉒	TO sensor signal (TOS)
⑥	Serial data for speedometer	㉓	GP switch signal (GP)
⑦	Blank	㉔	Blank
⑧	TP sensor signal (TP)	㉕	Blank
⑨	IAP sensor signal #1 (IAP. 1)	㉖	IAP sensor signal #2 (IAP. 2)
⑩	ECT sensor signal (ECT)	㉗	IAT sensor signal (IAT)
⑪	Power source for sensors (VCC)	㉘	Blank
⑫	O2 sensor signal #1 (O2S) [For E-02, 19, 24, 51]	㉙	Sensors ground (E2)
⑬	Blank	㉚	Blank
⑭	CKP sensor signal (CKP+)	㉛	CKP sensor signal (CKP-)
⑮	O2 sensor signal #2 (O2S) [For E-02, 19, 24, 51]	㉜	Serial data for self-diagnosis
⑯	Power source for back-up	㉝	Power source for fuel injector (VM)
⑰	Power source	㉞	ECM ground (E1)

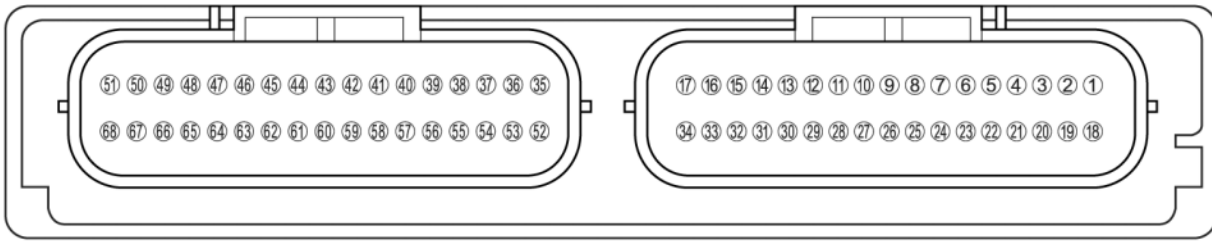

TERMINAL NO.	CIRCUIT	TERMINAL NO.	CIRCUIT
35	ISC signal (ISC, 2A)	52	ISC signal (ISC, 2B)
36	ISC signal (ISC, 1A)	53	ISC signal (ISC, 1B)
37	—	54	—
38	—	55	—
39	Fuel pump relay (FP Relay)	56	—
40	—	57	—
41	Blank	58	Mode select switch
42	Starter relay	59	Neutral switch
43	Cooling fan relay (FAR)	60	Clutch position switch
44	Rear cylinder PAIR control solenoid #1 valve (PAIR. #1)	61	—
45	Blank	62	—
46	Blank	63	Blank
47	Fuel injector #2 (#21)	64	Tachometer
48	Fuel injector #1 (#11)	65	—
49	Ignition coil #2	66	Ground
50	Ignition coil #2	67	Ground for ignition system
51	Ignition coil #1	68	Ignition coil #1

## FAIL-SAFE FUNCTION

FI system is provided with fail-safe function to allow the engine to start and the motorcycle to run in a minimum performance necessary even under malfunction condition.

ITEM	FAIL-SAFE MODE	STARTING ABILITY	RUNNING ABILITY
IAP sensor	Intake air pressure is fixed to 760 mmHg.	“YES”	“YES”
TP sensor	The throttle opening is fixed to full open position.	“YES”	“YES”
ECT sensor	Engine coolant temperature value is fixed to 80 °C (176 °F).	“YES”	“YES”
IAT sensor	Intake air temperature value is fixed to 40 °C (104 °F).	“YES”	“YES”
Ignition signal	#1.1 or #1.2 Ignition-off	“YES”	“YES”
		#1 cylinder can run.	
	#2.1 or #2.2 Ignition-off	“YES”	“YES”
		#2 cylinder can run.	
Injection signal	#1 Fuel-cut	“YES”	“YES”
		#2 cylinder can run.	
	#2 Fuel-cut	“YES”	“YES”
		#1 cylinder can run.	
Secondary throttle valve actuator	Secondary throttle valve is fixed to full close position. When motor disconnection or lock occurs, power from ECM is shut off.	“YES”	“YES”
STP sensor	Secondary throttle valve is fixed to full close position.	“YES”	“YES”
Gear position signal	Gear position signal is fixed to 5th gear.	“YES”	“YES”
Oxygen sensor (E-02, 19, 24, 51)	Fuel-air compensation ratio is fixed to normal condition.	“YES”	“YES”
PAIR control solenoid valve	ECM stops controlling PAIR control solenoid valve.	“YES”	“YES”
EXCV actuator	EXCV actuator is fixed to full open position. When motor disconnection or lock occurs, power from ECM is shut off.	“YES”	“YES”
ISC valve	When motor disconnection or lock occurs, power from ECM is shut off.	“YES”	“YES”

The engine can start and can run even if the above signal is not received from each sensor. But, the engine running condition is not complete, providing only emergency help (by fail-safe circuit). In this case, it is necessary to bring the motorcycle to the workshop for complete repair.

When two ignition signals or two injector signals are not received by ECM, the fail-safe circuit can not work and ignition or injection is stopped.

## MALFUNCTION CODE AND DEFECTIVE CONDITION

DTC No.		DETECTED ITEM	DETECTED FAILURE CONDITION	CHECK FOR
C40 P0505	H	ISC valve	ISC valve motor current is higher than specified value.	ISC valve circuit shorted to BATT or ground circuit open
	L		ISC valve motor circuit is open.	ISC valve circuit open or BATT circuit open
P0506			Idle speed is lower than the desired idle speed.	W/Y or Lg wire open or ground circuit open Air circuit clogged ISC valve is fixed
P0507			Idle speed is higher than the desired idle speed.	W/Y or Dgr wire open or shorted or ground circuit open ISC valve is fixed ISC valve hose connection
C41		Fuel pump relay	No voltage is applied to the fuel pump, although fuel pump relay is turned ON, or voltage is applied to fuel pump although fuel pump relay is turned OFF.	Fuel pump relay, lead wire/coupler connection, power source to fuel pump relay and fuel injectors
P0230				
P0230	H		Voltage is applied to fuel pump although fuel pump relay is turned OFF.	Fuel pump relay switch circuit shorted to power source Fuel pump relay (switch side)
	L	No voltage is applied to the fuel pump, although fuel pump relay is turned ON.	Fuel pump relay circuit open or short Fuel pump relay (coil side).	
C42	Ignition switch	Ignition switch signal is not input to ECM.	Ignition switch, lead wire/coupler	
P1650				
C44/C64	O2 sensor (E-02, 19, 24, 51)	O2 sensor output voltage is not input to ECM during engine operation and running condition. (Sensor voltage < 0.45 V) In other than the above value, C44 (P0156/0130) is indicated.	O2 sensor circuit open or shorted to ground	
P0156/P0130				

DTC No.	DETECTED ITEM	DETECTED FAILURE CONDITION	CHECK FOR	
C46	Exhaust control valve actuator	EXCVA position sensor produces following voltage. $0.1\text{ V} \leq \text{sensor voltage} < 4.9\text{ V}$ In other than the above range, C46 (P1657) is indicated. When no actuator control signal is supplied from the ECM, communication signal does not reach ECM or operation voltage does not reach EXCVA motor, C46 (P1658) is indicated. EXCVA can not operate.	EXCVA, EXCVA lead wire/coupler	
P1657				
P1657		H	EXCVA position sensor voltage is higher than specified value.	EXCVA position sensor circuit shorted to VCC or ground circuit open
		L	EXCVA position sensor voltage is lower than specified value.	EXCVA position sensor circuit open or shorted to ground or VCC circuit open
P1658		When no actuator control signal is supplied from the ECM, communication signal does not reach ECM or operation voltage does not reach EXCVA motor, C46 (P1658) is indicated. EXCVA motor can not operate.	EXCVA, EXCVA motor lead wire/coupler	
C49/C61	PAIR control solenoid valve	PAIR control solenoid valve voltage is not input to ECM.	PAIR control solenoid valve, lead wire/coupler	
P1768/P1656				
C60	Cooling fan relay	Cooling fan relay signal is not input to ECM.	Cooling fan relay, lead wire/coupler connection	
P0480				



# “C44” (P0156) or “C64” (P0130) O2 SENSOR (O2S) CIRCUIT MALFUNCTION (FOR E-02, 19, 24, 51)

DETECTED CONDITION		POSSIBLE CAUSE
C44/C64 (P0156/ P0130)	O2 sensor output voltage is not input to ECM during engine operation and running condition. (Sensor voltage < 0.45 V)	<ul style="list-style-type: none"> <li>• O2 sensor circuit open or shorted to ground.</li> <li>• Fuel system malfunction.</li> <li>• ECM malfunction.</li> </ul>

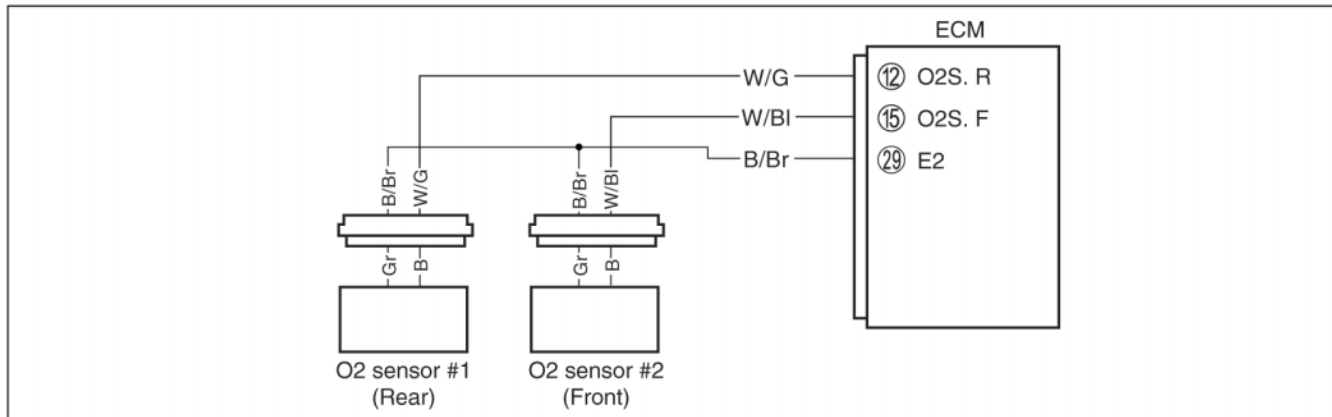

## INSPECTION

### Step 1

(When indicating C44/P0156 for O2 sensor #2)

(When indicating C64/P0130 for O2 sensor #1)

- 1) Turn the ignition switch OFF.
- 2) Check the O2 sensor for loose or poor contacts.  
If OK, then check the O2 sensor lead wire continuity.

- 3) Disconnect the O2 sensor coupler.
- 4) Check the continuity between W/G (#1) or W/Bl (#2) wire (A) and ground.
- 5) Also, check the continuity between W/G (#1) or W/Bl (#2) wire (A) and B/Br wire (B). If the sound is not heard from the tester, the circuit condition is OK.

 **09900-25008: Multi-circuit tester set**

 **Tester knob indication: Continuity test (•))**

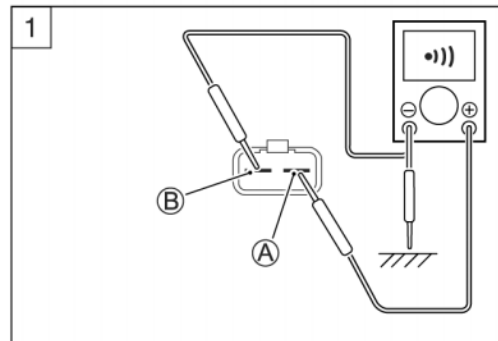
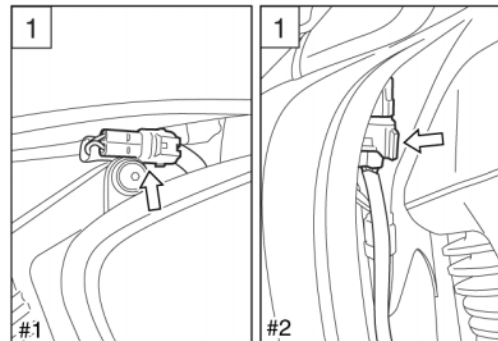

- 6) Disconnect the ECM coupler. (☞ 5-37)
- 7) Check the continuity between W/G or W/BI wire (A) and terminal (12), (15).
- 8) Also, check the continuity between B/Br wire (B) and terminal (29).

**CAUTION**

When using the multi-circuit tester, do not strongly touch the terminal of the ECM coupler with a needle pointed tester probe to prevent terminal damage or terminal bend.

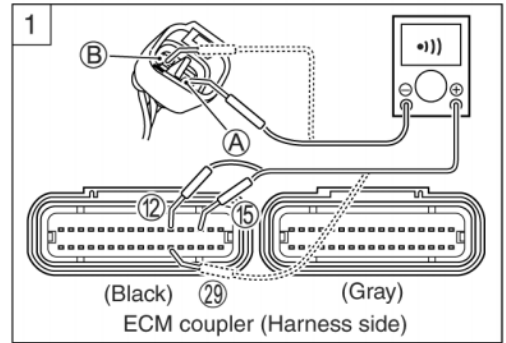

**DATA** O2S lead wire continuity: Continuity (••))

**TOOL** 09900-25008: Multi-circuit tester set  
09900-25009: Needle pointed probe set

**Tester knob indication: Continuity test (••))**

Is the continuity OK?

YES	Go to Step 2. (When indicating C44/P0130:)
NO	W/G or W/BI wire shorted to ground, or W/G and W/BI or B/Br wire open.

- 9) After repairing the trouble, clear the DTC using SDS tool. (☞ 5-26)

**Step 2**

- 1) Connect the ECM coupler and O2 sensor coupler.
- 2) Warm up the engine enough.
- 3) Measure the O2 sensor output voltage between W/G or W/BI wire and B/Br wire, when idling condition.

**DATA** O2 sensor output voltage at idle speed:  
0.4 V and less (+ W/G or W/BI – – B/Br)

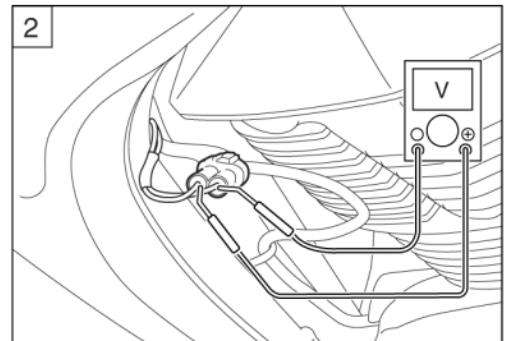

- 4) If OK, then pinch the PAIR hose (1) with a proper hose clamp.
- 5) Remove the fuel tank (☞ 6-3) and frame head covers (☞ 9-6).
- 6) Measure the O2 sensor output voltage while holding the engine speed at 3 000 r/min.

**DATA** O2 sensor output voltage at 3 000 r/min:  
0.6 V and more (+ W/G or W/BI – – B/Br)

**TOOL** 09900-25008: Multi-circuit tester set  
09900-25009: Needle pointed probe set

**Tester knob indication: Voltage (---)**

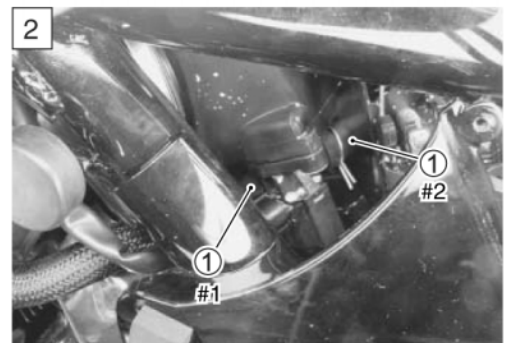

Is the voltage OK?

YES	<ul style="list-style-type: none"><li>• W/G wire or B/Br wire open or shorted to ground, or poor ⑫, ⑮ or ⑲ connection.</li><li>• If wire and connection are OK, intermittent trouble or faulty ECM.</li><li>• Recheck each terminal and wire harness for open circuit and poor connection.</li><li>• Replace the ECM with a known good one, and inspect it again.</li></ul>
NO	Replace the O2 sensor with a new one.

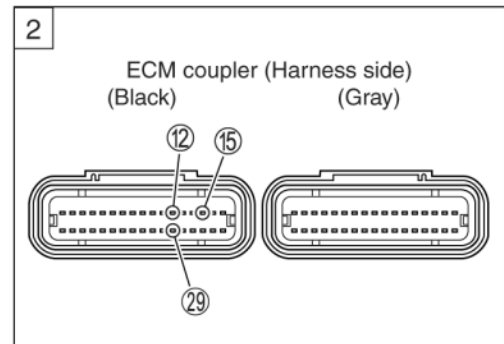

7) After repairing the trouble, clear the DTC using SDS tool.  
( 5-26)

# “C49” (P1768) or “C61” (P1656) PAIR CONTROL SOLENOID VALVE CIRCUIT MALFUNCTION

DETECTED CONDITION	POSSIBLE CAUSE
PAIR control solenoid valve voltage is not input to ECM.	<ul style="list-style-type: none"> <li>• PAIR control solenoid valve circuit open or short</li> <li>• PAIR control solenoid valve malfunction</li> <li>• ECM malfunction</li> </ul>

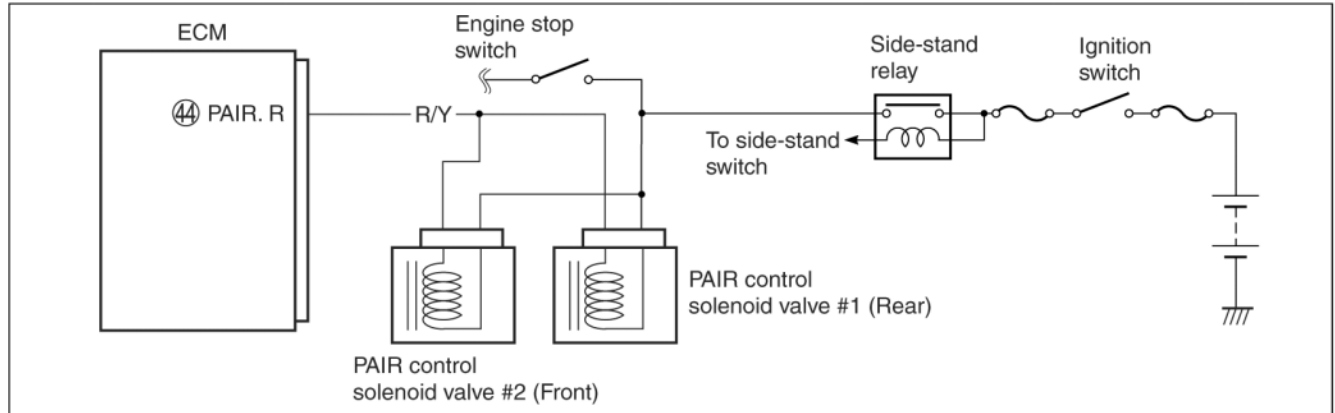

## Step 2

- 1) Turn the ignition switch ON.
- 2) Measure the voltage between O/B wire and ground.

**DATA PAIR valve voltage: Battery voltage**  
(+ O/B – - Ground)

**TOOL 09900-25008: Multi-circuit tester set**

**Tester knob indication: Voltage (---)**



Is the voltage OK?

YES	<ul style="list-style-type: none"> <li>• R/Y wire open or shorted to ground, or poor ④④ connection failure.</li> <li>• If wire and connection are OK, intermittent trouble or faulty ECM.</li> <li>• Recheck each terminal and wire harness for open circuit and poor connection.</li> <li>• Replace the ECM with a known good one, and inspect it again.</li> </ul>
NO	Open or short circuit in the O/W wire.

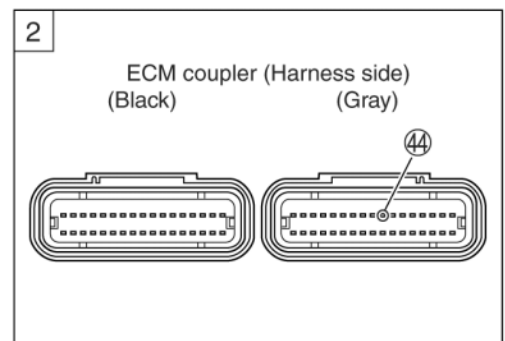

- 3) After repairing the trouble, clear the DTC using SDS tool.  
(5-26)

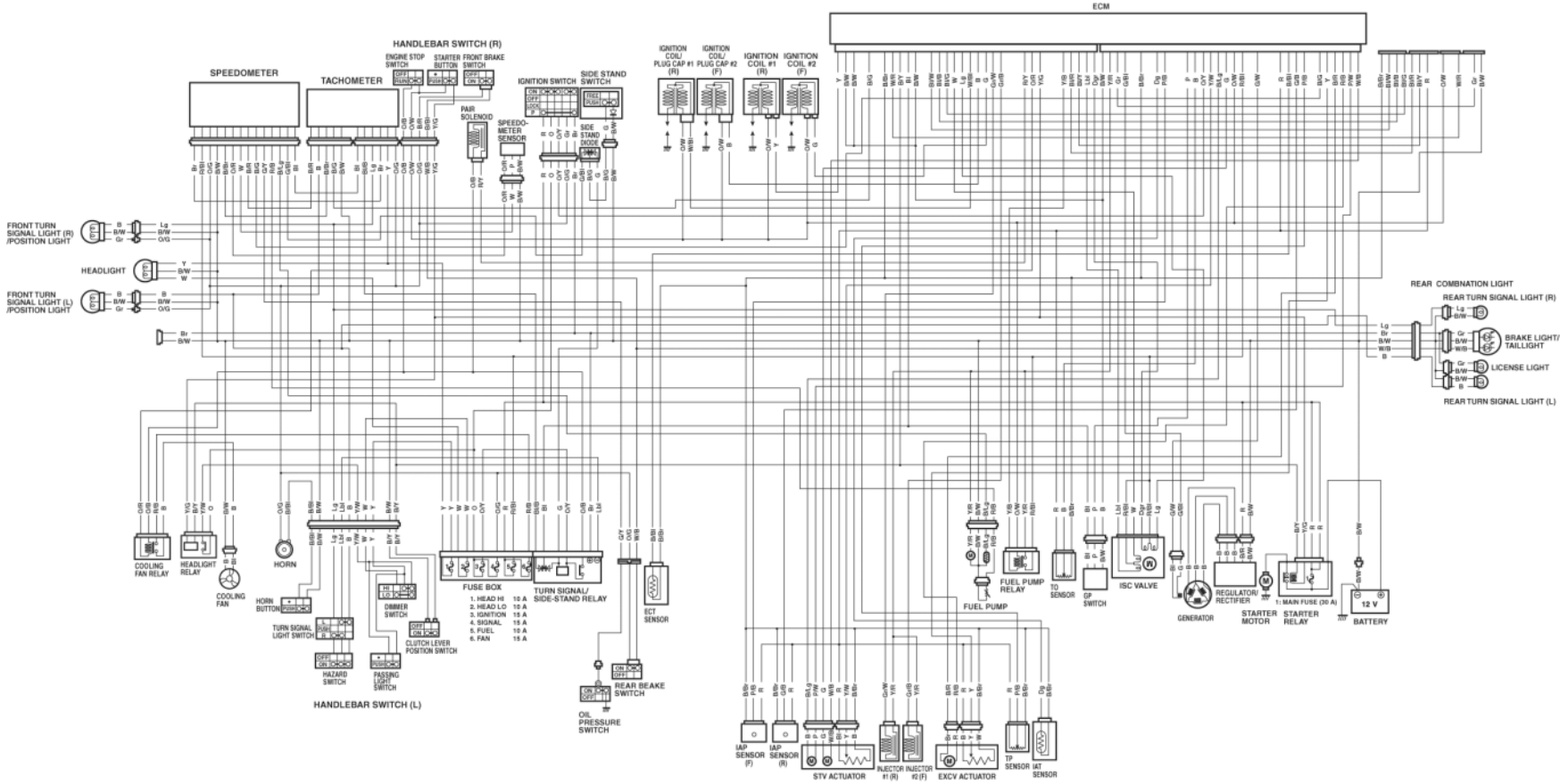

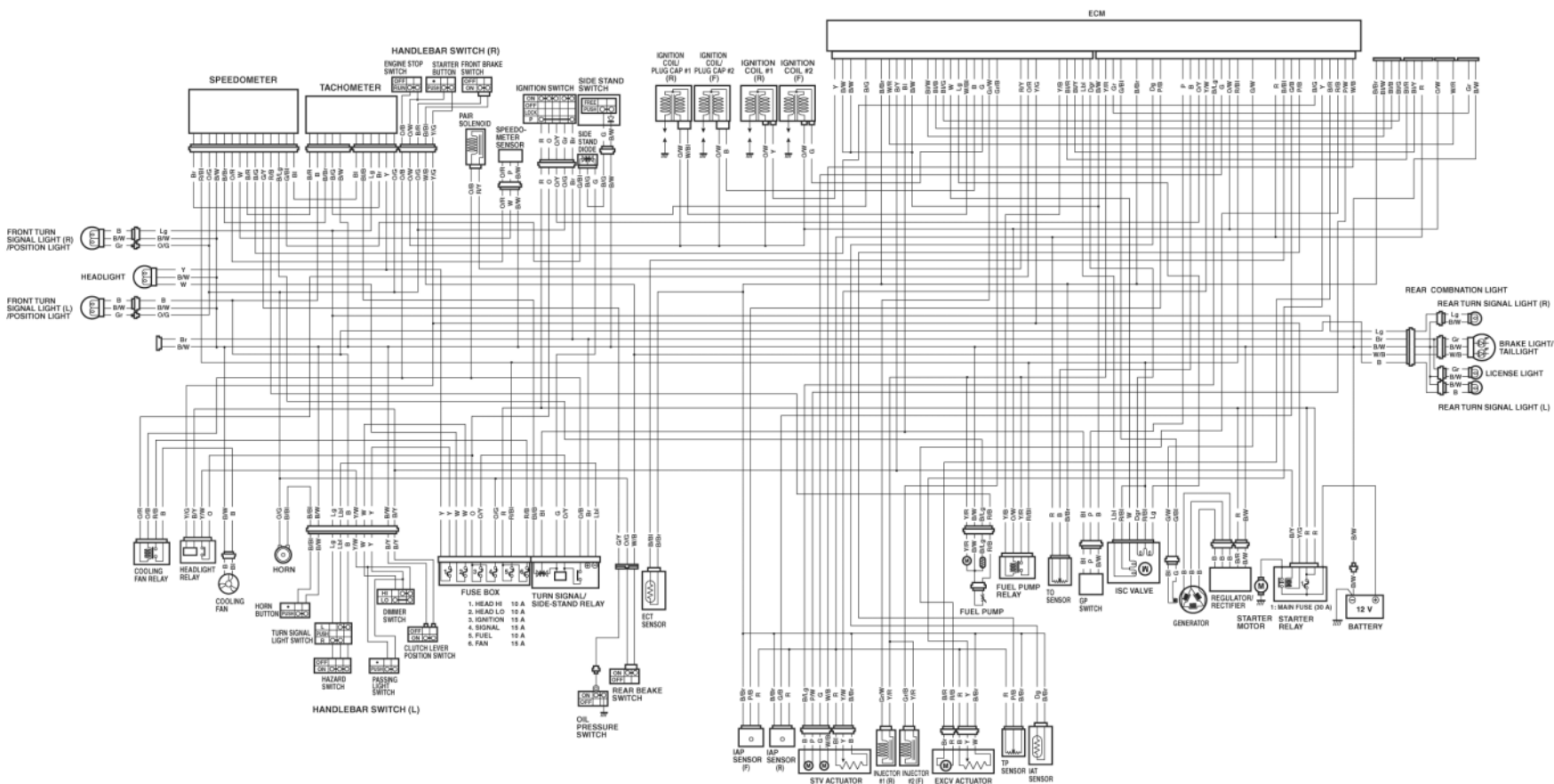

# CABLE ROUTING

Pass the throttle cables between the handlebars and brake hose.

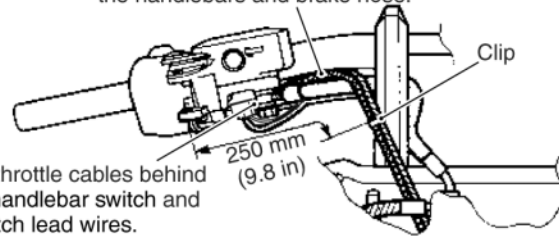

Pass the throttle cables behind the right handlebar switch and brake switch lead wires.

**VIEW A**

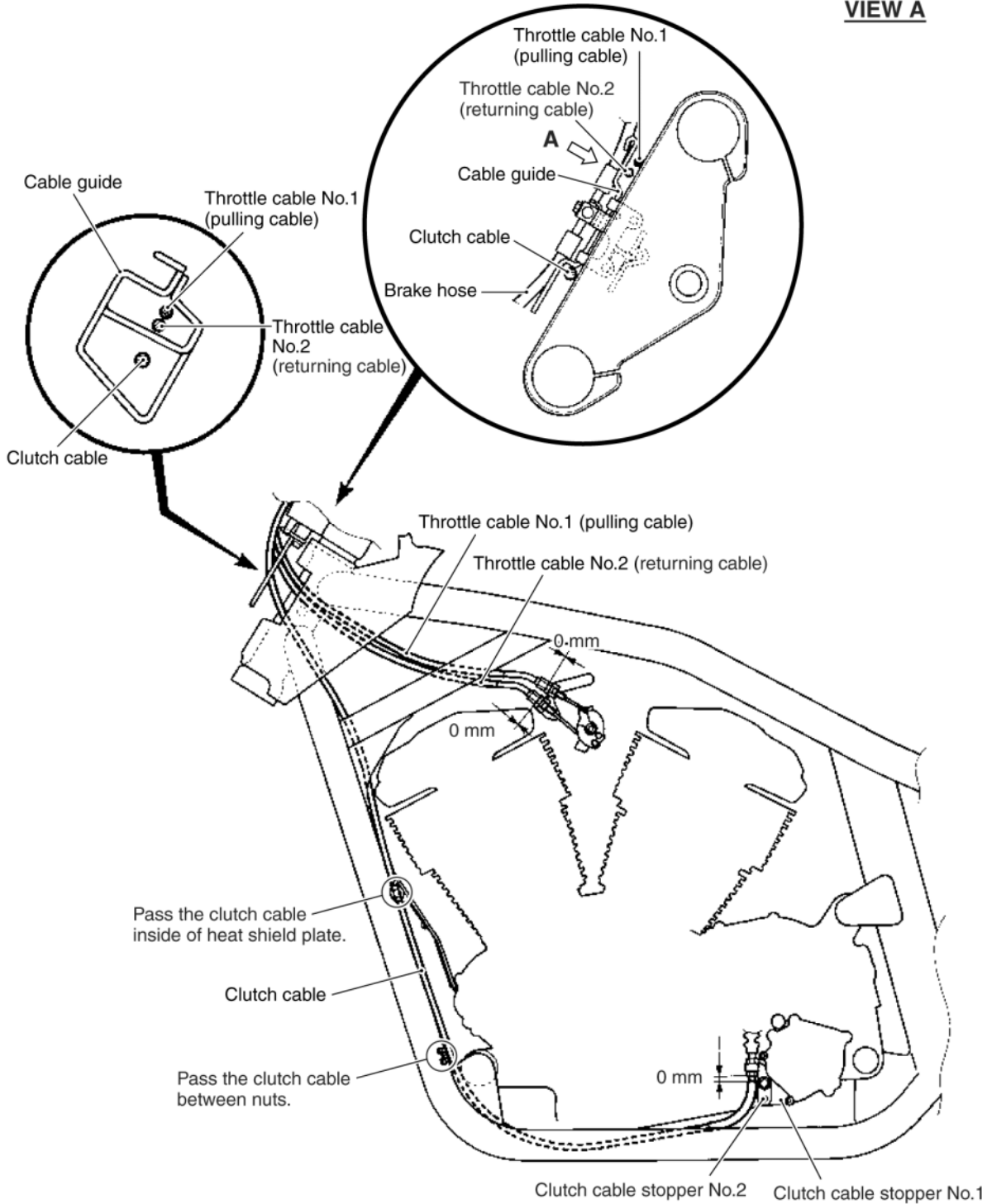



# REAR WHEEL CONSTRUCTION

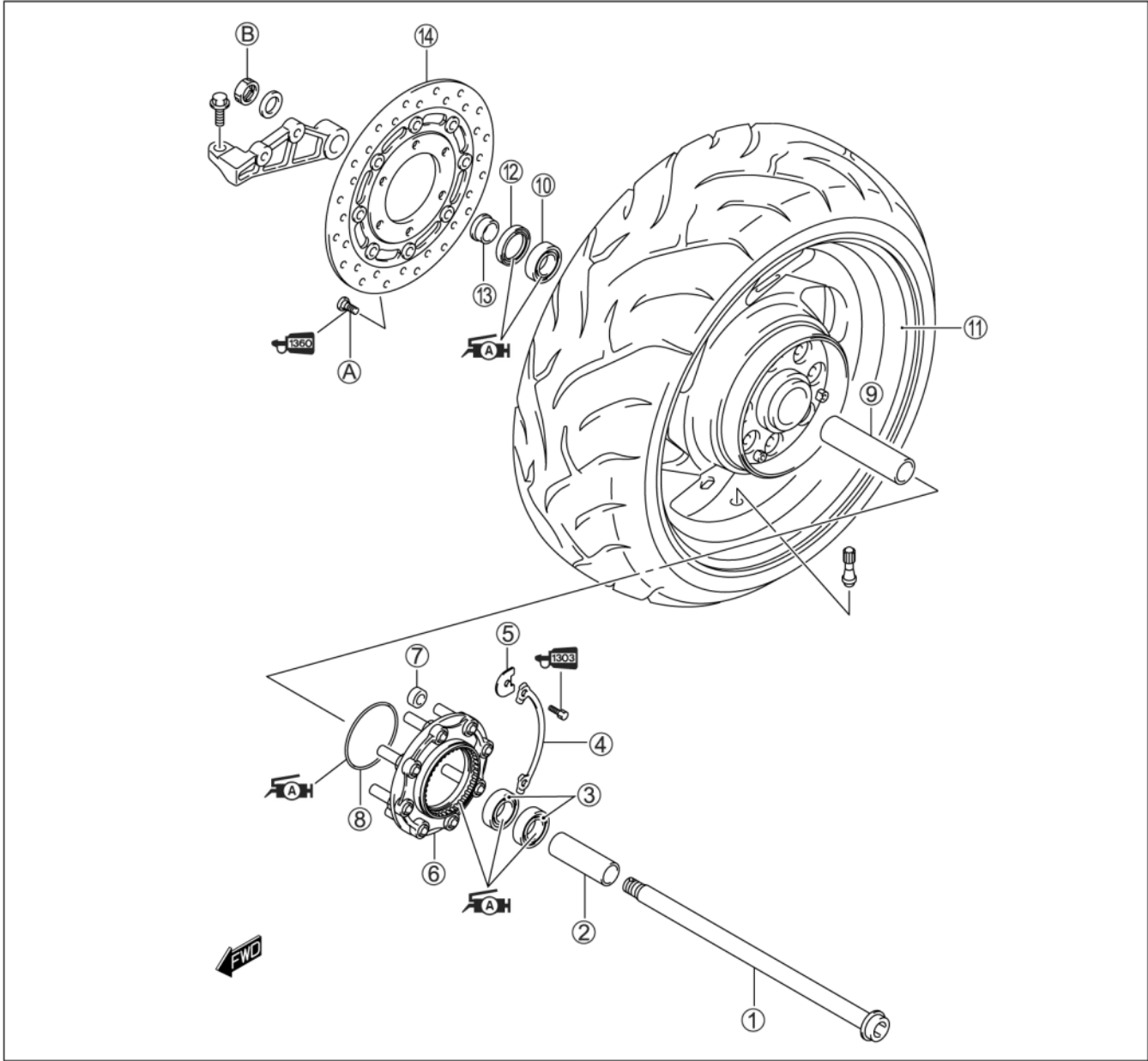

①	Rear axle	⑦	Damper	⑬	Collar
②	Spacer	⑧	O-ring	⑭	Brake disc
③	Bearing	⑨	Spacer	Ⓐ	Rear brake disc bolt
④	Lock washer	⑩	Bearing	Ⓑ	Rear axle nut
⑤	Driven joint stopper	⑪	Rear wheel		
⑥	Driven joint	⑫	Dust seal		



ITEM	N·m	kgf·m	lb·ft
Ⓐ	23	2.3	16.5
Ⓑ	110	11.0	79.5

# HEADLIGHT BEAM ADJUSTMENT

The headlight beam can be adjusted both horizontally and vertically if necessary.

- Remove the right and left fasteners.

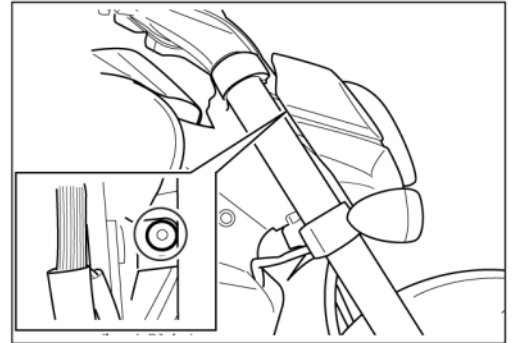

- Pull the lower part of the headlight upper cover forward ① to unhook the lower hooks. Then pull the upper part of the cover upward to unhook the upper hook.

## NOTE:

*Stick protection tape on the headlight lens to avoid scratching.*

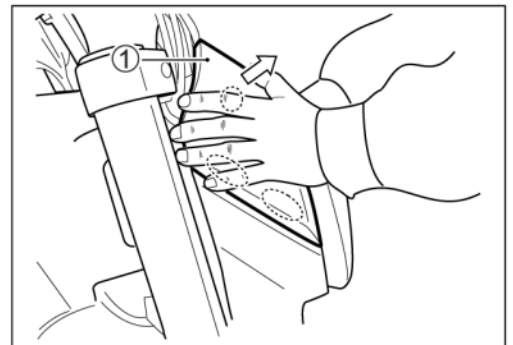

## To adjust the beam horizontally

Turn the screw ① located on the left side of the headlight unit clockwise or counterclockwise.

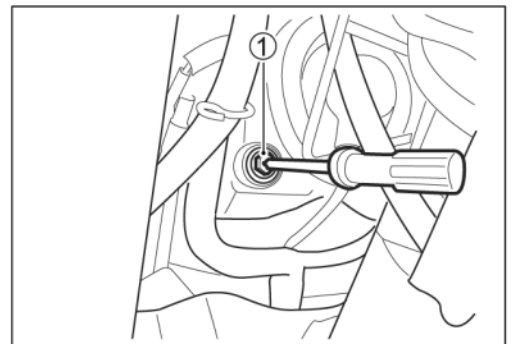

## To adjust the beam vertically

Turn the screw ② located on the right side of the headlight unit clockwise or counterclockwise.

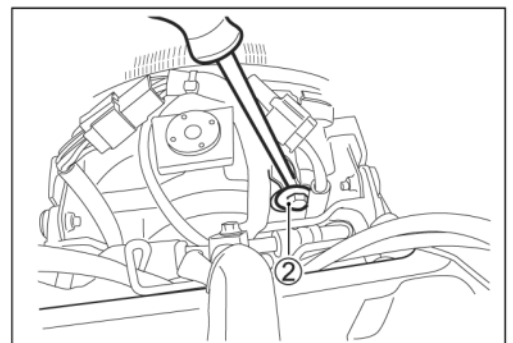

Install the headlight upper cover in the reverse order of removal.

# WIRING DIAGRAM

E-02, 19, 24

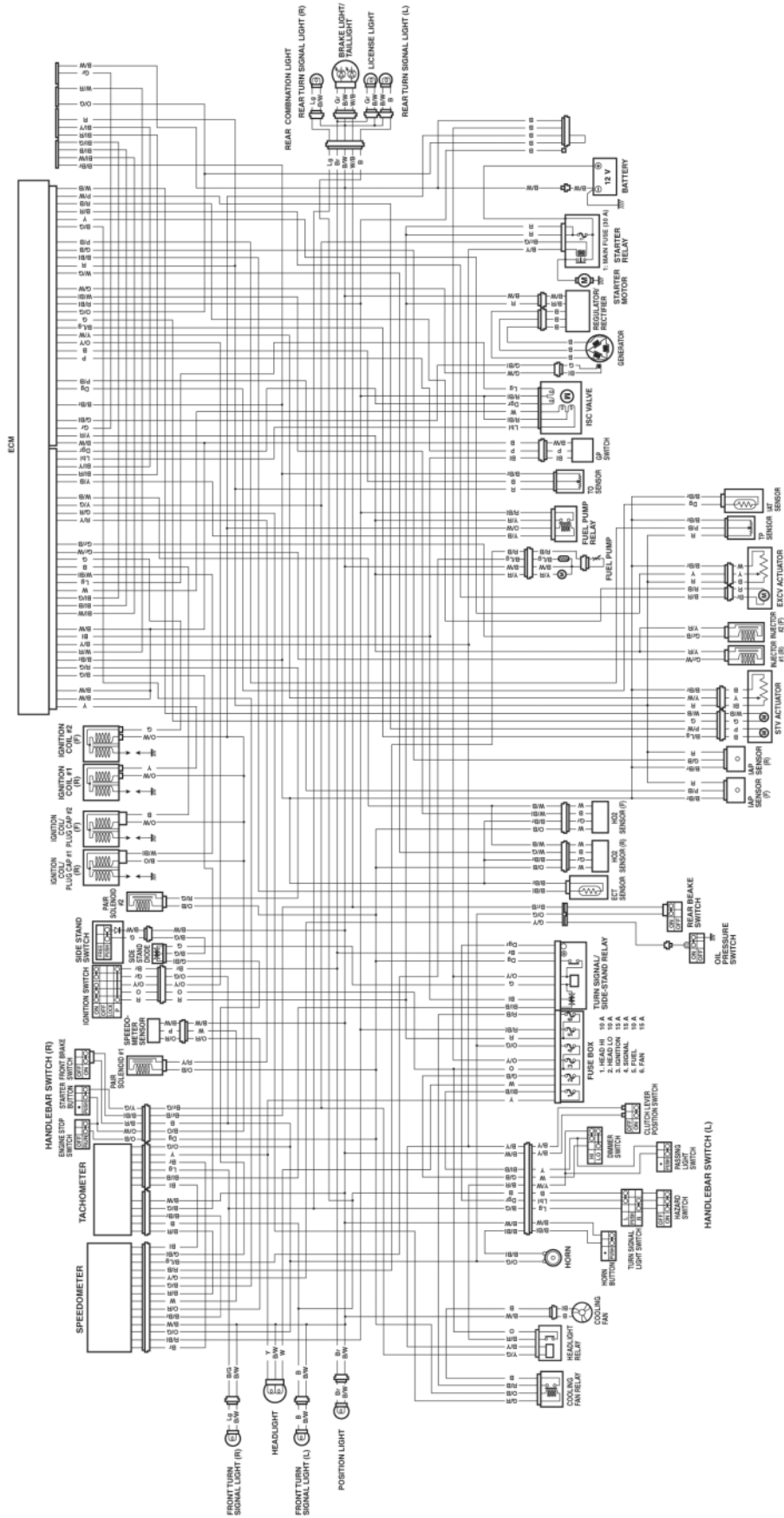

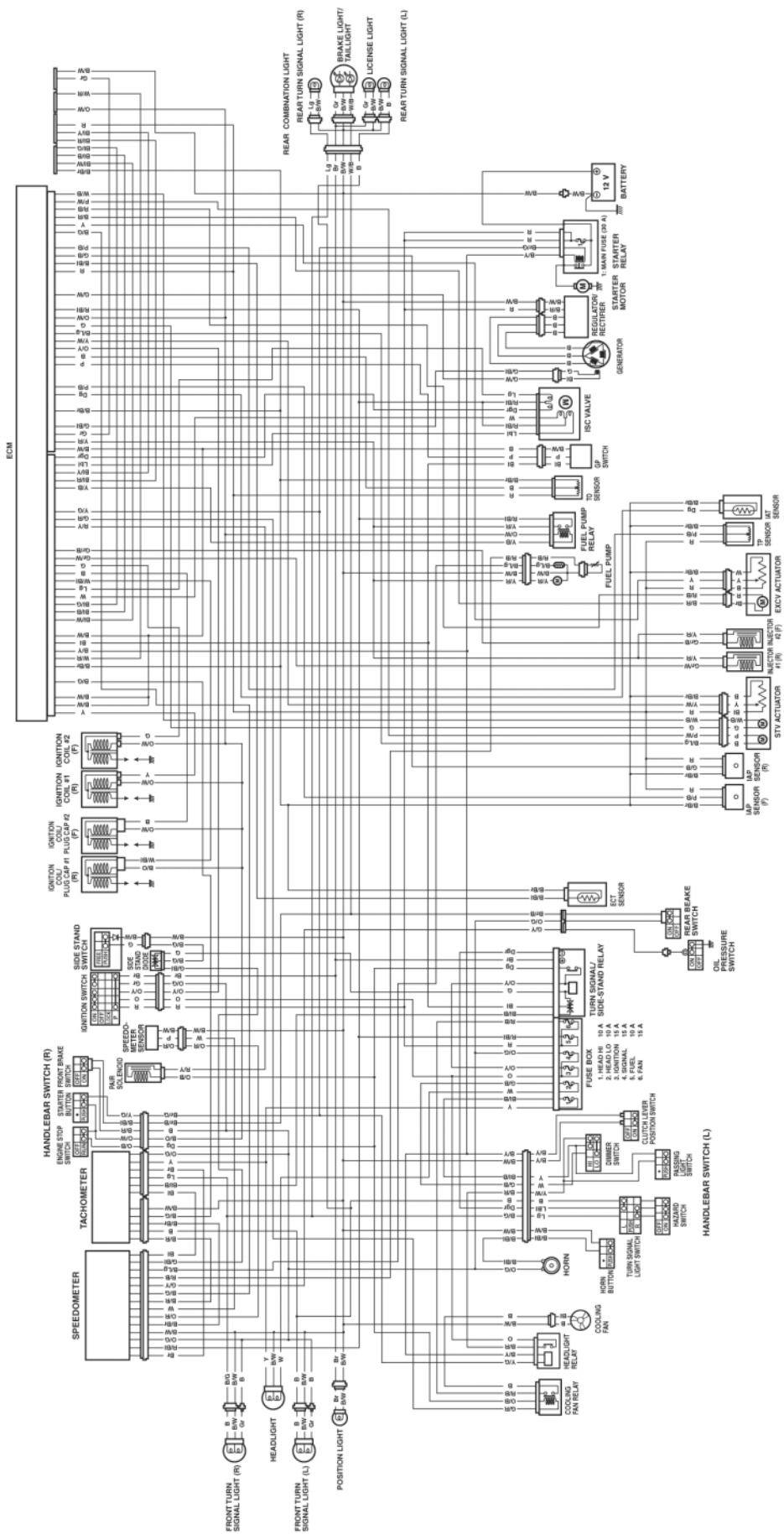

# WIRING HARNESS ROUTING

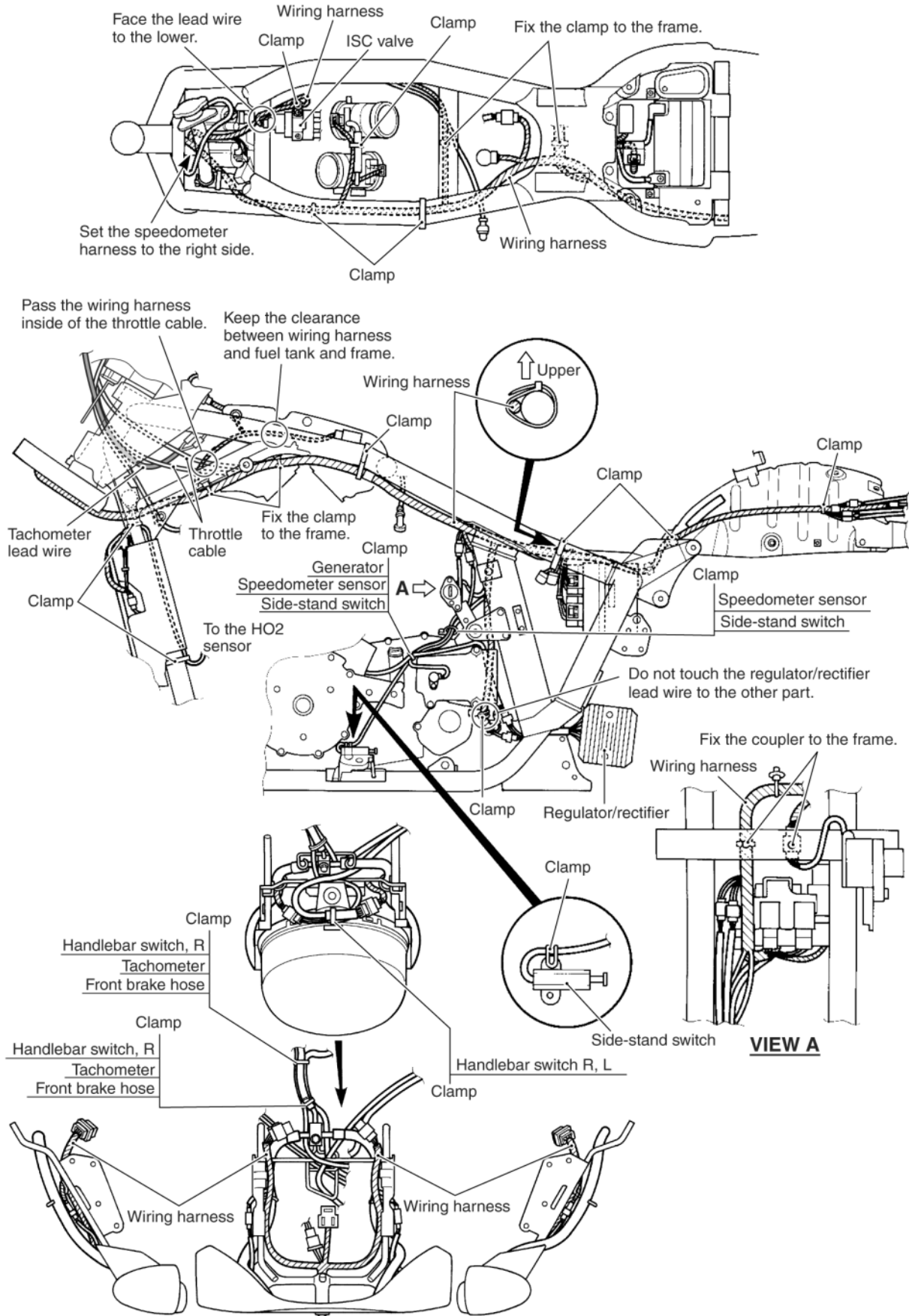

Pass the handlebar switch lead wire  
upper the brake switch coupler.

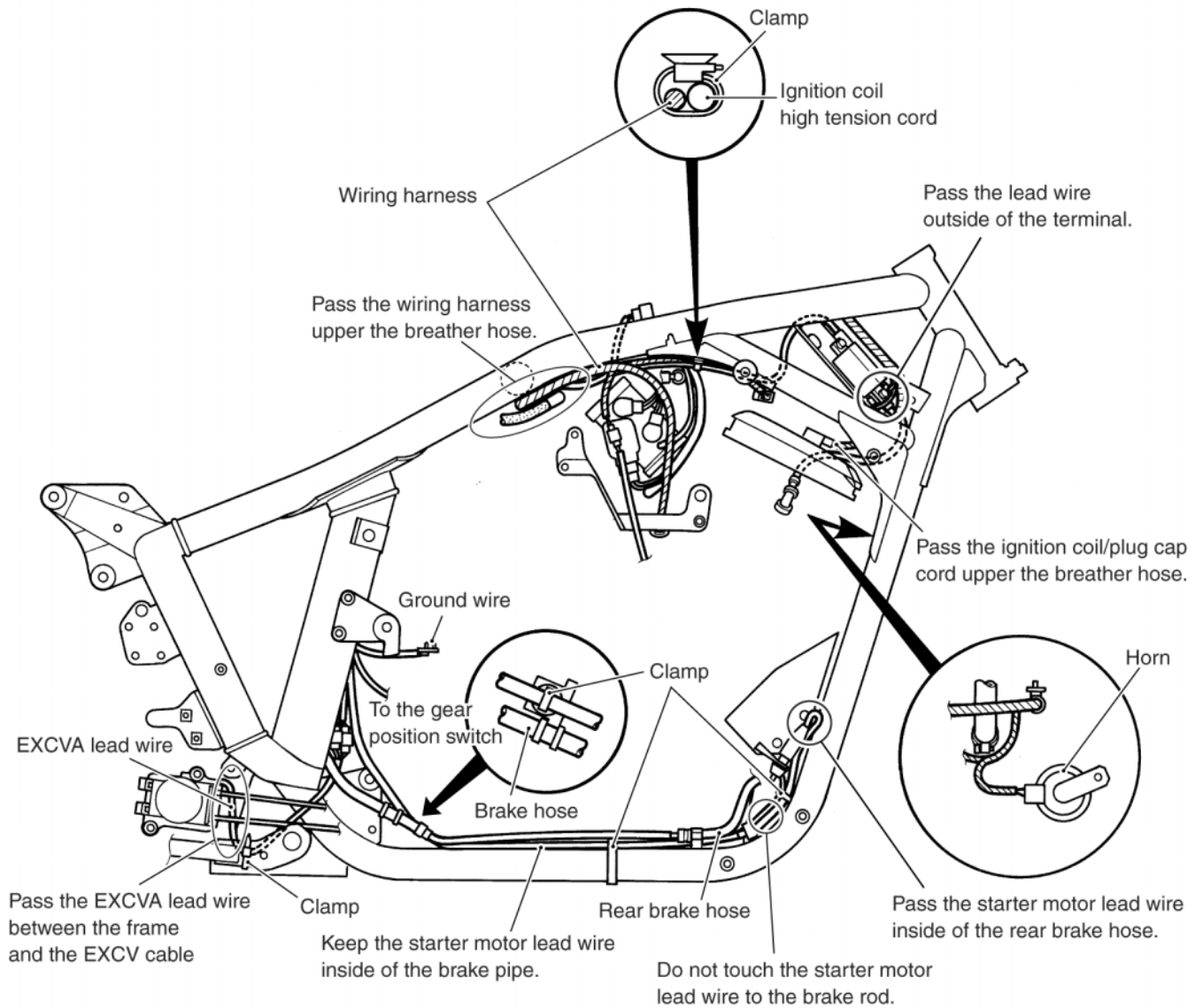
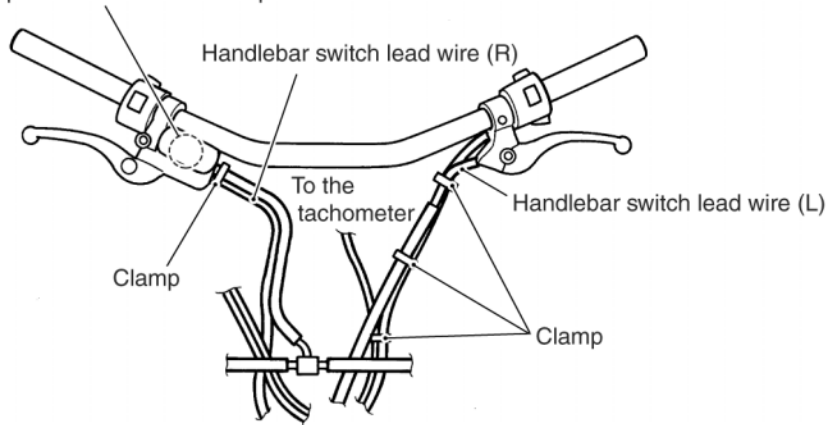

# FRONT BRAKE HOSE ROUTING

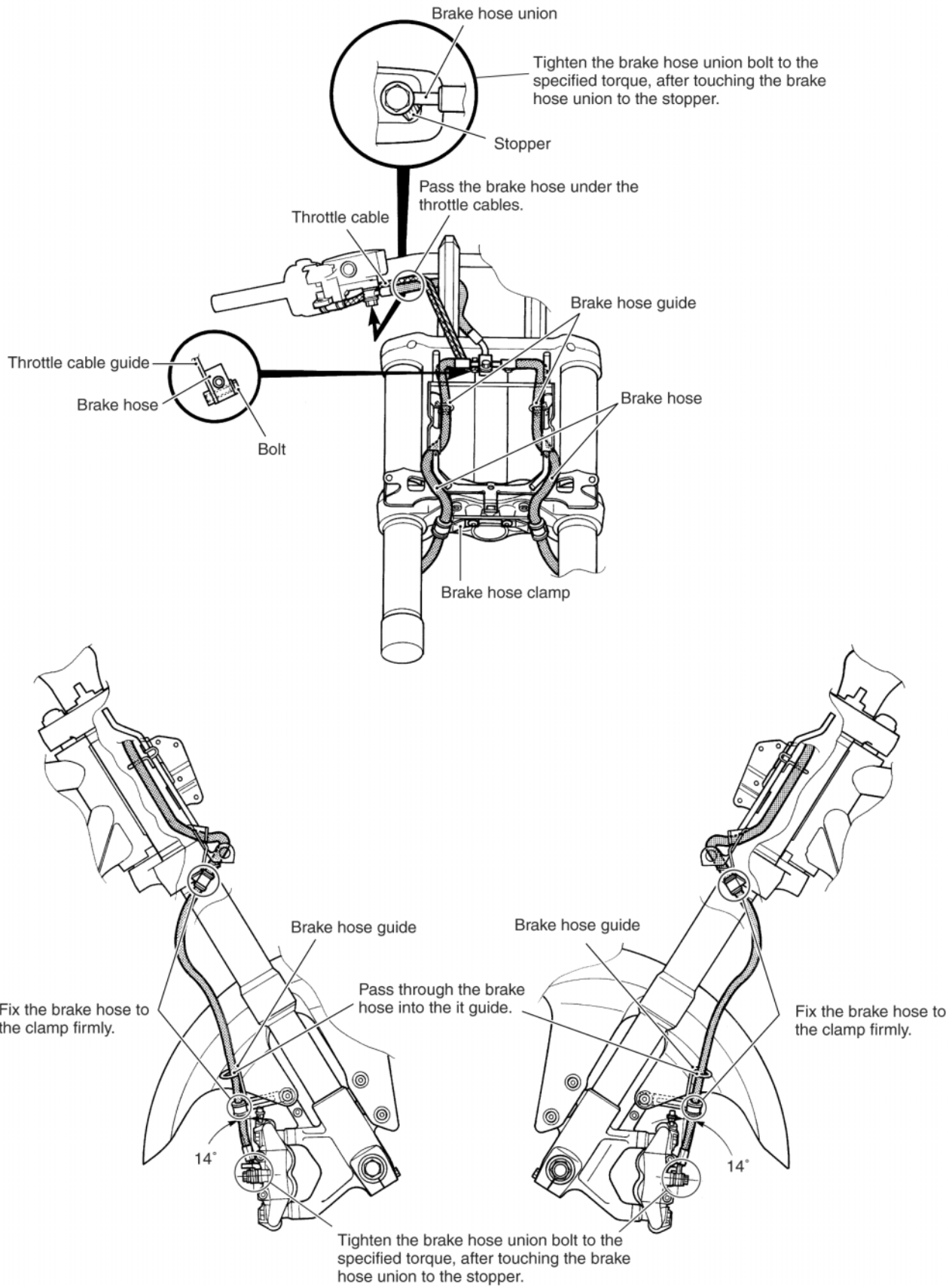





# Service Bulletin

MOTORCYCLE/ATV DIVISION

4-STROKE  
BULLETIN NO. VS/VX/VZ/VL NO. 51  
DATE: 4/3/2007

**SAFETY RECALL CAMPAIGN  
VZR1800K6 & VZR1800/ZK7 (M109R)  
FUEL DELIVERY PIPE REPLACEMENT  
CAMPAIGN #2096**

**SUBJECT:** RECALL CAMPAIGN - FUEL DELIVERY PIPE REPLACEMENT  
**AFFECTED UNITS:** ALL 2006 AND CERTAIN 2007 MODEL YEAR VZR1800s  
**REFERENCE:** VZR1800 SERVICE MANUAL (P/N 99500-39291-03E)  
**ATTACHMENTS:** CUSTOMER LETTER

**NOTICE:**

This notice is sent to you in accordance with the requirements of the National Traffic and Motor Vehicle Safety Act. Suzuki Motor Corporation has decided that a defect which relates to motor vehicle safety exists in all 2006 and certain 2007 model year VZR1800/Z motorcycles. Suzuki Motor Corporation is conducting a voluntary Safety Recall Campaign.

***STOP DELIVERY OF ALL 2006 AND CERTAIN 2007 VZR1800/Z MOTORCYCLES***

**DO NOT DELIVER** an affected VZR1800/Z to a customer until you have completed, or verified completion of, the repair procedures outlined in this bulletin.

Federal law requires that **ALL** vehicles affected by a safety recall campaign be corrected prior to sale or lease to a customer. You must verify this on the Suzuki "Certificate of Vehicle Pre-Delivery" form (99923-09823-005), which is to be completed for all new and used vehicle sales.

**WHAT IS THE PROBLEM?**

Suzuki Motor Corporation has determined that on some affected motorcycles, the fuel hose that connects the two metal fuel delivery pipes mounted on the throttle body may have been clamped at a location on the pipes that is not completely round, which could allow fuel leakage to occur. In the presence of an ignition source, leaked fuel can cause a fire, presenting the risk of injury or death.

**AFFECTED UNIT VIN RANGES:** (\* indicates the check digit)

**VZR1800K6: JS1VY53A\*62100050 ~ JS1VY53A\*62106130**  
**VZR1800/ZK7: JS1VY53A\*72100009 ~ JS1VY53A\*72107567**

**VERIFY THE UNIT REQUIRES MODIFICATION:**

Before performing the recall repair to a unit, first verify that the repair needs to be performed using one of the following methods; 1) Check the repair status by checking the Vehicle History in the Suzuki Connect Service Menu. If the repair needs to be performed, you will see the message "CAMPAIGN NOT YET PERFORMED" displayed and the fuel delivery pipe assembly will need to be replaced. Or 2) Inspect the unit for a punch mark located before the VIN ① as indicated below. A punch mark indicates the recall repair has already been completed.



**WHAT YOUR DEALERSHIP WILL DO:**

Your dealership will replace the fuel delivery pipe assembly. Suzuki requests that you replace the fuel delivery pipe assembly on any affected units in your inventory as soon as possible, including units still in crates.

**WHAT SUZUKI WILL DO:**

On Friday April 6, 2007 Suzuki will mail notification letters to the owners of affected motorcycles for whom we have information. The letter asks the customer to contact the dealer where they purchased their motorcycle to schedule an appointment (see attachment).

**ORDERING PARTS FOR THE RECALL CAMPAIGN:**

Parts for the Recall Campaign will **NOT** be auto-shipped to your dealership. Using your normal parts ordering method, refer to the part number below to order parts for an affected unit, even if your dealership did not originally sell the unit. **Parts are currently available. Order parts only on an as-needed basis.**

**Fuel Delivery Pipe Assembly Kit      Part# 99103-11225      Dealer Net: \$105.77**

*NOTE: The replacement fuel delivery pipe assembly has a blue paint mark as shown.*

**Kit Contents**

Part No.	Part Name	Qty
15730-48G01	Pipe Assy, Delivery	1
15717-16G00	O-ring	2
15722-29G00	Seal	2
13602-06148	Screw	4
09407-14407	Clamp, wiring harness	1
	Retainer, fuel hose connector	1

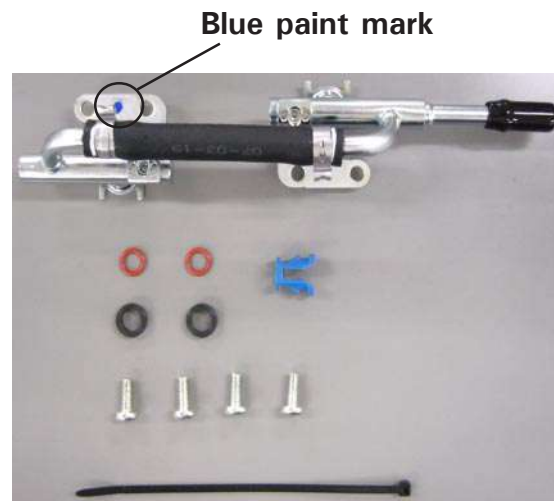

**WARRANTY CLAIM PROCESSING:**

Submit a warranty claim for each recall campaign service immediately upon completion of the repair. This campaign requires you to file a warranty claim using the method described below.

**Short Form Claim:**

Labor time is 1.0 hours

<b>RECALL CAMPAIGN - FUEL DELIVERY PIPE ASSY. REPLACEMENT</b>	
<b>Short Form Instructions</b>	
<b>GENERAL</b>	
CLAIM NUMBER:	XXXXX,X (Dealer enters number)
ENTRY TYPE: (Dealer Chooses)	Model, Frame or Control Sequence
MODEL:	VZR1800K6 or VZR1800K7
FRAME:	X6XXXXXXXX or X7XXXXXXXX
REPAIR DATE:	Enter date of repair
MILEAGE:	Enter mileage on unit
CAMPAIGN NUMBER:	2096

**Long Form Claim:**

Labor time is 1.0 hours

<b>RECALL CAMPAIGN - FUEL DELIVERY PIPE ASSY. REPLACEMENT</b>	
<b>Long Form Instructions</b>	
<i>Claim Type for unit with ADDITIONAL time or parts required</i>	
<b>GENERAL</b>	
CLAIM NUMBER:	XXXXX,X (Dealer enters number)
ENTRY TYPE: (Dealer Chooses)	Model, Frame or Control Sequence
MODEL:	VZR1800K6 or VZR1800K7
FRAME:	X6XXXXXXXX or X7XXXXXXXX
REPAIR DATE:	Enter date of repair
MILEAGE:	Enter mileage on unit
CAMPAIGN NUMBER:	2096
LABOR HOURS:	1.0 hrs
SUZUKI AUTH. NUMBER:	As approved by TECH-LINE
<b>PARTS</b>	
REPLACEMENT PART NUMBER:	NO PARTS REQUIRED
<b>FAILURE DESCRIPTION</b>	
DESCRIPTION OF FAILURE:	Replace Fuel Delivery Pipe Assy per Service Bulletin VS/VX/VZ/VL #51
<b>SUBLET</b>	
SUBLET AMOUNT:	as approved by TECH-LINE
<i>NOTE: Do not use the "\$" when entering an amount</i>	
SUBLET REFERENCE NUMBER:	2096
SUBLET REPAIR DESCRIPTION:	

## FUEL DELIVERY PIPE ASSEMBLY REPLACEMENT PROCEDURE

### **⚠ WARNING**

**When working with the fuel system, work in a well ventilated area away from any flame or ignition sources. Store the motorcycle in an area away from any flame or ignition sources.**

NOTE: The fuel delivery pipe assembly can be removed from the throttle body without removing the throttle body assembly from the motorcycle.

- 1) Refer to section 6 of the service manual to remove the fuel tank and the air cleaner box. *Place shop rags over the bore of each throttle body to prevent anything from falling into the engine through the throttle bodies.*
- 2) Remove the wire harness clamp, disconnect the fuel injector couplers (A) and move the harness aside.
- 3) Remove the four fuel delivery pipe assembly mounting screws and remove the fuel delivery pipe assembly.
- 4) Replace the o-rings and seals with the new parts supplied in the kit (apply a small amount of engine oil to the o-rings and seals to ease the installation of the injector).

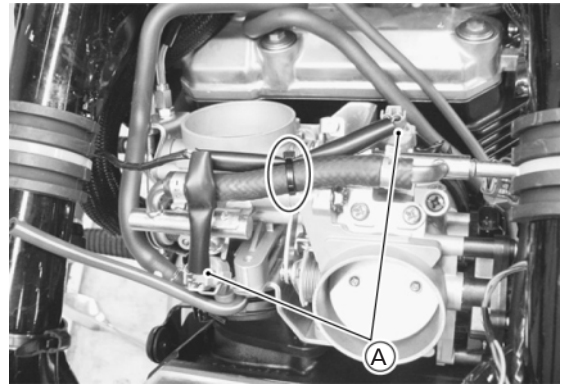

### **CAUTION**

**To prevent damage to the o-rings or seals, don't turn the injector when pushing it into the fuel delivery pipe and throttle body respectively.**

Install the new fuel delivery pipe assembly in the reverse order of removal.

**🔧 Fuel Delivery Pipe Mounting Screw Torque: 5 N.m (0.5 kgf.m, 3.5 lb-ft)**

- 5) Connect the fuel injector couplers (A) and clamp the injector harness to the fuel delivery pipe.

### **CAUTION**

**DO NOT overtighten the harness clamp.**

- 6) Connect the fuel tank, remove the shop rags from over the bore of each throttle body, and run the engine, checking for fuel leaks.

### **CAUTION**

**DO NOT reuse the original fuel hose connector retainer. Confirm that the fuel hose connector has completely seated and locked (clicked) into position before turning on the ignition switch.**

- 7) Refer to section 6 of the service manual to install the air cleaner box and the fuel tank.
- 8) Test ride the motorcycle to confirm proper operation.

## FUEL DELIVERY PIPE ASSEMBLY REPLACEMENT PROCEDURE cont.

- 9) Place a punch mark near the beginning on the VIN as indicated to confirm that the recall repair has been completed and file a warranty claim.



### DEFECTIVE PARTS RETENTION:

Tag the replaced parts with a warranty parts tag and hold them for 120 days. If an ASMC representative has not asked your dealership to return the parts within the 120 day period, you may dispose of them in a suitable manner.

### IMPORTANT:

Successful completion of this safety recall campaign depends on your efforts. It is your responsibility to repair any affected VZR1800 within the VIN range at no cost to the customer for recall service parts and labor. Incidental costs your customers may incur are not normally covered. However, if you have a customer with special needs, contact your Technical Service Manager (800/756-3251) to discuss possible solutions.

### CUSTOMER SATISFACTION:

We understand and apologize for any inconvenience this recall campaign may cause you or your customers.

Thank you for your cooperation in conducting this very important campaign for your customers' safety and satisfaction.

Only your conscientious action at the dealership level can lead to a successful campaign conclusion. Please extend Suzuki's apologies for any inconvenience this recall campaign may cause them.

Refer to page 7 for detailed information regarding Customer Reimbursement.

### AFFECTED DEPARTMENTS:

The following departments in your dealership should be notified of this information:

Management    Service    Warranty    Sales    Parts    Accessories

American Suzuki Motor Corporation  
Technical Service Department  
Motorcycle / ATV



April 6, 2007

Dear Suzuki Owner,

This notice is sent to you in accordance with the requirements of the National Traffic and Motor Vehicle Safety Act.

**What is the reason for this notice?**

Suzuki Motor Corporation has decided that a defect that relates to motor vehicle safety exists in all 2006 and certain 2007 model year VZR1800/Z (M109R) motorcycles. According to our records, you are the owner of one of these affected VZR1800 (M109R) motorcycles.

**What is the problem?**

Suzuki Motor Corporation has determined that on some affected motorcycles, the fuel hose that connects the two metal fuel delivery pipes mounted on the throttle body may have been clamped at a location on the pipes that is not completely round, which could allow fuel leakage to occur. In the presence of an ignition source, leaked fuel can cause a fire, presenting the risk of injury or death.

**▲ WARNING**

**DO NOT OPERATE YOUR AFFECTED  
2006 or 2007 VZR1800/Z (M109R) MOTORCYCLE**

To minimize the risk of injury or death, do not ride, or allow anyone else to ride, your VZR1800/Z (M109R) motorcycle until this recall repair has been completed. We also recommend that you store your motorcycle in a well ventilated area away from any source of ignition (e.g. gas water heater, gas dryer etc.) until the recall repair has been completed.

**What is Suzuki doing to solve the problem?**

Your dealer will replace the fuel delivery pipe assembly. Repair time is approximately 1 hour and will be done at no cost to you for parts or labor.

**How do I receive the fastest possible service?**

Suzuki understands that your riding time is precious. Our suggestion is to work closely with your authorized Suzuki dealer to get your motorcycle's recall service scheduled and performed as quickly as possible. Schedule an appointment for the recall service to be performed.

Parts are currently available but it will be necessary for your dealer to order the parts. It may be necessary to leave your motorcycle with the dealer overnight, so check with your dealer. When you pick up your repaired motorcycle, please allow a few extra minutes for your dealer to prepare and complete the necessary warranty paperwork with you.

If you have special circumstances, discuss them with your Suzuki dealer. Suzuki understands that some customers may have difficult circumstances to overcome in bringing their motorcycle to the dealership for repair. We have asked your Suzuki dealer to work closely and flexibly with you to arrange alternative, but reasonable solutions for your special requests. Please remember, however, that each dealership has its own limitations in providing special assistance due to staff size, available time, and dealership location. Your dealer can also consult with Suzuki on other alternatives.



## CUSTOMER NOTIFICATION LETTER - Page Two of Two

### Questions & Answers

Your Suzuki dealer has been provided specific and complete instructions regarding this recall service. Please call your dealer if you have any questions. Your local Suzuki dealer can provide the fastest responses to your questions or concerns about the recall service. Your dealer can also contact Suzuki on your behalf if you have a unique question or concern.

If you have difficulty having the recall service performed on your motorcycle you may contact the American Suzuki Customer Service Department for assistance at 714-572-1490. You will need to have your Vehicle Identification Number ready when calling.

If you believe that (1) Suzuki or your Suzuki dealer has failed to or is unable to perform the recall service without charge, or (2) Suzuki has failed to or is unable to perform the recall procedure to your vehicle within 60 days after you first brought your vehicle to your Suzuki dealer after April 6, 2007 you may submit a complaint to the Administrator, National Highway Traffic Safety Administration, 400 Seventh Street, S.W., Washington, D.C. 20590 or call the toll free Vehicle Safety Hotline at 1-888-327-4236 (TTY: 1-800-424-9153); or go to <http://www.safercar.gov>.

### Locating an alternate dealer

Suzuki dealers can be located on the internet at [www.suzukicycles.com](http://www.suzukicycles.com) or by calling 1 (800) 828-7433.

### Customer Reimbursement

If your motorcycle is included in the recall and you have paid for the repair or replacement of the fuel delivery pipe assembly, you may be eligible for full or partial reimbursement. Please note the following for which Suzuki may exclude reimbursement:

- Only repairs that are the subject of the safety recall are reimbursable. Additional expenses such as towing, rental, accommodations, damage repairs, etc. will not be reimbursed.
- Reimbursement may be limited to suggested list price on parts and the Suzuki published flat rate time allowance.
- An owner will not be eligible for reimbursement if the expenses for repairs are incurred more than 10 days after the date of the last owner notification letter sent by Suzuki.
- Reimbursement claims may also be excluded when you do not submit adequate documentation. Your authorized Suzuki dealer will request an original or copy of your receipt for the recall repair or replacement, and your owner notification letter.

To obtain information or request reimbursement, contact your Suzuki dealer or the American Suzuki Motor Corporation Motorcycle Customer Service Department, PO Box 1100, Brea, CA 92822-1100, or call (714) 572-1490. You will need to have your Vehicle Identification Number ready when calling.

We thank you for your prompt attention to completing this recall service on your Suzuki motorcycle. We apologize for any inconvenience this campaign causes you. Your safety, satisfaction, and riding enjoyment are priorities for Suzuki.

Sincerely,

American Suzuki Motor Corporation